

More books at [www.FlyingPublisher.com](http://www.FlyingPublisher.com)



# Hepatology

*A Clinical Textbook*

Mauss, Berg, Rockstroh,  
Sarrazin, Wedemeyer

edition 2012



FLYING PUBLISHER

Mauss – Berg – Rockstroh – Sarrazin – Wedemeyer  
Hepatology 2012  
Third Edition

This textbook was supported by a grant from  
Roche Pharma, Germany

# Hepatology 2012

A Clinical Textbook

Editors

Stefan Mauss

Thomas Berg

Juergen Rockstroh

Christoph Sarrazin

Heiner Wedemeyer

Flying Publisher

English language and style:

**Rob Camp**

camporama@gmail.com

## Disclaimer

Hepatology is an ever-changing field. The editors and authors of *Hepatology – A Clinical Textbook* have made every effort to provide information that is accurate and complete as of the date of publication. However, in view of the rapid changes occurring in medical science, as well as the possibility of human error, this site may contain technical inaccuracies, typographical or other errors. Readers are advised to check the product information currently provided by the manufacturer of each drug to be administered to verify the recommended dose, the method and duration of administration, and contraindications. It is the responsibility of the treating physician who relies on experience and knowledge about the patient to determine dosages and the best treatment for the patient. The information contained herein is provided "as is" and without warranty of any kind. The editors and Flying Publisher & Kamps disclaim responsibility for any errors or omissions or for results obtained from the use of information contained herein.

© 2012 by Mauss et al.

Design: Attilio Baghino, [www.baghino.com](http://www.baghino.com)

ISBN: 978-3-924774-73-8

Printed in Germany by Druckhaus Süd, [www.druckhaus-sued.de](http://www.druckhaus-sued.de)

## Foreword

### 3<sup>rd</sup> Edition – 2012

We are pleased to present you with the 3rd Edition of *Hepatology – A Clinical Textbook*. We especially want to offer our thanks to all the authors who have worked so hard to keep their chapters fresh and up-to-date. We have included very exciting updates, especially regarding the new oral treatments for HCV. We also are expanding our project to try to reach a broader range of readers and look forward to collaborating with you to connect with newer specialists as well as those not necessarily in large urban centers or those who have less access to information on the latest diagnostics and treatments.

We would be especially interested in hearing from you regarding your experience with the book, and how it could be made better for you. Please let us know at [www.hepatologytextbook.com](http://www.hepatologytextbook.com) where you can also download this book by chapter, by section or the full book, 100% free. We hope you can give us a few minutes of your time to help us make the next edition better for you and that this project can continue to be a lasting success.

The Editors

Stefan Mauss, Thomas Berg, Jürgen Rockstroh, Christoph Sarrazin, Heiner Wedemeyer

## Foreword

### 2<sup>nd</sup> Edition – 2010

Because hepatology is such a dynamic and exciting area of medicine, regular updates are mandatory in keeping a clinical textbook useful. We are delighted to present this second edition of *Hepatology – A Clinical Textbook*. The first edition was a major success, with more than 80,000 downloads worldwide. In addition, a Romanian translation was carried out by Camelia Sultana and Simona Ruta shortly after the appearance of the first edition. We invite qualified people everywhere to do the same, into any appropriate language! This web-based free-of-charge concept made possible by unrestricted grants from Roche and Gilead has allowed the material to reach countries usually not easily covered by print media, a special quality of this project. We hope this second edition of **Hepatology – A Clinical Textbook** will continue to be a valuable source of information for our readers.

The Editors

Stefan Mauss, Thomas Berg, Jürgen Rockstroh, Christoph Sarrazin, Heiner Wedemeyer

## **Preface**

Hepatology is a rapidly evolving field that will continue to grow and maintain excitement over the next few decades. Viral hepatitis is not unlike HIV 10 or 15 years ago. Today, hepatitis B viral replication can be suppressed by potent antiviral drugs, although there are risks regarding the emergence of resistance. Strategies to enhance the eradication rates of HBV infection still need to be developed. On the other hand, hepatitis C virus infection can be eradicated by treatment with pegylated interferon plus ribavirin, although the sustained virologic response rates are still suboptimal, particularly in those infected by genotype 1. Many new antiviral drugs, especially protease and polymerase inhibitors, are currently in preclinical and clinical development, and the first data from larger clinical trials provide some optimism that the cure rates for patients with chronic hepatitis C will be enhanced with these new agents. In other areas of hepatology, e.g., hereditary and metabolic liver diseases, our knowledge is rapidly increasing and new therapeutic options are on the horizon.

In rapidly evolving areas such as hepatology, is the book format the right medium to gather and summarise the current knowledge? Are these books not likely to be outdated the very day they are published? This is indeed a challenge that can be convincingly overcome only by rapid internet-based publishing with regular updates. Another unmatched advantage of a web-based book is the free and unrestricted global access. Viral hepatitis and other liver diseases are a global burden and timely information is important for physicians, scientists, patients and health care officials all around the world.

The editors of this web-based book – Thomas Berg, Stefan Mauss, Jürgen Rockstroh, Christoph Sarrazin and Heiner Wedemeyer – are young, bright, and internationally renowned hepatologists who have created an excellent state-of-the-art textbook on clinical hepatology. The book is well-written and provides in-depth information without being lengthy or redundant. I am convinced that all five experts will remain very active in the field and will continue to update this book regularly as the science progresses. This e-book should rapidly become an international standard.

**Stefan Zeuzem** – Frankfurt, January 2009

## **Preface**

Therapeutic options and diagnostic procedures in hepatology have quickly advanced during the last decade. In particular, the management of viral hepatitis has completely changed since the early nineties. Before nucleoside and nucleotide analogs were licensed to treat hepatitis B and before interferon  $\alpha$  + ribavirin combination therapy were approved for the treatment of chronic hepatitis C, very few patients infected with HBV or HCV were treated successfully. The only option for most patients with end-stage liver disease or hepatocellular carcinoma was liver transplantation. And even if the patients were lucky enough to be successfully transplanted, reinfection of the transplanted organs remained major challenges. In the late eighties and early nineties discussions were held about rejecting patients with chronic hepatitis from the waiting list as post-transplant outcome was poor.

Today, just 15 years later, hepatitis B represents one of the best indications for liver transplantations, as basically all reinfection can be prevented. In addition, the proportion of patients who need to be transplanted is declining – almost all HBV-infected patients can nowadays be treated successfully with complete suppression of HBV replication and some well-selected patients may even be able to clear HBsAg, the ultimate endpoint of any hepatitis B treatment.

Hepatitis C has also become a curable disease with a sustained response of 50-80% using pegylated interferons in combination with ribavirin. HCV treatment using direct HCV enzyme inhibitors has started to bear fruit (we draw your attention to the HCV Chapters).

Major achievements for the patients do sometimes lead to significant challenges for the treating physician. Is the diagnostic work-up complete? Did I any recent development to evaluate the stage and grade of liver disease? What sensitivity is really necessary for assays to detect hepatitis viruses? When do I need to determine HBV polymerase variants, before and during treatment of hepatitis B? When can I safely stop treatment without risking a relapse? How to treat acute hepatitis B and C? When does a health care worker need a booster vaccination for hepatitis A and B? These are just some of many questions we have to ask ourselves frequently during our daily routine practice. With the increasing number of publications, guidelines and expert opinions it is getting more and more difficult to stay up-to-date and to make the best choices for the patients. That is why *HEPATOLOGY 2012 – A Clinical Textbook* is a very useful new tool that gives a state-of-the art update on many aspects of HAV, HBV, HCV, HDV and HEV infections. The editors are internationally-known experts in the field of viral hepatitis; all have made significant contributions to understanding the pathogenesis of virus-induced liver disease, diagnosis and treatment of hepatitis virus infections.

*HEPATOLOGY 2012 – A Clinical Textbook* gives a comprehensive overview on the epidemiology, virology, and natural history of all hepatitis viruses including hepatitis A, D and E. Subsequent chapters cover all major aspects of the management of hepatitis B and C including coinfections with HIV and liver transplantation. Importantly, complications of chronic liver disease such as hepatocellular carcinoma and recent developments in assessing the stage of liver disease are also covered. Finally, interesting chapters on autoimmune and metabolic non-viral liver diseases complete the book.

We are convinced that this new up-to-date book covering all clinically relevant aspects of viral hepatitis will be of use for every reader. The editors and authors must be congratulated for their efforts.

**Michael P. Manns** – Hannover, January 2009





## Contributing Authors

### **Fernando Agüero**

Preventive Medicine and Public Health  
Parc de Salut Mar  
Pompeu Fabra University  
Public Health Agency of Barcelona  
Barcelona, Spain

### **Hikmet Akkiz**

Department of Gastroenterology and Hepatology  
Çukurova University, School of Medicine  
Adana, Turkey

### **Akif Altnibas**

Yıldırım Beyazıt Education and Research Hospital  
Gastroenterology Clinic  
Ankara, Turkey

### **Matthias J. Bahr**

Dept. of Medicine I  
Sana Kliniken Lübeck  
Kronsforder Allee 71-73  
23560 Lübeck, Germany

### **Lars P. Bechmann**

Department of Gastroenterology and Hepatology,  
University Hospital Essen  
Hufelandstr. 55  
45122 Essen  
Germany

### **Susanne Beckebaum**

Department of Transplant Medicine  
University Hospital Münster  
Domagkstr. 3A  
48149 Münster

### **Thomas Berg**

Sektion Hepatologie  
Klinik und Poliklinik für  
Gastroenterologie & Rheumatologie  
Universitätsklinikum Leipzig  
Liebigstr. 20  
04103 Leipzig, Germany  
thomas.berg@medizin.uni-leipzig.de

Leber- und Studienzentrum am  
Checkpoint  
Charlottenstrasse 81  
10969 Berlin  
berg@leberzentrum-checkpoint.de

### **Albrecht Böhlig**

Sektion Hepatologie  
Klinik und Poliklinik für  
Gastroenterologie & Rheumatologie  
Universitätsklinikum Leipzig  
Liebigstr. 20  
04103 Leipzig, Germany

### **Florian van Bömmel**

Sektion Hepatologie  
Klinik und Poliklinik für  
Gastroenterologie & Rheumatologie  
Universitätsklinikum Leipzig  
Liebigstr. 20  
04103 Leipzig, Germany

### **Christoph Boesecke**

Department of Medicine I  
University Hospital Bonn  
Sigmund-Freud-Strasse 25  
53105 Bonn, Germany

### **Ali Canbay**

Department of Gastroenterology and Hepatology,  
University Hospital Essen  
Hufelandstr. 55  
45122 Essen  
Germany

**Carlos Cervera**

Infectious Diseases Service  
Hospital Clínic – IDIBAPS  
University of Barcelona  
Villarroel, 170  
08036 Barcelona, Spain

**Vito R. Cicinnati**

Department of Transplant Medicine  
University Hospital Münster  
Domagkstr. 3A  
48149 Münster

**Markus Cornberg**

Dept. of Gastroenterology,  
Hepatology and Endocrinology  
Medical School of Hannover  
Carl-Neuberg-Str. 1  
30625 Hannover, Germany

**Maura Dandri**

University Hospital Hamburg-  
Eppendorf  
Zentrum für Innere Medizin  
I. Medizinische Klinik  
Labor Hepatologie und Virus  
Hepatitis  
Martinistr. 52  
20246 Hamburg, Germany

**Neus Freixa**

Psychiatry Department  
Hospital Clínic – IDIBAPS  
University of Barcelona  
Villarroel, 170  
08036 Barcelona, Spain

**Juan-Carlos García-Valdecasas**

Liver Transplant Unit, Department of  
Surgery  
Hospital Clínic – IDIBAPS  
University of Barcelona  
Villarroel, 170  
08036 Barcelona, Spain

**Guido Gerken**

Department of Gastroenterology,  
University Hospital Essen  
Hufelandstr. 55  
45122 Essen, Germany

**Frank Grünhage**

Medical Department II  
Saarland University Hospital  
Kirrbergerstr. 1  
66421 Homburg, Germany

**Svenja Hardtke**

Dept. of Gastroenterology,  
Hepatology and Endocrinology  
Medical School of Hannover  
Carl-Neuberg-Str. 1  
30625 Hannover, Germany

**Bernd Kupfer**

Department of Medicine I  
University Hospital Bonn  
Sigmund-Freud-Strasse 25  
53105 Bonn, Germany

**Montserrat Laguno**

Infectious Diseases Service  
Hospital Clínic – IDIBAPS  
University of Barcelona  
Villarroel, 170  
08036 Barcelona, Spain

**Frank Lammert**

Medical Department II  
Saarland University Hospital  
Kirrbergerstr. 1  
66421 Homburg, Germany

**Christian Lange**

J. W. Goethe-University Hospital  
Medizinische Klinik I  
Theodor-Stern-Kai 7  
60590 Frankfurt am Main, Germany

**Michael P. Manns**

Dept. of Gastroenterology,  
Hepatology and Endocrinology  
Medical School of Hannover  
Carl-Neuberg-Str. 1  
30625 Hannover, Germany

**Christian Manzardo**

Infectious Diseases Service  
Hospital Clínic – IDIBAPS  
University of Barcelona  
Villarroel, 170  
08036 Barcelona, Spain

**Stefan Mauss**

Center for HIV and  
Hepatogastroenterology  
Grafenberger Allee 128a  
40237 Duesseldorf, Germany  
stefan.mauss@center-duesseldorf.de

**José M. Miró**

Infectious Diseases Service  
Hospital Clínic – IDIBAPS  
University of Barcelona  
Villarroel, 170  
08036 Barcelona, Spain

**Asuncion Moreno**

Infectious Diseases Service  
Hospital Clínic – IDIBAPS  
University of Barcelona  
Villarroel, 170  
08036 Barcelona, Spain

**Claus Niederau**

Katholische Kliniken Oberhausen  
gGmbH, St. Josef Hospital  
Department of Internal Medicine  
Academic Teaching Hospital of the  
University  
Duisburg-Essen  
Mülheimer Str. 83  
46045 Oberhausen, Germany

**Jörg Petersen**

Liver Unit IFI Institute for  
Interdisciplinary Medicine  
Asklepios Klinik St George Hamburg  
Lohmühlenstr. 5  
University of Hamburg  
20099 Hamburg, Germany

**Sven Pischke**

Dept. of Gastroenterology,  
Hepatology and Endocrinology  
Medical School of Hannover  
Carl-Neuberg-Str. 1  
30625 Hannover, Germany

**Kerstin Port**

Dept. of Gastroenterology,  
Hepatology and Endocrinology  
Medical School of Hannover  
Carl-Neuberg-Str. 1  
30625 Hannover, Germany

**Karl-Philipp Puchner**

Charité, Campus Virchow-Klinikum,  
Universitätsmedizin  
Medizinische Klinik m. S.  
Hepatologie und Gastroenterologie  
Augustenburger Platz 1  
13353 Berlin, Germany

**Antonio Rimola**

Liver Transplant Unit - CIBEREHD  
Hospital Clínic – IDIBAPS  
University of Barcelona  
Villarroel, 170  
08036 Barcelona, Spain

**J. K. Rockstroh**

Department of Medicine I  
University Hospital Bonn  
Sigmund-Freud-Strasse 25  
53105 Bonn, Germany  
rockstroh@uni-bonn.de

**Christoph Sarrazin**

J. W. Goethe-University Hospital  
Medizinische Klinik 1  
Theodor-Stern-Kai 7  
60590 Frankfurt am Main, Germany  
sarrazin@em.uni-frankfurt.de

**Martin Schäfer**

Department of Psychiatry  
and Psychotherapy  
Kliniken Essen-Mitte  
Ev. Huysenstift  
Henricistraße 92  
45136 Essen, Germany

**Carolynne Schwarze-Zander**

Department of Medicine I  
University Hospital Bonn  
Sigmund-Freud-Strasse 25  
53105 Bonn, Germany

**Ulrich Spengler**

Department of Internal Medicine 1  
University Hospitals of Bonn  
University  
Sigmund-Freud-Strasse 25  
53105 Bonn, Germany

**Christian P. Strassburg**

Dept. of Gastroenterology,  
Hepatology and Endocrinology  
Medical School of Hannover  
Carl-Neuberg-Str. 1  
30625 Hannover, Germany

**Montserrat Tuset**

Pharmacy Department  
Hospital Clínic – IDIBAPS  
University of Barcelona  
Villarroel, 170  
08036 Barcelona, Spain

**Jan-Christian Wasmuth**

Department of Medicine I  
University Hospital Bonn  
Sigmund-Freud-Strasse 25  
53105 Bonn, Germany

**Heiner Wedemeyer**

Dept. of Gastroenterology,  
Hepatology and Endocrinology  
Medical School of Hannover  
Carl-Neuberg-Str. 1  
30625 Hannover, Germany  
wedemeyer.heiner@mh-hannover.de

**Johannes Wiegand**

Sektion Hepatologie  
Klinik und Poliklinik für  
Gastroenterologie & Rheumatologie  
Universitätsklinikum Leipzig  
Liebigstr. 20  
04103 Leipzig, Germany

**Stefan Zeuzem**

J. W. Goethe-University Hospital  
Medizinische Klinik 1  
Theodor-Stern-Kai 7  
60590 Frankfurt am Main, Germany

## Table of Contents

<b>1. Hepatitis A</b>	<b>27</b>
<i>Sven Pischke and Heiner Wedemeyer</i>	27
The virus	27
Epidemiology	27
Transmission	27
Clinical course	28
Extrahepatic manifestations	29
Diagnosis	29
Treatment and prognosis	30
References	30
<b>2. Hepatitis B</b>	<b>32</b>
<i>Christoph Boesecke and Jan-Christian Wasmuth</i>	32
Introduction	32
Transmission	33
Sexual transmission	33
Percutaneous inoculation	33
Perinatal transmission	34
Horizontal transmission	34
Blood transfusion	34
Nosocomial infection	35
Organ transplantation	36
Postexposure prophylaxis	36
Natural history and clinical manifestations	36
Acute hepatitis	36
Chronic hepatitis	37
Prognosis and survival	39
Extrahepatic manifestations	41
References	41
<b>3. Hepatitis C</b>	<b>44</b>
<i>Christoph Boesecke and Jan-Christian Wasmuth</i>	44
Epidemiology	44
Transmission	45
Injection drug use	45
Blood transfusion	45
Organ transplantation	46
Sexual or household contact	46
Perinatal transmission	46
Hemodialysis	47
Other rare transmission routes	47
Needlestick injury	47
Clinical manifestations	47
Acute hepatitis	47
Chronic hepatitis C	48
Extrahepatic manifestations	49
Natural history	49

## 14 Hepatology 2012

Cirrhosis and hepatic decompensation	49
Disease progression	50
References	52
<b>4. Hepatitis E: an underestimated problem?</b>	<b>55</b>
<i>Sven Pischke and Heiner Wedemeyer</i>	55
Introduction	55
HEV: genetic characteristics of the virus	55
Diagnosis of hepatitis E	56
Worldwide distribution of HEV infections	57
Transmission of HEV	58
Acute hepatitis E in immunocompetent individuals	59
Acute and chronic HEV infections in organ transplant recipients	60
Hepatitis E in patients with HIV infection	60
Extrahepatic manifestations of hepatitis E	61
Treatment of chronic hepatitis E	61
Vaccination	61
Conclusions/Recommendations	62
References	62
<b>5. HBV Virology</b>	<b>65</b>
<i>Maura Dandri, Jörg Petersen</i>	65
Introduction	65
Taxonomic classification and genotypes	66
HBV structure and genomic organization	66
HBV structural and non-structural proteins	68
The HBV replication cycle	71
Animal models of HBV infection	75
References	78
<b>6. HCV Virology</b>	<b>85</b>
<i>Bernd Kupfer</i>	85
History	85
Taxonomy and genotypes	86
Viral structure	86
Genome organization	87
Genes and proteins	89
Viral lifecycle	93
Adsorption and viral entry	93
Translation and posttranslational processes	95
HCV RNA replication	96
Assembly and release	96
Model systems for HCV research	97
References	99

<b>7. Prophylaxis and Vaccination</b>	<b>108</b>
<i>Heiner Wedemeyer</i>	108
Introduction	108
Prophylaxis of hepatitis viruses	108
Hepatitis A and E	108
Hepatitis B and D	109
Hepatitis C	109
Vaccination against hepatitis A	110
Vaccination against hepatitis B	111
Efficacy of vaccination against hepatitis B	112
Post-exposure prophylaxis	113
Safety of HBV vaccines	113
Long-term immunogenicity of hepatitis B vaccination	113
Prevention of vertical HBV transmission	114
Vaccination against hepatitis C	114
Vaccination against hepatitis E	115
References	115
<b>8. Hepatitis B: Diagnostic Tests</b>	<b>119</b>
<i>Jörg Petersen</i>	119
Introduction	119
Serological tests for HBV	119
Collection and transport	119
Hepatitis B surface antigen and antibody	120
Hepatitis B core antigen and antibody	120
Hepatitis B e antigen and antibody	121
Serum HBV DNA assays	121
HBV genotypes	122
Antiviral resistance testing	122
Assessment of liver disease	123
Acute HBV infection	123
Past HBV infection	123
Chronic HBV infection	124
Serum transaminases	124
Occult HBV infection	125
Assessment of HBV immunity	125
Liver biopsy and noninvasive liver transient elastography	125
References	126
<b>9. Hepatitis B Treatment</b>	<b>128</b>
<i>Florian van Bömmel, Johannes Wiegand, Thomas Berg</i>	128
Introduction	128
Indication for antiviral therapy	128
Acute hepatitis B	128
Chronic hepatitis B	129
Summary of treatment indications in the German Guidelines of 2011	132
Endpoints of antiviral treatment	132
How to treat	136

## 16 Hepatology 2012

Treatment options	136
Interferons	139
Nucleoside and nucleotide analogs	141
Choosing the right treatment option	146
Prognostic factors for treatment response	147
Monitoring before and during antiviral therapy	151
Treatment duration and stopping rules	152
References	154
<b>10. Management of Resistance in HBV Therapy</b>	<b>160</b>
<i>Stefan Mauss and Heiner Wedemeyer</i>	160
Introduction	160
Antiviral HBV therapy – how to avoid resistance	161
Treatment endpoints	162
Resistance patterns of HBV polymerase inhibitors	163
Combination therapy of chronic hepatitis B to delay development of resistance	166
Management of drug resistance	166
Special considerations in HIV/HBV coinfection	168
Immune escape and polymerase inhibitor resistance	168
Conclusion	169
References	169
<b>11. Hepatitis D – Diagnosis and Treatment</b>	<b>174</b>
<i>Heiner Wedemeyer</i>	174
Introduction	174
Virology of hepatitis delta	175
Epidemiology of hepatitis delta	176
Pathogenesis of HDV infection	178
Clinical course of delta hepatitis	179
Acute HBV/HDV coinfection	179
Chronic delta hepatitis	179
Diagnosis of delta hepatitis	180
Treatment of delta hepatitis	181
Nucleoside and nucleotide analogs	181
Recombinant interferon $\alpha$	182
Pegylated interferon $\alpha$	182
Liver transplantation for hepatitis delta	183
References	184
<b>12. Hepatitis C: Diagnostic Tests</b>	<b>189</b>
<i>Christian Lange and Christoph Sarrazin</i>	189
Serologic assays	190
HCV core antigen assays	191
Nucleic acid testing for HCV	191
Qualitative assays for HCV RNA detection	192
Qualitative RT-PCR	192
Transcription-mediated amplification (TMA) of HCV RNA	192



Quantitative HCV RNA detection	193
Competitive PCR: Cobas® Amplicor HCV 2.0 monitor	193
Branched DNA hybridisation assay (Versant® HCV RNA 3.0 quantitative assay)	194
Real-time PCR-based HCV RNA detection assays	194
Cobas® TaqMan® HCV test	195
RealTime HCV test	196
HCV genotyping	196
Reverse hybridising assay (Versant® HCV Genotype 2.0 System (LiPA))	197
Direct sequence analysis (Trugene® HCV 5'NC genotyping kit)	197
Real-time PCR technology (RealTime™ HCV Genotype II assay)	197
Implications for diagnosing and managing acute and chronic hepatitis C	197
Diagnosing acute hepatitis C	197
Diagnosing chronic hepatitis C	198
Diagnostic tests in the management of hepatitis C therapy	198
References	199
<b>13. Standard Therapy of Chronic Hepatitis C Virus Infection</b>	<b>202</b>
<i>Markus Cornberg, Svenja Hardtke, Kerstin Port, Michael P. Manns, Heiner Wedemeyer</i>	
Goal of antiviral therapy	202
Basic therapeutic concepts and medication	202
Predictors of treatment response	206
Antiviral resistance	206
Treatment of HCV genotype 1	207
Treatment of naïve patients	207
Treatment of patients with prior antiviral treatment failure	212
PEG-IFN maintenance therapy	215
Treatment of HCV genotypes 2 and 3	215
Naïve patients	215
Treatment of HCV G2/3 patients with prior antiviral treatment failure	218
Treatment of HCV genotypes 4, 5, and 6	218
Optimisation of HCV treatment	220
Adherence to therapy	220
Management of side effects and complications	221
Drug interactions	225
Treatment of hepatitis C in special populations	226
Patients with acute hepatitis C	226
Patients with normal aminotransferase levels	227
Patients with compensated liver cirrhosis	228
Patients after liver transplantation	229
Hemodialysis patients	230
Drug abuse and patients on stable maintenance substitution	230
Patients with coinfections	230
Patients with hemophilia	230
Patients with extrahepatic manifestations	230
References	231

<b>14. Hepatitis C: New Drugs</b>	<b>239</b>
<i>Christian Lange, Christoph Sarrazin</i>	239
Introduction	239
HCV life cycle and treatment targets	240
NS3-4A protease inhibitors	241
Molecular biology	241
Ciluprevir (BILN 2061)	243
Telaprevir (Incivek/Incivo®) and boceprevir (Victrelis®)	244
Other NS3 protease inhibitors	245
Resistance to NS3-4A inhibitors	246
NS5B polymerase inhibitors	248
Molecular biology	248
Nucleoside analogs	249
Non-nucleoside analogs	250
NS5A inhibitors	251
Compounds targeting viral attachment and entry	252
Host factors as targets for treatment	252
Cyclophilin B inhibitors	252
Nitazoxanide	253
Silibinin	253
Miravirsen	253
Newer combination therapies	253
Quadruple therapy	254
All-oral therapy without ribavirin	255
All-oral therapy with ribavirin	255
Novel interferons	256
Conclusions	257
References	257
<b>15. Management of Adverse Drug Reactions</b>	<b>262</b>
<i>Martin Schaefer and Stefan Mauss</i>	262
Introduction	262
Flu-like symptoms, fever, arthralgia and myalgia	262
Gastrointestinal disorders	263
Weight loss	263
Asthenia and fatigue	263
Cough and dyspnea	264
Disorders of the thyroid gland	264
Psychiatric adverse events	264
Incidence and profile of psychiatric adverse events	264
Preemptive therapy with antidepressants	266
Sleep disturbances	266
Hematological and immunologic effects	267
Skin disorders and hair loss	267
Adverse events with telaprevir and boceprevir	268
Adherence	269
Conclusion	269
References	269

<b>16. Extrahepatic Manifestations of Chronic HCV</b>	<b>272</b>
<i>Karl-Philipp Puchner, Albrecht Böhlig and Thomas Berg</i>	272
Introduction	272
Mixed cryoglobulinemia	272
Diagnosis	274
Clinical presentation	275
Malignant lymphoproliferative disorders/NHL	276
Etiology and pathogenesis of LPDs in patients with HCV infection	276
Treatment of lymphoproliferative disorders	277
Mixed cryoglobulinemia	277
Systemic vasculitis	278
Peripheral neuropathy	278
Further hematological manifestations	281
HCV-associated thrombocytopenia	281
HCV-related autoimmune hemolytic anemia	281
HCV-related glomerulonephritis	282
Endocrine manifestations	283
Dermatologic and miscellaneous manifestations	284
References	285
<b>17. Management of HBV/HIV coinfection</b>	<b>291</b>
<i>Stefan Mauss and Jürgen Kurt Rockstroh</i>	291
Introduction	291
HBV therapy in HBV/HIV-coinfected patients without HIV therapy	293
Treatment of chronic hepatitis B in HBV/HIV-coinfected patients	296
Management of resistance to HBV polymerase inhibitors	298
Conclusion	298
References	298
<b>18. Management of HCV/HIV Coinfection</b>	<b>302</b>
<i>Christoph Boesecke, Stefan Mauss, Jürgen Kurt Rockstroh</i>	302
Epidemiology of HIV and HCV coinfection	302
Diagnosis of HCV in HIV coinfection	303
Natural course of hepatitis C in HIV coinfection	304
Effect of hepatitis C on HIV infection	305
Effect of HAART on hepatitis C	305
Treatment of hepatitis C in HIV coinfection	306
The choice of antiretrovirals while on HCV therapy	310
Treatment of HCV for relapsers or non-responders	310
Treatment of acute HCV in HIV	311
Liver transplantation in HIV/HCV-coinfected patients	312
Conclusion	313
References	313
<b>19. HBV/HCV Coinfection</b>	<b>318</b>
<i>Carolynne Schwarze-Zander and Jürgen Kurt Rockstroh</i>	318
Epidemiology of HBV/HCV coinfection	318
Screening for HBV/HCV coinfection	318
Viral interactions between HBV and HCV	319

## 20 Hepatology 2012

Clinical scenarios of HBV and HCV infection	319
Acute hepatitis by simultaneous infection of HBV and HCV	319
HCV superinfection	319
HBV superinfection	320
Occult HBV infection in patients with HCV infection	320
Chronic hepatitis in HBV/HCV coinfection	320
Cirrhosis	322
Hepatocellular carcinoma	322
Treatment of HBV and HCV coinfection	322
Conclusion	323
References	323
<b>20. Assessment of Hepatic Fibrosis in Chronic Viral Hepatitis</b>	<b>326</b>
<i>Frank Grünhage and Frank Lammert</i>	326
Introduction	326
Mechanisms of liver fibrosis in chronic viral hepatitis	327
Liver biopsy – the gold standard for staging of liver fibrosis	327
Surrogate markers of liver fibrosis in chronic viral hepatitis	329
Transient elastography	330
Other imaging techniques for the assessment of liver fibrosis	333
Clinical decision algorithms	333
Summary	334
References	334
<b>21. Diagnosis, Prognosis &amp; Therapy of Hepatocellular Carcinoma</b>	<b>338</b>
<i>Ulrich Spengler</i>	338
Classification of HCC	338
Epidemiology	339
Surveillance of patients at high risk and early HCC diagnosis	339
Diagnosis	340
Stage-adapted therapy for liver cancer	341
Potentially curative therapy in BCLC stages 0-A	341
Palliative therapy in BCLC stages B and C	343
Prophylaxis of liver cancer	345
References	346
<b>22. Update in Transplant Hepatology</b>	<b>349</b>
<i>S. Beckebaum, G. Gerken, V. R. Cicinnati</i>	349
Introduction	349
Timing and indications for liver transplantation	349
Patient evaluation	351
Pretransplant management issues	351
Waiting list monitoring of hepatitis B liver transplant candidates	352
Waiting list monitoring and treatment of hepatitis C liver transplant candidates	353
Adjunctive treatment and staging of HCC transplant candidates	353
Living donor liver transplantation: indications, donor evaluation, and outcome	354
Perioperative complications	355

Long-term complications after liver transplantation	356
Opportunistic infections	356
Chronic ductopenic rejection	357
CNI-induced nephrotoxicity and alternative immunosuppressive protocols	358
Other side effects of CNI	359
Corticosteroid minimization/avoidance protocols	359
<i>De novo</i> malignancies	360
Biliary complications	361
Metabolic bone disease	362
Recurrent diseases after liver transplantation	363
Recurrence of hepatitis B in the allograft	363
Recurrence of hepatitis C in the allograft	365
Recurrence of cholestatic liver diseases and autoimmune hepatitis	368
Outcome in patients transplanted for hepatic malignancies	370
Recurrent alcohol abuse after liver transplantation for alcoholic liver disease	371
Experiences with liver transplantation in inherited metabolic liver diseases in adult patients	372
Outcome after liver transplantation for acute hepatic failure	373
Conclusion	373
References	375
<b>23. End-stage Liver Disease, HIV Infection and Liver Transplantation</b>	<b>386</b>
<i>José M. Miró, Fernando Agüero, Montserrat Laguno, Christian Manzardo, Montserrat Tuset, Carlos Cervera, Neus Freixa, Asuncion Moreno, Juan-Carlos García-Valdecasas, Antonio Rimola, and the Hospital Clinic OLT in HIV Working Group</i>	386
Introduction	386
Epidemiology	386
Clinical features of coinfecting patients with ESLD	387
Prognosis after decompensation	388
Management of cirrhosis complications	389
Substance abuse	390
HCV/HBV management	390
Combination antiretroviral therapy (HAART)	391
Orthotopic liver transplant (OLT)	392
Liver disease criteria	392
HIV infection criteria	392
Clinical criteria	392
Immunological criteria	393
Virologic criteria	393
Other criteria	394

## 22 Hepatology 2012

Outcome of OLT in HIV-positive patients	394
HIV/HCV coinfection	395
HIV/HVB coinfection	397
Hepatocellular carcinoma	398
Liver retransplantation	398
Conclusions	399
References	399

## 24. Metabolic Liver Diseases: Hemochromatosis **405**

<i>Claus Niederau</i>	405
Definition and classification of iron overload diseases	405
Type 1 HFE hemochromatosis	406
History	406
Epidemiology	407
Etiology and pathogenesis	407
Diagnosis	409
Early diagnosis and screening	411
Complications of iron overload	415
Therapy	418
Prognosis	418
Juvenile hereditary hemochromatosis	419
Transferrin receptor 2 (TFR2)-related type 3 hemochromatosis	419
Type 4 hemochromatosis – Ferroportin Disease	420
Secondary hemochromatosis	421
Pathophysiology	421
References	422

## 25. NAFLD and NASH **427**

<i>Claus Niederau</i>	427
Introduction	427
Prevalence	427
Demographics and risk factors	428
Pathogenesis	428
Natural history	429
Diagnosis	430
Diet and lifestyle recommendations	431
Pharmacological treatment	432
Surgery for obesity	432
Liver transplantation (LTX) for NASH	433
References	433

## 26. Wilson's Disease **437**

<i>Claus Niederau</i>	437
Introduction	437
Clinical presentation	437

Diagnosis	440
Serum ceruloplasmin	440
Serum copper	441
Urinary copper excretion	442
Hepatic copper concentration	442
Radiolabelled copper	442
Liver biopsy findings	442
Neurology and MRI of the CNS	443
Genetic Studies	443
Treatment	443
Monitoring of treatment	447
References	449
<b>27. Autoimmune Liver Diseases: AIH, PBC and PSC</b>	<b>453</b>
<i>Christian P. Strassburg</i>	453
Autoimmune hepatitis (AIH)	453
Definition and diagnosis of autoimmune hepatitis	453
Epidemiology and clinical presentation	455
Natural history and prognosis	457
Who requires treatment?	457
Who does not require treatment?	458
Standard treatment strategy	458
Treatment of elderly patients	461
Alternative Treatments	462
Budesonide	463
Deflazacort	463
Cyclosporine A	464
Tacrolimus	464
Mycophenolic acid	464
Cyclophosphamide	464
Anti-TNF $\alpha$ antibodies	465
Ursodeoxycholic acid	465
Liver transplantation	466
Recurrence and <i>de novo</i> AIH after liver transplantation	466
Primary biliary cirrhosis	467
Introduction	467
Definition and prevalence of PBC	468
Diagnostic principles of PBC	469
Therapeutic principles in PBC	470
Primary sclerosing cholangitis	473
Diagnosis of primary sclerosing cholangitis (PSC)	473
Differential diagnosis: sclerosing cholangitis	473
Association of PSC with inflammatory bowel disease	475
PSC as a risk factor for cancer	476
Medical therapy of PSC	477
Therapy of IBD in PSC	478
References	479

<b>28. Alcoholic Hepatitis</b>	<b>488</b>
<i>Claus Niederau</i>	488
Health and social problems due to alcohol overconsumption	488
Classification and natural history of alcoholic liver disease	488
Clinical features and diagnosis of alcoholic hepatitis	490
Course and severity	491
Mechanisms of alcohol-related liver injury	492
Treatment	495
Abstinence from alcohol	495
Supportive therapy	495
Corticosteroids	495
Pentoxifylline	496
N-acetyl cysteine	497
Anti-TNF- $\alpha$ therapy	497
Nutritional support	497
Other pharmacologic treatments	498
Liver transplantation	498
Summary	498
References	499
<b>29. Vascular Liver Disease</b>	<b>509</b>
<i>Matthias J. Bahr</i>	509
Disorders of the hepatic sinusoid	509
Sinusoidal obstruction syndrome	509
Peliosis hepatis	513
Disorders of the hepatic artery	514
Hereditary hemorrhagic teleangiectasia (Osler-Weber-Rendu syndrome)	516
Disorders of the portal vein	518
Portal vein thrombosis	518
Nodular regenerative hyperplasia	521
Hepatoportal sclerosis	521
Disorders of the hepatic veins	522
Budd-Chiari syndrome	522
References	524
<b>30. Acute Liver Failure</b>	<b>526</b>
<i>Akif Altinbas, Lars P. Bechmann, Hikmet Akkiz, Guido Gerken, Ali Canbay</i>	526
Introduction and definition	526
Epidemiology and etiologies	526
Intoxication	527
Amanita intoxication	528
Viral hepatitis	529
Immunologic etiologies	529
Wilson's Disease	529
Vascular disorders	529
Pregnancy-induced liver injury	530
Undetermined	530



Molecular mechanisms and clinical presentation	530
Prognosis	532
Treatment	533
General management	533
Hepatic encephalopathy	533
Coagulopathy	534
Liver Transplantation	534
Extracorporeal liver support systems	534
Specific treatment options	535
References	536



# 1. Hepatitis A

*Sven Pischke and Heiner Wedemeyer*

## The virus

Hepatitis A is an inflammatory liver disease caused by infection with the hepatitis A virus (HAV). HAV is a single-stranded 27 nm non-enveloped, icosahedral RNA virus, which was first identified by immune electron microscopy in 1973 (Feinstone 1973). The virus belongs to the hepadnavirus genus of the Picornaviridae.

Seven different HAV genotypes have been described, of which four are able to infect humans (Lemon 1992).

The positive-sense single-stranded HAV RNA has a length of 7.5 kb and consists of a 5' non-coding region of 740 nucleotides, a coding region of 2225 nucleotides and a 3' non-coding region of approximately 60 nucleotides.

## Epidemiology

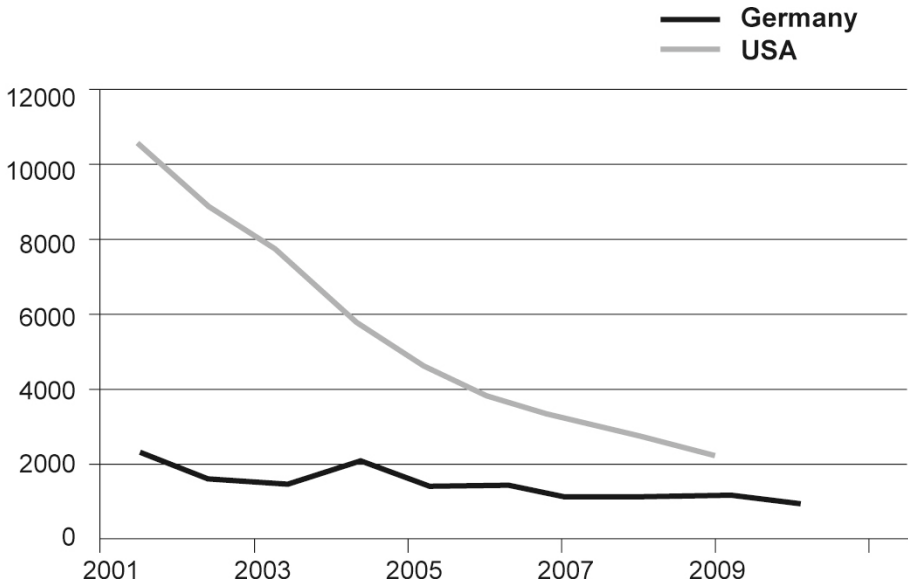
HAV infections occur worldwide, either sporadically or in epidemic outbreaks. An estimated 1.4 million cases of HAV infections occur each year. HAV is usually transmitted and spread via the fecal-oral route (Lemon 1985). Thus, infection with HAV occurs predominantly in areas with lower socio-economic status and reduced hygienic standards, especially in developing, tropical countries. In industrialised countries like the US or Germany the number of reported cases has decreased markedly in the past decades, according to official data published by the Centers for Disease Control and Prevention (CDC, Atlanta, USA) and the Robert Koch Institute (RKI, Berlin, Germany) (Figure 1). This decrease is mainly based on improved sanitary conditions and anti-HAV vaccination. Vaccination programs have also resulted in fewer HAV infections in various endemic countries including Argentina, Brazil, Italy, China, Russia, Ukraine, Spain, Belarus, Israel and Turkey (Hendrickx 2008).

## Transmission

HAV is usually transmitted fecally-orally either by person-to-person contact or ingestion of contaminated food or water. Five days before clinical symptoms appear, the virus can be isolated from feces of patients (Dienstag 1975). The hepatitis A virus usually stays detectable in the feces up to two weeks after the onset

of jaundice. Fecal excretion of HAV up to five months after infection can occur in children and immunocompromised persons.

Risk groups for acquiring an HAV infection in Western countries are health care providers, military personnel, psychiatric patients and men who have sex with men. Parenteral transmission by blood transfusion has been described but is a rare event. Mother-to-fetus transmission has not been reported (Tong 1981).



**Figure 1. Number of reported cases of HAV infections in the USA and Germany within the last decade.** (Sources: CDC and Robert Koch Institut, data for 2010 for the US are not yet available.)

## Clinical course

The clinical course of HAV infection varies greatly, ranging from asymptomatic, subclinical infections to cholestatic hepatitis or fulminant liver failure. Most infections in children are either asymptomatic or unrecognized while 70% of adults develop clinical symptoms of hepatitis with jaundice and hepatomegaly.

The incubation time ranges between 15 to 49 days with a mean of approximately 30 days (Koff 1992). Initial symptoms are usually non-specific and include weakness, nausea, vomiting, anorexia, fever, abdominal discomfort, and right upper quadrant pain (Lednar 1985). As the disease progresses, some patients develop jaundice, darkened urine, uncoloured stool and pruritus. The prodromal symptoms usually diminish when jaundice appears.

Approximately 10% of infections take a biphasic or relapsing course. In these cases the initial episode lasts about 3-5 weeks, followed by a period of biochemical remission with normal liver enzymes for 4-5 weeks. Relapse may mimic the initial episode of the acute hepatitis and complete normalization of ALT and AST values may take several months. (Tong 1995).

Cases of severe fulminant HAV infection leading to hepatic failure occur more often in patients with underlying liver disease. Conflicting data on the course of acute hepatitis A have been reported for patients with chronic hepatitis C. While some studies showed a higher incidence of fulminant hepatitis (Vento 1998), other studies do not confirm these findings and even suggest that HAV superinfection may lead to clearance of HCV infection (Deterding 2006). Other risk factors for more severe courses of acute hepatitis A are age, malnutrition and immunosuppression.

In contrast to hepatitis E, there are no precise data on the outcome of HAV infection during pregnancy. Some data suggest an increased risk of gestational complications and premature birth (Elinav 2006).

HAV infection has a lethal course in 0.1% of children, in 0.4% of persons aged 15-39 years, and in 1.1% in persons older than 40 years (Lemon 1985). In contrast to the other fecally-orally transmitted hepatitis, hepatitis E, no chronic courses of HAV infection have been reported so far.

## Extrahepatic manifestations

Extrahepatic manifestations are uncommon in HAV (Pischke 2007). If they occur, extrahepatic symptoms usually show an acute onset and disappear upon resolution of HAV infection in most cases. Possible extrahepatic manifestations of acute HAV infection are arthralgia, diarrhea, renal failure, red cell aplasia, generalised lymphadenopathy, and pancreatitis. Arthralgia can be found in 11% of patients with hepatitis A.

Very uncommon are severe extrahepatic manifestations like pericarditis and/or renal failure. An association of hepatitis A with cryoglobulinemia has been reported but is a rare event (Schiff 1992). Furthermore, cutaneous vasculitis can occur. In some cases, skin biopsies reveal anti-HAV-specific IgM antibodies and complements in the vessel walls (Schiff 1992). In contrast to hepatitis B or C, renal involvement is rare, and there are very few case reports showing acute renal failure associated with HAV infection (Pischke 2007). Recently it has been shown that approximately 8% of hepatitis A cases are associated with acute kidney injury (Choi 2011).

## Diagnosis

Diagnosis of acute HAV infection is based on the detection of anti-HAV IgM antibodies or HAV RNA. The presence of HAV IgG antibodies can indicate acute or previous HAV infection. HAV IgM and IgG antibodies also become positive early after vaccination, with IgG antibodies persisting for at least two to three decades after vaccination. Available serological tests show a very high sensitivity and specificity.

Delayed seroconversion may occur in immunocompromised individuals, and testing for HAV RNA should be considered in immunosuppressed individuals with unclear hepatitis. HAV RNA testing of blood and stool can determine if the patient is still infectious. However, it has to be kept in mind that various in-house HAV RNA assays may not be specific for all HAV genotypes and thus false-negative results can occur.

Elevated results for serum aminotransferases and serum bilirubin can be found in symptomatic patients (Tong 1995). ALT levels are usually higher than serum aspartate aminotransferase (AST) in non-fulminant cases. Increased serum levels of alkaline phosphatase and gamma-glutamyl transferase indicate a cholestatic form of HAV infection. The increase and the peak of serum aminotransferases usually precede the increase of serum bilirubin. Laboratory markers of inflammation, like an elevated erythrocyte sedimentation rate and increased immunoglobulin levels, can also frequently be detected.

## Treatment and prognosis

There is no specific antiviral therapy for treatment of hepatitis A. The disease usually takes a mild to moderate course, which requires no hospitalisation, and only in fulminant cases is initiation of symptomatic therapy necessary. Prolonged or biphasic courses should be monitored closely. HAV may persist for some time in the liver even when HAV RNA becomes negative in blood and stool (Lanford 2011), which needs to be kept in mind for immunocompromised individuals. Acute hepatitis may rarely proceed to acute liver failure; liver transplantation is required in few cases. In the US, 4% of all liver transplantations performed for acute liver failure were due to hepatitis A (Ostapowicz 2002). In a cohort of acute liver failures at one transplant center in Germany approximately 1% of patients suffered from HAV infection (Hadem 2008). The outcome of patients after liver transplantation for fulminant hepatitis A is excellent. Timely referral to liver transplant centers is therefore recommended for patients with severe or fulminant hepatitis A.

## References

- Choi HK, Song YG, Han SH, et al. Clinical features and outcomes of acute kidney injury among patients with acute hepatitis A. *J Clin Virol* 2011;52:192-7. ([Abstract](#))
- Deterding K, Tegtmeyer B, Cornberg M, et al. Hepatitis A virus infection suppresses hepatitis C virus replication and may lead to clearance of HCV. *J Hepatol* 2006;45:770-8. ([Abstract](#))
- Dienstag JL, Feinstone SM, Kapikian AZ, Purcell RH. Faecal shedding of hepatitis-A antigen. *Lancet* 1975;1:765-7.
- Elinav E, Ben-Dov IZ, Shapira Y, et al. Acute hepatitis A infection in pregnancy is associated with high rates of gestational complications and preterm labor. *Gastroenterology* 2006;130:1129-34. ([Abstract](#))
- Feinstone SM, Kapikian AZ, Purcell RH. Hepatitis A: detection by immune electron microscopy of a viruslike antigen associated with acute illness. *Science* 1973;182:1026-8. ([Abstract](#))
- Hadem J, Stiefel P, Bahr MJ, et al. Prognostic implications of lactate, bilirubin, and etiology in German patients with acute liver failure. *Clin Gastroenterol Hepatol* 2008;6:339-45. ([Abstract](#))
- Hendrickx G, Van Herck K, Vorsters A, et al. Has the time come to control hepatitis A globally? Matching prevention to the changing epidemiology. *J Viral Hepat* 2008;15 Suppl 2:1-15. ([Abstract](#))
- Koff RS. Clinical manifestations and diagnosis of hepatitis A virus infection. *Vaccine* 1992;10 Suppl 1:S15-7. ([Abstract](#))
- Lanford RE, Feng Z, Chavez D, et al. Acute hepatitis A virus infection is associated with a limited type I interferon response and persistence of intrahepatic viral RNA. *Proc Natl Acad Sci U S A* 2011;108:11223-8. ([Abstract](#))
- Lednar WM, Lemon SM, Kirkpatrick JW, Redfield RR, Fields ML, Kelley PW. Frequency of illness associated with epidemic hepatitis A virus infections in adults. *Am J Epidemiol* 1985;122:226-33. ([Abstract](#))

- Lemon SM, Jansen RW, Brown EA. Genetic, antigenic and biological differences between strains of hepatitis A virus. *Vaccine* 1992;10 Suppl 1:S40-4. ([Abstract](#))
- Lemon SM. Type A viral hepatitis. New developments in an old disease. *N Engl J Med* 1985;313:1059-67. ([Abstract](#))
- Ostapowicz G, Fontana RJ, Schiodt FV, et al. Results of a prospective study of acute liver failure at 17 tertiary care centers in the United States. *Ann Intern Med* 2002;137:947-54. ([Abstract](#))
- Pischke S, Vogel, A, Jaeckel, E., Manns, M.P. Immunopathogenesis of Extrahepatic Manifestations in HAV, HBV, and HCV Infections. In: *Liver Immunology*. Totowa, New Jersey: Humana Press, 2007:209-17.
- Schiff ER. Atypical clinical manifestations of hepatitis A. *Vaccine* 1992;10 Suppl 1:S18-20. ([Abstract](#))
- Tong MJ, el-Farra NS, Grew MI. Clinical manifestations of hepatitis A: recent experience in a community teaching hospital. *J Infect Dis* 1995;171 Suppl 1:S15-8. ([Abstract](#))
- Tong MJ, Thursby M, Rakela J, McPeak C, Edwards VM, Mosley JW. Studies on the maternal-infant transmission of the viruses which cause acute hepatitis. *Gastroenterology* 1981;80:999-1004. ([Abstract](#))
- Vento S, Garofano T, Renzini C, et al. Fulminant hepatitis associated with hepatitis A virus superinfection in patients with chronic hepatitis C. *N Engl J Med* 1998;338:286-90. ([Abstract](#))

## 2. Hepatitis B

*Christoph Boesecke and Jan-Christian Wasmuth*

### Introduction

It is estimated that approximately 30% of the world's population has had contact with or are carriers of the hepatitis B virus (HBV). An estimated 350 million of them are HBV carriers (Goldstein 2005). Thus, HBV infection is one of the most important infectious diseases worldwide. Around one million persons die of HBV-related causes annually. There is a wide range of HBV prevalence rates in different parts of the world. HBV prevalence varies from 0.1% up to 20%. Low prevalence areas (0.1-2%) are Western Europe (with wide variation within Europe), United States and Canada, Australia and New Zealand; intermediate prevalence (3-5%) are the Mediterranean countries, Japan, Central Asia, the Middle East, and Latin and South America; and high prevalence areas (10-20%) include southeast Asia, China, and sub-Saharan Africa. This diversity is probably related to differences in age at infection, which correlates with the risk of chronicity. The progression rate from acute to chronic HBV infection decreases with age. It is approximately 90% for an infection acquired perinatally, and is as low as 5% (or even lower) for adults (Stevens 1975, Wasley 2008).

The incidence of new infections has decreased in most developed countries, most likely due to the implementation of vaccination strategies (Rantala 2008). However, exact data is difficult to generate as many cases remain undetected due to the asymptomatic nature of many infections (RKI 2007, CDC 2010). Nevertheless, in Germany 2524 cases of acute hepatitis B were documented in the year 2006, corresponding to an incidence rate of 1.4 per 100,000 inhabitants. In 1997 there were 6135 documented cases of acute hepatitis B. Likewise, the incidence of acute hepatitis B in the United States has decreased by 78% from 1990 to 2005 (Wasley 2008). It is expected that this number will further decrease in countries with implementation of vaccination programs. In Germany 87% of all children starting school were fully vaccinated in 2006 with a trend toward increasing coverage (Poethko-Muller 2007). Interestingly, recent data from a Swiss clinic indicate that uptake in HBV vaccinations is significantly higher when vaccination is endorsed by nurses rather than the patients' physician (Blanco 2011).



Although the incidence of acute HBV infection has decreased in most countries due to the implementation of vaccination programs, HBV-related complications such as cancers and deaths have been on the increase (Gomaa 2008, Hatzakis 2011). Reasons might be the delay of vaccination effects, improved diagnosis, and better documentation of HBV cases. Although a drop in prevalence has been observed in many countries, estimates are difficult due to a continuously growing migration from high or medium prevalence areas to low prevalence areas (Belongia 2008).

## Transmission

The routes of HBV transmission:

- Sexual
- Percutaneous (Intravenous Drug Use)
- Perinatal
- Horizontal
- Transfusion
- Nosocomial infection (including needle-stick injury)
- Organ transplantation

There is considerable variation in the predominance of transmission modes in different geographic areas. For example, in low prevalence areas such as Western Europe, the routes are mainly unprotected sexual intercourse and intravenous drug use. In high prevalence areas like sub-Saharan Africa perinatal infection is the predominant mode of transmission. Horizontal transmission, particularly in early childhood, is regarded as the major route of transmission in intermediate prevalence areas.

### Sexual transmission

In low prevalence areas sexual transmission is the major route of transmission. Approximately 40% of new HBV infections in the United States is considered to be transmitted via heterosexual intercourse, and 25% occurs in men who have sex with men (MSM) (Wasley 2008). Measures to prevent HBV transmission are vaccination and safer sex, i.e., use of condoms. However, there is ongoing debate regarding what to advise low-viremic patients.

### Percutaneous inoculation

Percutaneous transmission seems to be an effective mode of HBV transmission. The most important route is sharing syringes and needles by intravenous drug users. In low prevalence areas such as Europe and the United States about 15% of newly diagnosed HBV infections is in the IVDU population (Wasley 2008). The risk of HBV transmission increases with the number of years of drug use, frequency of injection, and sharing of drug preparation equipment.

Other situations with possible percutaneous inoculation of HBV are sharing shaving razors or toothbrushes, although the exact number remains unknown. In addition, certain practices like acupuncture, tattooing, and body piercing have been associated with transmission of hepatitis B. Public health education and the use of disposable needles or equipment are important methods of prevention.

## Perinatal transmission

Transmission from an HBeAg-positive mother to her infant may occur *in utero*, at the time of birth, or after birth. The rate of infection can be as high as 90%. However, neonatal vaccination is highly efficacious (95%). Its efficacy indicates that most infections occur at or shortly before birth. On the other hand, caesarean section seems not to be as protective as it is in other vertically transmitted diseases like HIV.

The risk of transmission from mother to infant is related to the HBV replicative rate in the mother. There seems to be a direct correlation between maternal HBV DNA levels and the likelihood of transmission. In mothers with highly replicating HBV the risk of transmission may be up to 85 to 90%, and continuously lowers with lower HBV DNA levels (Burk 1994). In some studies there has been almost no perinatal transmission if the mother has no significant ongoing replication ( $<10^5$  log copies/ml) (Li 2004).

It is possible to reduce the risk of perinatal transmission in several ways. The first step is identification of persons at risk. Testing for HBsAg should be performed in all women at the first prenatal visit and repeated later in pregnancy if appropriate (CDC 2011). Newborns born to HBV-positive mothers can be effectively protected by passive-active immunisation ( $>90\%$  protection rate) (del Canho 1997, Dienstag 2008). Hepatitis B immunoglobulin for passive immunization should be given as early as possible (within 12 hours), but can be given up to seven days after birth if seropositivity of the mother is detected later. Active immunisation follows a standard regimen and is given at three time points (10  $\mu\text{g}$  at day 0, month 1, and month 6). Anti-HBV treatment of the mother with nucleoside analogs may be discussed, especially in mothers with high HBV DNA levels, i.e., HBV DNA  $>10^6$  copies/ml or  $2 \times 10^5$  IU/ml. In one randomised, prospective, placebo-controlled study, treatment of the mother with telbivudine resulted in prevention of almost all cases of vertical transmission compared to a vertical transmission rate of about 10% in the arm receiving only active and passive immunisation (Han 2011). Telbivudine or tenofovir seem to be the treatment of choice. Adefovir and entecavir are not recommended in pregnancy (Cornberg 2011).

As mentioned earlier, caesarean section should not be performed routinely, except in cases of high viral load. If the child is vaccinated, (s)he may be breastfed (Hill 2002).

## Horizontal transmission

Children may acquire HBV infection through horizontal transmission via minor breaks in the skin or mucous membranes or close bodily contact with other children. In addition, HBV can survive outside the human body for a prolonged period; as a result, transmission via contaminated household articles such as toothbrushes, razors and even toys may be possible. Although HBV DNA has been detected in various bodily secretions of hepatitis B carriers, there is no firm evidence of HBV transmission via body fluids other than blood.

## Blood transfusion

Blood donors are routinely screened for hepatitis B surface antigen (HBsAg). Therefore incidence of transfusion-related hepatitis B has significantly decreased. The risk of acquiring post-transfusion hepatitis B depends on factors like prevalence

and donor testing strategies. In low prevalence areas it is estimated to be one to four per million blood components transfused (Dodd 2000, Polizzotto 2008). In high prevalence areas it is considerably higher (around 1 in 20,000) (Shang 2007, Vermeulen 2011).

There are different strategies for donor screening. Most countries use HBsAg screening of donors. Others, like the United States, use both HBsAg and anti-HBc. Routine screening of anti-HBc remains controversial, as the specificity is low and patients with cleared hepatitis have to be excluded. Screening of pooled blood samples or even individual samples may be further improved by nucleic acid amplification techniques. However, this is an issue of continuous debate due to relatively low risk reduction and associated costs.

## Nosocomial infection

Nosocomial infection can occur from patient to patient, from patient to health care worker and vice versa. HBV is considered the most commonly transmitted blood-borne virus in the healthcare setting.

In general, nosocomial infection of hepatitis B can and should be prevented. Despite prevention strategies, documented cases of nosocomial infections do occur (Williams 2004). However, the exact risk of nosocomial infection is unknown. The number of infected patients reported in the literature is likely to be an underestimate of true figures as many infected patients may be asymptomatic and only a fraction of exposed patients are recalled for testing.

Strategies to prevent nosocomial transmission of hepatitis B:

- use of disposable needles and equipment,
- sterilization of surgical instruments,
- infection control measures, and
- vaccination of healthcare workers.

Due to the implementation of routine vaccination of health care workers the incidence of HBV infection among them is lower than in the general population (Duseja 2002, Mahoney 1997). Therefore, transmission from healthcare workers to patients is a rare event, while the risk of transmission from an HBV-positive patient to a health care worker seems to be higher.

Healthcare workers positive for hepatitis B are not generally prohibited from working. However, the individual situation has to be evaluated in order to decide on the necessary measures. Traditionally, HBeAg-negative healthcare workers are considered not to be infective, whereas HBeAg-positive healthcare workers should wear double gloves and not perform certain activities, to be defined on an individual basis. However, there have been cases of transmission of hepatitis B from HBsAg-positive, HBeAg-negative surgeons to patients (Teams 1997). Hepatitis B virus has been identified with a precore stop codon mutation resulting in non-expression of HBeAg despite active HBV replication. Therefore, HBV DNA testing has been implemented in some settings, although this may not always be reliable due to fluctuating levels of HBV DNA. In most developed countries guidelines for hepatitis B positive healthcare workers have been established and should be consulted.

## **Organ transplantation**

Transmission of HBV infection has been reported after transplantation of extrahepatic organs from HBsAg positive donors (e.g., kidney, cornea) (Dickson 1997). Therefore, organ donors are routinely screened for HBsAg. The role of anti-HBc is controversial, as it is in screening of blood donors. Reasons are the possibility of false positive results, the potential loss of up to 5% of donors even in low endemic areas, and the uncertainty about the infectivity of organs, especially extrahepatic organs, from donors who have isolated anti-HBc (Dickson 1997). There is an increased risk of HBV infection for the recipient if organs of such donors are transplanted as compared to anti-HBc negative donors.

## **Postexposure prophylaxis**

In case of exposure to HBV in any of the circumstances mentioned above, postexposure prophylaxis is recommended for all non-vaccinated persons. A passive-active immunization is recommended. The first dose of active immunization should be given as early as possible. 12 hours after the exposure is usually considered the latest time point for effective postexposure prophylaxis. One dose of hepatitis B-immunoglobulin (HBIG) should be administered at the same time, if the source is known to be HBsAg-positive. The other two doses of vaccine should be administered according to the usual schedule.

Vaccinated individuals with a documented response do not need postexposure prophylaxis. Individuals who have had no post-vaccination testing should be tested for anti-HBs titer as soon as possible. If this is not possible, or the anti-HBs titer is insufficient (<100 IU/l), they will require a second course of vaccination.

Individuals who are documented non-responders will require two doses of HBIG given one month apart.

## **Natural history and clinical manifestations**

The spectrum of clinical manifestations of HBV infection varies in both acute and chronic disease. During the acute phase, manifestations range from subclinical or anicteric hepatitis to icteric hepatitis and, in some cases, fulminant hepatitis. During the chronic phase, manifestations range from an asymptomatic carrier state to chronic hepatitis, cirrhosis, and hepatocellular carcinoma. Extrahepatic manifestations can occur in both acute and chronic infection.

## **Acute hepatitis**

After HBV transmission, the incubation period lasts from one to four months. A prodromal phase may appear before acute hepatitis develops. During this period a serum sickness-like syndrome may develop. This syndrome manifests with fever, skin rash, arthralgia and arthritis. It will usually cease with the onset of hepatitis. At least 70% of patients will then have subclinical or anicteric hepatitis, while less than 30% will develop icteric hepatitis. The most prominent clinical symptoms of hepatitis are right upper quadrant discomfort, nausea, jaundice and other unspecific constitutional symptoms. In case of coinfection with other hepatitis viruses or other underlying liver disease the clinical course may be more severe. The symptoms including jaundice generally disappear after one to three months, but some patients

have prolonged fatigue even after normalisation of serum aminotransferase concentrations.

Concentrations of alanine and aspartate aminotransferase levels (ALT and AST) may rise to 1000-2000 IU/L in the acute phase. ALT is typically higher than AST. Bilirubin concentration may be normal in a substantial portion of patients. In patients who recover, normalisation of serum aminotransferases usually occurs within one to four months. Persistent elevation of serum ALT for more than six months indicates progression to chronic hepatitis.

The rate of progression from acute to chronic hepatitis B is primarily determined by the age at infection (Ganem 2004, McMahon 1985). In adult-acquired infection the chronicity rate is 5% or less, whereas it is higher if acquired at younger ages. It is estimated to be approximately 90% for perinatally-acquired infection, and 20-50% for infections between the ages of one and five years.

Until recently it was assumed that patients who recover from acute hepatitis B actually clear the virus from the body. However, there is a lot of evidence now suggesting that even in patients positive for anti-HBs and anti-HBc HBV DNA may persist lifelong in the form of covalently closed circular DNA (cccDNA) and this latent infection maintains the T cell response that keeps the virus under control (Yotsuyanagi 1998, Guner 2011). Complete eradication rarely occurs. This is an important finding, as immunosuppression can lead to reactivation of the virus, e.g., after organ transplant or during chemotherapy.

Fulminant hepatic failure is unusual, occurring in approximately 0.1-0.5% of patients. Reasons and risk factors for fulminant hepatitis B are not well understood (Garfein 2004). There may be correlation with substance abuse or coinfections with other viruses. Fulminant hepatitis B is believed to be due to massive immune-mediated lysis of infected hepatocytes. This is why many patients with fulminant hepatitis B have no evidence of HBV replication at presentation.

Antiviral treatment of patients with acute hepatitis B usually is not recommended (Cornberg 2011). In adults, the likelihood of fulminant hepatitis B is less than 1%, and the likelihood of progression to chronic hepatitis B is less than 5%. Therefore, treatment of acute hepatitis B is mainly supportive in the majority of patients. Treatment can be considered in certain subsets of patients, e.g., patients with a severe or prolonged course of hepatitis B, patients coinfecting with other hepatitis viruses or underlying liver diseases, patients with immunosuppression, or patients with fulminant liver failure undergoing liver-transplantation (Kondili 2004, Tillmann 2006). However, early intervention may interfere with the immune response and decrease the likelihood of immune control of HBV infection, thus facilitating chronicity (Tillmann 2006).

In addition, contacts of the patient should be checked for exposure to hepatitis B.

## Chronic hepatitis

The HBV chronicity rate is around 5% or less in adult-acquired infection, as mentioned earlier. In perinatally-acquired infection it is estimated to be approximately 90%, and 20-50% for infections between the age of one and five years (Ganem 2004, McMahon 1985). Most patients will not have a history of acute hepatitis.

Most patients with chronic hepatitis B are clinically asymptomatic. Some may have nonspecific symptoms such as fatigue. In most instances, significant clinical

symptoms will develop only if liver disease progresses to decompensated cirrhosis. In addition, extrahepatic manifestations may cause symptoms.

Accordingly, physical examination will be normal in most instances. In advanced liver disease there may be stigmata of chronic liver disease such as splenomegaly, spider angiomas, caput medusae, palmar erythema, testicular atrophy, gynecomastia, etc. In patients with decompensated cirrhosis, jaundice, ascites, peripheral edema, and encephalopathy may be present.

Laboratory testing shows mild to moderate elevation in serum AST and ALT in most patients, whereas normal transaminases occur rarely. During exacerbation, serum ALT concentration may be as high as 50 times the upper limit of normal. Alfa-fetoprotein concentrations correlate with disease activity. In exacerbations of hepatitis B, concentrations as high as 1000 ng/mL may be seen.

The natural course of chronic HBV infection is determined by the interplay of viral replication and the host immune response. Other factors that may play a role in the progression of HBV-related liver disease include gender, alcohol consumption, and concomitant infection with other hepatitis virus(es). The outcome of chronic HBV infection depends upon the severity of liver disease at the time HBV replication is arrested. Liver fibrosis is potentially reversible once HBV replication is controlled.

There are two different states that are distinguished in chronic HBV infection: first, a high-replicative state with active liver disease and elevated serum ALT. HBV DNA and HBeAg are present. Second, a low or non-replicative phase, where serum ALT may normalize, HBeAg disappears, and anti-HBe antibodies appear. In some patients, viral replication stops completely, as demonstrated by sensitive HBV DNA assays, although they remain HBsAg-positive. These patients have undetectable HBV DNA in serum and normal ALT concentrations. No sign of ongoing liver damage or inflammation is found on liver biopsy. This state is called inactive carrier state.

A small percentage of patients continue to have moderate levels of HBV replication and active liver disease (elevated serum ALT and chronic inflammation on liver biopsies) but remain HBeAg negative. These patients with HBeAg-negative chronic hepatitis may have residual wild type virus or HBV variants that cannot produce HBeAg due to precore or core promoter variants.

The first high-replicative phase may switch into the non-replicative phase either spontaneously or upon antiviral treatment. Conversely, the non-replicative phase may reactivate to the high-replicative phase either spontaneously or with immunosuppression (e.g., in HIV infection or with chemotherapy).

In perinatally-acquired chronic HBV infection there are three different states: An immune tolerance phase, an immune clearance phase, and a late non-replicative phase.

The immune tolerance phase, which usually lasts 10-30 years, is characterized by high levels of HBV replication, as manifested by the presence of HBeAg and high levels of HBV DNA in serum. However, there is no evidence of active liver disease as seen by normal serum ALT concentrations and minimal changes in liver biopsy. It is thought that this lack of liver disease despite high levels of HBV replication is due to immune tolerance to HBV (Dienstag 2008), although the exact mechanisms are unknown. This phenomenon of immune tolerance is believed to be the most important reason for the poor response to interferon therapy in HBeAg-positive

patients with normal ALT levels. During this phase there is a very low rate of spontaneous HBeAg clearance. It is estimated that the rate of spontaneous HBeAg clearance is only 15% after 20 years of infection.

During the second to third decade, the immune-tolerance phase may convert to one of immune clearance. The spontaneous HBeAg clearance rate increases. It is estimated to be 10 to 20% annually. If HBeAg seroconversion occurs, exacerbations of hepatitis with abrupt increases in serum ALT are very often observed. These exacerbations follow an increase in HBV DNA and might be due to a sudden increase in immune-mediated lysis of infected hepatocytes. Most often there are no clinical symptoms during exacerbation, and rise of ALT is only detected by routine examinations. Some patients may develop symptoms mimicking acute hepatitis. Titers of anti-HBc IgM may rise as well as alfa-fetoprotein. If such patients are not known to be HBV-infected, misdiagnosis of acute hepatitis B can be made. HBeAg seroconversion and clearance of HBV DNA from the serum is not always achieved after exacerbation. In these patients recurrent exacerbation with intermittent disappearance of serum HBV DNA with or without HBeAg loss may occur. The non-replicative phase is usually characterized by the absence of HBV DNA and normalisation of serum ALT, like in adult chronic HBV.

Very few patients with chronic HBV infection become HBsAg-negative in the natural course of infection. The annual rate of HBsAg clearance has been estimated to be less than 2% in Western patients and even lower (0.1-0.8%) in patients of Asian origin (Liaw 1991) following an accelerated decrease in HBsAg levels during the 3 years before HBsAg seroclearance (Chen 2011). If loss of HBsAg occurs, prognosis is considered favourable. However, clearance of HBsAg does not exclude development of cirrhosis or hepatocellular carcinoma in some patients, although the exact rate of these complications is not known. This phenomenon is thought to be linked to the fact that HBV DNA may still be present in hepatocytes despite HBsAg loss.

## Prognosis and survival

As clinical course varies among patients, there is a wide variation in clinical outcome and prognosis of chronic HBV infection. The lifetime risk of a liver-related death has been estimated to be 40-50% for men and 15% for women. The risk of progression appears to be higher if immune activation occurs. The estimated five-year rates of progression (Fattovich 2008):

- Chronic hepatitis to cirrhosis – 10-20%
- Compensated cirrhosis to hepatic decompensation – 20-30%
- Compensated cirrhosis to hepatocellular carcinoma – 5-15%

Accordingly, the survival rates are:

- Compensated cirrhosis - 85% at five years
- Decompensated cirrhosis - 55-70% at one year and 15-35% at five years

## Viral replication

In patients with signs of viral replication (i.e., HBeAg-positive) survival is consistently worse than in patients who are HBeAg-negative. However, in recent decades, infections with HBeAg-negative precore mutants prevail by far in newly-acquired infections, resulting in a different pattern of HBeAg-negative and HBV DNA-positive hepatitis with fibrosis progression and HCC in a substantial

proportion of patients. In recent years, the amount of HBV DNA has also been linked to disease progression and has replaced HBeAg-positivity as a marker for disease activity (Chen 2006). This is true both for progression to cirrhosis as well as for the risk of HCC. Therefore, most treatment guidelines today are based on the level of HBV viremia. A reasonable cut-off to distinguish patients with a low risk of progression from patients with a high risk and indication for antiviral treatment is  $10^4$  copies/ml (corresponding to approximately  $2 \times 10^3$  IU/ml) (Cornberg 2011), although other cut-offs may be used.

The duration of viral replication is obviously linked with the risk of development of cirrhosis and HCC. As necroinflammation may persist longer in patients with a prolonged replicative phase, the risk of disease progression is elevated. Conversely, even in patients with decompensated cirrhosis, suppression of HBV replication and delayed HBsAg clearance can result in improvement in liver disease (Fung 2008).

### **Alcohol use**

HBV infection in heavy alcohol users is associated with faster progression to liver injury and an elevated risk of developing cirrhosis and HCC (Bedogni 2008, Marcellin 2008). Survival is reduced compared to HBV-negative heavy alcohol users. However, there is no clear evidence that heavy alcohol use is associated with an enhanced risk of chronic HBV infection, although prevalence of HBV is estimated to be fourfold higher than in controls (Laskus 1992) with variation among regions and cohorts (Rosman 1996).

### **Hepatitis C coinfection**

If coinfection of HCV and HBV occurs, HCV usually predominates. This may lead to lower levels of transaminases and HBV DNA (Jardi 2001). The rate of HBsAg seroconversion even appears to be increased, although this finding may be due to the fact that around one third of patients coinfecting with HBV and HCV lack markers of HBV infection (i.e., HBsAg) although HBV DNA is detectable. Despite lower aminotransferases and HBV DNA levels, liver damage is worse in most instances. The risks of severe hepatitis and fulminant hepatic failure seem to be elevated if both infections occur simultaneously regardless of whether it is an acute coinfection of HBV and HCV or acute hepatitis C in chronic hepatitis B (Liaw 2004).

### **Hepatitis D coinfection**

Acute HBV and HDV coinfection tends to be more severe than acute HBV infection alone. It is more likely to result in fulminant hepatitis. If HDV superinfection in patients with chronic HBV infection occurs, HDV usually predominates, and HBV replication is suppressed (Jardi 2001). Severity of liver disease is worse and progression to cirrhosis is accelerated (Fattovich 2000, Grabowski 2010).

It is very difficult to predict the individual course of hepatitis B due to the many factors influencing disease progression. Several predictive models of disease progression that include clinical parameters (e.g., hepatic decompensation) and laboratory parameters (e.g., bilirubin, INR) have been evaluated, but none of these is used routinely in the clinic at present. In patients with cirrhosis, the MELD-score (Model for End-Stage Liver Disease) and the CHILD-Pugh score are used (see Chapter 3).



## Extrahepatic manifestations

The two major extrahepatic complications of chronic HBV are polyarteritis nodosa and glomerular disease. They occur in 10-20% of patients with chronic hepatitis B and are thought to be mediated by circulating immune complexes (Han 2004).

### Polyarteritis nodosa

The clinical manifestations are similar to those in patients with polyarteritis who are HBV-negative. There may be some clinical benefit to antiviral therapy.

### Nephropathy/Glomerulonephritis

HBV can induce both membranous nephropathy and, less often, membranoproliferative glomerulonephritis. Most cases occur in children. The clinical hallmark is proteinuria. In contrast to polyarteritis nodosa, there is no significant benefit of antiviral treatment.

For further details, please refer to extrahepatic manifestations in Chapter 16.

## References

- Bedogni G, Miglioli L, Masutti F, et al. Natural course of chronic HCV and HBV infection and role of alcohol in the general population: the Dionysos Study. *Am J Gastroenterol* 2008;103:2248-53. ([Abstract](#))
- Belongia EA, Costa J, Gareen IF, et al. NIH Consensus Development Statement on Management of Hepatitis B: Draft. *NIH Consens State Sci Statements* 2008;25:1-29. ([Abstract](#))
- Blanco NB, Probst A, Da Costa VW, et al. Impact of a Nurse Vaccination Program on Hepatitis B Immunity in a Swiss HIV Clinic. *J Acquir Immune Defic Syndr*. 2011;58:472-4. ([Abstract](#))
- Burk RD, Hwang LY, Ho GY, Shafritz DA, Beasley RP. Outcome of perinatal hepatitis B virus exposure is dependent on maternal virus load. *J Infect Dis* 1994;170:1418-23. ([Abstract](#))
- CDC Department of Health & Human Services, Centers for Disease Control and Prevention, Division of Viral Hepatitis. Hepatitis B. General information. *J Pract Nurs* 2010 Summer;60:5-6.
- CDC Centers for Disease Control and Prevention (CDC). Assessing completeness of perinatal hepatitis B virus infection reporting through comparison of immunization program and surveillance data--United States. *MMWR* 2011;60:410-3. ([Abstract](#))
- Chen CJ, Yang HI, Su J, et al. Risk of hepatocellular carcinoma across a biological gradient of serum hepatitis B virus DNA level. *Jama* 2006;295:65-73. ([Abstract](#))
- Chen YC, Jeng WJ, Chu CM, Liaw YF. Decreasing Levels of Hepatitis B Surface Antigen Predict Hepatitis B Surface Antigen Seroclearance in Patients With Inactive Chronic Hepatitis B Virus Infection. *Clin Gastroenterol Hepatol*. 2011 Sep 3. [Epub ahead of print] ([Abstract](#))
- Cornberg M, Protzer U, Petersen J, et al. Prophylaxis, diagnosis and therapy of hepatitis B virus (HBV) infection: the German guidelines for the management of HBV infection. *Z Gastroenterol* 2011;49:871-930.
- Dickson RC, Everhart JE, Lake JR, et al. Transmission of hepatitis B by transplantation of livers from donors positive for antibody to hepatitis B core antigen. The National Institute of Diabetes and Digestive and Kidney Diseases Liver Transplantation Database. *Gastroenterology* 1997;113:1668-74. ([Abstract](#))
- Dienstag JL. Hepatitis B virus infection. *N Engl J Med* 2008;359:1486-500. ([Abstract](#))
- Dodd RY. Current viral risks of blood and blood products. *Ann Med* 2000;32:469-74. ([Abstract](#))
- Duseja A, Arora L, Masih B, et al. Hepatitis B and C virus--prevalence and prevention in health care workers. *Trop Gastroenterol* 2002;23:125-6. ([Abstract](#))
- Fattovich G, Bortolotti F, Donato F. Natural history of chronic hepatitis B: special emphasis on disease progression and prognostic factors. *J Hepatol* 2008;48:335-52. ([Abstract](#))

## 42 Hepatology 2012

- Fung J, Lai CL, Yuen MF. New paradigms for the treatment of chronic hepatitis B. *J Gastroenterol Hepatol* 2008;23:1182-92. (Abstract)
- Ganem D, Prince AM. Hepatitis B virus infection--natural history and clinical consequences. *N Engl J Med* 2004;350:1118-29. (Abstract)
- Garfein RS, Bower WA, Loney CM, et al. Factors associated with fulminant liver failure during an outbreak among injection drug users with acute hepatitis B. *Hepatology* 2004;40:865-73. (Abstract)
- Goldstein ST, Zhou F, Hadler SC, Bell BP, Mast EE, Margolis HS. A mathematical model to estimate global hepatitis B disease burden and vaccination impact. *Int J Epidemiol* 2005;34:1329-39. (Abstract)
- Gomaa AI, Khan SA, Toledano MB, Waked I, Taylor-Robinson SD. Hepatocellular carcinoma: epidemiology, risk factors and pathogenesis. *World J Gastroenterol* 2008;14:4300-8. (Abstract)
- Grabowski J, Wedemeyer H. Hepatitis delta: immunopathogenesis and clinical challenges. *Dig Dis.* 2010;28:133-8. (Abstract)
- Guner R, Karahocagil M, Buyukberber M, et al. Correlation between intrahepatic hepatitis B virus cccDNA levels and other activity markers in patients with HBeAg-negative chronic hepatitis B infection. *Eur J Gastroenterol Hepatol.* 2011;23:1185-91. (Abstract)
- Han SH. Extrahepatic manifestations of chronic hepatitis B. *Clin Liver Dis* 2004;8:403-18. (Abstract)
- Hatzakis A, Wait S, Bruix J, et al. The state of hepatitis B and C in Europe: report from the hepatitis B and C summit conference. *J Viral Hepat.* 2011 Sep;18 Suppl 1:1-16. (Abstract)
- Hill JB, Sheffield JS, Kim MJ, Alexander JM, Sercely B, Wendel GD. Risk of hepatitis B transmission in breast-fed infants of chronic hepatitis B carriers. *Obstet Gynecol* 2002;99:1049-52. (Abstract)
- Jardi R, Rodriguez F, Buti M, et al. Role of hepatitis B, C, and D viruses in dual and triple infection: influence of viral genotypes and hepatitis B precore and basal core promoter mutations on viral replicative interference. *Hepatology* 2001;34:404-10. (Abstract)
- Kondili LA, Osman H, Mutimer D. The use of lamivudine for patients with acute hepatitis B (a series of cases). *J Viral Hepat* 2004;11:427-31. (Abstract)
- Laskus T, Radkowski M, Lupa E, Horban A, Cianciara J, Slusarczyk J. Prevalence of markers of hepatitis viruses in out-patient alcoholics. *J Hepatol* 1992;15:174-78. (Abstract)
- Liaw YF, Sheen IS, Chen TJ, Chu CM, Pao CC. Incidence, determinants and significance of delayed clearance of serum HBsAg in chronic hepatitis B virus infection: a prospective study. *Hepatology* 1991;13:627-31. (Abstract)
- Liaw YF, Chen YC, Sheen IS, Chien RN, Yeh CT, Chu CM. Impact of acute hepatitis C virus superinfection in patients with chronic hepatitis B virus infection. *Gastroenterology* 2004;126:1024-29. (Abstract)
- Li XM, Shi MF, Yang YB, et al. Effect of hepatitis B immunoglobulin on interruption of HBV intrauterine infection. *World J Gastroenterol* 2004;10:3215-17. (Abstract)
- Mahoney FJ, Stewart K, Hu H, Coleman P, Alter MJ. Progress toward the elimination of hepatitis B virus transmission among health care workers in the United States. *Arch Intern Med* 1997;157:2601-5. (Abstract)
- Marcellin P, Pequignot F, Delarocque-Astagneau E, et al. Mortality related to chronic hepatitis B and chronic hepatitis C in France: evidence for the role of HIV coinfection and alcohol consumption. *J Hepatol* 2008;48:200-7. (Abstract)
- McMahon BJ, Alward WL, Hall DB, et al. Acute hepatitis B virus infection: relation of age to the clinical expression of disease and subsequent development of the carrier state. *J Infect Dis* 1985;151:599-603. (Abstract)
- Poethko-Muller C, Kuhnert R, Schlaud M. [Vaccination coverage and predictors for vaccination level. Results of the German Health Interview and Examination Survey for Children and Adolescents (KiGGS)]. *Bundesgesundheitsblatt Gesundheitsforschung Gesundheitsschutz* 2007;50:851-62.
- Polizzotto MN, Wood EM, Ingham H, Keller AJ. Reducing the risk of transfusion-transmissible viral infection through blood donor selection: the Australian experience 2000 through 2006. *Transfusion* 2008;48:55-63. (Abstract)
- Rantala M, van de Laar MJ. Surveillance and epidemiology of hepatitis B and C in Europe - a review. *Euro Surveill* 2008;13:pii18880. (Abstract)

- RKI. Hepatitis C: RKI-Ratgeber Infektionskrankheiten. Epidemiologisches Bulletin 2004;17:141.
- Rosman AS, Waraich A, Galvin K, Casiano J, Paronetto F, Lieber CS. Alcoholism is associated with hepatitis C but not hepatitis B in an urban population. *Am J Gastroenterol* 1996;91:498-505. ([Abstract](#))
- Shang G, Seed CR, Wang F, Nie D, Farrugia A. Residual risk of transfusion-transmitted viral infections in Shenzhen, China, 2001 through 2004. *Transfusion* 2007;47:529-39. ([Abstract](#))
- Stevens CE, Beasley RP, Tsui J, Lee WC. Vertical transmission of hepatitis B antigen in Taiwan. *N Engl J Med* 1975;292:771-4. ([Abstract](#))
- Teams. Transmission of hepatitis B to patients from four infected surgeons without hepatitis B e antigen. The Incident Investigation Teams and others. *N Engl J Med* 1997;336:178-84. ([Abstract](#))
- Tillmann HL, Hadem J, Leifeld L, et al. Safety and efficacy of lamivudine in patients with severe acute or fulminant hepatitis B, a multicenter experience. *J Viral Hepat* 2006;13:256-63. ([Abstract](#))
- Vermeulen M, Dickens C, Lelie N, et al. Hepatitis B virus transmission by blood transfusion during 4 years of individual-donation nucleic acid testing in South Africa: estimated and observed window period risk. *Transfusion*. 2011 Oct 7. doi: 10.1111/j.1537-2995.2011.03355.x. ([Abstract](#))
- Wasley A, Grytdal S, Gallagher K. Surveillance for acute viral hepatitis--United States, 2006. *MMWR Surveill Summ* 2008;57:1-24. ([Abstract](#))
- Williams IT, Perz JF, Bell BP. Viral hepatitis transmission in ambulatory health care settings. *Clin Infect Dis* 2004;38:1592-8. ([Abstract](#))
- Yotsuyanagi H, Yasuda K, Iino S, et al. Persistent viremia after recovery from self-limited acute hepatitis B. *Hepatology* 1998;27:1377-82. ([Abstract](#))

### 3. Hepatitis C

*Christoph Boesecke and Jan-Christian Wasmuth*

#### **Epidemiology**

Hepatitis C is a disease with a significant global impact. According to the World Health Organization there are 130-170 million people infected with the hepatitis C virus (HCV), corresponding to 2-2.5% of the world's total population. There are considerable regional differences. In some countries, e.g., Egypt, the prevalence is as high as 22% (WHO 2011). In Africa and the western Pacific the prevalence is significantly higher than in North America and Europe (RKI 2004).

It is estimated that there are 2-5 million HCV-positive persons in Europe. The prevalence of HCV antibodies in otherwise healthy blood donors is approximately 1.6% in the United States, 1.15% in Italy, 0.4% in Germany, and 0.23% in Scandinavia (RKI 2004, Hatzakis 2011). The number of patients HCV RNA-positive is estimated to be around 80 to 90% of all HCV antibody-positive persons. Certain groups are preferentially affected: The highest risk factor in most cases is injection drug use. But patients undergoing hemodialysis and persons who received blood transfusions before 1991 are at risk also. In Europe and the United States chronic hepatitis C is the most common chronic liver disease and the majority of liver transplants performed are for chronic HCV.

It is difficult to determine the number of new HCV infections, as most acute cases will not be noticed clinically. Fewer than 25% of acute cases of hepatitis C are clinically apparent (Vogel 2009). In addition, the age of infection upon diagnosis is not possible to determine in most cases. Nevertheless, it has to be assumed that the number of new infections has considerably decreased over the past decades. For the United States it is estimated that the number of new cases of acute HCV infection has fallen from approximately 230,000 per year in the 1980s to about 20,000 cases per year currently (Wasley 2008). This decrease is primarily associated with reduced infections in injection drug users, a probable consequence of changes in injection practices motivated by education about human immunodeficiency virus (HIV) transmission. Transfusion-associated hepatitis C has had little impact on this decline, as the number of cases has been reduced almost to zero. The only different trend is an increase in acute hepatitis C infections in HIV-positive men who have sex with men (MSM) globally over the last decade (Boesecke 2011).

## Transmission

Parenteral exposure to the hepatitis C virus is the most efficient means of transmission. The majority of patients infected with HCV in Europe and the United States acquired the disease through intravenous drug use or blood transfusion. The latter has become rare since routine testing of the blood supply for HCV began in the early 1990s. Other types of parenteral exposure are important in specific regions in the world.

The following possible routes of infection have been identified in anti-HCV-positive blood donors (in descending order of transmission risk):

- Injection drug use
- Blood transfusion
- Sex with an intravenous drug user
- Having been in jail more than three days
- Religious scarification
- Having been struck or cut with a bloody object
- Pierced ears or body parts
- Immunoglobulin injection

Very often in patients with newly diagnosed HCV infection no clear risk factor can be identified.

### Injection drug use

Injection drug use has been the most commonly identified source of acute HCV infection. It is estimated that most newly acquired infections occur in individuals who have injected illegal drugs. The seroprevalence of anti-HCV antibodies in groups of intravenous drug users may be up to 70% with considerable variation depending on factors such as region, risk behaviour, socioeconomic status, etc, underscoring the efficiency of transmission via direct blood contact (Sutton 2008). HCV infection also has been associated with a history of intranasal cocaine use, presumably due to blood on shared straws or other sniffing paraphernalia. This may explain partly the recent increase in cases of acute HCV infections in HIV-positive MSM (Schmidt 2011).

### Blood transfusion

In the past, blood transfusion or use of other blood products was a major risk factor for transmission of HCV. In some historic cohorts 10% or more of patients who received blood transfusions were infected with hepatitis C (Alter 1989). However, blood donor screening for HCV since the early 1990s has nearly eliminated this transmission route. Blood donors are screened for anti-HCV antibodies and HCV RNA – at least in developed countries. The risk is now estimated to be between 1:500,000 and 1:1,000,000 units (Pomper 2003).

In cohorts of multiply transfused patients such as hemophiliacs, over 90% of patients were infected with hepatitis C in the past (Francois 1993). Since the use of routine inactivated virus (e.g., heat inactivation or pasteurization) or recombinant clotting factors, new cases of hepatitis C infection have become uncommon in these patients.

## **Organ transplantation**

Transplant recipients who receive organs from HCV-positive donors have a high risk of acquiring HCV infection. Transmission rates in different cohorts vary from 30 to 80% (Pereira 1991, Roth 1994). Therefore, most transplant organisations have developed strategies for screening and selective utilization of organs from anti-HCV positive donors.

## **Sexual or household contact**

Usual household contacts do not pose a risk of HCV transmission.

The efficiency of HCV transmission by sexual contact is very low. However, there is no doubt that sexual transmission of hepatitis C is possible.

The exact risk of HCV transmission in monogamous heterosexual relationships has been difficult to determine. It appears that the risk in long-term partnerships is very low. In prospective cohorts of monogamous, heterosexual couples, there was a long-term transmission risk of 0.01% or lower (Vandelli 2004). Factors that may increase the risk of HCV infection include greater numbers of sex partners, history of sexually transmitted diseases, and not using a condom. Whether underlying HIV infection increases the risk of heterosexual HCV transmission to an uninfected partner is unclear. Very often it is difficult to rule out the possibility that transmission results from risk factors other than sexual exposure.

Outbreaks of cases of acute hepatitis C in several cities in Europe and the United States among men who have sex with men (MSM) have focused attention on sexual transmission of HCV (Boesecke 2011). There is clear evidence unprotected sex can account for the transmission of HCV. Unprotected anal sex, fisting, having many sex partners in a short time period, a concomitant sexually transmitted disease including HIV and use of recreational drugs were identified as risk factors (Danta 2007, Schmidt 2011). It appears that mucosal damage is a prerequisite for HCV transmission. According to these observations, the seroprevalence of HCV in MSM ranges from about 4 to 8%, which is higher than the HCV prevalence reported for general European populations.

Patients with acute or chronic HCV infection should be advised that transmission to sexual contacts is a possibility, although the risk is extremely low in heterosexual relationships. It is likely that the use of condoms will lower the risk of sexual transmission further. However, in most countries there are no firm recommendations to use barrier precautions in stable monogamous sexual partnerships. The transmission risk in MSM is considerably higher so that – in conjunction with the risk of other sexually transmitted diseases – safer sex practices are advised for this group.

## **Perinatal transmission**

The risk of perinatal transmission of HCV in HCV RNA-positive mothers is estimated to be 5% or less (Ohto 1994). In mothers coinfecting with HIV this risk correlates with immunosuppression and has been described in up to 20%. Today, there are no specific recommendations for prevention of perinatal transmission (Pembrey 2005). Cesarean section has not been shown to reduce the transmission risk. There is no evidence that breastfeeding is a risk for infection among infants born to HCV-infected women. Early diagnosis of infection in newborns requires

HCV RNA testing since anti-HCV antibodies are passively transferred from the mother.

## **Hemodialysis**

Patients who participate in chronic hemodialysis programs are at increased risk for hepatitis C. The prevalence of HCV antibodies in such patients reaches 15%, although it has declined in recent years (Fissell 2004). A number of risk factors have been identified for HCV infection among dialysis patients. These include blood transfusions, duration of hemodialysis, prevalence of HCV infection in the dialysis unit, and type of dialysis. The risk is higher with in-hospital hemodialysis as opposed to peritoneal dialysis. The best strategy to prevent hemodialysis-associated HCV transmission is subject to debate.

## **Other rare transmission routes**

Rare sources of percutaneous transmission of HCV are contaminated equipment used during medical procedures, procedures involved in traditional medicine (e.g., scarification, cupping), tattooing, and body piercing (Haley 2001). All these routes bear the potential of transmitting HCV. However, in most instances it is not clear if the risk is due to the procedure itself, or whether there are possible contacts with persons involved who are HCV-positive. In addition, transmission via these routes is so rare that persons with exposure are not at increased risk for acquiring hepatitis C.

## **Needlestick injury**

There is some risk of HCV transmission for health care workers after unintentional needlestick injury or exposure to other sharp objects. The incidence of seroconversion after exposure to an HCV-positive source is generally estimated to be less than 2% (MMWR 2001). However, data are divergent and figures ranging from 0 to 10% can be found (Mitsui 1992). Exposure of HCV to intact skin has not been associated with HCV transmission.

## **Clinical manifestations**

The spectrum of clinical manifestations of HCV infection varies in acute versus chronic disease. Acute infection with HCV is most often asymptomatic (Vogel 2009) and leads to chronic infection in about 80% of cases. The manifestations of chronic HCV range from an asymptomatic state to cirrhosis and hepatocellular carcinoma. HCV infection usually is slowly progressive. Thus, it may not result in clinically apparent liver disease in many patients if the infection is acquired later in life. Approximately 20-30% of chronically infected individuals develop cirrhosis over a 20-30 year period of time.

## **Acute hepatitis**

After inoculation of HCV, there is a variable incubation period. HCV RNA in blood (or liver) can be detected by PCR within several days to eight weeks. Aminotransferases become elevated approximately 6-12 weeks after exposure (range 1-26 weeks). The elevation of aminotransferases varies considerably among individuals, but tends to be more than 10-30 times the upper limit of normal

(typically around 800 U/l). HCV antibodies can be found for the first time around 8 weeks after exposure although in some patients it may take several months before HCV antibodies can be detected by ELISA testing.

However, the majority of newly-infected patients will be asymptomatic and have a clinically non-apparent or mild course. Jaundice as a clinical feature of acute hepatitis C will be present in less than 25% of infected patients. Therefore, acute hepatitis C will not be noticed in most patients (Vogel 2009). Periodic screening for infection may be warranted in certain groups of patients who are at high risk for infection, e.g., homosexually-active patients with HIV infection.

Other symptoms that may occur are similar to those in other forms of acute viral hepatitis, including malaise, nausea, and right upper quadrant pain. In patients who experience such symptoms of acute hepatitis, the illness typically lasts for 2-12 weeks. Along with clinical resolution of symptoms, aminotransferases levels will normalize in about 40% of patients. Loss of HCV RNA, which indicates cure from hepatitis C, occurs in fewer than 20% of patients regardless of normalisation of aminotransferases.

Fulminant hepatic failure due to acute HCV infection is very rare. It may be more common in patients with underlying chronic hepatitis B virus infection (Chu 1999).

## **Chronic hepatitis C**

The risk of chronic HCV infection is high. 80-100% of patients remain HCV RNA positive after acute hepatitis C (Alter 1999, Vogel 2009). Most of these will have persistently elevated liver enzymes in further follow-up. By definition, hepatitis C is regarded to be chronic after persistence of more than six months. Once chronic infection is established, there is a very low rate of spontaneous clearance.

It is unclear why infection with HCV results in chronic infection in most cases. Genetic diversity of the virus and its tendency toward rapid mutation may allow HCV to constantly escape immune recognition. Host factors may also be involved in the ability to spontaneously clear the virus. Factors that have been associated with successful HCV clearance are HCV-specific CD4 T cell responses, high titers of neutralising antibodies against HCV structural proteins, IL28B gene polymorphisms and specific HLA-DRB1 and -DQB1 alleles (Lauer 2001, Thomas 2009, Rauch 2010). Infection with HCV during childhood appears to be associated with a lower risk of chronic infection, approximately 50-60% (Vogt 1999). Finally, there seem to be ethnic differences, with lower risk of chronicity in certain populations.

Most patients with chronic infection are asymptomatic or have only mild nonspecific symptoms as long as cirrhosis is not present (Merican 1993, Lauer 2001). The most frequent complaint is fatigue. Less common manifestations are nausea, weakness, myalgia, arthralgia, and weight loss. HCV infection has also been associated with cognitive impairment. All these symptoms are non-specific and do not reflect disease activity or severity (Merican 1993). Very often symptoms may be caused by underlying diseases (e.g., depression), and it can be difficult to distinguish between different diseases. Fatigue as the most common symptom may be present in many other situations (including healthy control groups within clinical studies). Hepatitis C is rarely incapacitating.

Aminotransferase levels can vary considerably over the natural history of chronic hepatitis C. Most patients have only slight elevations of transaminases. Up to one third of patients have a normal serum ALT (Martinot-Peignoux 2001, Puoti 2002).



About 25% of patients have a serum ALT concentration of more than twice normal, but usually less than 5 times above the upper limit of normal. Elevations of 10 times the upper limit of normal are very seldomly seen.

There is a poor correlation between concentrations of aminotransferases and liver histology. Even patients with normal serum ALT show histologic evidence of chronic inflammation in the majority of cases (Mathurin 1998). The degree of injury is typically minimal or mild in these patients. Accordingly, normalisation of aminotransferases after interferon therapy does not necessarily reflect histologic improvement.

## Extrahepatic manifestations

Around 30 to 40% of patients with chronic hepatitis C have an extrahepatic manifestation of HCV (Zignego 2008). There is a wide variety of extrahepatic manifestations described as being associated with HCV:

- Hematologic manifestations (essential mixed cryoglobulinemia, lymphoma)
- Autoimmune disorders (thyroiditis, presence of various autoantibodies)
- Renal disease (membranoproliferative glomerulonephritis)
- Dermatologic disease (porphyria cutanea tarda, lichen planus)
- Diabetes mellitus

For further details refer to Chapter 16.

## Natural history

The risk of developing cirrhosis within 20 years is estimated to be around 10 to 20%, with some studies showing estimates up to 50% (Poynard 1997, Wiese 2000, Sangiovanni 2006, de Ledinghen 2007). Due to the long course of hepatitis C the exact risk is very difficult to determine, and figures are divergent for different studies and populations. In fact, chronic hepatitis C is not necessarily progressive in all affected patients. In several cohorts it has been shown that a substantial number of patients will not develop cirrhosis over a given time. It is estimated that about 30% of patients will not develop cirrhosis for at least 50 years (Poynard 1997).

Therefore, studies with short observation periods sometimes fail to show an increase in mortality. In addition, survival is generally not impaired until cirrhosis has developed. On the other hand, there is no doubt that patients with chronic hepatitis C have a high risk of cirrhosis, decompensation, and hepatocellular carcinoma in long-term follow-up. For example, in a cohort of patients with post-transfusion hepatitis C evaluated more than 20 years after transfusion 23% had chronic active hepatitis, 51% cirrhosis, and 5% hepatocellular carcinoma (Tong 1995). It is not completely understood why there are such differences in disease progression. An influence of host and viral factors has to be assumed.

## Cirrhosis and hepatic decompensation

Complications of hepatitis C occur almost exclusively in patients who have developed cirrhosis. Interestingly, non-liver related mortality is higher in cirrhotic patients as well. However, cirrhosis may be very difficult to diagnose clinically, as most cirrhotic patients will be asymptomatic as long as hepatic decompensation does not occur. Findings that can be associated with cirrhosis are hepatomegaly

and/or splenomegaly on physical examination, elevated serum bilirubin concentration, hyperalbuminemia, or low platelets. Other clinical findings associated with chronic liver disease may be found such as spider angiomas, caput medusae, palmar erythema, testicular atrophy, or gynaecomastia. Most of these findings are found in less than half of cirrhotic patients, and therefore none is sufficient to establish a diagnosis of cirrhosis.

Hepatic decompensation can occur in several forms. Most common is ascites, followed by variceal bleeding, encephalopathy and jaundice. As mentioned earlier, hepatic decompensation will develop only in cirrhotic patients. However, not all patients with cirrhosis actually show signs of decompensation over time. The risk for decompensation is estimated to be close to 5% per year in cirrhotics (Poynard 1997). Once decompensation has developed the 5-year survival rate is roughly 50% (Planas 2004). For this group of patients liver transplantation is the only effective therapy.

Similar to decompensation, hepatocellular carcinoma (HCC) develops solely in patients with cirrhosis (in contrast to chronic hepatitis B). The risk for HCC has been estimated to be less than 3% per year once cirrhosis has developed (Di Bisceglie 1997, Fattovich 1997). However, HCV-associated HCC has significant impact on survival (see Chapter 21).

Elevated concentrations of  $\alpha$ -fetoprotein (AFP) do not necessarily indicate HCC. AFP may be mildly elevated in chronic HCV infection (i.e., 10 to 100 ng/mL). Levels above 400 ng/mL as well as a continuous rise in AFP over time are suggestive of HCC.

## Disease progression

Chronic hepatitis C has different courses among individuals. It is not completely understood why there are differences in disease progression. Several factors have been identified that may be associated with such differences. However, other factors not yet identified may also be important.

**Age and gender:** Acquisition of HCV infection after the age of 40 to 55 may be associated with a more rapid progression of liver injury, as well as male gender (Svrtlih 2007). On the contrary, children appear to have a relatively low risk of disease progression (Child 1964). In one cohort, for example, only 1 of 37 patients with HCV RNA in serum had elevated levels of serum aminotransferases, and only 3 of 17 (18%) who had liver biopsies approximately 20 years after exposure had histologic signs of progressive liver disease.

**Ethnic background:** Disease progression appears to be slower and changes in liver histology less severe in African-Americans (Sterling 2004).

**HCV-specific cellular immune response:** The severity of liver injury is influenced by the cellular immune response to HCV-specific targets. Inflammatory responses are regulated by complex mechanisms and probably depend on genetic determinants such as HLA expression (Hraber 2007). Whether this determines progression of liver disease is not clear.

**Alcohol intake:** Alcohol increases HCV replication, enhances the progression of chronic HCV, and accelerates liver injury (Gitto 2009). Even moderate amounts of alcohol appear to increase the risk of fibrosis. Accordingly, in alcoholic patients with cirrhosis and liver failure a high prevalence of anti-HCV antibodies has been

described. Alcohol intake should be avoided in all patients with chronic hepatitis C. There is no clear amount of safe alcohol intake.

**Daily use of marijuana:** Daily use of marijuana has been associated with more rapid fibrosis progression, possibly through stimulation of endogenous hepatic cannabinoid receptors.

**Other host factors:** Genetic polymorphisms of certain genes might influence the fibrosis progression rate (Jonsson 2008). For example, transforming growth factor B1 (TGF B1) phenotype or PNPLA3 (adiponutrin) are correlated with fibrosis stage (Zimmer 2011). Patients with moderate to severe steatosis are at higher risk for developing hepatic fibrosis.

**Viral coinfection:** Progression of hepatitis C clearly is accelerated in HIV-infected patients (see section on coinfection). Acute hepatitis B in a patient with chronic hepatitis C may be more severe. Chronic hepatitis B may be associated with decreased HCV replication as opposed to HCV monoinfected patients, although HCV usually predominates. Nevertheless, liver damage is usually worse and progression faster in patients with dual HBV/HCV infections. Around one third of patients coinfecting with HBV and HCV lack markers of HBV infection (i.e., HBsAg) although HBV DNA is detectable.

**Geography and environmental factors:** There are some obvious geographic differences (Lim 2008). For example, hepatocellular carcinoma is observed more often in Japan than in the United States. The reason for this is not clear.

**Use of steroids:** It is well known that use of steroids increases the HCV viral load, while the effect on aminotransferases is variable. They tend to decrease in most patients, although increases in transaminases and bilirubin have also been described. Reducing dosage of corticosteroids returns HCV viral load to baseline. However, the clinical consequences of corticosteroid use are largely unknown. It seems to be reasonable to assume that short-term use of corticosteroids is not associated with significant changes in long-term prognosis.

**Viral factors:** The influence of viral factors on disease progression is unclear. Overall, there seems to be no significant role of different genotypes and quaspecies on fibrosis progression or outcome. However, coinfection with several genotypes may have a worse outcome as compared to mono-infection.

It is very difficult to predict the individual course of hepatitis C due to the many factors influencing disease progression. Today, assessment of liver fibrosis by non-invasive techniques such as transient elastography, AFRI or by liver biopsy is the best predictor of disease progression (Gebo 2002). The grade of inflammation and stage of fibrosis are useful in predicting further clinical course. In patients with severe inflammation or bridging fibrosis virtually all patients will develop cirrhosis within ten years. In contrast, patients with mild inflammation and no fibrosis have an annual progression risk to cirrhosis of around 1%.

Several predictive models of disease progression that include clinical parameters (e.g., hepatic decompensation) and laboratory parameters (e.g., bilirubin, INR) have been evaluated, but none of these models is routinely used in the clinic at present. In patients with cirrhosis, the MELD score (Model for End-Stage Liver Disease) and the Child score (Table 1) are used to stage disease and to describe the prognosis (see Chapters 22 & 23). The MELD Score is used especially to estimate relative disease severity and likely survival of patients awaiting liver transplant. It is calculated as: MELD Score =  $10 \times ((0.957 \times \ln(\text{Creatinine})) + (0.378 \times \ln(\text{Bilirubin})) + (1.12 \times$

$\ln(\text{INR})) + 6.43$ . An online calculator and further information can be found at the website of The United Network for Organ Sharing (UNOS) (<http://www.unos.org>).

**Table 1. Child-Pugh classification of severity of liver disease (Child 1964).\***

	Points assigned		
	1	2	3
Ascites	Absent	Slight	Moderate
Bilirubin, mg/dL	<2	2-3	>3
Albumin, g/dL	>3.5	2.8-3.5	<2.8
Prothrombin time			
Seconds over control	<4	4-6	>6
INR	<1.7	1.7-2.3	>2.3
Encephalopathy	None	Grade 1-2	Grade 3-4

\* A total score of 5-6 is considered stage A (well-compensated disease); 7-9 is stage B (significant functional compromise); and 10-15 is stage C (decompensated disease). These grades correlate with one- and two-year patient survival (stage A: 100 and 85 percent; stage B: 80 and 60 percent; stage C: 45 and 35 percent).

## References

- Alter HJ, Purcell RH, Shih JW, et al. Detection of antibody to hepatitis C virus in prospectively followed transfusion recipients with acute and chronic non-A, non-B hepatitis. *N Engl J Med* 1989;321:1494-500. ([Abstract](#))
- Alter MJ, Kruszon-Moran D, Nainan OV, et al. The prevalence of hepatitis C virus infection in the United States, 1988 through 1994. *N Engl J Med* 1999;341:556-62. ([Abstract](#))
- Boesecke C, Vogel M. HIV and hepatitis C co-infection: acute HCV therapy. *Curr Opin HIV AIDS*. 2011;6:459-64. ([Abstract](#))
- Chu CM, Yeh CT, Liaw YF. Fulminant hepatic failure in acute hepatitis C: increased risk in chronic carriers of hepatitis B virus. *Gut* 1999;45:613-7. ([Abstract](#))
- Danta M, Brown D, Bhagani S, et al. Recent epidemic of acute hepatitis C virus in HIV-positive men who have sex with men linked to high-risk sexual behaviours. *Aids* 2007;21:983-91. ([Abstract](#))
- de Ledinghen V, Trimoulet P, Mannant PR, et al. Outbreak of hepatitis C virus infection during sclerotherapy of varicose veins: long-term follow-up of 196 patients (4535 patient-years). *J Hepatol* 2007;46:19-25. ([Abstract](#))
- Di Bisceglie AM. Hepatitis C and hepatocellular carcinoma. *Hepatology* 1997;26:34S-38S. ([Abstract](#))
- Fattovich G, Giustina G, Degos F, et al. Morbidity and mortality in compensated cirrhosis type C: a retrospective follow-up study of 384 patients. *Gastroenterology* 1997;112:463-72. ([Abstract](#))
- Fissell RB, Bragg-Gresham JL, Woods JD, et al. Patterns of hepatitis C prevalence and seroconversion in hemodialysis units from three continents: the DOPPS. *Kidney Int* 2004;65:2335-42.
- Francois M, Dubois F, Brand D, et al. Prevalence and significance of hepatitis C virus (HCV) viremia in HCV antibody-positive subjects from various populations. *J Clin Microbiol* 1993;31:1189-93. ([Abstract](#))
- Gebo KA, Herlong HF, Torbenson MS, et al. Role of liver biopsy in management of chronic hepatitis C: a systematic review. *Hepatology* 2002;36:S161-71.
- Gitto S, Micco L, Conti F, Andreone P, Bernardi M. Alcohol and viral hepatitis: A mini-review. *Dig Liver Dis* 2009; 41:67-70. ([Abstract](#))
- Haley RW, Fischer R. Commercial tattooing as a potentially important source of hepatitis C infection. *Clinical epidemiology of 626 consecutive patients unaware of their hepatitis C serologic status*. *Medicine (Baltimore)* 2001;80:134-51. ([Abstract](#))
- Hatzakis A, Wait S, Bruix J, et al. The state of hepatitis B and C in Europe: report from the hepatitis B and C summit conference\*. *J Viral Hepat*. 2011; 18 Suppl 1:1-16. ([Abstract](#))

- Hraber P, Kuiken C, Yusim K. Evidence for human leukocyte antigen heterozygote advantage against hepatitis C virus infection. *Hepatology* 2007;46:1713-21. (Abstract)
- Jonsson JR, Purdie DM, Clouston AD, Powell EE. Recognition of genetic factors influencing the progression of hepatitis C : potential for personalized therapy. *Mol Diagn Ther* 2008;12:209-18. (Abstract)
- Lauer GM, Walker BD. Hepatitis C virus infection. *N Engl J Med* 2001;345:41-52. (Abstract)
- Lim YS, Kim WR. The global impact of hepatic fibrosis and end-stage liver disease. *Clin Liver Dis* 2008;12:733-46. (Abstract)
- Martinot-Peignoux M, Boyer N, Cazals-Hatem D, et al. Prospective study on anti-hepatitis C virus-positive patients with persistently normal serum alanine transaminase with or without detectable serum hepatitis C virus RNA. *Hepatology* 2001;34:1000-5. (Abstract)
- Mathurin P, Moussalli J, Cadranel JF, et al. Slow progression rate of fibrosis in hepatitis C virus patients with persistently normal alanine transaminase activity. *Hepatology* 1998;27:868-72. (Abstract)
- Merican I, Sherlock S, McIntyre N, Dusheiko GM. Clinical, biochemical and histological features in 102 patients with chronic hepatitis C virus infection. *Q J Med* 1993;86:119-25. (Abstract)
- Mitsui T, Iwano K, Masuko K, et al. Hepatitis C virus infection in medical personnel after needlestick accident. *Hepatology* 1992;16:1109-14. (Abstract)
- MMWR. Updated U.S. Public Health Service Guidelines for the Management of Occupational Exposures to HBV, HCV, and HIV and Recommendations for Postexposure Prophylaxis. *MMWR Recomm Rep* 2001;50:1.
- Ohto H, Terazawa S, Sasaki N, et al. Transmission of hepatitis C virus from mothers to infants. The Vertical Transmission of Hepatitis C Virus Collaborative Study Group. *N Engl J Med* 1994;330:744-50. (Abstract)
- Pembrey L, Newell ML, Tovo PA. The management of HCV infected pregnant women and their children European paediatric HCV network. *J Hepatol* 2005;43:515-25. (Abstract)
- Pereira BJ, Milford EL, Kirkman RL, Levey AS. Transmission of hepatitis C virus by organ transplantation. *N Engl J Med* 1991;325:454-60. (Abstract)
- Planas R, Balleste B, Alvarez MA, et al. Natural history of decompensated hepatitis C virus-related cirrhosis. A study of 200 patients. *J Hepatol* 2004;40:823-30. (Abstract)
- Pomper GJ, Wu Y, Snyder EL. Risks of transfusion-transmitted infections: 2003. *Curr Opin Hematol* 2003;10:412-8. (Abstract)
- Poynard T, Bedossa P, Opolon P. Natural history of liver fibrosis progression in patients with chronic hepatitis C. The OBSVIRC, METAVIR, CLINIVIR, and DOSVIRC groups. *Lancet* 1997;349:825-32. (Abstract)
- Puoti C, Castellacci R, Montagnese F, et al. Histological and virological features and follow-up of hepatitis C virus carriers with normal aminotransferase levels: the Italian prospective study of the asymptomatic C carriers (ISACC). *J Hepatol* 2002;37:117-23. (Abstract)
- Rauch A, Kutalik Z, Descombes P, et al. Genetic variation in IL28B is associated with chronic hepatitis C and treatment failure: a genome-wide association study. *Gastroenterology* 2010;138:1338-1345. (Abstract)
- RKI. Hepatitis C: RKI-Ratgeber Infektionskrankheiten. *Epidemiologisches Bulletin* 2004;17:141.
- Roth D, Zucker K, Cirocco R, et al. The impact of hepatitis C virus infection on renal allograft recipients. *Kidney Int* 1994;45:238-44. (Abstract)
- Sangiovanni A, Prati GM, Fasani P, et al. The natural history of compensated cirrhosis due to hepatitis C virus: A 17-year cohort study of 214 patients. *Hepatology* 2006;43:1303-10. (Abstract)
- Schmidt AJ, Rockstroh JK, Vogel M, et al. Trouble with bleeding: risk factors for acute hepatitis C among HIV-positive gay men from Germany--a case-control study. *PLoS One* 2011;6:e17781. (Abstract)
- Sterling RK, Stravitz RT, Luketic VA, et al. A comparison of the spectrum of chronic hepatitis C virus between Caucasians and African Americans. *Clin Gastroenterol Hepatol* 2004;2:469-73. (Abstract)
- Sutton AJ, Hope VD, Mathei C, et al. A comparison between the force of infection estimates for blood-borne viruses in injecting drug user populations across the European Union: a modelling study. *J Viral Hepat* 2008;15:809-16. (Abstract)

## 54 Hepatology 2012

- Svrtlih N, Jevtovic D, Simonovic J, et al. Older age at the time of liver biopsy is the important risk factor for advanced fibrosis in patients with chronic hepatitis C. *Hepatogastroenterology* 2007;54:2324-7. ([Abstract](#))
- Thomas DL, Thio CL, Martin MP, et al. Genetic variation in IL28B and spontaneous clearance of hepatitis C virus. *Nature* 2009;461:798-801. ([Abstract](#))
- Tong MJ, el-Farra NS, Reikes AR, Co RL. Clinical outcomes after transfusion-associated hepatitis C. *N Engl J Med* 1995;332:1463-6. ([Abstract](#))
- Vandelli C, Renzo F, Romano L, et al. Lack of evidence of sexual transmission of hepatitis C among monogamous couples: results of a 10-year prospective follow-up study. *Am J Gastroenterol* 2004;99:855-9. ([Abstract](#))
- Vogel M, Deterding K, Wiegand J, Grüner NH, Baumgarten A, Jung MC, et al. Hep-Net. Initial presentation of acute hepatitis C virus (HCV) infection among HIV-negative and HIV-positive individuals-experience from 2 large German networks on the study of acute HCV infection. *Clin Infect Dis*. 2009;49:317-9.
- Vogt M, Lang T, Frosner G, et al. Prevalence and clinical outcome of hepatitis C infection in children who underwent cardiac surgery before the implementation of blood-donor screening. *N Engl J Med* 1999;341:866-70. ([Abstract](#))
- Wasley A, Grytdal S, Gallagher K. Surveillance for acute viral hepatitis--United States, 2006. *MMWR Surveill Summ* 2008;57:1. ([Abstract](#))
- WHO, Factsheet No 164, June 2011. <http://goo.gl/YcLTU>, accessed January 10, 2012.
- Wiese M, Berr F, Lafrenz M, Porst H, Oesen U. Low frequency of cirrhosis in a hepatitis C (genotype 1b) single-source outbreak in germany: a 20-year multicenter study. *Hepatology* 2000;32:91-6.
- Zignego AL, Craxi A. Extrahepatic manifestations of hepatitis C virus infection. *Clin Liver Dis* 2008;12:611-36. ([Abstract](#))
- Zimmer V, Lammert F. Genetics and epigenetics in the fibrogenic evolution of chronic liver diseases. *Best Pract Res Clin Gastroenterol*. 2011 Apr;25:269-80. ([Abstract](#))

## 4. Hepatitis E: an underestimated problem?

*Sven Pischke and Heiner Wedemeyer*

### Introduction

Hepatitis E is an inflammatory liver disease caused by the hepatitis E virus (HEV), which is endemic in many tropical countries. Hepatitis E has been considered to be a travel-associated, acute, self-limiting liver disease that only causes fulminant hepatic failure in specific, high-risk groups. It has recently been estimated that HEV infection causes approximately 70,000 deaths each year worldwide (Rein 2011). In recent years sporadic cases of HEV infections have emerged also in industrialized countries, mostly caused by HEV genotype 3, for which zoonotic transmission has been described (Pischke 2010b).

In immunocompetent individuals infection with HEV usually leads to a clinically silent seroconversion or to an acute self-limited inflammation of the liver. In pregnant women and patients with pre-existing chronic liver diseases cases of fulminant liver failure by HEV infection are reported (Pischke 2010b).

Moreover, cases of chronic HEV infection associated with progressive liver disease have been described in several cohorts of immunocompromised individuals. In this context, diagnosis of HEV infection should rely on detection of HEV RNA, as testing for HEV-specific antibodies may lack sensitivity (Pischke 2010c).

Therapeutic options for chronic hepatitis E include reduction of immunosuppressive medication (Kamar 2011a), treatment with  $\alpha$ -interferon (Haagsma 2010, Kamar 2010a) or therapy with ribavirin (Kamar 2010b, Mallet 2010).

Recently, results of a large Phase III study were presented investigating a novel recombinant HEV vaccine in China. The vaccine had an efficacy to prevent acute symptomatic hepatitis E of >90% (Zhu 2010). It is unknown yet if and when this vaccine might become available for other countries.

### HEV: genetic characteristics of the virus

The hepatitis E virus is a non-enveloped, single-stranded RNA virus classified into the family of *Hepeviridae* and its own genus *Hepevirus* (Pischke and Wedemeyer 2010). There are 5 known genotypes. The HEV genome includes two short non-coding regions surrounding three open reading frames (ORF1 to 3). These ORFs contain the genetic information for various proteins that are necessary for capsid

formation, virus replication and infectivity of HEV. Various HEV isolates have been differentiated by phylogenetic analysis based on a hypervariable region within ORF1 (Meng 1999). Four of five HEV genotypes are able to infect humans, while genotype 5, called “avian HEV”, has only been detected in birds.

HEV genotype 1 is responsible for endemic and epidemic infections by HEV in Asia, while genotype 2 is endemic in Africa and Mexico (Figure 1). These genotypes are usually transmitted orally-faecally by contaminated drinking water under conditions of poor sanitation. There is no known animal reservoir for these genotypes (Pischke 2010b).

HEV genotype 3 can be found in humans and animals in Europe, the US and Asia (Pischke 2010b). For this genotype zoonotic transmission, foodborne or by contact with infected animals has been described. HEV genotype 3 has been identified in pigs, wild boars, shellfish, deer, oysters, cats, rats and various rodents (Pischke 2010b). Genotype 4 has also been detected in both humans and pigs in Asia (Geng 2009) and Europe (Hakze-van der Honing 2011).

Foodborne transmission can be avoided by cooking meat above 60°C, which inactivates the virus (Emerson 2005).

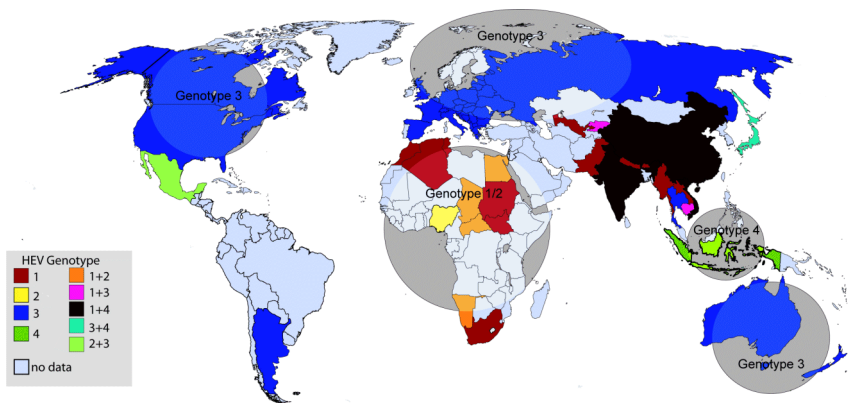


Figure 1. Worldwide distribution of HEV genotypes.

## Diagnosis of hepatitis E

In immunocompetent patients the diagnosis of hepatitis E is based on the detection of HEV-specific antibodies. While IgG antibodies indicate acute and past HEV infections, IgM antibodies can only be found in patients with acute infections (Pischke and Wedemeyer 2010). There are different commercial assays available for detection of HEV-specific antibodies. Comparison of six of these assays revealed a wide variation of diagnostic sensitivities and specificities as well as interassay disagreements (Drobeniuc 2010). Thus, some of the remarkable discrepancies in HEV seroprevalence rates reported in different studies may be explained by varying sensitivities of the respective assays.

HEV-specific IgG antibodies can be detected in patients with previous contact with HEV. They do not differentiate between ongoing HEV infection and past contact with the virus. To prove current infection the detection of HEV RNA by PCR has been established. Numerous assays using different primers have been



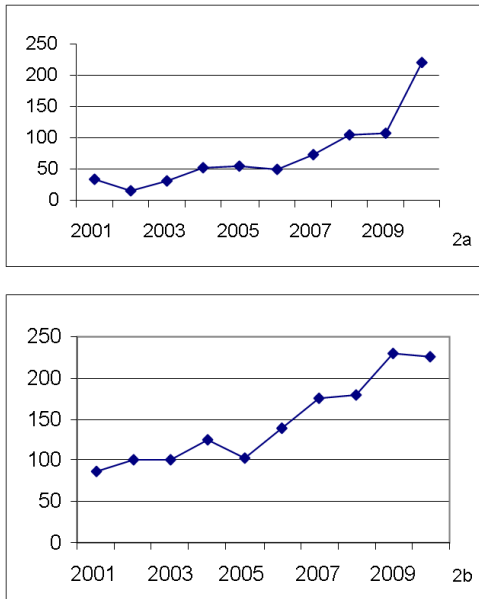
developed (Meng 1999, Zhao 2007). Furthermore, few quantitative PCR assays have been described (Ahn 2006, Enouf 2006).

In immunocompromised individuals, diagnosis of HEV infection may only be based on the detection of HEV RNA as seroassays lack sensitivity especially in the early phase of infection (Pischke 2010c). HEV RNA can not only be detected in serum samples but also in stool (Pischke 2010b) and thus infectivity of HEV infected persons can be determined by investigating stool for HEV RNA.

## Worldwide distribution of HEV infections

In the last few years an increasing frequency of diagnosed cases of HEV infections has been reported from various industrialised countries (Pischke 2010b). The presence of HEV RNA in urban sewage samples from Spain, the US and France has been shown, suggesting that HEV may be more prevalent in industrialised countries than previously assumed (Clemente-Casares 2003). In each of these three countries it was possible to discover HEV contamination in sewage samples in a notably high frequency. These findings may partially explain the huge gap between seroprevalence rates and the rather low numbers of diagnosed and reported cases of acute hepatitis E in Western countries. For example, Germany has a seroprevalence rate of 2% in a population of 80 million individuals (representing 1.6 million persons with possible previous HEV infection) but only about 200 cases of hepatitis E are diagnosed and reported each year (Pischke 2011a, Pischke 2010b). The mismatch between high seroprevalence rates and the low number of symptomatic cases has also been investigated in a recent study from Egypt. 919 anti-HEV seronegative individuals from rural Egypt were followed and, interestingly, 3.7% (n=34) of these individuals seroconverted to anti-HEV within 11 months of follow up (Stoszek 2006). However, none of these 34 individuals suffered from symptomatic hepatitis E. This finding corresponds with data from a recently published large vaccine study performed in China where very few of the patients in the placebo group who seroconverted during a follow-up period developed symptomatic acute hepatitis E (Zhu 2010). Overall, these data suggest that far less than 5% of all contacts with HEV lead to symptomatic hepatitis E (Wedemeyer and Pischke 2011).

Even so, a rapid increase in reported HEV infections has been recognized in several industrialized countries over the last 10 years. To investigate the potential underlying reasons for this phenomenon, we analyzed the time trend of the anti-HEV seroprevalence in healthy German individuals versus the number of reported cases of acute hepatitis E. Even though the number of reported cases increased more than 5-fold over the last ten years (Figure 1), the anti-HEV IgG seroprevalence rate remained rather stable over the last 15 years (Pischke 2011a). In contrast, the number of scientific articles on HEV infections published in PubMed increased sharply during the same period (Figure 1). These findings could indicate that the increase of reported HEV cases in Germany and other industrialized countries is based on an increased awareness associated with more frequent diagnosis of hepatitis E but not a true increase in incidence rates (Pischke 2011a).



**Figure 2.** Number of reported HEV infections in Germany over the last decade (Figure 2a) and number of publications on HEV over the same time period (Figure 2b).

## Transmission of HEV

The vast majority of HEV infections worldwide happens via the *faecal-oral route* (Figure 2). Patient-to-patient transmission is very rare but has been described from a large outbreak in Northern Uganda (Teshale 2011) and from hematology wards in Europe (Pischke 2010b). **Bloodborne transmission** of HEV has been suggested in the late nineties (Fainboim 1999). Subsequent studies from Hong Kong, Japan, Great Britain and France confirmed blood transfusions as a possible source of HEV transmission (Pischke 2010b). A single case of HEV **transmission by transplantation** of a liver graft from a patient with occult hepatitis E has been reported (Schlosser 2011).

**Zoonotic transmission** of HEV has recently been assumed to be the main source of HEV infections in industrialized countries (Figure 3). Both direct contact with HEV-infected domestic animals and foodborne transmission are possible (Pischke 2010b). Commercial food products such as pig meat may be contaminated with HEV as shown in studies from the Netherlands, France and Germany (Colson 2010, Melenhorst 2007, Wenzel 2011). Meat should be heated to over 70°C to prevent foodborne HEV infections (Emerson 2005).

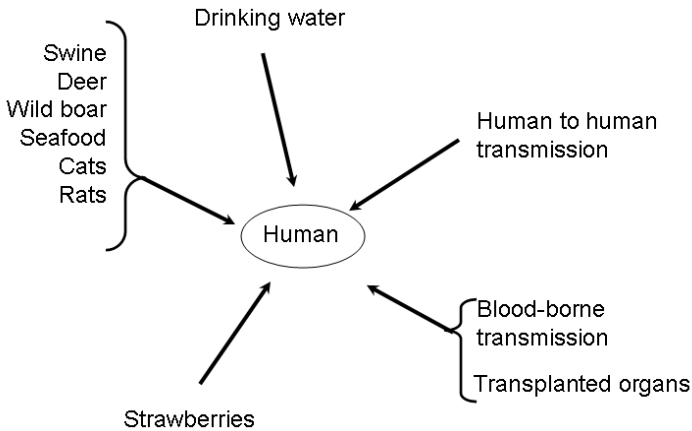


Figure 3. Possible sources of HEV infection.

## Acute hepatitis E in immunocompetent individuals

In the vast majority of cases, contact with HEV takes an asymptomatic course (Stoszek 2006, Wedemeyer and Pischke 2011), especially if the contact happens during childhood (Buti 2008). Immunocompetent individuals should be able to clear the virus spontaneously. In symptomatic cases the incubation period of HEV infections ranges from three to eight weeks with a mean of 40 days (Pischke 2010b). The peak of HEV viremia can be detected in the early phase of infection while the peak of ALT elevations usually occurs around 6 weeks after infection (Pischke 2010b).

*Initial symptoms in acute hepatitis E* are typically unspecific and can include flu-like myalgia, arthralgia, weakness and vomiting. In some patients jaundice, itching, uncoloured stool and darkened urine occur accompanied by elevation of liver transaminases, bilirubin, alkaline phosphatase and gamma-glutamyltransferase.

HEV infection can lead to *more severe acute liver disease in pregnant women* or patients with underlying chronic liver diseases progressing to fulminant hepatic failure in individual cases (Pischke 2010b). Possible explanations for the severe courses in pregnant women are hormonal and immunological changes during pregnancy (Navaneethan 2008). Recently an association between reduced expression of the progesterone receptor and fatal outcome of hepatitis E in pregnant women has been reported (Bose 2011).

Single cases of *prolonged courses of HEV infection* in immunocompetent individuals with up to two years of viremia have been described in the US (Mallet 2010), Spain (Gonzalez Tallon 2011) and China (Liu and Liu 2011). However, no case of HEV-associated liver cirrhosis or development of hepatocellular carcinoma has been reported in immunocompetent individuals.

## Acute and chronic HEV infections in organ transplant recipients

Chronic courses of HEV infections have been described in European liver or kidney transplant recipients since 2008 (Gerolami 2008, Haagsma 2009, Kamar 2008, Pischke 2010c). 14 cases of acute hepatitis E were initially reported in kidney- and liver-transplanted patients from southwest France (Kamar 2008). Eight of them developed a chronic course leading to persistently elevated ALT levels, significant histological activity and fibrosis after a follow-up of more than 12 months (range 10 to 18). Subsequently, additional cases of chronic HEV infections have been reported in transplant patients by several groups (Pischke and Wedemeyer 2010), clearly demonstrating that chronic hepatitis E can be associated with progressive liver disease in patients after organ transplantation (Kamar 2011c).

A study from Germany examined 226 liver-transplanted patients and 129 patients with chronic liver disease to evaluate the frequency of chronic HEV infections in liver transplant recipients in a low endemic country (Pischke 2010c). All patients were tested for HEV RNA and anti-HEV IgG. Two cases of chronic HEV infections in liver transplanted patients were identified showing different courses. One of them developed significant liver fibrosis (ISHAK F3) within less than 2 years. Both patients were infected with HEV genotype 3. The possibility of reverse zoonotic transmission was experimentally confirmed by infecting pigs with the patient's blood. HEV RNA was detectable in various organs of the pigs including muscle. Thus, these findings further support the recommendations that eating uncooked meat should be avoided by organ transplant recipients as this may represent a source for acquiring HEV infection.

A recent study summarized retrospective data on hepatitis E in transplant recipients in 17 centres. Overall, 85 cases of HEV infections were described and 56 (66%) patients developed chronic hepatitis E. Of note, chronicity was associated with the use of tacrolimus and with low platelet count (Kamar 2011c). However it has to be considered that the vast majority of patients had been recruited by one center (Toulouse) and experiences from other regions and transplant centres need to be reported.

Chronic courses of HEV infection have also been reported in heart transplant recipients (de Man 2011, Pischke 2011b). Overall, all recipients of solid organ transplant with elevated liver enzymes should be tested for HEV RNA unless other obvious reasons already explain the hepatitis. In immunosuppressed patients testing for HEV RNA should be applied as antibody testing may lack sensitivity.

## Hepatitis E in patients with HIV infection

Chronic hepatitis E was described for the first time in a patient with underlying HIV infection in 2009 (Dalton 2009). This patient had a CD4 T cell count of less than 200 cells and high HIV RNA levels (>100,000 copies/ml). However, subsequent studies from Spain (n=93) (Madejon 2009), Germany (n=123) (Pischke 2010a) and England (n=138) (Keane 2012) could not identify cases of chronic hepatitis in HIV-infected individuals. HEV RNA was detected for more than 10 months in only one out of 184 HIV-positive individuals in France (Kaba 2010). This patient had particularly low CD4 counts (<50 cells/mm) while two additional patients with

higher CD4 levels were able to clear HEV spontaneously. Thus, persistent HEV infection is rarely observed in HIV-infected patients and only subjects with strongly impaired immune system seem to be at risk for chronic hepatitis E.

## Extrahepatic manifestations of hepatitis E

There is some evidence that HEV infections maybe associated with extrahepatic manifestations. One case report described muscular weakness and a pyramidal syndrome in a kidney transplant recipient with persistent HEV infection (Kamar 2011b). Moreover, neurological disorders including polyradiculopathy, Guillain-Barre syndrome, bilateral brachial neuritis, encephalitis or proximal myopathy, have been reported in patients with acute and chronic HEV infections (Kamar 2011b). The underlying mechanisms and the clinical relevance of this association require further investigation.

## Treatment of chronic hepatitis E

Treatment options for chronic hepatitis include reduction of immunosuppression, administration of pegylated-interferon  $\alpha$  with ribavirin. The first step in the treatment of chronic HEV infection should be to evaluate if it is possible to reduce the immunosuppressive medication (Pischke and Wedemeyer 2010). Reduction of immunosuppression in 16 solid organ transplant recipients with chronic hepatitis E led to clearance of HEV in 4 cases (25%) (Kamar 2011a). A second possible treatment option is the use of pegylated-interferon  $\alpha$  (Haagsma 2010, Kamar 2010a). Treatment durations varied between 3 and 12 months. Overall, 4 out of 5 patients were successfully treated with sustained clearance of HEV RNA. However, the use of interferon can be associated with significant side effects and may cause rejection in organ transplant recipients. Interferon  $\alpha$  is therefore not recommended in heart or kidney transplant recipients. The antiviral efficacy of ribavirin monotherapy has been evaluated by two French groups (Kamar 2010b, Mallet 2010). A sustained virological response was observed in 2/2 and 4/6 treated patients, respectively. Ribavirin has also been used in a not-transplanted patient with severe acute hepatitis E who showed rapid improvement of symptoms and liver function tests during treatment (Gerolami 2011).

## Vaccination

No commercial HEV vaccine is currently available. A vaccine developed by GSK and the Walter Reed Army Institute that was successfully tested in a Phase II study (Shrestha 2007). However, this vaccine has not been further developed. A group from China reported data recently from a very large successful Phase III vaccine trial (Zhu 2010). This trial included almost 110,000 individuals who received either a recombinant HEV vaccine ("HEV 239") or placebo. The vaccine efficacy after three doses was 100%. It is currently not known if and when this vaccine will become available in China and other countries. Moreover, the efficacy of this vaccine needs to be evaluated in special risks groups such as patients with end-stage liver disease or immunosuppressed individuals. It is also unknown if HEV-239 also protects from HEV genotype 3 infection (Wedemeyer and Pischke 2011).

## Conclusions/Recommendations

- The prevalence of chronic HEV infections in liver transplant recipients depends on the general prevalence in the population and is low in most industrialized countries. However, chronic hepatitis E occurs and needs to be considered in the differential diagnosis of graft hepatitis as persistent HEV infection can be associated with progressive graft hepatitis and the development of liver cirrhosis. Currently all reported cases of chronic HEV infections in transplant recipients are caused by HEV genotype 3. It is not known if chronic hepatitis E can also be caused by the other genotypes.
- The diagnosis of HEV infection should not be based on serological assays alone in organ transplant recipients as these assays may lack sensitivity. Detection of HEV RNA by PCR in serum or stool represents the gold standard to determine the diagnosis of HEV infection.
- Organ transplant recipients and other immunocompromised individuals should avoid eating uncooked meats to avoid infection with HEV.
- Additional studies investigating the use of ribavirin for treatment of chronic hepatitis E are necessary.
- The relevance of extrahepatic manifestations associated with acute or chronic HEV infections needs further examination.

## References

- Ahn JM, Rayamajhi N, Gyun Kang S, Sang Yoo H. Comparison of real-time reverse transcriptase-polymerase chain reaction and nested or commercial reverse transcriptase-polymerase chain reaction for the detection of hepatitis E virus particle in human serum. *Diagn Microbiol Infect Dis* 2006;56:269-74. ([Abstract](#))
- Bose PD, Das BC, Kumar A, Gondal R, Kumar D, Kar P. High viral load and deregulation of the progesterone receptor signaling pathway: Association with Hepatitis E-related poor pregnancy outcome. *J Hepatol* 2011;54:1107-13. ([Abstract](#))
- Buti M, Plans P, Dominguez A, et al. Prevalence of hepatitis E virus infection in children in the northeast of Spain. *Clin Vaccine Immunol* 2008;15:732-4. ([Abstract](#))
- Clemente-Casares P, Pina S, Buti M, et al. Hepatitis E virus epidemiology in industrialized countries. *Emerg Infect Dis* 2003;9:448-54. ([Abstract](#))
- Colson P, Borentain P, Queyriaux B, et al. Pig liver sausage as a source of hepatitis E virus transmission to humans. *J Infect Dis* 2010;202:825-34. ([Abstract](#))
- Dalton HR, Bendall RP, Keane FE, Tedder RS, Ijaz S. Persistent carriage of hepatitis E virus in patients with HIV infection. *N Engl J Med* 2009;361:1025-7. ([Abstract](#))
- de Man RA, Pas SD, Osterhaus AD, Balk AH, Van der Eijk A. Diagnosis and clinical consequences of hepatitis E virus infection in orthotopic heart transplant recipients. *Hepatology* 2011; AASLD annual meeting.
- Drobeniuc J, Meng J, Reuter G, et al. Serologic assays specific to immunoglobulin M antibodies against hepatitis E virus: pangenotypic evaluation of performances. *Clin Infect Dis* 2010;51:e24-7. ([Abstract](#))
- Emerson SU, Arankalle VA, Purcell RH. Thermal stability of hepatitis E virus. *J Infect Dis* 2005;192:930-3. ([Abstract](#))
- Enouf V, Dos Reis G, Guthmann JP, et al. Validation of single real-time TaqMan PCR assay for the detection and quantitation of four major genotypes of hepatitis E virus in clinical specimens. *J Med Virol* 2006;78:1076-82. ([Abstract](#))
- Fainboim H, Gonzalez J, Fassio E, et al. Prevalence of hepatitis viruses in an anti-human immunodeficiency virus-positive population from Argentina. A multicentre study. *J Viral Hepat* 1999;6:53-7. ([Abstract](#))
- Geng Y, Wang C, Zhao C, et al. Serological Prevalence of Hepatitis E Virus in Domestic Animals and Diversity of Genotype 4 Hepatitis E Virus in China. *Vector Borne Zoonotic Dis* 2009. ([Abstract](#))

- Gerolami R, Borentain P, Raissouni F, Motte A, Solas C, Colson P. Treatment of severe acute hepatitis E by ribavirin. *J Clin Virol* 2011;52:60-2. ([Abstract](#))
- Gerolami R, Moal V, Colson P. Chronic hepatitis E with cirrhosis in a kidney-transplant recipient. *N Engl J Med* 2008;358:859-60. ([Abstract](#))
- Gonzalez Tallon AI, Moreira Vicente V, Mateos Lindemann ML, Achecar Justo LM. [Chronic hepatitis E in an immunocompetent patient.]. *Gastroenterol Hepatol* 2011.
- Haagsma E, Riezebos-Brilman A, Van den Berg AP, Porte RJ, Niesters HG. Treatment of chronic hepatitis E in liver transplant recipients with pegylated interferon alpha-2b. *Liver Transpl* 2010. [epub ahead of print] ([Abstract](#))
- Haagsma EB, Niesters HG, van den Berg AP, et al. Prevalence of hepatitis E virus infection in liver transplant recipients. *Liver Transpl* 2009;15:1225-8. ([Abstract](#))
- Hakze-van der Honing RW, van Coillie E, Antonis AF, van der Poel WH. First Isolation of Hepatitis E Virus Genotype 4 in Europe through Swine Surveillance in the Netherlands and Belgium. *PLoS One* 2011;6:e22673. ([Abstract](#))
- Kaba M, Richet H, Ravaux I, et al. Hepatitis E virus infection in patients infected with the human immunodeficiency virus. *J Med Virol* 2010;83:1704-16. ([Abstract](#))
- Kamar N, Abravanel F, Selves J, et al. Influence of immunosuppressive therapy on the natural history of genotype 3 hepatitis-E virus infection after organ transplantation. *Transplantation* 2011a;89:353-60. ([Abstract](#))
- Kamar N, Bendall RP, Peron JM, et al. Hepatitis E virus and neurologic disorders. *Emerg Infect Dis* 2011b;17:173-9. ([Abstract](#))
- Kamar N, Garrouste C, Haagsma EB, et al. Factors associated with chronic hepatitis in patients with hepatitis e virus infection who have received solid organ transplants. *Gastroenterology* 2011c;140:1481-9. ([Abstract](#))
- Kamar N, Izopet J, Cintas P, et al. Hepatitis e virus-induced neurological symptoms in a kidney-transplant patient with chronic hepatitis. *Am J Transplant* 2011d;10:1321-4. ([Abstract](#))
- Kamar N, Rostaing L, Abravanel F, et al. Pegylated Interferon-alpha for Treating Chronic Hepatitis E Virus Infection after Liver Transplantation. *Clin Infect Dis* 2010a.
- Kamar N, Rostaing L, Abravanel F, et al. Ribavirin Therapy Inhibits Viral Replication on Patients With Chronic Hepatitis E Virus Infection. *Gastroenterology* 2010b. ([Abstract](#))
- Kamar N, Selves J, Mansuy JM, et al. Hepatitis E virus and chronic hepatitis in organ-transplant recipients. *N Engl J Med* 2008;358:811-7. ([Abstract](#))
- Keane F, Gompels M, Bendall R, et al. Hepatitis E virus coinfection in patients with HIV infection. *HIV Med* 2012 Jan;13(1):83-88. ([Abstract](#))
- Liu L, Liu Y. Analysis of acute to chronic hepatitis E: 6-10 year follow-up. *Hepatogastroenterology* 2011;58:324-5. ([Abstract](#))
- Madejon A, Vispo E, Bottecchia M, Sanchez-Carrillo M, Garcia-Samaniego J, Soriano V. Lack of hepatitis E virus infection in HIV patients with advanced immunodeficiency or idiopathic liver enzyme elevations. *J Viral Hepat* 2009. ([Abstract](#))
- Mallet V, Louvet A, Chakvetadze C, et al. Ribavirin Treatment for Chronic Hepatitis E: a Case-Series. *Hepatology* 2010;52:919A-1020A.
- Melenhorst WB, Gu YL, Jaspers WJ, Verhage AH. Locally acquired hepatitis E in the Netherlands: associated with the consumption of raw pig meat? *Scand J Infect Dis* 2007;39:454-6. ([Abstract](#))
- Meng J, Cong M, Dai X, et al. Primary structure of open reading frame 2 and 3 of the hepatitis E virus isolated from Morocco. *J Med Virol* 1999;57:126-33. ([Abstract](#))
- Navaneethan U, Al Mohajer M, Shata MT. Hepatitis E and pregnancy: understanding the pathogenesis. *Liver Int* 2008;28:1190-9. ([Abstract](#))
- Pischke S, Heim A, Bremer B, et al. Hepatitis E: An Emerging Infectious Disease in Germany? *Z Gastroenterol* 2011a;49:1255-1257. ([Abstract](#))
- Pischke S, Ho H, Urbanek F, et al. Hepatitis E in HIV-positive patients in a low-endemic country. *J Viral Hepat* 2010a;17:598-9. ([Abstract](#))
- Pischke S, Potthoff A, Hauroder B, et al. [Hepatitis E virus infection: a paradigm shift?]. *Dtsch Med Wochenschr* 2010b;135:1129-33. ([Abstract](#))
- Pischke S, Suneetha PV, Baechlein C, et al. Hepatitis E virus infection as a cause of graft hepatitis in liver transplant recipients. *Liver Transpl* 2010c;16:74-82. ([Abstract](#))
- Pischke S, Voigtlaender T, Koenecke C, et al. Chronic hepatitis E in immunosuppressed patients beyond liver- and kidney transplantation. *Journal of Hepatology* 2011b;54, S1:495.
- Pischke S, Wedemeyer H. Chronic hepatitis E in liver transplant recipients: a significant clinical problem? *Minerva Gastroenterol Dietol* 2010;56:121-8. ([Abstract](#))

## 64 Hepatology 2012

- Rein DB, Stevens G, Theaker J, Wittenborn JS, Wiersma ST. The global burden of hepatitis E virus. *Hepatology* 2011. ([Abstract](#))
- Schlosser B, Stein A, Neuhaus R, et al. Liver transplant from a donor with occult HEV infection induced chronic hepatitis and cirrhosis in the recipient. *J Hepatol* 2011. ([Abstract](#))
- Shrestha MP, Scott RM, Joshi DM, et al. Safety and efficacy of a recombinant hepatitis E vaccine. *N Engl J Med* 2007;356:895-903. ([Abstract](#))
- Stoszek SK, Engle RE, Abdel-Hamid M, et al. Hepatitis E antibody seroconversion without disease in highly endemic rural Egyptian communities. *Trans R Soc Trop Med Hyg* 2006;100:89-94. ([Abstract](#))
- Teshale EH, Grytdal SP, Howard C, et al. Evidence of person-to-person transmission of hepatitis E virus during a large outbreak in Northern Uganda. *Clin Infect Dis* 2011;50:1006-10. ([Abstract](#))
- Wedemeyer H, Pischke S. Hepatitis: Hepatitis E vaccination-is HEV 239 the breakthrough? *Nat Rev Gastroenterol Hepatol* 2011;8:8-10. ([Abstract](#))
- Wenzel JJ, Preiss J, Schemmerer M, Huber B, Plentz A, Jilg W. Detection of hepatitis E virus (HEV) from porcine livers in Southeastern Germany and high sequence homology to human HEV isolates. *J Clin Virol* 2011. ([Abstract](#))
- Zhao ZY, Ruan B, Shao H, Chen ZJ, Liu SL. Detection of hepatitis E virus RNA in sera of patients with hepatitis E by polymerase chain reaction. *Hepatobiliary Pancreat Dis Int* 2007;6:38-42. ([Abstract](#))
- Zhu FC, Zhang J, Zhang XF, et al. Efficacy and safety of a recombinant hepatitis E vaccine in healthy adults: a large-scale, randomised, double-blind placebo-controlled, phase 3 trial. *Lancet* 2010;376:895-902. ([Abstract](#))



## 5. HBV Virology

*Maura Dandri, Jörg Petersen*

### Introduction

The human hepatitis B virus (HBV) is a small enveloped DNA virus causing acute and chronic hepatitis. Although a safe and effective vaccine has been available for the last two decades, HBV infection still represents a major global health burden, with about 350 million people chronically infected worldwide and more than 1 million deaths per year due to HBV-associated liver pathologies (Block 2007). Many epidemiological and molecular studies have shown that chronic HBV infection represents the main risk factor for hepatocellular carcinoma development (Shepard 2006, Lok 2004, Pollicino 2011). The rate for chronicity is approximately 5% in adult infections, but it reaches 90% in neonatal infections. HBV transmission occurs vertically and horizontally via exchange of body fluids. In serum, up to  $10^{12}$  HBV genome equivalents per ml serum can be found. Although HBV does not induce direct cytopathic effects under normal infection conditions (Wieland 2004, Thimme 2003), liver damage (fibrosis, cirrhosis, and eventually hepatocellular carcinoma) is believed to be induced by the ongoing immune reaction and a consistent inflammation of the liver (McMahon 2009, Chisari 2007).

HBV is the prototype member of the *Hepadnaviridae* family, which are the smallest DNA-containing, enveloped animal viruses known. Characteristic of HBV is its high tissue- and species-specificity, as well as a unique genomic organization with asymmetric mechanism of replication (Nassal 2008). Since all hepadnaviruses use a reverse transcriptase to replicate their genome, they are considered distantly related to retroviruses. Despite decades of research and significant progresses in understanding of the molecular virology of HBV, important steps of the infection, such as the mechanism and cellular receptor(s) mediating viral entry, have not yet been clarified (Glebe 2007). Only recently, innovative infection models and molecular techniques have opened new possibilities to investigate specific steps of the lifecycle, as well as the organization and the activity of the covalently closed circular DNA (cccDNA), the viral minichromosome serving as the template of HBV transcription in the nucleus of the infected hepatocytes, which enables maintenance of chronic HBV infection (Levrero 2009).

## Taxonomic classification and genotypes

The *Hepadnaviridae* form their own taxonomic group, since their biological characteristics are not observed in any other viral family. Based on host and phylogenetic differences, the family of *Hepadnaviridae* contains two genera: the *orthohepadnaviruses* infecting mammals, and the *avihepadnaviruses* that infect birds. To date, *orthohepadnaviruses* have been found in human (HBV), woodchuck (WHV) (Korba 1989), ground squirrel (GSHV), arctic squirrel (ASHV) and woolly monkey (WMHBV) (Lanford 1998). *Avihepadnaviruses* include duck HBV (DHBV) (Mason 1980), heron HBV (HHBV) (Sprengel 1988), Ross's goose HBV, snow goose HBV (SGHBV), stork HBV (STHBV) (Pult 2001) and crane HBV (CHBV) (Roggendorf 2007, Funk 2007, Dandri 2005b, Schaefer 2007).

Due to the lack of proofreading activity of the viral polymerase, misincorporation of nucleotide mutations occurs during viral replication. This has led to the emergence of eight HBV genotypes, A-H, which differ in more than 8% of the genome, as well as different subgenotypes, which differ by at least 4% (Fung and Lok 2004, Guirgis 2010). The HBV genotypes have different geographic distribution (Liaw 2010), with predominance of genotype A in northwestern Europe, North and South America, genotype B and C in Asia and genotype D in eastern Europe and in the Mediterranean basin. The less diffuse remaining genotypes are mostly found in West and South Africa (genotype E), in Central and South America (genotypes F and H), while genotype G has been detected in France and in the US (Pujol 2009). The phylogenetic tree of HBV genomes is reviewed elsewhere (Schaefer 2007)

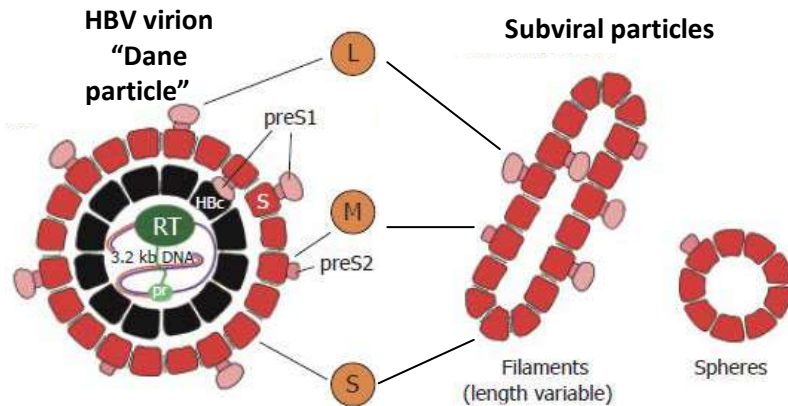
## HBV structure and genomic organization

Three types of viral particles can be visualized in the infectious serum by electron microscopy: the infectious virions and the subviral particles (SVPs). The infectious virus particles are the so-called Dane particles (Dane 1970), have a spherical, double-shelled structure of 42-44 nm containing a single copy of the viral DNA genome, covalently linked to the terminal protein of the virus. A hallmark of HBV infection is the presence of two additional types of particles, the spheres and the filaments, which are exclusively composed of hepatitis B surface proteins and host-derived lipids (Glebe and Urban 2007). Since they do not contain viral nucleic acids, the subviral particles are non-infectious. The spherical structures measure around 22 nm in diameter, while the filaments are similarly width, but display variable lengths (Figure 1).

The viral membrane contains three viral surface proteins and is acquired by the virus during budding into the endoplasmic reticulum (ER), whereas the viral particles are transported via the secretory pathways through the ER and Golgi. The surface proteins are named, according to their size, the preS1 (or large), the preS2 (or middle) and the S (or small), which corresponds to the HBsAg. As with nearly all enveloped viruses, the HBV particle also contains proteins of host origin (Glebe 2007, Urban 2010).

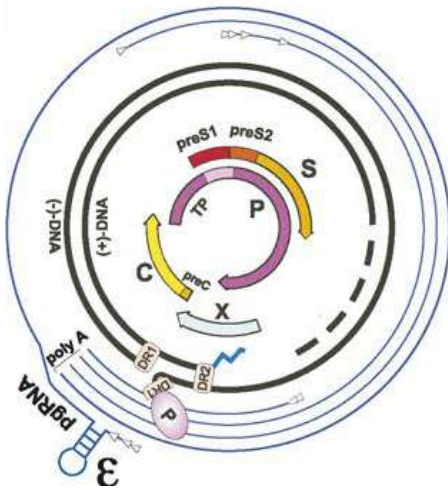
The HBV genome consists of a partially double-stranded relaxed circular DNA of approximately 3200 nucleotides in length, varying slightly from genotype to genotype, that in concert with the core protein (HBcAg) forms the nucleocapsids

(Nassal 2008). Within the Dane particle the negative strand of the viral DNA is present in full-length, thus carrying the complete genetic information. In contrast, the positive strand spans only  $\sim 2/3$  of the genome in length, whilst its 3' end is variable in size (Summers 1988, Lutwick 1977). The viral polymerase is covalently bound to the negative strand by a phosphotyrosine bond. At the 5' end of the positive strand a short RNA oligomer originating from the pre-genomic (pg) RNA residually remains bound covalently after the viral DNA synthesis. The negative strand also contains a small redundancy of 8-9 nucleotides in length on both the 5' end and the 3' end, named the R region. These redundant structures are essential for viral replication (Seeger 1986, Seeger 2000, Nassal 2008, Lee 2004).



**Figure 1. Schematic representation of the HBV virion and non-infectious empty subviral particles (filaments and spheres).** Within the nucleocapsid (HBcAg, shown in black) is depicted the partial double-stranded viral genome (rcDNA) covalently linked to the terminal protein of reverse transcriptase. The presence and distribution of the three surface proteins L (preS1 or large), M (preS2 or middle) and S (small) are shown both on HBV and subviral particles (adapted from Glebe 2007).

The HBV genome displays four major open reading frames (ORFs) that are organized in a unique and highly condensed way (Block 2007). As shown in Figure 2, all ORFs are in an identical orientation, partially overlap and are encoded by the negative strand. On the genome, 6 start codons, four promoters and two transcription-enhancing elements have been identified. The four major ORFs are: I) the preS/S, encoding the three viral surface proteins; II) the precore/core, encoding both the core protein, essential for the formation of the nucleocapsid, and the non-structural pre-core protein, also known as the secreted e-antigen (HBeAg); III) the pol ORF of the viral polymerase, which possesses reverse transcriptase, DNA polymerase and RNase H activities, and the terminal protein; and IV) the X ORF, coding for the small regulatory X protein, which has been shown to be essential *in vivo* for viral replication (Zoulim 1994, Lucifora 2011) and is capable of transactivating numerous cellular and viral genes. Characteristic of the 4 major HBV ORFs is that they utilize a single common polyadenylation signal motif (Nassal 2008). Thus, all RNA transcripts are polyadenylated and capped.



**Figure 2. Genome organization and transcripts of the human hepatitis B virus.** The outer thin lines represent the viral transcripts that initiate at different sites, under the control of distinct promoters, but are all terminated after a common polyadenylation site. The RNA signal on the terminally redundant pgRNA is indicated as a hairpin. The thick lines represent the rcDNA form of the genome as present in infectious virions. The 5' end of the minus-strand DNA is covalently linked to the terminal protein of the polymerase. The 5' end of the incomplete plus-strand DNA is constituted by an RNA oligo derived from the 5' end of pgRNA. DR1 and DR2 indicate the direct repeats. The inner arrows indicate the open reading frames (adapted from Nassal 2008).

## HBV structural and non-structural proteins

The three surface proteins (L, M, and S) are encoded from one open reading frame (PreS/S) which contains three start codons (one for the large, one for the middle and one for the small protein) but promotes the transcription of 2 mRNAs of 2.4 and 2.1 Kb, named preS and S RNAs (Glebe 2007). Notably, the preS/S ORF entirely overlaps with the polymerase open reading frame (Lee 2004). The three HBV envelope proteins share the C-terminal domain of the S-protein, while the M- and L-protein display progressive N-terminal extensions of 55 and, genotype-dependent, 107 or 118 amino acids (preS2 and preS1). The small envelope protein contains the hepatitis B surface antigen (HBsAg). In virions the stoichiometric ratio of L, M and S is about 1:1:4, while the more abundantly secreted non-infectious subviral particles (SVPs) contain only traces of L-protein (Bruss 2007). The envelope proteins are cotranslationally inserted into the ER membrane, where they aggregate, bud into the ER lumen, and are secreted by the cell, either as 22 nm subviral envelope particles (SVPs) or as 42 nm infectious virions (Dane particles), after having enveloped the DNA-containing nucleocapsids. The surface proteins of mammalian *Hepadnaviridae* have been shown to be N- and O-glycosylated (Schildgen 2004, Schmitt 2004). These glycosylations have been shown to be responsible for proper secretion of progeny viral particles. During synthesis, the preS1 domain of L is myristoylated and translocated through the ER. This modification and the integrity of the first 77 amino acids of preS1 have been shown

to be essential for infectivity (Glebe 2005, Nassal 2008) (Schulze 2010). Both spherical and filamentous SVPs are secreted into the blood of infected individuals in a  $10^3$ - $10^6$ -fold excess relative to the infectious particles. The biological function of the excess of SVPs in patients is not clear. It was suggested that SVPs might absorb the neutralizing antibodies produced by the host and hence increase the ability of the infectious particles to reach the hepatocytes. It has also been suggested that SVPs contribute to create a state of immune tolerance, which is a precondition for highly productive persistent infection.

In the cytoplasm, the core protein dimerises and self-assembles to form an icosahedral nucleocapsid. The full-length core protein is 183 amino acids in length and consists of an assembly domain and a nucleic acid-binding domain, which plays an active role in binding and packaging of the pregenomic RNA together with the viral polymerase, and thus enables the RT-polymerase/RNA complex to initiate reverse transcription within the newly forming nucleocapsids (Kann 1994, Kann 2007, Kann 1999, Daub 2002). The core protein can be phosphorylated by several kinases. This step along with the presence of the viral polymerase is important for the specific packaging of the pgRNA (Kann 1999, Porterfield 2010).

The viral polymerase is the single enzyme encoded by the HBV genome and is an RNA-dependent DNA polymerase with RNase H activity. The HBV polymerase consists of three functional domains and a so-called spacer region; the terminal protein (TP) is located at its N-terminal domain, and serves as a primer for reverse transcription of the pgRNA into a negative-strand DNA (Zoulim 1994, Nassal 2008). The spacer domain separates the terminal protein from the polymerase domains (Beck 2007)

Despite the occurrence of nucleotide mutations due to the lack of proofreading capacity of the HBV polymerase, the peculiar genomic organization of HBV, where most of the genes overlap, imposes stronger constraints on the amino acid sequence, which significantly reduces the occurrence of mutations in the absence of strong selective pressures. Nevertheless, it has been shown that antiviral therapy with nucleoside analogs can promote the selection of nucleotide mutations within conserved domains of the reverse transcriptase, which lead to mutations also on the amino acid sequence of the envelope proteins. Changes on the HBsAg structure may lead to reduced binding of anti-HBs antibodies, and hence, they may favour the selection of antibody escape mutants (Harrison 2006).

HBV also produces distinct non-structural proteins whose exact functions are not fully elucidated. Besides the production of large amounts of empty SVPs, HBV produces and secretes a non-particulate form of the nucleoprotein, the precore protein, or HBeAg, which is not required for viral infection or replication, but appears to act as a decoy for the immune system, and hence, has tolerogenic functions in promoting viral persistence in the neonates of viremic mothers (Chen 2005, Visvanathan 2006). The precore and core proteins are translated from 2 distinct RNA species that have different 5' initiation sites: the precore RNA and the pgRNA. Indeed, the precore transcript, which also contains the full core gene, encodes a signal sequence that directs the precore protein to the lumen of the endoplasmic reticulum, where it is post-translationally processed. Here, the precore protein undergoes N- and C-terminal cleavage to produce the mature HBeAg form (p17), which is then secreted as a monomeric protein. Interestingly, 20 to 30% of the mature protein is retained in the cytoplasm, where it may antagonise TLR

signaling pathways and so contribute to the suppression of the host innate immune responses (Lang 2011). As an important marker for active viral replication, the HBeAg is widely used in molecular diagnostics (Chen 2005, Hadziyannis 2006).

The X protein is a multifunctional regulatory protein with transactivating and pro-apoptotic potential, which can modify several cellular pathways (Bouchard 2004) and act as a carcinogenic cofactor (Kim 1991, Dandri 1996, Slagle 1996). Numerous DNA transfection experiments have shown that over-expression of the X protein (HBx) causes transactivation of a wide range of viral elements and cellular promoters (Bouchard 2004). The evidence that HBx responsive enhancers/promoters do not share any common DNA sequence and that HBx does not bind double-stranded DNA suggested that HBx may exert its transactivating activity through protein-protein interactions. *In vitro* studies have shown that HBx can affect various cytoplasmic signal transduction pathways by activating the Src kinase, Ras/Raf/MAP kinase, members of the protein kinase C, as well as Jak1/STAT. Furthermore, *in vitro* binding studies show that HBx can regulate the proteasome function, and thus, may control the degradation of cellular and viral proteins (Zhang 2004). It has also been reported that HBx can affect mitochondria function, by altering its transmembrane potential, as well as that HBx can modulate calcium homeostasis (Bouchard 2001, Nassal 2008, Yang 2011).

Although the exact role of HBx in the context of HBV infection has not been clarified, several lines of evidence obtained first using the woodchuck model (Zoulim 1994) and more recently using uPA/SCID mice (Tsuge 2010) and HepaRG<sup>TM</sup> cells (Lucifora 2011), have convincingly shown that HBx is required to initiate HBV replication and to maintain virion productivity. Notably, these studies indicated that despite the establishment of comparable cccDNA amounts, transcription of HBV RNAs was dramatically impaired in cells inoculated with HBV X, indicating that HBx is essential for viral transcription. These findings are also in agreement with data showing that HBx is recruited to the cccDNA minichromosome, where it appears to be involved in epigenetic control of HBV replication (Belloni 2009, Levrero 2009). In addition, HBx has been shown to enhance encapsidation of the pgRNA by increasing phosphorylation of the core protein (Melegari 2005), indicating that HBx may support virion productivity in various steps of the HBV life cycle.

Most HBV-related HCC show the integration of HBV DNA sequences including the X gene (Brechot 2004, Pollicino 2011, Lupberger 2007). Although HBV integrated forms are frequently rearranged and hence not compatible with the expression of functional proteins, HBx sequences deleted in the C-terminal portion have been frequently detected in tumoral cells (Iavarone 2003). In virus-associated cancers, viral proteins have been shown to participate in epigenetic alterations by disturbing the host DNA methylation system. Interestingly, a study suggested that the HBV regulatory X protein is a potent epigenetic modifying factor in the human liver, which can modulate the transcription of DNA methyltransferases required for normal levels of genomic methylation and maintenance of hypomethylation of tumor suppressor genes (TSGs) (Park 2007). HBx-promoted hypermethylation of TSGs suggests a novel mechanism by which this promiscuous transactivating protein may accelerate hepatocarcinogenesis (Kekule 1993, Dandri 1996).

## The HBV replication cycle

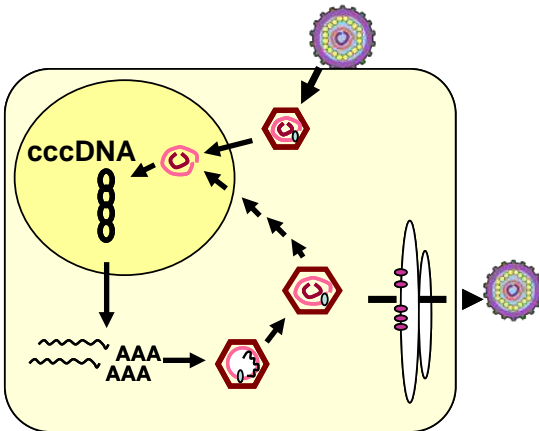
During the last 30 years, the generation of various HBV–transfected human hepatoma cell lines and the use of related HBV viruses, like the duck hepatitis B virus (DHBV) and the woodchuck hepatitis virus (WHV) have significantly contributed to elucidate many steps of the hepadnavirus replication cycle (Schultz 2004, Roggendorf 1995, Roggendorf 2007). Nevertheless, the lack of efficient *in vitro* infection systems and of easily accessible animal models has significantly hindered the identification of mechanisms and cellular factors mediating viral entry and uncoating in human hepatocytes. Although primary hepatocytes remain permissive *in vitro* for only a short time after plating, the availability of primary hepatocytes from tree-shrews (*Tupaia belangeri*) for infection studies with HBV and the closely-related woolly monkey hepatitis B virus (WM-HBV) (Kock 2001), and the discovery of a human hepatoma cell line (HepaRG) able to gain susceptibility for HBV infection upon induction of differentiation *in vitro* (Gripon 2002), have lately expanded our possibilities to functionally dissect the HBV entry process (Glebe 2007, Schulze 2010).

The first step in HBV infection appears to involve a non-cell-type specific primary attachment to the cell-associated heparan sulfate proteoglycans (Schulze 2007). This first reversible attachment step is then followed by an irreversible binding of the virus to a specific, but still unknown hepatocyte-specific receptor (Urban 2010, Glebe 2007). This step probably requires activation of the virus, resulting in exposure of the myristoylated N-terminus of the L-protein. Important determinants for infectivity within the HBV envelope proteins were identified using mutational analyses. These include 75 amino acids of the preS1 domain of the HBV L-protein, its myristoylation and the integrity of a region in the antigenic loop of the S domain (Gripon 2005, Engelke 2006). Potential HBV receptor candidates have been described in the past, but none of them has been confirmed in a functional assay (Glebe 2007). Recent studies indicated that cell polarization, in addition to the differentiation status of the hepatocytes, plays an important role in the infection process (Schulze 2011).

Upon binding to the cell membrane, two possible entry pathways have been proposed. Experimental evidence suggests that HBV can be either involved in an endocytosis process, followed by the release of the nucleocapsid from endocytic vesicles, or HBV may enter the hepatocytes after fusion of the viral envelope at the plasma membrane. As soon as the viral nucleocapsids are released into the cytoplasm, the viral relaxed circular partially double stranded DNA (rcDNA) with its covalently linked polymerase needs to enter the cell nucleus in order to convert the rcDNA genome into a covalently closed circular form (cccDNA) (Nassal 2008). Previous studies indicated that the viral capsids are transported via microtubules to the nuclear periphery (Rabe 2006). The accumulation of the capsids at the nuclear envelope would then facilitate interactions with nuclear transport receptors and adaptor proteins of the nuclear pore complex (Kann 2007). Although immature capsids may remain trapped within the nuclear baskets by the pore complexes, the mature capsids eventually disintegrate, permitting the release of both core capsid subunits and of the polymerase-viral DNA complexes, which diffuse into the nucleoplasm (Schmitz 2010).

Within the infected nuclei the establishment of productive HBV infection requires the removal of the covalently attached viral polymerase and completion of the positive-strand by the cellular replicative machinery to form the supercoiled cccDNA molecule, which is then incorporated into the host chromatin and serves as the template of viral transcription and replication (Nassal 2008, Newbold 1995). For the formation of the cccDNA, the terminal protein and one of the redundant terminal repeats present on the rcDNA need to be removed. So far it is assumed that cellular ligases and probably other enzymes involved in DNA repair mechanisms become active and convey the relaxed circular form into the cccDNA (Seeger 2000). Unlike the provirus DNA of retroviruses, the cccDNA does not need to be incorporated into the host genome. Nevertheless, integrations of HBV DNA sequences do occur, particularly in the course of hepatocyte turnover and in the presence of DNA damage, as has been shown in cell culture (Dandri 2002) and in the woodchuck system (Petersen 1998, Summers 2004, Mason 2005).

Disguised as a stable non-integrated minichromosome (Bock 1994, Bock 2001), the cccDNA utilizes the cellular transcriptional machinery to produce all viral RNAs necessary for protein production and viral replication, which takes place in the cytoplasm after reverse transcription of an over-length pregenomic RNA (pgRNA) (Figure 3).



**Figure 3. The HBV lifecycle.** Upon hepatocyte infection the nucleocapsid is released into the cytoplasm and the rcDNA transferred to the cell nucleus where it is converted into the cccDNA minichromosome. After transcription of the viral RNAs, the pgRNA is encapsidated and reverse-transcribed by the HBV polymerase. Through Golgi and ER apparatus the core particles acquire the envelope and are secreted. Via viral entry and retransporting of the newly synthesized HBV DNA into the cell nucleus, the cccDNA pool can be amplified.

Experimental DHBV infection studies indicate that the cccDNA can be formed not only from incoming virions, but also from newly synthesized nucleocapsids, which instead of being enveloped and secreted into the blood, are rather transported into the nucleus to ensure accumulation, and later maintenance, of the cccDNA pool (Zoulim 2005b, Nassal 2008). According to this scenario, multiple rounds of infection are not needed to establish a cccDNA pool in infected duck hepatocytes.



Moreover, expression of the DHBV viral large surface (LS) protein was shown to induce a negative-feedback mechanism, whereby the accumulation of the LS protein would be fundamental to shut off the cccDNA amplification pathway and redirect the newly synthesized rcDNA-containing nucleocapsids to envelopment and extracellular secretion (Kock 2010). Although this peculiar nuclear reentry mechanism has been clearly demonstrated for the duck HBV (Summers 1991, Nassal 2008, Wu 1990) and a high copy number of cccDNA molecules is generally detected in chronically infected ducks and woodchucks (1 to 50 copies/cell) (Zhang 2003, Dandri 2000), lower cccDNA intrahepatic loads are generally determined in human liver biopsies obtained from chronically HBV -infected patients (median 0.1 to 1 cccDNA copy/cell) (Werle-Lapostolle 2004, Wong 2004, Laras 2006, Volz 2007, Wursthorn 2006, Lutgehetmann 2008) and in chronically HBV-infected human-liver chimeric uPA/SCID mice (Petersen 2008, Lutgehetmann 2011a, Lutgehetmann 2011b, Lutgehetmann 2010), suggesting that different viral and host mechanisms may control cccDNA dynamics and cccDNA pool size in human infected hepatocytes (Levrero 2009). A recent study elegantly showed that HBV converted the rcDNA into cccDNA less efficiently than DHBV in the same human cell background (Kock 2010).

Although the formation of the cccDNA minichromosome is essential to establish productive infection, recent studies performed in uPA/SCID mice indicate that this step is achieved, initially, only in a minority of human hepatocytes. Indeed, three weeks post-infection, the intrahepatic cccDNA load is very low (ca. 1 copy/50 human hepatocytes) and only sporadic cells stain HBcAg-positive, while within 8 weeks the majority of human hepatocytes become infected. Thus, several weeks appear to be necessary for HBV to spread among human hepatocytes *in vivo*, even in the absence of adaptive immune responses (Dandri 2011).

HBV polymerase inhibitors do not directly affect cccDNA activity and various *in vitro* and *in vivo* studies support the notion that the cccDNA minichromosome is very stable in quiescent hepatocytes (Moraleda 1997, Dandri 2000, Dandri 2005, Lutgehetmann 2010). Thus, the significant decrease in cccDNA levels (approximately 1 log<sub>10</sub> reduction) generally determined after 1 year of therapy with polymerase inhibitors (Werle-Lapostolle 2004) is imagined to derive from the lack of sufficient recycling of viral nucleocapsids to the nucleus, due to the strong inhibition of viral DNA synthesis in the cytoplasm, and less incoming viruses from the blood. Nevertheless, cccDNA depletion is expected to require many years of nucleos(t)ide drug administration. Thus, despite the absence of detectable viremia, the persistence of the cccDNA minichromosome within the infected liver is responsible for the failure of viral clearance and the relapse of viral activity after cessation of antiviral therapy with polymerase inhibitors in chronically infected individuals. Furthermore, if viral suppression is not complete, the selection of resistant variants escaping antiviral therapy is likely to occur (Zoulim 2005a, Zoulim 2005b, Zoulim 2009). Resistant HBV genomes can be archived in infected hepatocytes when nucleocapsids produced in the cytoplasm by reverse transcription and containing resistant mutants are transported into the nucleus and added to the cccDNA pool. Under antiviral pressure, these variants will coexist with wild-type cccDNA molecules and function as templates for the production and possibly further selection of replication-competent resistant mutants, which will spread to

other hepatocytes and, eventually may even replace the wild-type cccDNA molecules in the liver (Zoulim 2006, Zoulim 2009).

During chronic HBV infection immune-mediated cell injury and compensatory hepatocyte proliferation may favour cccDNA decline and selection of cccDNA-free cells (Mason 2005, Zhang 2003, Thermet 2008). Notably, studies with the duck model show that antiviral therapy with polymerase inhibitors induce a greater cccDNA reduction in animals displaying higher hepatocyte proliferation rates (Addison 2002). cccDNA decrease was also determined in chronically WHV-infected woodchuck hepatocytes when cell turnover was induced *in vitro* by addition of cellular growth factors and viral replication was suppressed by adefovir treatment (Dandri 2000). Furthermore, the identification of uninfected cccDNA-negative cell clones containing “traces” of the infection in form of viral integrations indicate that cccDNA clearance without cell destruction can occur in chronically infected woodchucks (Mason 2005). Thus, in chronic infection, killing of hepatocytes may be instrumental not only to eliminate infected cells but also to induce hepatocyte proliferation which, in turn, may favour cccDNA loss (Dandri 2005, Lutgehetmann 2010). On the other hand, studies have shown that very low levels of cccDNA can persist indefinitely, possibly explaining lifelong immune responses to HBV despite clinical resolution of HBV infection (Rehermann 1996).

As mentioned previously, the cccDNA acts chemically and structurally as an episomal DNA with a plasmid-like structure (Bock 1994, Bock 2001, Newbold 1995), which is organized as a minichromosome by histone and non-histone proteins. Hence its function is regulated, similarly to the cellular chromatin, by the activity of various nuclear transcription factors, including transcriptional coactivators, repressors and chromatin modifying enzymes (Levrero 2009). Congruent with the fact that HBV infects hepatocytes, nearly all elements regulating viral transcription have binding sites for liver-specific transcription factors (Levrero 2009, Quasdorff 2008). Nevertheless, although a number of factors regulating viral transcription are known, the exact molecular mechanisms regulating HBV transcription are still poorly defined. Both messenger and pregenomic RNAs are transported into the cytoplasm, where they are respectively translated or used as the template for progeny genome production. Thus, the transcription of the pgRNA is the critical step for genome amplification and determines the rate of HBV replication. Identification of the factors affecting stability and transcriptional activity of the cccDNA in the course of infection and under antiviral therapy may assist in the design of new therapeutic strategies aimed at silencing and eventually depleting the cccDNA reservoir.

The next crucial step in HBV replication is the specific packaging of pgRNA, plus the reverse transcriptase, into newly forming capsids. The pgRNA bears a secondary structure – named the  $\epsilon$  structure - that is present at both the 5' and the 3' ends. The  $\epsilon$  hairpin loops at the 5' end are first recognized by the viral polymerase and act as the initial packaging signal (Bartenschlager 1992). Binding of polymerase to the RNA stem-loop structure  $\epsilon$  initiates packaging of one pgRNA molecule and its reverse transcription. The first product is single-stranded (ss) DNA of minus polarity; due to its unique protein priming mechanism, its 5' end remains covalently linked to the polymerase. The pgRNA is concomitantly degraded, except for its 5' terminal (~15–18 nucleotides which serve as primer for plus-strand DNA synthesis), resulting in rcDNA. The heterogeneous lengths of the plus-strand DNAs generated

by capsid-assisted reverse transcription may result from a non-identical supply of dNTPs inside individual nucleocapsids at the moment of their enclosure by the dNTP impermeable envelope. This predicts that intracellular cores produced in the absence of envelopment should contain further extended positive DNAs. Alternatively, space restrictions in the capsid lumen could prevent plus-strand DNA completion; in this view, further plus-strand elongation after infection of a new cell might destabilize the nucleocapsid and thus be involved in genome uncoating (Beck 2007, Nassal 2008)

The final replication step, the assembly and release of HBV Dane particles, is also not fully understood. The envelopment of the DNA-containing nucleocapsids requires a balanced coexpression of the S and L proteins in order to recruit the nucleocapsid to the site of budding. Although the role of the envelope proteins in regulating the amplification of cccDNA in HBV is not well-characterised, recent studies indicate that the lack of expression of the envelope proteins increased cccDNA levels, while coexpression of the envelope proteins not only favours the secretion of viral particles, but also limits the completion of the plus-strand (Lentz 2011).

## Animal models of HBV infection

Because of the narrow host range and the lack of easily accessible and robust *in vitro* infection systems the study of HBV biology has been limited. Consequently it has been attempted by researchers all over the world to establish animal models and cell culture systems that at least partially reproduce some stages of HBV infection and can be used, e.g., for the preclinical testing of novel antiviral drugs.

Most of the progress in hepatitis B virus research are based on infection studies performed with the two most used HBV-related animal viruses: DHBV, which infects Peking ducks (Mason 1980) and WHV (Summers 1978), which infects the Eastern American woodchuck (*Marmota monax*).

One of the major advantages of the DHBV model is that domestic Peking ducks can be used under normal laboratory conditions and DHBV-permissive primary hepatocytes from ducklings or embryos are easily accessible. Furthermore, ducks show very high infectivity rates *in vivo* (Jilbert 1996) with high levels of DHBV replication and antigen expression. However, in contrast to mammalian hepadnaviruses, DHBV infection is cleared within a few days post-infection if the virus is not transmitted vertically. The DHBV genome is also smaller than that of the mammalian hepadnaviruses and shares little primary nucleotide sequence homology (40%) with HBV. Furthermore, DHBV infection is usually not associated with liver disease and development of hepatocellular carcinoma (HCC). Nevertheless, the duck model was widely used in preclinical trials (Zimmerman 2008, Reaiche 2010, Chayama 2011) and has contributed substantially to elucidate the hepadnaviral replication scheme (Mason 1982, Summers 1988, Delmas 2002).

*In vitro* and *in vivo* studies with woodchuck hepatitis B virus (WHV) have been fundamental in the preclinical evaluation of antiviral drugs now in use for treatment of HBV infection (Moraleta 1997, Tennant 1998, Mason 1998, Block 1998, Dandri 2000, Korba 2004, Menne 2005). This is due to the fact that WHV is more similar to HBV in terms of genomic organization than the avian hepadnaviruses. Experimental infection of newborn woodchucks almost invariably leads to chronic

infection, whereas most animals infected at older ages develop acute hepatitis that results in an efficient immune response leading to viral clearance. Since acute and chronic WHV infections in woodchucks show serological profiles similar to those of HBV infection in humans, the woodchuck system has provided important information about factors involved in the establishment of virus infection, replication and viral persistence (Lu 2001). Virtually all WHV chronic carrier woodchucks succumb to HCC 2-4 years post infection. Like in human HCC, regenerative hepatocellular nodules and hepatocellular adenomas are characteristically observed in WHV-infected woodchuck livers (Korba 2004). Proto-oncogene activation by WHV DNA integration has been observed frequently and is thought to play an important role in driving hepatocarcinogenesis in woodchucks, often activating a member of the myc family by various mechanisms (Tennant 2004). Viral integration is commonly found in woodchucks even after resolution of transient infection with WHV (Summers 2003), while its frequency increases dramatically in chronically infected animals (Mason 2005). Interestingly, WHV viral integration was used as a genetic marker to follow the fate of infected hepatocytes during resolution of transient infection in woodchucks (Summers 2003) and to estimate the amount of cell turnover occurring in the course of chronic infection (Mason 2005). Experimental infection studies in woodchucks also demonstrated that WHV mutants that lacked the X gene were unable or severely impaired to replicate *in vivo* (Chen 1993, Zoulim 1994, Zhang 2001). The woodchuck model of viral-induced HCC has been used to test chemoprevention of HCC using long-term antiviral nucleoside therapy and for the development of new imaging agents for the detection of hepatic neoplasms by ultrasound and magnetic resonance imaging (Tennant 2004). One main difference between human and rodent hepatitis B resides in the absence of associated cirrhosis in woodchuck and squirrel livers, even after prolonged viral infection (Buendia 1998). It is possible that the rapid onset of hepatocyte proliferation following liver damage in rodents does account for this discrepancy. In general, despite important advances achieved in understanding the pathogenesis of WHV infection, one general disadvantage for using woodchucks is that they are genetically heterogeneous animals, difficult to breed in captivity and to handle in a laboratory setting.

Although HBV infects humans exclusively, it can be used to infect chimpanzees experimentally and, to a certain extent, *tupaia*, the Asian tree shrew (Baumert 2005). Chimpanzees were the first animals found to be susceptible to HBV infection (Barker 1973) and play an important role in the development of vaccines and in the evaluation of the efficacy of therapeutic antibodies (Ogata 1999, Dagan 2003). Though chimpanzees are not prone to develop chronic liver disease (Gagneux 2004), they provide an ideal model for the analysis of early immunological events of HBV acute infection and pathogenesis (Guidotti 1999). Infection experiments with chimpanzees showed that the majority of viral DNA is eliminated from the liver by non-cytolytic mechanisms that precedes the peak of T cell infiltration (Guidotti 1999). T cell depletion studies in chimpanzees also indicate that the absence of CD8-positive cells greatly delay the onset of viral clearance (Thimme 2003). Chimpanzees have been used for preclinical testing of preventive and therapeutic vaccines (Will 1982, Guidotti 1999, Iwarson 1985, Kim 2008, Murray 2005). Nonetheless, the large size, the strong ethical constraints and the high costs of chimpanzees severely limit their use for research purposes.

The tree shrew species *Tupaia belangeri* has been analyzed for the study of HBV infection both *in vitro* and *in vivo*, taking advantage of the adaptability of these non-rodent mammals to the laboratory environment (Baumert 2005, von Weizsacker 2004). Inoculation of tree shrews with HBV-positive human serum was shown to result in viral DNA replication in their livers, HBsAg secretion into the serum, and production of antibodies to HBsAg and HBeAg (Walter 1996). Although experimental infection of tree shrew with HBV infectious serum is not highly efficient, productive HBV infection was successfully passed through five generations of tree shrews and was specifically blocked by immunization with hepatitis B vaccine (Yan 1996a). Interestingly, the development of hepatocellular carcinoma in tree shrews exposed to hepatitis B virus and/or aflatoxin B1 was reported (Yan 1996b). Whereas experimental infection of tree shrews causes only a mild, transient infection with low viral titers in these animals, primary hepatocytes isolated from *T. belangeri* turned out to be a valuable alternative source of HBV-permissive cells (von Weizsacker 2004). More recently, the woolly monkey hepatitis B virus (WMHV) was isolated from a woolly monkey (*Lagothrix lagotricha*), an endangered new world primate (Lanford 1998). Interestingly, it has been shown that primary *tupaia* hepatocytes are susceptible to infection with WMHBV (Kock 2001, Dandri 2005a), providing a useful and more accessible alternative system for studying the early steps of hepadnaviral infection *in vitro* (Schulze 2011) and *in vivo* (Petersen 2008).

Because of the different limitations encountered using chimpanzees and models based on HBV-related viruses, it is not surprising that recent developments have focused on using the natural target of HBV infection: the human hepatocyte. However, primary human hepatocytes are not easy to handle, cannot be propagated *in vitro* and their susceptibility to HBV infection is generally low and highly variable. Furthermore, cultured cells may respond differently to the infection than hepatocytes in the liver. The generation of mice harboring human chimeric livers offered new possibilities to overcome some of these limitations. Two major models are currently available: the urokinase-type plasminogen activator (uPA) transgenic mouse (Rhim 1994) and the knockout fumarylacetoacetate hydrolase (FAH) mouse (Azuma 2007). In both systems, the absence of adaptive immune responses permits the engraftment of transplanted xenogenic hepatocytes, while the presence of transgene-induced hepatocyte damage creates the space and the regenerative stimulus necessary for the transplanted cells to repopulate the mouse liver. Both models permit the establishment of HBV infection, which can then persist for the life-span of the chimeric mouse (Dandri 2001, Bissig 2010). While mouse hepatocytes do not support HBV infection, human chimeric mice can be efficiently infected by injecting infectious serum derived from either patients or chimeric mice. Furthermore, genetically engineered viruses created in cell culture can be used to investigate phenotype and *in vivo* fitness of distinct HBV genotypes and variants (Tsuge 2005). Within the mouse liver human hepatocytes maintain a functional innate immune system and respond to stimuli induced by exogenously applied human IFN  $\alpha$ . The lack of an adaptive immune system and the undetectable responsiveness of mouse liver cells to human IFN  $\alpha$  make the model ideal to exploit the capacities of HBV to interfere with pathways of the innate antiviral response in human hepatocytes (Lutgehetmann 2011). Chimeric mice can be superinfected or simultaneously infected with different human hepatotropic viruses to investigate the

mechanisms of virus interference and response to antiviral treatment in the setting of coinfection (Hiraga 2009).

## References

- Addison WR, Walters KA, Wong WW, et al. Half-life of the duck hepatitis B virus covalently closed circular DNA pool in vivo following inhibition of viral replication. *J Virol* 2002;76:6356-63. ([Abstract](#))
- Azuma H, Paulk N, Ranade A, et al. Robust expansion of human hepatocytes in Fah<sup>-/-</sup>/Rag2<sup>-/-</sup>/Il2rg<sup>-/-</sup> mice. *Nat Biotechnol* 2007;25:903-10. ([Abstract](#))
- Barker LF, Chisari FV, McGrath PP, et al. Transmission of type B viral hepatitis to chimpanzees. *J Infect Dis* 1973;127(6):648-62. ([Abstract](#))
- Bartenschlager R, Schaller H. Hepadnaviral assembly is initiated by polymerase binding to the encapsidation signal in the viral RNA genome. *Embo J* 1992;11:3413-20. ([Abstract](#))
- Baumert TF, Yang C, Schurmann P, et al. Hepatitis B virus mutations associated with fulminant hepatitis induce apoptosis in primary Tupaia hepatocytes. *Hepatology* 2005;41(2):247-56. ([Abstract](#))
- Beck J, Nassal M. Hepatitis B virus replication. *World J Gastroenterol* 2007;13:48-64. ([Abstract](#))
- Belloni L, Pollicino T, De Nicola F, et al. Nuclear HBx binds the HBV minichromosome and modifies the epigenetic regulation of cccDNA function. *Proc Natl Acad Sci U S A* 2009;106:19975-9. ([Abstract](#))
- Bissig KD, Wieland SF, Tran P, et al. Human liver chimeric mice provide a model for hepatitis B and C virus infection and treatment. *J Clin Invest* 2010;120:924-30. ([Abstract](#))
- Block TM, Guo H, Guo JT. Molecular virology of hepatitis B virus for clinicians. *Clin Liver Dis* 2007;11:685-706. ([Abstract](#))
- Block TM, Lu X, Mehta AS, et al. Treatment of chronic hepadnavirus infection in a woodchuck animal model with an inhibitor of protein folding and trafficking. *Nat Med* 1998;4:610-4. ([Abstract](#))
- Bock CT, Schranz P, Schroder CH, Zentgraf H. Hepatitis B virus genome is organized into nucleosomes in the nucleus of the infected cell. *Virus Genes* 1994;8:215-29. ([Abstract](#))
- Bock CT, Schwinn S, Locarnini S, et al. Structural organization of the hepatitis B virus minichromosome. *J Mol Biol* 2001;307:183-96. ([Abstract](#))
- Bouchard MJ, Schneider RJ. The enigmatic X gene of hepatitis B virus. *J Virol* 2004;78:12725-34. ([Abstract](#))
- Bouchard MJ, Wang LH, Schneider RJ. Calcium signaling by HBx protein in hepatitis B virus DNA replication. *Science* 2001;294:2376-8. ([Abstract](#))
- Brechot C. Pathogenesis of hepatitis B virus-related hepatocellular carcinoma: old and new paradigms. *Gastroenterology* 2004;127(5 Suppl 1):S56-61.
- Bruss V. Hepatitis B virus morphogenesis. *World J Gastroenterol* 2007;13:65-73. ([Abstract](#))
- Buendia MA. Hepatitis B viruses and cancerogenesis. *Biomed Pharma-cother* 1998;52:34-43. ([Abstract](#))
- Chang JJ, Lewin SR. Immunopathogenesis of hepatitis B virus infection. *Immunol Cell Biol* 2007;85:16-23. ([Abstract](#))
- Chayama K, Hayes CN, Hiraga N, Abe H, Tsuge M, Imamura M. Animal model for study of human hepatitis viruses. *J Gastroenterol Hepatol* 2011;26:13-8.
- Chen HS, Kaneko S, Girones R, et al. The woodchuck hepatitis virus X gene is important for establishment of virus infection in woodchucks. *J Virol* 1993;67:1218-26. ([Abstract](#))
- Chen M, Sallberg M, Hughes J, et al. Immune tolerance split between hepatitis B virus precore and core proteins. *J Virol* 2005;79:3016-27. ([Abstract](#))
- Chisari FV, Isogawa M, Wieland SF. Pathogenesis of hepatitis B virus infection. *Pathol Biol (Paris)*;58:258-66. ([Abstract](#))
- Dagan S, Eren R. Therapeutic antibodies against viral hepatitis. *Curr Opin Mol Ther* 2003;5:148-55. ([Abstract](#))
- Dandri M, Burda MR, Burkle A, et al. Increase in de novo HBV DNA integrations in response to oxidative DNA damage or inhibition of poly(ADP-ribosyl)ation. *Hepatology* 2002;35:217-23. ([Abstract](#))
- Dandri M, Burda MR, Torok E, et al. Repopulation of mouse liver with human hepatocytes and in vivo infection with hepatitis B virus. *Hepatology* 2001;33:981-8. ([Abstract](#))

- Dandri M, Burda MR, Will H, Petersen J. Increased hepatocyte turnover and inhibition of woodchuck hepatitis B virus replication by adefovir in vitro do not lead to reduction of the closed circular DNA. *Hepatology* 2000;32:139-46. ([Abstract](#))
- Dandri M, Burda MR, Zuckerman DM, et al. Chronic infection with hepatitis B viruses and antiviral drug evaluation in uPA mice after liver repopulation with tupaia hepatocytes. *J Hepatol* 2005;42:54-60. ([Abstract](#))
- Dandri M, Petersen J. Chimeric Mouse Model of Hepatitis B Virus infection. *J Hepatol* 2011. ([Abstract](#))
- Dandri M, Petersen J. Hepatitis B virus cccDNA clearance: killing for curing? *Hepatology* 2005;42:1453-5. ([Abstract](#))
- Dandri M, Schirmacher P, Rogler CE. Woodchuck hepatitis virus X protein is present in chronically infected woodchuck liver and woodchuck hepatocellular carcinomas which are permissive for viral replication. *J Virol* 1996;70:5246-54. ([Abstract](#))
- Dandri M, Volz TK, Lutgehetmann M, Petersen J. Animal models for the study of HBV replication and its variants. *J Clin Virol* 2005;34 Suppl 1:S54-62. ([Abstract](#))
- Daub H, Blencke S, Habenberger P, et al. Identification of SRPK1 and SRPK2 as the major cellular protein kinases phosphorylating hepatitis B virus core protein. *J Virol* 2002;76:8124-37. ([Abstract](#))
- Delmas J, Schorr O, Jamard C, et al. Inhibitory effect of adefovir on viral DNA synthesis and covalently closed circular DNA formation in duck hepatitis B virus-infected hepatocytes in vivo and in vitro. *Antimicrob Agents Chemother* 2002;46:425-33. ([Abstract](#))
- Engelke M, Mills K, Seitz S, et al. Characterization of a hepatitis B and hepatitis delta virus receptor binding site. *Hepatology* 2006;43:750-60. ([Abstract](#))
- Fung SK, Lok AS. Hepatitis B virus genotypes: do they play a role in the outcome of HBV infection? *Hepatology* 2004;40:790-2. ([Abstract](#))
- Funk A, Mhamdi M, Will H, Sirma H. Avian hepatitis B viruses: molecular and cellular biology, phylogenesis, and host tropism. *World J Gastroenterol* 2007;13:91-103. ([Abstract](#))
- Gagneux P, Muchmore EA. The chimpanzee model: contributions and considerations for studies of hepatitis B virus. *Methods Mol Med* 2004;96:289-318. ([Abstract](#))
- Glebe D, Urban S, Knoop EV, et al. Mapping of the hepatitis B virus attachment site by use of infection-inhibiting preS1 lipopeptides and tupaia hepatocytes. *Gastroenterology* 2005;129:234-45. ([Abstract](#))
- Glebe D, Urban S. Viral and cellular determinants involved in hepadnaviral entry. *World J Gastroenterol* 2007;13:22-38. ([Abstract](#))
- Gripon P, Cannie I, Urban S. Efficient inhibition of hepatitis B virus infection by acylated peptides derived from the large viral surface protein. *J Virol* 2005;79:1613-22. ([Abstract](#))
- Gripon P, Rumin S, Urban S, et al. Infection of a human hepatoma cell line by hepatitis B virus. *Proc Natl Acad Sci USA* 2002;99:15655-60. ([Abstract](#))
- Guidotti LG, Rochford R, Chung J, Shapiro M, Purcell R, Chisari FV. Viral clearance without destruction of infected cells during acute HBV infection. *Science* 1999;284:825-9. ([Abstract](#))
- Guirgis BS, Abbas RO, Azzazy HM. Hepatitis B virus genotyping: current methods and clinical implications. *Int J Infect Dis* 2010;14:e941-53. ([Abstract](#))
- Hadziyannis SJ, Papatheodoridis GV. Hepatitis B e antigen-negative chronic hepatitis B: natural history and treatment. *Semin Liver Dis* 2006;26:130-41. ([Abstract](#))
- Harrison TJ. Hepatitis B virus: molecular virology and common mutants. *Semin Liver Dis* 2006;26:87-96. ([Abstract](#))
- Hiraga N, Imamura M, Hatakeyama T, et al. Absence of viral interference and different susceptibility to interferon between hepatitis B virus and hepatitis C virus in human hepatocyte chimeric mice. *J Hepatol* 2009;51:1046-54. ([Abstract](#))
- Iavarone M, Trabut JB, Delpuech O, et al. Characterisation of hepatitis B virus X protein mutants in tumour and non-tumour liver cells using laser capture microdissection. *J Hepatol* 2003;39:253-61. ([Abstract](#))
- Iwarson S, Tabor E, Thomas HC, et al. Neutralization of hepatitis B virus infectivity by a murine monoclonal antibody: an experimental study in the chimpanzee. *J Med Virol* 1985;16:89-96. ([Abstract](#))
- Jilbert AR, Miller DS, Scougall CA, Turnbull H, Burrell CJ. Kinetics of duck hepatitis B virus infection following low dose virus inoculation: one virus DNA genome is infectious in neonatal ducks. *Virology* 1996;226:338-45. ([Abstract](#))

- Kann M, Gerlich WH. Effect of core protein phosphorylation by protein kinase C on encapsidation of RNA within core particles of hepatitis B virus. *J Virol* 1994;68:7993-8000. ([Abstract](#))
- Kann M, Schmitz A, Rabe B. Intracellular transport of hepatitis B virus. *World J Gastroenterol* 2007;13:39-47. ([Abstract](#))
- Kann M, Sodeik B, Vlachou A, Gerlich WH, Helenius A. Phosphorylation-dependent binding of hepatitis B virus core particles to the nuclear pore complex. *J Cell Biol* 1999;145:45-55. ([Abstract](#))
- Kekule AS, Lauer U, Weiss L, Lubber B, Hofschneider PH. Hepatitis B virus transactivator HBx uses a tumour promoter signalling pathway. *Nature* 1993;361:742-5. ([Abstract](#))
- Kim CM, Koike K, Saito I, Miyamura T, Jay G. HBx gene of hepatitis B virus induces liver cancer in transgenic mice. *Nature* 1991;351:317-20. ([Abstract](#))
- Kim SH, Shin YW, Hong KW, et al. Neutralization of hepatitis B virus (HBV) by human monoclonal antibody against HBV surface antigen (HBsAg) in chimpanzees. *Antiviral Res* 2008;79:188-91. ([Abstract](#))
- Kock J, Nassal M, MacNelly S, Baumert TF, Blum HE, von Weizsacker F. Efficient infection of primary tupaia hepatocytes with purified human and woolly monkey hepatitis B virus. *J Virol* 2001;75:5084-9. ([Abstract](#))
- Kock J, Rosler C, Zhang JJ, Blum HE, Nassal M, Thoma C. Generation of covalently closed circular DNA of hepatitis B viruses via intracellular recycling is regulated in a virus specific manner. *PLoS Pathog* 2010;6:e1001082. ([Abstract](#))
- Korba BE, Cote PJ, Menne S, et al. Clevudine therapy with vaccine inhibits progression of chronic hepatitis and delays onset of hepatocellular carcinoma in chronic woodchuck hepatitis virus infection. *Antivir Ther* 2004;9:937-52. ([Abstract](#))
- Korba BE, Cote PJ, Wells FV, et al. Natural history of woodchuck hepatitis virus infections during the course of experimental viral infection: molecular virologic features of the liver and lymphoid tissues. *J Virol* 1989;63:1360-70. ([Abstract](#))
- Lanford RE, Chavez D, Brasky KM, Burns RB, Rico-Hesse R. Isolation of a hepadnavirus from the woolly monkey, a New World primate. *Proc Natl Acad Sci U S A* 1998;95:5757-61. ([Abstract](#))
- Lang T, Lo C, Skinner N, Locarnini S, Visvanathan K, Mansell A. The hepatitis B e antigen (HBeAg) targets and suppresses activation of the toll-like receptor signaling pathway. *J Hepatol* 2011;55:762-9. ([Abstract](#))
- Laras A, Koskinas J, Dimou E, Kostamena A, Hadziyannis SJ. Intrahepatic levels and replicative activity of covalently closed circular hepatitis B virus DNA in chronically infected patients. *Hepatology* 2006;44:694-702. ([Abstract](#))
- Lee JY, Locarnini S. Hepatitis B virus: pathogenesis, viral intermediates, and viral replication. *Clin Liver Dis* 2004;8:301-20. ([Abstract](#))
- Lentz TB, Loeb DD. Roles of the envelope proteins in the amplification of covalently closed circular DNA and completion of synthesis of the plus-strand DNA in hepatitis B virus. *J Virol* 2011;85:11916-27. ([Abstract](#))
- Levrero M, Pollicino T, Petersen J, Belloni L, Raimondo G, Dandri M. Control of cccDNA function in hepatitis B virus infection. *J Hepatol* 2009;51:581-92. ([Abstract](#))
- Liaw YF, Brunetto MR, Hadziyannis S. The natural history of chronic HBV infection and geographical differences. *Antivir Ther* 2010;15 Suppl 3:25-33. ([Abstract](#))
- Lok AS. Prevention of hepatitis B virus-related hepatocellular carcinoma. *Gastroenterology* 2004;127(5 Suppl 1):S303-9.
- Lu M, Roggendorf M. Evaluation of new approaches to prophylactic and therapeutic vaccinations against hepatitis B viruses in the woodchuck model. *Intervirology* 2001;44:124-31. ([Abstract](#))
- Lucifora J, Arzberger S, Durantel D, et al. Hepatitis B virus X protein is essential to initiate and maintain virus replication after infection. *J Hepatol* 2011;55:996-1003. ([Abstract](#))
- Lupberger J, Hildt E. Hepatitis B virus-induced oncogenesis. *World J Gastroenterol* 2007;13:74-81. ([Abstract](#))
- Lutgehetmann M, Bornscheuer T, Volz T, et al. Hepatitis B Virus Limits Response of Human Hepatocytes to Interferon-alpha in Chimeric Mice. *Gastroenterology* 2011. ([Abstract](#))
- Lutgehetmann M, Mancke LV, Volz T, et al. Human chimeric uPA mouse model to study hepatitis B and D virus interactions and preclinical drug evaluation. *Hepatology* 2011. ([Abstract](#))



- Lutgehetmann M, Volz T, Kopke A, et al. In vivo proliferation of hepadnavirus-infected hepatocytes induces loss of covalently closed circular DNA in mice. *Hepatology* 2010;52:16-24. ([Abstract](#))
- Lutgehetmann M, Volz T, Quaas A, et al. Sequential combination therapy leads to biochemical and histological improvement despite low ongoing intrahepatic hepatitis B virus replication. *Antivir Ther* 2008;13:57-66. ([Abstract](#))
- Lutwick LI, Robinson WS. DNA synthesized in the hepatitis B Dane particle DNA polymerase reaction. *J Virol* 1977;21:96-104. ([Abstract](#))
- Mason WS, Aldrich C, Summers J, Taylor JM. Asymmetric replication of duck hepatitis B virus DNA in liver cells: Free minus-strand DNA. *Proc Natl Acad Sci U S A* 1982;79:3997-4001. ([Abstract](#))
- Mason WS, Cullen J, Moraleda G, et al. Lamivudine therapy of WHV-infected woodchucks. *Virology* 1998;245:18-32. ([Abstract](#))
- Mason WS, Jilbert AR, Summers J. Clonal expansion of hepatocytes during chronic woodchuck hepatitis virus infection. *Proc Natl Acad Sci U S A* 2005;102:1139-44. ([Abstract](#))
- Mason WS, Seal G, Summers J. Virus of Pekin ducks with structural and biological relatedness to human hepatitis B virus. *J Virol* 1980;36:829-36. ([Abstract](#))
- McMahon BJ. The natural history of chronic hepatitis B virus infection. *Hepatology* 2009;49(5 Suppl):S45-55.
- Melegari M, Wolf SK, Schneider RJ. Hepatitis B virus DNA replication is coordinated by core protein serine phosphorylation and HBx expression. *J Virol* 2005;79:9810-20. ([Abstract](#))
- Menne S, Cote PJ, Korba BE, et al. Antiviral effect of oral administration of tenofovir disoproxil fumarate in woodchucks with chronic woodchuck hepatitis virus infection. *Antimicrob Agents Chemother* 2005;49:2720-8.
- Moraleda G, Saputelli J, Aldrich CE, Averett D, Condreay L, Mason WS. Lack of effect of antiviral therapy in nondividing hepatocyte cultures on the closed circular DNA of woodchuck hepatitis virus. *J Virol* 1997;71:9392-9. ([Abstract](#))
- Murray JM, Wieland SF, Purcell RH, Chisari FV. Dynamics of hepatitis B virus clearance in chimpanzees. *Proc Natl Acad Sci U S A* 2005;102:17780-5. ([Abstract](#))
- Nassal M. Hepatitis B viruses: reverse transcription a different way. *Virus Res* 2008;134:235-49. ([Abstract](#))
- Newbold JE, Xin H, Tencza M, et al. The covalently closed duplex form of the hepadnavirus genome exists in situ as a heterogeneous population of viral minichromosomes. *J Virol* 1995;69:3350-7. ([Abstract](#))
- Ogata N, Cote PJ, Zanetti AR, et al. Licensed recombinant hepatitis B vaccines protect chimpanzees against infection with the prototype surface gene mutant of hepatitis B virus. *Hepatology* 1999;30:779-86. ([Abstract](#))
- Park IY, Sohn BH, Yu E, et al. Aberrant epigenetic modifications in hepatocarcinogenesis induced by hepatitis B virus X protein. *Gastroenterology* 2007;132:1476-94. ([Abstract](#))
- Petersen J, Dandri M, Gupta S, Rogler CE. Liver repopulation with xenogenic hepatocytes in B and T cell-deficient mice leads to chronic hepadnavirus infection and clonal growth of hepatocellular carcinoma. *Proc Natl Acad Sci U S A* 1998;95:310-5. ([Abstract](#))
- Petersen J, Dandri M, Mier W, et al. Prevention of hepatitis B virus infection in vivo by entry inhibitors derived from the large envelope protein. *Nat Biotechnol* 2008;26(3):335-41. ([Abstract](#))
- Pollicino T, Saitta C, Raimondo G. Hepatocellular carcinoma: the point of view of the hepatitis B virus. *Carcinogenesis* 2011;32:1122-32. ([Abstract](#))
- Porterfield JZ, Dhason MS, Loeb DD, Nassal M, Stray SJ, Zlotnick A. Full-length hepatitis B virus core protein packages viral and heterologous RNA with similarly high levels of cooperativity. *J Virol* 2010;84:7174-84. ([Abstract](#))
- Pujol FH, Navas MC, Hainaut P, Chemin I. Worldwide genetic diversity of HBV genotypes and risk of hepatocellular carcinoma. *Cancer Lett* 2009;286:80-8. ([Abstract](#))
- Pult I, Netter HJ, Bruns M, et al. Identification and analysis of a new hepadnavirus in white storks. *Virology* 2001;289:114-28. ([Abstract](#))
- Quasdorff M, Hosel M, Odenthal M, et al. A concerted action of HNF4alpha and HNF1alpha links hepatitis B virus replication to hepatocyte differentiation. *Cell Microbiol* 2008;10:1478-90. ([Abstract](#))

## 82 Hepatology 2012

- Rabe B, Glebe D, Kann M. Lipid-mediated introduction of hepatitis B virus capsids into nonsusceptible cells allows highly efficient replication and facilitates the study of early infection events. *J Virol* 2006;80:5465-73. ([Abstract](#))
- Reaiche GY, Le Mire MF, Mason WS, Jilbert AR. The persistence in the liver of residual duck hepatitis B virus covalently closed circular DNA is not dependent upon new viral DNA synthesis. *Virology* 2010;406:286-92. ([Abstract](#))
- Rehermann B, Ferrari C, Pasquinelli C, Chisari FV. The hepatitis B virus persists for decades after patients' recovery from acute viral hepatitis despite active maintenance of a cytotoxic T-lymphocyte response. *Nat Med* 1996;2:1104-8. ([Abstract](#))
- Rhim JA, Sandgren EP, Degen JL, Palmiter RD, Brinster RL. Replacement of diseased mouse liver by hepatic cell transplantation. *Science* 1994;263:1149-52. ([Abstract](#))
- Roggendorf M, Schulte I, Xu Y, Lu M. Therapeutic vaccination in chronic hepatitis B: preclinical studies in the woodchuck model. *J Viral Hepat* 2007;14 Suppl 1:51-7. ([Abstract](#))
- Roggendorf M, Tolle TK. The woodchuck: an animal model for hepatitis B virus infection in man. *Intervirolgy* 1995;38:100-12. ([Abstract](#))
- Schaefer S. Hepatitis B virus taxonomy and hepatitis B virus genotypes. *World J Gastroenterol* 2007;13:14-21. ([Abstract](#))
- Schildgen O, Roggendorf M, Lu M. Identification of a glycosylation site in the woodchuck hepatitis virus preS2 protein and its role in protein trafficking. *J Gen Virol* 2004;85:787-93. ([Abstract](#))
- Schmitt S, Glebe D, Tolle TK, et al. Structure of pre-S2 N- and O-linked glycans in surface proteins from different genotypes of hepatitis B virus. *J Gen Virol* 2004;85:2045-53. ([Abstract](#))
- Schmitz A, Schwarz A, Foss M, et al. Nucleoporin 153 arrests the nuclear import of hepatitis B virus capsids in the nuclear basket. *PLoS Pathog* 2010;6:e1000741.
- Schultz U, Grgacic E, Nassal M. Duck hepatitis B virus: an invaluable model system for HBV infection. *Adv Virus Res* 2004;63:1-70. ([Abstract](#))
- Schulze A, Gripon P, Urban S. Hepatitis B virus infection initiates with a large surface protein-dependent binding to heparan sulfate proteoglycans. *Hepatology* 2007;46:1759-68. ([Abstract](#))
- Schulze A, Mills K, Weiss TS, Urban S. Hepatocyte polarization is essential for the productive entry of the hepatitis B virus. *Hepatology* 2011. ([Abstract](#))
- Schulze A, Schieck A, Ni Y, Mier W, Urban S. Fine mapping of pre-S sequence requirements for hepatitis B virus large envelope protein-mediated receptor interaction. *J Virol* 2010;84:1989-2000. ([Abstract](#))
- Seeger C, Ganem D, Varmus HE. Biochemical and genetic evidence for the hepatitis B virus replication strategy. *Science* 1986;232:477-84. ([Abstract](#))
- Seeger C, Mason WS. Hepatitis B virus biology. *Microbiol Mol Biol Rev* 2000;64:51-68. ([Abstract](#))
- Shepard CW, Simard EP, Finelli L, Fiore AE, Bell BP. Hepatitis B virus infection: epidemiology and vaccination. *Epidemiol Rev* 2006;28:112-25. ([Abstract](#))
- Slagle BL, Lee TH, Medina D, Finegold MJ, Butel JS. Increased sensitivity to the hepatocarcinogen diethylnitrosamine in transgenic mice carrying the hepatitis B virus X gene. *Mol Carcinog* 1996;15:261-9. ([Abstract](#))
- Sprengel R, Kaleta EF, Will H. Isolation and characterization of a hepatitis B virus endemic in herons. *J Virol* 1988;62:3832-9. ([Abstract](#))
- Summers J, Jilbert AR, Yang W, et al. Hepatocyte turnover during resolution of a transient hepadnaviral infection. *Proc Natl Acad Sci U S A* 2003;100:11652-9. ([Abstract](#))
- Summers J, Mason WS. Residual integrated viral DNA after hepadnavirus clearance by nucleoside analog therapy. *Proc Natl Acad Sci U S A* 2004;101:638-40. ([Abstract](#))
- Summers J, Smith PM, Huang MJ, Yu MS. Morphogenetic and regulatory effects of mutations in the envelope proteins of an avian hepadnavirus. *J Virol* 1991;65:1310-7. ([Abstract](#))
- Summers J, Smolec JM, Snyder R. A virus similar to human hepatitis B virus associated with hepatitis and hepatoma in woodchucks. *Proc Natl Acad Sci U S A* 1978;75:4533-7. ([Abstract](#))
- Summers J. The replication cycle of hepatitis B viruses. *Cancer* 1988;61:1957-62. ([Abstract](#))
- Tennant BC, Baldwin BH, Graham LA, et al. Antiviral activity and toxicity of fialuridine in the woodchuck model of hepatitis B virus infection. *Hepatology* 1998;28:179-91. ([Abstract](#))
- Tennant BC, Toshkov IA, Peek SF, et al. Hepatocellular carcinoma in the woodchuck model of hepatitis B virus infection. *Gastroenterology* 2004;127(5 Suppl 1):S283-93. ([Abstract](#))

- Thermet A, Buronfosse T, Werle-Lapostolle B, et al. DNA vaccination in combination or not with lamivudine treatment breaks humoral immune tolerance and enhances cccDNA clearance in the duck model of chronic hepatitis B virus infection. *J Gen Virol* 2008;89:1192-201.
- Thimme R, Wieland S, Steiger C, et al. CD8(+) T cells mediate viral clearance and disease pathogenesis during acute hepatitis B virus infection. *J Virol* 2003;77:68-76. (Abstract)
- Tsuge M, Hiraga N, Akiyama R, et al. HBx protein is indispensable for development of viraemia in human hepatocyte chimeric mice. *J Gen Virol* 2010;91:1854-64. (Abstract)
- Tsuge M, Hiraga N, Takaishi H, et al. Infection of human hepatocyte chimeric mouse with genetically engineered hepatitis B virus. *Hepatology* 2005;42:1046-54. (Abstract)
- Urban S, Schulze A, Dandri M, Petersen J. The replication cycle of hepatitis B virus. *J Hepatol* 2010;52:282-4. (Abstract)
- Visvanathan K, Lewin SR. Immunopathogenesis: role of innate and adaptive immune responses. *Semin Liver Dis* 2006;26:104-15. (Abstract)
- Volz T, Lutgehetmann M, Wachtler P, et al. Impaired Intrahepatic Hepatitis B Virus Productivity Contributes to Low Viremia in Most HBeAg-Negative Patients. *Gastroenterology* 2007;133:843-52. (Abstract)
- von Weizsacker F, Kock J, MacNelly S, Ren S, Blum HE, Nassal M. The tupaia model for the study of hepatitis B virus: direct infection and HBV genome transduction of primary tupaia hepatocytes. *Methods Mol Med* 2004;96:153-61. (Abstract)
- Walter E, Keist R, Niederost B, Pult I, Blum HE. Hepatitis B virus infection of tupaia hepatocytes in vitro and in vivo. *Hepatology* 1996;24:1-5. (Abstract)
- Werle-Lapostolle B, Bowden S, Locarnini S, et al. Persistence of cccDNA during the natural history of chronic hepatitis B and decline during adefovir dipivoxil therapy. *Gastroenterology* 2004;126:1750-8. (Abstract)
- Wieland S, Thimme R, Purcell RH, Chisari FV. Genomic analysis of the host response to hepatitis B virus infection. *Proc Natl Acad Sci U S A* 2004;101:6669-74. (Abstract)
- Will H, Cattaneo R, Koch HG, et al. Cloned HBV DNA causes hepatitis in chimpanzees. *Nature* 1982;299:740-2. (Abstract)
- Wong DK, Yuen MF, Yuan H, et al. Quantitation of covalently closed circular hepatitis B virus DNA in chronic hepatitis B patients. *Hepatology* 2004;40:727-37. (Abstract)
- Wu TT, Coates L, Aldrich CE, Summers J, Mason WS. In hepatocytes infected with duck hepatitis B virus, the template for viral RNA synthesis is amplified by an intracellular pathway. *Virology* 1990;175:255-61. (Abstract)
- Wursthorn K, Lutgehetmann M, Dandri M, et al. Peginterferon alpha-2b plus adefovir induce strong cccDNA decline and HBsAg reduction in patients with chronic hepatitis B. *Hepatology* 2006;44:675-84. (Abstract)
- Yan RQ, Su JJ, Huang DR, Gan YC, Yang C, Huang GH. Human hepatitis B virus and hepatocellular carcinoma. I. Experimental infection of tree shrews with hepatitis B virus. *J Cancer Res Clin Oncol* 1996;122:283-8. (Abstract)
- Yan RQ, Su JJ, Huang DR, Gan YC, Yang C, Huang GH. Human hepatitis B virus and hepatocellular carcinoma. II. Experimental induction of hepatocellular carcinoma in tree shrews exposed to hepatitis B virus and aflatoxin B1. *J Cancer Res Clin Oncol* 1996;122:289-95. (Abstract)
- Yang B, Bouchard MJ. The Hepatitis B Virus X Protein Elevates Cytosolic Calcium Signals by Modulating Mitochondrial Calcium Uptake. *J Virol* 2011. (Abstract)
- Zhang YY, Zhang BH, Theele D, Litwin S, Toll E, Summers J. Single-cell analysis of covalently closed circular DNA copy numbers in a hepadnavirus-infected liver. *Proc Natl Acad Sci U S A* 2003;100:12372-7. (Abstract)
- Zhang Z, Protzer U, Hu Z, Jacob J, Liang TJ. Inhibition of cellular pro-teasome activities enhances hepadnavirus replication in an HBX-dependent manner. *J Virol* 2004;78:4566-72. (Abstract)
- Zhang Z, Torii N, Hu Z, Jacob J, Liang TJ. X-deficient woodchuck hepatitis virus mutants behave like attenuated viruses and induce protective immunity in vivo. *J Clin Invest* 2001;108:1523-31. (Abstract)
- Zimmerman KA, Fischer KP, Joyce MA, Tyrrell DL. Zinc finger proteins designed to specifically target duck hepatitis B virus covalently closed circular DNA inhibit viral transcription in tissue culture. *J Virol* 2008;82:8013-21. (Abstract)
- Zoulim F, Locarnini S. Hepatitis B virus resistance to nucleos(t)ide analogues. *Gastroenterology* 2009;137:1593-608 e1-2. (Abstract)

## 84 Hepatology 2012

- Zoulim F, Saputelli J, Seeger C. Woodchuck hepatitis virus X protein is required for viral infection in vivo. *J Virol* 1994;68:2026-30. ([Abstract](#))
- Zoulim F, Seeger C. Reverse transcription in hepatitis B viruses is primed by a tyrosine residue of the polymerase. *J Virol* 1994;68:6-13. ([Abstract](#))
- Zoulim F. Assessment of treatment efficacy in HBV infection and disease. *J Hepatol* 2006;44 Suppl 1:S95-9. ([Abstract](#))
- Zoulim F. Combination of nucleoside analogues in the treatment of chronic hepatitis B virus infection: lesson from experimental models. *J Antimicrob Chemother* 2005;55:608-11. ([Abstract](#))
- Zoulim F. New insight on hepatitis B virus persistence from the study of intrahepatic viral cccDNA. *J Hepatol* 2005;42:302-8. ([Abstract](#))

## 6. HCV Virology

*Bernd Kupfer*

### History

Hepatitis C virus (HCV) is a major cause of progressive liver disease with approximately 130-170 million people infected worldwide. HCV induces chronic infection in up to 80% of infected individuals. The main complications of HCV infection are severe liver fibrosis and cirrhosis, and 30-50% of individuals with cirrhosis go on to develop hepatocellular carcinoma (Tong 1995, Poynard 1997).

Until 1975, only two hepatitis viruses had been identified, the “infectious hepatitis virus” (hepatitis A virus, HAV) and the “serum hepatitis virus” (hepatitis B virus, HBV). However, other viruses were excluded from being the cause of approximately 65% of post-transfusion hepatitis. Therefore, these hepatitis cases were termed “non-A, non-B hepatitis” (NANBH) (Feinstone 1975). Inoculation of chimpanzees (*Pan troglodytes*) with blood products derived from humans with NANBH hepatitis led to persistent increases of serum alanine aminotransferase (ALT) indicating that an infectious agent was the cause of the disease (Alter 1978, Hollinger 1978). Subsequently, it was demonstrated that the NANBH agent could be inactivated by chloroform (Feinstone 1983). Moreover, it was reported that the infectious agent was able to pass through 80 nm membrane filters (Bradley 1985). Taken together these findings suggested that the NANBH causing agent would be a small virus with a lipid envelope. However, the lack of a suitable cell culture system for cultivation of the NANBH agent and the limited availability of chimpanzees prevented further characterization of the causative agent of NANBH for several years. In 1989, using a newly developed cloning strategy for nucleic acids derived from plasma of NANBH infected chimpanzees the genome of the major causative agent for NANBH was characterized (Choo 1989). cDNA clone 5-1-1 encoded immunological epitopes that interacted with sera from individuals with NANBH (Choo 1989, Kuo 1989). The corresponding infectious virus causing the majority of NANBH was subsequently termed hepatitis C virus (HCV).

## Taxonomy and genotypes

HCV is a small-enveloped virus with one single-stranded positive-sense RNA molecule of approximately 9.6 kb. It is a member of the *Flaviviridae* family. This viral family contains three genera, flavivirus, pestivirus, and hepacivirus. To date, only two members of the hepacivirus genus have been identified, HCV and GB virus B (GBV-B), a virus that had been initially detected together with the then-unclassified virus GB virus A (GBV-A) in a surgeon with active hepatitis (Thiel 2005, Ohba 1996, Simons 1995). However, the natural hosts for GBV-B and GBV-C seem to be monkeys of the *Saguinus* species (tamarins). Analyses of viral sequences and phylogenetic comparisons support HCV's membership in a distinct genus from flavivirus or pestivirus (Choo 1991). The error-prone RNA polymerase of HCV together with the high replication rate of the virus is responsible for the large interpatient genetic diversity of HCV strains. Moreover, the extent of viral diversification of HCV strains within a single HCV-positive individual increases significantly over time, resulting in the development of quasispecies (Bukh 1995).

Comparisons of HCV nucleotide sequences derived from individuals from different geographical regions revealed the presence of six major HCV genotypes with a large number of subtypes within each genotype (Simmonds 2004, Simmonds 2005). Sequence divergence of genotypes and subtypes is 20% and 30%, respectively. HCV strains belonging to the major genotypes 1, 2, 4, and 5 are found in sub-Saharan Africa whereas genotypes 3 and 6 are detected with extremely high diversity in South East Asia. This suggests that these geographical areas could be the origin of the different HCV genotypes. The emergence of different HCV genotypes in North America and Europe and other non-tropical countries appears to represent more recent epidemics introduced from the countries of the original HCV epidemics (Simmonds 2001, Ndjomou 2003). Besides epidemiological aspects, determination of the HCV genotype plays an important role for the initiation of anti-HCV treatment since the response of different genotypes varies significantly with regard to specific antiviral drug regimens, e.g., genotype 1 is most resistant to the current therapy of the combination of pegylated interferon  $\alpha$  and ribavirin (Manns 2001, Fried 2002).

## Viral structure

Structural analyses of HCV virions are very limited since the virus is difficult to cultivate in cell culture systems, a prerequisite for yielding sufficient virions for electron microscopy. Moreover, serum-derived virus particles are associated with serum low-density lipoproteins (Thomssen 1992), which makes it difficult to isolate virions from serum/plasma of infected subjects by centrifugation. Visualization of HCV virus-like particles via electron microscopy succeeded only rarely (Kaito 1994, Shimizu 1996a, Prince 1996) and it was a point of controversy if the detected structures really were HCV virions. Nevertheless, these studies suggest that HCV has a diameter of 55-65 nm confirming size prediction of the NANBH agent by ultra-filtration (Bradley 1985). Various forms of HCV virions appear to exist in the blood of infected individuals: virions bound to very low density lipoproteins (VLDL), virions bound to low density lipoproteins (LDL), virions complexed with immunoglobulins, and free circulating virions (Bradley 1991, Thomssen 1992,

Thomssen 1993, Agnello 1999, Andre 2002). The reasons for the close association of a major portion of circulating virions with LDL and VLDL remain unexplained. One possible explanation is that HCV theoretically enters hepatocytes via the LDL receptor (Agnello 1999, Nahmias 2006). Moreover, it is speculated that the association with LDL and/or VLDL protects the virus against neutralization by HCV-specific antibodies.

The design and optimization of subgenomic and genomic HCV replicons in the human hepatoma cell line Huh7 offered for the first time the possibility to investigate HCV RNA replication in a standardized manner (Lohmann 1999, Ikeda 2002, Blight 2002). However, despite the high level of HCV gene expression, no infectious viral particles are actually produced. Therefore, it cannot be used for structural analysis of free virions.

Infectious HCV particles have been achieved in cell culture by using recombinant systems (Heller 2005, Lindenbach 2005, Wakita 2005, Zhong 2005, Yu 2007). However, even in these *in vitro* systems the limited production of viral particles prevents 3D structural analysis (Yu 2007). It was also shown by cryoelectron microscopy (cryoEM) and negative-stain transmission electron microscopy that HCV virions isolated from cell culture have a spherical shape with a diameter of approximately 50 to 55 nm (Heller 2005, Wakita 2005, Yu 2007) confirming earlier results that measured the size of putative native HCV particles from the serum of infected individuals (Prince 1996). The outer surface of the viral envelope seems to be smooth. Size and morphology are therefore very similar to other members of the *Flaviviridae* family such as the dengue virus and the West Nile virus (Yu 2007). Modifying a baculovirus system (Jeong 2004, Qiao 2004) the same authors were able to produce large quantities of HCV-like particles (HCV-LP) in insect cells (Yu 2007). Analysing the HCV-LPs by cryoEM it was demonstrated that the HCV E1 protein is present in spikes located on the outer surface of the LPs.

Using 3D modeling of the HCV-LPs together with genomic comparison of HCV and well-characterized flaviviruses it is assumed that 90 copies of a block of two heterodimers of HCV proteins E1 and E2 form the outer layer of the virions with a diameter of approximately 50 nm (Yu 2007). This outer layer surrounds the lipid bilayer that contains the viral nucleocapsid consisting of several molecules of the HCV core (C) protein. An inner spherical structure with a diameter of approximately 30-35 nm has been observed (Wakita 2005) suggesting the nucleocapsid that harbours the viral genome (Takahashi 1992).

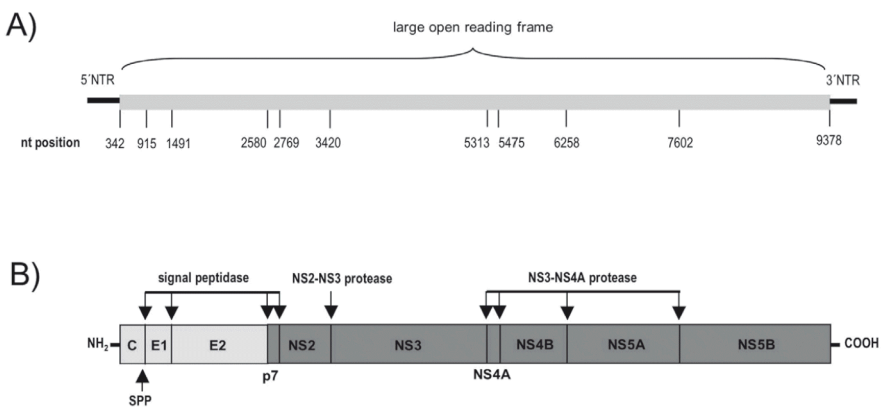
## Genome organization

The genome of the hepatitis C virus consists of one 9.6 kb single-stranded RNA molecule with positive polarity. Similar to other positive-strand RNA viruses, the genomic RNA of hepatitis C virus serves as messenger RNA (mRNA) for the translation of viral proteins. The linear molecule contains a single open reading frame (ORF) coding for a precursor polyprotein of approximately 3000 amino acid residues (Figure 1). During viral replication the polyprotein is cleaved by viral as well as host enzymes into three structural proteins (core, E1, E2) and seven non-structural proteins (p7, NS2, NS3, NS4A, NS4B, NS5A, NS5B). An additional protein (termed F [frameshift] or ARF [alternate reading frame]) is predicted as a result of ribosomal frameshifting during translation within the core region of the

genomic RNA (Xu 2001, Walewski 2001, Varaklioti 2002, Branch 2005). Detection of anti-F protein antibodies in the serum of HCV-positive subjects indicates that the protein is expressed during infection *in vivo* (Walewski 2001, Komurian-Pradel 2004).

The structural genes encoding the viral core protein and the viral envelope proteins E1 and E2 are located at the 5' terminus of the open reading frame followed downstream by the coding regions for the non-structural proteins p7, NS2, NS3, NS4A, NS4B, NS5A, and NS5B (Figure 1). The structural proteins are essential components of the HCV virions, whereas the non-structural proteins are not associated with virions but are involved in RNA replication and virion morphogenesis.

The ORF is flanked by 5' and 3' nontranslated regions (NTR; also called untranslated regions, UTR or noncoding regions, NCR) containing nucleotide sequences relevant for the regulation of viral replication. Both NTRs harbour highly conserved regions compared to the protein encoding regions of the HCV genome. The high grade of conservation of the NTRs makes them candidates i) for improved molecular diagnostics, ii) as targets for antiviral therapeutics, and iii) as targets for an anti-HCV vaccine.



**Figure 1. Genome organization and polyprotein processing.** A) Nucleotide positions correspond to the HCV strain H77 genotype 1a, accession number NC\_004102. nt, nucleotide; NTR, nontranslated region. B) Cleavage sites within the HCV precursor polyprotein for the cellular signal peptidase the signal peptide peptidase (SPP) and the viral proteases NS2-NS3 and NS3-NS4A, respectively.

The 5' NTR is approximately 341 nucleotides long with a complex secondary structure of four distinct domains (I-IV) (Fukushi 1994, Honda 1999). The first 125 nucleotides of the 5' NTR spanning domains I and II have been shown to be essential for viral RNA replication (Friebe 2001, Kim 2002). Domains II-IV build an internal ribosome entry site (IRES) involved in ribosome binding and subsequent cap-independent initiation of translation (Tsukiyama-Kohara 1992, Wang 1993).

The 3' NTR consists of three functionally distinct regions: a variable region, a poly U/UC tract of variable length, and the highly conserved X tail at the 3' terminus of the HCV genome (Tanaka 1995, Kolykhalov 1996, Blight 1997). The



variable region of approximately 40 nucleotides is not essential for RNA replication. However, deletion of this sequence led to significantly decreased replication efficiency (Yanagi 1999, Friebe 2002). The length of the poly U/UC region varies in different HCV strains ranging from 30 to 80 nucleotides (Kolykhalov 1996). The minimal length of that region for active RNA replication has been reported to be 26 homouridine nucleotides in cell culture (Friebe 2002). The highly conserved 98-nucleotide X tail consists of three stem-loops (SL1-SL3) (Tanaka 1996, Ito 1997, Blight 1997) and deletions or nucleotide substitutions within that region are most often lethal (Yanagi 1999, Kolykhalov 2000, Friebe 2002, Yi 2003). Another so-called “kissing-loop” interaction of the 3'X tail SL2 and a complementary portion of the NS5B encoding region has been described (Friebe 2005). This interaction induces a tertiary RNA structure of the HCV genome that is essential for HCV replication in cell culture systems (Friebe 2005, You 2008). Finally, both NTRs appear to work together in a long-range RNA-RNA interaction possibly resulting in temporary genome circularization (Song 2006).

## Genes and proteins

As described above, translation of the HCV polyprotein is initiated through involvement of some domains in NTRs of the genomic HCV RNA. The resulting polyprotein consists of ten proteins that are co-translationally or post-translationally cleaved from the polyprotein. The N-terminal proteins C, E1, E2, and p7 are processed by a cellular signal peptidase (SP) (Hijikata 1991). The resulting immature core protein still contains the E1 signal sequence at its C terminus. Subsequent cleavage of this sequence by a signal peptide peptidase (SPP) leads to the mature core protein (McLauchlan 2002). The non-structural proteins NS2 to NS5B of the HCV polyprotein are processed by two virus-encoded proteases (NS2-NS3 and NS3) with the NS2-NS3 cysteine protease cleaving at the junction of NS2-NS3 (Santolini 1995) and the NS3 serine protease cleaving the remaining functional proteins (Bartenschlager 1993, Eckart 1993, Grakoui 1993a, Tomei 1993).

The positions of viral nucleotide and amino acid residues correspond to the HCV strain H77 genotype 1a, accession number NC\_004102. Some parameters characterizing HCV proteins are summarised in Table 1.

**Core.** The core-encoding sequence starts at codon AUG at nt position 342 of the H77 genome, the start codon for translation of the entire HCV polyprotein. During translation the polyprotein is transferred to the endoplasmic reticulum (ER) where the core protein (aa 191) is excised by a cellular signal peptidase (SP). The C terminus of the resulting core precursor still contains the signal sequence for ER membrane translocation of the E1 ectodomain (aa 174-191). This protein region is further processed by the cellular intramembrane signal peptide peptidase (SPP) leading to removal of the E1 signal peptide sequence (Hüssy 1996, McLauchlan 2002, Weihofen 2002).

The multifunctional core protein has a molecular weight of 21 kilodalton (kd). *In vivo*, the mature core molecules are believed to form homo-multimers located mainly at the ER membrane (Matsumoto 1996). They have a structural function since they form the viral capsid that contains the HCV genome. In addition, the core protein has regulatory functions including particle assembly, viral RNA binding, and regulation of RNA translation (Ait-Goughoulte 2006, Santolini 1994).

Moreover, protein expression analyses indicate that the core protein may be involved in many other cellular reactions such as cell signalling, apoptosis, lipid metabolism, and carcinogenesis (Tellinghuisen 2002). However, these preliminary findings need to be analysed further.

**Table 1. Overview of the size of HCV proteins.\***

Protein	No. of aa	aa position in ref. seq.	MW of protein
Core immature	191	1-191	23 kd
Core mature	174	1-174	21 kd
F-protein or ARF-protein	126-161		~ 16-17 kd
E1	192	192-383	35 kd
E2	363	384-746	70 kd
p7	63	747-809	7 kd
NS2	217	810-1026	21 kd
NS3	631	1027-1657	70 kd
NS4A	54	1658-1711	4 kd
NS4B	261	1712-1972	27 kd
NS5A	448	1973-2420	56 kd
NS5B	591	2421-3011	66 kd

\* aa, amino acid; MW, molecular weight; kd, kilodalton; ref. seq., reference sequence (HCV strain H77; accession number NC\_004102).

**E1 and E2.** Downstream of the core coding region of the HCV RNA genome two envelope glycoproteins are encoded, E1 (gp35, aa 192) and E2 (gp70, aa 363). During translation at the ER both proteins are cleaved from the precursor polyprotein by a cellular SP. Inside the lumen of the ER both polypeptides experience N-linked glycosylation post-translationally (Duvet 2002). Both glycoproteins E1 and E2 harbour 5 and 11 putative N-glycosylation sites, respectively.

E1 and E2 are type I transmembrane proteins with a large hydrophilic ectodomain of approximately 160 and 334 aa and a short transmembrane domain (TMD) of 30 aa. The TMD are responsible for the anchoring of the envelope proteins in the membrane of the ER and ER retention (Cocquerel 1998, Duvet 1998, Cocquerel 1999, Cocquerel 2001). Moreover, the same domains have been reported to contribute to the formation of E1-E2 heterodimers (Op de Beeck 2000). The E1-E2 complex is involved in adsorption of the virus to its putative receptors tetraspanin CD81 and low-density lipoprotein receptor inducing fusion of the viral envelope with the host cell plasma membrane (Agnello 1999, Flint 1999, Wunschmann 2000). However, the precise mechanism of host cell entry is still not understood completely. Several other host factors have been identified to be involved in viral entry. These candidates include the scavenger receptor B type I (Scarselli 2002, Kapadia 2007), the tight junction proteins claudin-1 (Evans 2007) and occludin (Ploss 2009), the C-type lectins L-SIGN and DC-SIGN (Gardner 2003, Lozach 2003, Pöhlmann 2003) and heparan sulfate (Barth 2003).

Two hypervariable regions have been identified within the coding region of E2. These regions termed hypervariable region 1 (HVR1) and 2 (HVR2) differ by up to 80% in their amino acid sequence (Weiner 1991, Kato 2001). The first 27 aa of the E2 ectodomain represent HVR1, while the HVR2 is formed by a stretch of seven

amino acids (position 91-97). The high variability of the HVRs reflects exposure of these domains to HCV-specific antibodies. In fact, E2-HVR1 has been shown to be the most important target for neutralizing antibodies (Farci 1996, Shimizu 1996b). However, the combination of the mutation of the viral genome with the selective pressure of the humoral immune response leads to viral escape via epitope alterations. This makes the development of vaccines that induce neutralizing antibodies challenging.

**The p7 protein.** The small p7 protein (63 aa) is located between the E2 and NS2 regions of the polyprotein precursor. During translation the cellular SP cleaves the E2-p7 as well as the p7-NS2 junction. The functional p7 is a membrane protein localised in the endoplasmic reticulum where it forms an ion channel (Haqshenas 2007, Pavlovic 2003, Griffin 2003). The p7 protein is not essential for RNA replication since replicons lacking the p7 gene replicate efficiently (Lohmann 1999, Blight 2000), however, it has been suggested that p7 plays an essential role for the formation of infectious virions (Sakai 2003, Haqshenas 2007).

**NS2.** The non-structural protein 2 (p21, 217 aa) together with the N-terminal portion of the NS3 protein form the NS2-3 cysteine protease which catalyses cleavage of the polyprotein precursor between NS2 and NS3 (Grakoui 1993b, Santolini 1995). The N-terminus of the functional NS2 arises from the cleavage of the p7-NS2 junction by the cellular SP. Moreover, after cleavage from the NS3 the protease domain of NS2 seems to play an essential role in the early stage of virion morphogenesis (Jones 2007).

**NS3.** The non-structural protein 3 (p70, 631 aa) is cleaved at its N terminus by the NS2-NS3 protease. The N terminus (189 aa) of the NS3 protein has a serine protease activity. However, in order to develop full activity of the protease the NS3 protease domain requires a portion of NS4A (Faila 1994, Bartenschlager 1995, Lin 1995, Tanji 1995, Tomei 1996). NS3 together with the NS4A cofactor are responsible for cleavage of the remaining downstream cleavages of the HCV polyprotein precursor. Since the NS3 protease function is essential for viral infectivity it is a promising target in the design of antiviral treatments.

The C-terminal portion of NS3 (442 aa) has ATPase/helicase activity, i.e., it catalyses the binding and unwinding of the viral RNA genome during viral replication (Jin 1995, Kim 1995). However, recent findings indicate that other non-structural HCV proteins such as the viral polymerase NS5B may interact functionally with the NS3 helicase (Jennings 2008). These interactions need to be investigated further in order to better understand the mechanisms of HCV replication.

**NS4A.** The HCV non-structural protein 4A (p4) is a 54 amino acid polypeptide that acts as a cofactor of the NS3 serine protease (Faila 1994, Bartenschlager 1995, Lin 1995, Tanji 1995, Tomei 1996). Moreover, this small protein is involved in the targeting of NS3 to the endoplasmic reticulum resulting in a significant increase of NS3 stability (Wölk 2000).

**NS4B.** The NS4B (p27) consists of 217 amino acids. It is an integral membrane protein localized in the endoplasmic reticulum. The N-terminal domain of the NS4B has an amphipathic character that targets the protein to the ER. This domain is crucial in HCV replication (Elazar 2004, Gretton 2005) and therefore an interesting target for the development of anti-HCV therapeutics or vaccines. In addition, a nucleotide-binding motif (aa 129-134) has been identified (Einav 2004). Although

the function of NS4B is still unknown, it has been demonstrated that the protein induces a membranous web that may serve as a platform for HCV RNA replication (Egger 2002).

**NS5A.** The NS5A protein (p56; 458 aa) is a membrane-associated phosphoprotein that appears to have multiple functions in viral replication. It is phosphorylated by different cellular protein kinases indicating an essential but still not understood role of NS5A in the HCV replication cycle. In addition, NS5A has been found to be associated with several other cellular proteins (MacDonald 2004) making it difficult to determine the exact functions of the protein. One important property of NS5A is that it contains a domain of 40 amino acids, the so-called IFN- $\alpha$  sensitivity-determining region (ISDR) that plays a significant role in the response to IFN- $\alpha$ -based therapy (Enomoto 1995, Enomoto 1996). An increasing number of mutations within the ISDR showed positive correlation with sustained virological response to IFN- $\alpha$ -based treatment.

**NS5B.** The non-structural protein 5B (p66; 591 aa) represents the RNA-dependent RNA polymerase of HCV (Behrens 1996). The hydrophobic domain (21 aa) at the C terminus of NS5B inserts into the membrane of the endoplasmic reticulum, while the active sites of the polymerase are located in the cytoplasm (Schmidt-Mende 2001).

The cytosolic domains of the viral enzyme form the typical polymerase right-handed structure with “palm”, “fingers”, and “thumb” subdomains (Ago 1999, Bressanelli 1999, Lesburg 1999). In contrast to mammalian DNA and RNA polymerases the fingers and thumb subdomains are connected resulting in a fully enclosed active site for nucleotide triphosphate binding. This unique structure makes the HCV NS5B polymerase an attractive target for the development of antiviral drugs.

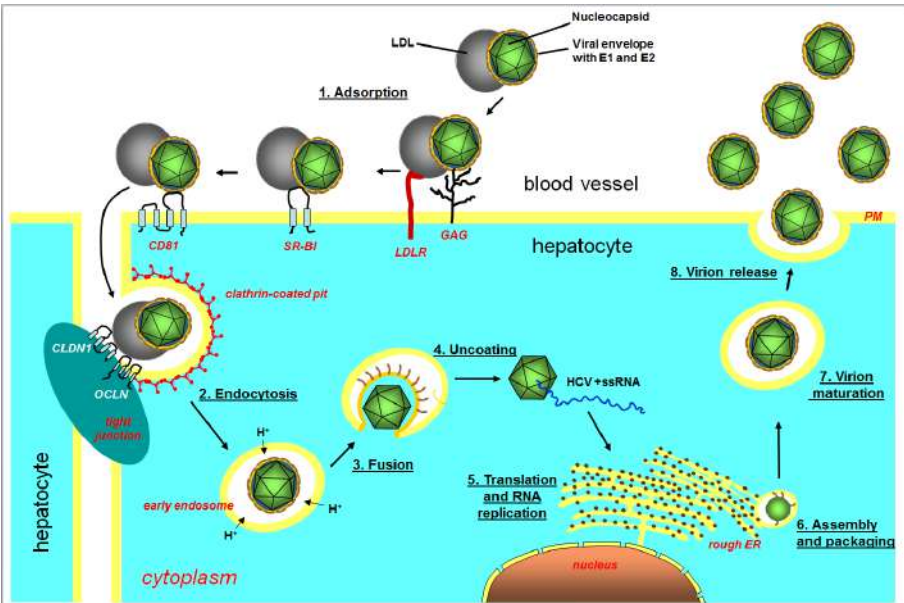
Using the genomic HCV RNA as a template, the NS5B promotes the synthesis of minus-stranded RNA that then serves as a template for the synthesis of genomic positive-stranded RNA by the polymerase.

Similar to other RNA-dependent polymerases, NS5B is an error-prone enzyme that incorporates wrong ribonucleotides at a rate of approximately  $10^{-3}$  per nucleotide per generation. Unlike cellular polymerases, the viral NS5B lacks a proof-reading mechanism leading to the conservation of misincorporated ribonucleotides. These enzyme properties together with the high rate of viral replication promote a pronounced intra-patient as well as inter-patient HCV evolution.

**F protein, ARFP.** In addition to the ten proteins derived from the long HCV ORF, the F (frameshift) or ARF (alternate reading frame) or core+1 protein has been reported (Walewski 2001, Xu 2001, Varaklioti 2002). As the designations indicate the ARFP is the result of a -2/+1 ribosomal frameshift between codons 8 and 11 of the core protein-encoding region. The ARFP length varies from 126 to 161 amino acids depending on the corresponding genotype. *In vitro* studies have shown that ARFP is a short-lived protein located in the cytoplasm (Roussel 2003) primarily associated with the endoplasmic reticulum (Xu 2003). Detection of anti-F protein antibodies in the serum of HCV-positive subjects indicates that the protein is expressed during infection *in vivo* (Walewski 2001, Komurian-Pradel 2004). However, the functions of ARFP in the viral life cycle are still unknown and remain to be elucidated.

## Viral lifecycle

Due to the absence of a small animal model system and efficient *in vitro* HCV replication systems it has been difficult to investigate the viral life cycle of HCV. The recent development of such systems has offered the opportunity to analyse in detail the different steps of viral replication.



**Figure 2. Current model of the HCV lifecycle.** Designations of cellular components are in red. For a detailed illustration of viral translation and RNA replication, see Pawlotsky 2007. Abbreviations: HCV +ssRNA, single stranded genomic HCV RNA with positive polarity; rough ER, rough endoplasmic reticulum; PM, plasma membrane. For other abbreviations see text.

## Adsorption and viral entry

The most likely candidate as receptor for HCV is the tetraspanin CD81 (Pileri 1998). CD81 is an ubiquitous 25 kd molecule expressed on the surface of a large variety of cells including hepatocytes and PBMCs. Experimental binding of anti-CD81 antibodies to CD81 were reported to inhibit HCV entry into Huh7 cells and primary human hepatocytes (Hsu 2003, Bartosch 2003a, Cormier 2004, McKeating 2004, Zhang 2004, Lindenbach 2005, Wakita 2005). Moreover, gene silencing of CD81 using specific siRNA molecules confirmed the relevance of CD81 in viral entry (Bartosch 2003b, Cormier 2004, Zhang 2004, Akazawa 2007). Finally, expression of CD81 in cell lines lacking CD81 made them permissive for HCV entry (Zhang 2004, Lavillette 2005, Akazawa 2007). However, more recent studies have shown that CD81 alone is not sufficient for HCV viral entry and that co-factors such as scavenger receptor B type I (SR-BI) are needed (Bartosch 2003b, Hsu 2003, Scarselli 2002, Kapadia 2007). Moreover, it appears that CD81 is involved in a post-HCV binding step (Cormier 2004, Koutsoudakis 2006, Bertaud 2006). These findings together with the identification of other host factors involved

in HCV cell entry generate the current model for the early steps of HCV infection (Helle 2008).

Adsorption of HCV to its target cell is the first step of viral entry. Binding is possibly initiated by the interaction of the HCV E2 envelope glycoprotein and the glycosaminoglycan heparan sulfate on the surface of host cells (Germi 2002, Barth 2003, Basu 2004, Heo 2004). Moreover, it is assumed that HCV initiates hepatocyte infection via LDL receptor binding (Agnello 1999, Monazahian 1999, Wünschmann 2000, Nahmias 2006, Molina 2007). This process may be mediated by VLDL or LDL and is reported to be associated with HCV virions in human sera (Bradley 1991, Thomssen 1992, Thomssen 1993). After initial binding the HCV E2 glycoprotein interacts with the SR-BI in cell culture (Scarselli 2002). SR-BI is a protein expressed on the surface of the majority of mammalian cells. It acts as a receptor for LDL as well as HDL (Acton 1994, Acton 1996) emphasizing the role of these compounds for HCV infectivity. Alternative splicing of the SR-BI transcript leads to the expression of a second isoform of the receptor SR-BII (Webb 1998), which also may be involved in HCV entry into target cells (Grove 2007). As is the case for all steps of viral entry the exact mechanism of the HCV E2/SR-BI interaction remains unknown. In some studies it has been reported that HCV binding to SR-BI is a prerequisite for the concomitant or subsequent interaction of the virus with CD81 (Kapadia 2007, Zeisel 2007). The multi-step procedure of HCV cell entry was shown to be even more complex since a cellular factor termed claudin-1 (CLDN1) has been newly identified as involved in this process (Evans 2007). CLDN1 is an integral membrane protein that forms a backbone of tight junctions and is highly expressed in the liver (Furuse 1998). Inhibition assays reveal that CLDN1 involvement occurs downstream of the HCV-CD81 interaction (Evans 2007). Recent findings suggest that CLDN1 could also act as a compound enabling cell-to-cell transfer of hepatitis C virus independently of CD81 (Timpe 2007). Furthermore, it was reported that two other members of the claudin family claudin-6 and claudin-9 may play a role in HCV infection (Zheng 2007, Meertens 2008). The fact that some human cell lines were not susceptible to HCV infection despite expressing SR-BI, CD81, and CLDN1 indicates that other cellular factors are involved in viral entry (Evans 2007). Very recently, a cellular four-transmembrane domain protein named occludin (OCLN) was identified to represent an additional cellular factor essential for the susceptibility of cells to HCV infection (Liu 2009, Ploss 2009). Similar to claudin-1, OCLN is a component of the tight junctions in hepatocytes. All tested cells expressing SR-BI, CD81, CLDN1, and OCLN were susceptible to HCV. Although the precise mechanism of HCV uptake in hepatocytes is still not clarified, these four proteins may represent the complete set of host cell factors necessary for cell-free HCV entry.

After the complex procedure of binding to the different host membrane factors HCV enters the cell in a pH-dependent manner indicating that the virus is internalized via clathrin-mediated endocytosis (Bartosch 2003b, Hsu 2003, Blanchard 2006, Codran 2006). The acidic environment within the endosomes is assumed to trigger HCV E1-E2 glycoprotein-mediated fusion of the viral envelope with the endosome membrane (Blanchard 2006, Meertens 2006, Lavillette 2007).

In summary, HCV adsorption and viral entry into the target cell is a very complex procedure that is not yet fully understood. Despite having identified several host

factors that probably interact with the viral glycoproteins, the precise mechanisms of interaction need to continue to be investigated.

Besides the infection of cells through cell-free HCV it has been documented that HCV can also spread via cell-to-cell transmission (Valli 2006, Valli 2007). This transmission path may differ significantly with regard to the cellular factors needed for HCV entry into cells. CD81 is dispensable for cell-to-cell transmission in cultivated hepatoma cells (Witteveldt 2009). These findings require further investigation in order to analyze the process of cell-to-cell transmission of HCV both *in vitro* and *in vivo*. Antiviral treatment strategies must account for the cellular pathways of both cell-free virus and HCV transmitted via cell-to-cell contact.

## Translation and posttranslational processes

As a result of the fusion of the viral envelope and the endosomal membrane, the genomic HCV RNA is released into the cytoplasm of the cell. As described above, the viral genomic RNA possesses a nontranslated region (NTR) at each terminus. The 5'NTR consists of four distinct domains, I-IV. Domains II-IV form an internal ribosome entry site (IRES) involved in ribosome-binding and subsequent cap-independent initiation of translation (Fukushi 1994, Honda 1999, Tsukiyama-Kohara 1992, Wang 1993). The HCV-IRES binds to the 40S ribosomal subunit complexed with eukaryotic initiation factors 2 and 3 (eIF2 and eIF3), GTP, and the initiator tRNA resulting in the 48S preinitiation complex (Spahn 2001, Otto 2002, Sizova 1998, reviewed in Hellen 1999). Subsequently, the 60S ribosomal subunit associates with that complex leading to the formation of the translational active complex for HCV polyprotein synthesis at the endoplasmic reticulum. HCV RNA contains a large ORF encoding a polyprotein precursor. Posttranslational cleavages lead to 10 functional viral proteins Core, E1, E2, p7, NS2-NS5B. The viral F protein (or ARF protein) originates from a ribosomal frameshift within the first codons of the core-encoding genome region (Walewski 2001, Xu 2001, Varaklioti 2002). Besides several other cellular factors that have been reported to be involved in HCV RNA translation, various viral proteins and genome regions have been shown to enhance or inhibit viral protein synthesis (Zhang 2002, Kato 2002, Wang 2005, Kou 2006, Bradrick 2006, Song 2006).

The precursor polyprotein is processed by at least four distinct peptidases. The cellular signal peptidase (SP) cleaves the N-terminal viral proteins immature core protein, E1, E2, and p7 (Hijikata 1991), while the cellular signal peptide peptidase (SPP) is responsible for the cleavage of the E1 signal sequence from the C-terminus of the immature core protein, resulting in the mature form of the core (McLauchlan 2002). The E1 and E2 proteins remain within the lumen of the ER where they are subsequently N-glycosylated with E1 having 5 and E2 harbouring 11 putative N-glycosylation sites (Duvet 2002).

In addition to the two cellular peptidases HCV encodes two viral enzymes responsible for cleavage of the non-structural proteins NS2 to NS5B within the HCV polyprotein precursor. The zinc-dependent NS2-NS3 cysteine protease consisting of the NS2 protein and the N-terminal portion of NS3 autocatalytically cleaves the junction between NS2 and NS3 (Santolini 1995), whereas the NS3 serine protease cleaves the remaining functional proteins (Bartenschlager 1993, Eckart 1993, Grakoui 1993a, Tomei 1993). However, for its peptidase activity NS3

needs NS4A as a cofactor (Failla 1994, Tanji 1995, Bartenschlager 1995, Lin 1995, Tomei 1996).

## HCV RNA replication

The complex process of HCV RNA replication is poorly understood. The key enzyme for viral RNA replication is NS5B, an RNA-dependent RNA polymerase (RdRp) of HCV (Behrens 1996). In addition, several cellular as well as viral factors have been reported to be part of the HCV RNA replication complex. One important viral factor for the formation of the replication complex appears to be NS4B, which is able to induce an ER-derived membranous web containing most of the non-structural HCV proteins including NS5B (Egger 2002). This web could serve as the platform for the next steps of viral RNA replication. The RdRp uses the previously released genomic positive-stranded HCV RNA as a template for the synthesis of an intermediate minus-stranded RNA. Recently it has been reported that the cellular peptidyl-prolyl isomerases cyclophilin A, B and C (Cyp A, Cyp B, and Cyp C) could stimulate binding of the RdRp to the viral RNA resulting in increased HCV RNA synthesis (Watashi 2005, Nakagawa 2005, Yang 2008, Heck 2009). However, these reports are in part inconsistent and further studies are needed in order to investigate the involvement of cyclophilins in HCV RNA replication.

After the viral polymerase has bound to its template, the NS3 helicase is assumed to unwind putative secondary structures of the template RNA in order to facilitate the synthesis of minus-strand RNA (Jin 1995, Kim 1995). In turn, again with the assistance of the NS3 helicase, the newly synthesized antisense RNA molecule serves as the template for the synthesis of numerous plus-stranded RNA. The resulting sense RNA may be used subsequently as genomic RNA for HCV progeny as well as for polyprotein translation.

## Assembly and release

After the viral proteins, glycoproteins, and the genomic HCV RNA have been synthesized these single components have to be arranged in order to produce infectious virions. As is the case for all other steps in the HCV lifecycle viral assembly is a multi-step procedure involving most viral components along with many cellular factors. Investigation of viral assembly and particle release is still in its infancy since the development of *in vitro* models for the production and release of infectious HCV occurred only recently. Previously, it was reported that core protein molecules were able to self-assemble *in vitro*, yielding nucleocapsid-like particles. More recent findings suggest that viral assembly takes place within the endoplasmic reticulum (Gastaminza 2008) and that lipid droplets (LD) are involved in particle formation (Moradpour 1996, Barba 1997, Miyanari 2007, Shavinskaya 2007, Appel 2008). It appears that LD-associated core protein targets viral non-structural proteins and the HCV RNA replication complex including positive- and negative-stranded RNA from the endoplasmic reticulum to the LD (Miyanari 2007). Beside the core protein, LD-associated NS5A seems to play a key role in the formation of infectious viral particles (Appel 2008). Moreover, E2 molecules are detected in close proximity to LD-associated membranes. Finally, spherical virus-like particles associated with membranes can be seen very close to the LD. Using

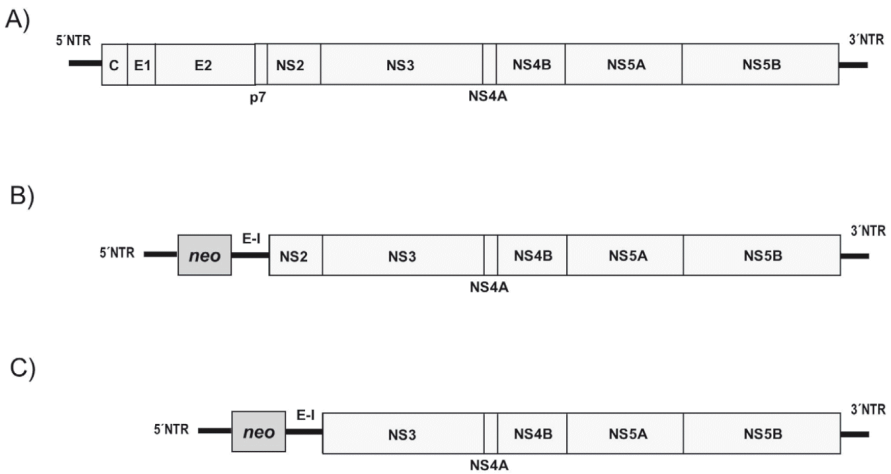


specific antibodies the virus-like particles were shown to contain core protein as well as E2 glycoprotein molecules indicating that these structures may represent infectious HCV (Miyazari 2007). However, the precise mechanisms for the formation and release of infectious HCV particles are still unknown.

## Model systems for HCV research

For a long time HCV research was limited due to a lack of small animal models and efficient cell culture systems. The development of the first HCV replicon system (HCV RNA molecule, or region of HCV RNA, that replicates autonomously from a single origin of replication) 10 years after the identification of the hepatitis C virus offered the opportunity to investigate the molecular biology of HCV infection in a standardized manner (Lohmann 1999).

**HCV replicon systems.** Using total RNA derived from the explanted liver of an individual chronically infected with HCV genotype 1b, the entire HCV ORF sequence was amplified and cloned in two overlapping fragments. The flanking NTRs were amplified and cloned separately and all fragments were assembled into a modified full-length sequence. Transfection experiments with *in vitro* transcripts derived from the full-length clones failed to yield viral replication. For this reason, two different subgenomic replicons consisting of the 5' IRES, the neomycin phosphotransferase gene causing resistance to the antibiotic neomycin, the IRES derived from the encephalomyocarditis virus (EMCV) and the NS2-3'NTR or NS3-3'NTR sequence, respectively, were generated (Figure 3).



**Figure 3. Structure of subgenomic HCV replicons (Lohmann 1999).** This figure illustrates the genetic information of *in vitro* transcripts used for Huh7 transfection. A) Full-length transcript derived from the explanted liver of a chronically infected subject. B) Subgenomic replicon lacking the structural genes and the sequence encoding p7. C) Subgenomic replicon lacking C, E1, E2, p7, and NS2 genes. neo, neomycin phosphotransferase gene; E-I, IRES of the encephalomyocarditis virus (EMCV).

*In vitro* transcripts derived from these constructs lacking the genome region coding for the structural HCV proteins were used to transfect the hepatoma cell line Huh7 (Lohmann 1999). The transcripts are bicistronic, i.e., the first cistron containing the HCV IRES enables the translation of the neomycin phosphotransferase as a tool for efficient selection of successfully transfected cells and the second cistron containing the EMCV IRES directs translation of the HCV-specific proteins. Only some Huh7 clones can replicate replicon-specific RNA in titres of approximately  $10^8$  positive-stranded RNA copies per microgram total RNA. Moreover, all encoded HCV proteins are detected predominantly in the cytoplasm of the transfected Huh7 cells. The development of this replicon is a milestone in HCV research with regard to the investigation of HCV RNA replication and HCV protein analyses.

More recently, the methodology has been improved in order to achieve significantly higher replication efficiency. Enhancement of HCV RNA replication was achieved by the use of replicons harbouring cell culture-adapted point mutations or deletions within the NS genes (Blight 2000, Lohmann 2001, Krieger 2001). Further development has led to the generation of selectable full-length HCV replicons, i.e., genomic replicons that also contain genetic information for the structural proteins Core, E1, and E2 (Pietschmann 2002, Blight 2002). This improvement offered the opportunity to investigate the influence of the structural proteins on HCV replication. Thus it has been possible to analyse the intracellular localisation of these proteins although viral assembly and release has not been achieved.

Another important milestone was reached when a subgenomic replicon based on the HCV genotype 2a strain JFH-1 was generated (Kato 2003). This viral strain derived from a Japanese subject with fulminant hepatitis C (Kato 2001). The corresponding replicons showed higher RNA replication efficiency than previous replicons. Moreover, cell lines distinct from Huh7, such as HepG2 or HeLa were transfected efficiently with transcripts derived from the JFH-1 replicon (Date 2004, Kato 2005).

**HCV pseudotype virus particles (HCVpp).** The generation of retroviral pseudotypes bearing HCV E1 and E2 glycoproteins (HCVpp) offers the opportunity to investigate E1-E2-dependent HCVpp entry into Huh7 cells and primary human hepatocytes (Bartosch 2003a, Hsu 2003, Zhang 2004). In contrast to the HCV replicons where cells were transfected with HCV-specific synthetic RNA molecules, this method allows a detailed analysis of the early steps in the HCV life cycle, e.g., adsorption and viral entry.

**Infectious HCV particles in cell culture (HCVcc).** Transfection of Huh7 and 'cured' Huh7.5 cells with full-length JFH-1 replicons led for the first time to the production of infectious HCV virions (Zhong 2005, Wakita 2005). The construction of a chimera with the core NS2 region derived from HCV strain J6 (genotype 2a) and the remaining sequence derived from JFH-1 improved infectivity. Importantly, the secreted viral particles are infectious in cell culture (HCVcc) (Wakita 2005, Zhong 2005, Lindenbach 2005) as well as in chimeric mice with human liver grafts as well as in chimpanzees (Lindenbach 2006).

An alternative strategy for the production of infectious HCV particles was developed (Heller 2005): a full-length HCV construct (genotype 1b) was placed between two ribozymes in a plasmid containing a tetracycline-responsive promoter.

Huh7 cells were transfected with those plasmids, resulting in efficient viral replication with HCV RNA titres of up to  $10^7$  copies/ml cell culture supernatant.

The development of cell culture systems that allow the production of infectious HCV represents a breakthrough for HCV research and it is now possible to investigate the whole viral life cycle from viral adsorption to virion release. These studies will help to better understand the mechanisms of HCV pathogenesis and they should significantly accelerate the development of HCV-specific antiviral compounds.

**Small animal models.** Very recently, substantial progress was achieved in establishing two mouse models for HCV infection viagenetically humanized mice (Dorner 2011). In this experiment immunocompetent mice were transduced using viral vectors containing the genetic information of four human proteins involved in adsorption and entry of HCV into hepatocytes (CD81, SR-BI, CLDN1, OCLN). This humanisation procedure enabled the authors to infect the transduced mice with HCV. Although this mouse model does not enable complete HCV replication in murine hepatocytes it will be useful to investigate the early steps of HCV infection *in vivo*. Moreover, the approach should be suitable for the evaluation of HCV entry inhibitors and vaccine candidates.

A second group of investigators have chosen another promising strategy for HCV-specific humanisation of mice. After depleting murine hepatocytes human CD34(+) hematopoietic stem cells and hepatocyte progenitors were cotransplanted into transgenic mice leading to efficient engraftment of human leukocytes and hepatocytes, respectively (Washburn 2011). A portion of the humanised mice became infectable with primary HCV isolates resulting in low-level HCV RNA in the murine liver. As a consequence HCV infection induced liver inflammation, hepatitis, and fibrosis. Furthermore, due to the cotransplantation of CD34(+) human hematopoietic stem cells, an HCV-specific T cell immune response could be detected.

Both strategies are promising and have already delivered new insights into viral replication and the pathogenesis of HCV. However, the methods lack some important aspects and need to be improved. As soon as genetically humanised mice that are able to replicate HCV completely are created they can be used for the investigation of HCV pathogenesis and HCV-specific immune responses. The Washburn method should be improved in order to achieve higher HCV replication rates. Moreover, reconstitution of functional human B cells would make this mouse model suitable to study the important HCV-specific antibody response.

## References

- Acton SL, Scherer PE, Lodish HF, et al. Expression cloning of SR-BI, a CD36-related class B scavenger receptor. *J Biol Chem* 1994;269:21003-9. ([Abstract](#))
- Acton S, Rigotti A, Landschulz KT, et al. Identification of scavenger receptor BI as a high-density lipoprotein receptor. *Science* 1996;271:518-20. ([Abstract](#))
- Agnello V, Abel G, Elfahal M, et al. Hepatitis C virus and other Flaviviridae viruses enter cells via low-density lipoprotein receptor. *Proc Natl Acad Sci U S A* 1999;96:12766-71. ([Abstract](#))
- Ago H, Adashi T, Yoshida A, et al. Crystal structure of the RNA-dependent RNA polymerase of hepatitis C virus. *Structure* 1999;7:1417-26. ([Abstract](#))
- Ait-Goughoulte M, Hourieux C, Patient R, et al. Core protein cleavage by signal peptide peptidase is required for hepatitis C virus-like particle assembly. *J Gen Virol* 2006;87:855-60. ([Abstract](#))

- Akazawa D, Date T, Morikawa K, et al. CD81 expression is important for the permissiveness of Huh7 cell clones for heterogeneous hepatitis C virus infection. *J Virol* 81:5036-5045. ([Abstract](#))
- Alter HJ, Holland PV, Purcell RH, et al. Transmissible agent in non-A, non-B hepatitis. *Lancet* 1978;1:459-63. ([Abstract](#))
- Andre P, Komurian-Pradel F, Deforges S, et al. Characterization of low- and very-low-density hepatitis C virus RNA-containing particles. *J Virol* 2002;76:6919-28. ([Abstract](#))
- Appel N, Zayas M, Miller S, et al. Essential role of domain III of nonstructural protein 5A for hepatitis C virus infectious particle assembly. *PLoS Pathog* 2008;4:e1000035. ([Abstract](#))
- Barba G, Harper F, Harada T, et al. Hepatitis C virus core protein shows a cytoplasmic localization and associates to cellular lipid storage droplets. *Proc Natl Acad Sci U S A* 1997;94:1200-5. ([Abstract](#))
- Bartenschlager R, Ahlborn-Laake L, Mous J, et al. Nonstructural protein 3 of hepatitis C virus encodes a serine-type proteinase required for cleavage at the NS3/4 and NS4/5 junctions. *J Virol* 1993;67:3835-44. ([Abstract](#))
- Bartenschlager R, Lohmann V, Wilkinson T, et al. Complex formation between the NS3 serinetype proteinase of the hepatitis C virus and NS4A and its importance for polyprotein maturation. *J Virol* 1995;69:7519-28. ([Abstract](#))
- Barth H, Schäfer C, Adah MI, et al. Cellular binding of hepatitis C virus envelope glycoprotein E2 requires cell surface heparan sulphate. *J Biol Chem* 2003;278:41003-12. ([Abstract](#))
- Bartosch B, Dubuisson J, Cosset FL. Infectious hepatitis C virus pseudoparticles containing functional E1-E2 envelope protein complexes. *J Exp Med* 2003a;197:633-42. ([Abstract](#))
- Bartosch B, Vitelli A, Granier C, et al. Cell entry of hepatitis C virus requires a set of coreceptors that include CD81 and SR-B1 scavenger receptor. *J Biol Chem* 2003b;278:41624-30. ([Abstract](#))
- Behrens SE, Tomei L, DeFrancesco R. Identification and properties of the RNA-dependent RNA polymerase of hepatitis C virus. *EMBO J* 1996;15:12-22. ([Abstract](#))
- Bertaux C, Dragic T. Different domains of CD81 mediate distinct stages of hepatitis C virus pseudoparticle entry. *J Virol* 2006;80:4940-8. ([Abstract](#))
- Blanchard E, Belouzard S, Goueslain L, et al. Hepatitis C virus entry depends on clathrin-mediated endocytosis. *J Virol* 2006;80:6964-72. ([Abstract](#))
- Blight KJ and Rice CM. Secondary structure determination of the conserved 98-base sequence at the 3' terminus of hepatitis C virus genome RNA. *J Virol* 1997;71:7345-52. ([Abstract](#))
- Blight KJ, Kolykhalov AA, Rice CM. Efficient initiation of HCV RNA replication in cell culture. *Science* 2000;290:1972-4. ([Abstract](#))
- Blight KJ, McKeating JA, Rice CM. Highly permissive cell lines for subgenomic and genomic hepatitis C virus RNA replication. *J Virol* 2002;76:13001-14. ([Abstract](#))
- Bradley DW, McCaustland KA, Cook EH, et al. Post-transfusion non-A, non-B hepatitis in chimpanzees: physicochemical evidence that the tubule-forming agent is a small, enveloped virus. *Gastro* 1985;88:773-9. ([Abstract](#))
- Bradley D, McCaustland K, Krawczynski K, et al. Hepatitis C virus: buoyant density of the factor VIII-derived isolate in sucrose. *J Med Virol* 1991;34:206-8. ([Abstract](#))
- Bradrick SS, Walters RW, Gromeier M. The hepatitis C virus 3'-untranslated region or a poly(A) tract promote efficient translation subsequent to the initiation phase. *Nucleic Acids Res* 2006;34:1293-303. ([Abstract](#))
- Branch AD, Stump DD, Gutierrez JA et al. The hepatitis virus alternate reading frame (ARF) and its family of novel products: the alternate reading frame protein/F-protein, the double-frameshift protein, and others. *Semin Liv Dis* 2005;25:105-17.
- Bressanelli S, Tomei L, Roussel A, et al. Crystal structure of the RNA-dependent RNA polymerase of hepatitis C virus. *Proc Natl Acad Sci USA* 1999;96:13034-9. ([Abstract](#))
- Bukh J, Miller RH, Purcell RH. Biology and genetic heterogeneity of hepatitis C virus. *Clin Exp Rheumatol* 1995;Suppl 13:S3-7. ([Abstract](#))
- Choo QL, Kuo G, Weiner AJ, et al. Isolation of a cDNA clone derived from a blood-borne non-A, non-B viral hepatitis genome. *Science* 1989;244:359-62. ([Abstract](#))
- Choo QL, Richman KH, Han JH, et al. Genetic organization and diversity of the hepatitis C virus. *Proc Natl Acad Sci U S A* 1991;88:2451-5. ([Abstract](#))

- Cocquerel L, Meunier JC, Pillez A, et al. A retention signal necessary and sufficient for endoplasmic reticulum localization maps to the transmembrane domain of hepatitis C virus glycoprotein E2. *J Virol* 1998;72:2183-91. ([Abstract](#))
- Cocquerel L, Duvet S, Meunier JC, et al. The transmembrane domain of hepatitis C virus glycoprotein E1 is a signal for static retention in the endoplasmic reticulum. *J Virol* 1999;73:2641-9. ([Abstract](#))
- Cocquerel L, Meunier JC, Op de Beeck A, et al. Coexpression of hepatitis C virus envelope proteins E1 and E2 in *cix* improves the stability of membrane insertion of E2. *J Gen Virol* 2001;82:1629-35. ([Abstract](#))
- Codran A, Royer C, Jaeck D, et al. Entry of hepatitis C virus pseudotypes into primary human hepatocytes by clathrin-dependent endocytosis. *J Gen Virol* 2006;87:2583-93. ([Abstract](#))
- Cormier EG, Tsamis F, Kajumo F, et al. CD81 is an entry coreceptor for hepatitis C virus. *Proc Natl Acad Sci USA* 2004;101:7270-4. ([Abstract](#))
- Date T, Kato T, Miyamoto M, et al. Genotype 2a hepatitis C virus subgenomic replicon can replicate in HepG2 and IMY-N9 cells. *J Biol Chem* 2004;279:22371-6. ([Abstract](#))
- Dorner M, Horwitz JA, Robbins JB, et al. A genetically humanized mouse model for hepatitis C virus infection. *Nature* 2011;474:208-11. ([Abstract](#))
- Duvet S, Cocquerel L, Pillez A, et al. Hepatitis C virus glycoprotein complex localization in the endoplasmic reticulum involves a determinant for retention and not retrieval. *J Biol Chem* 1998;273:32088-95. ([Abstract](#))
- Duvet S, Op de Beeck A, Cocquerel L, et al. Glycosylation of the hepatitis C virus envelope protein E1 occurs posttranslationally in a mannosylphosphoryldolichol-deficient CHO mutant cell line. *Glycobiology* 2002;12:95-101. ([Abstract](#))
- Eckart MR, Selby M, Maisiarz F, et al. The hepatitis C virus encodes a serine protease involved in processing of the putative non-structural proteins from the viral polyprotein precursor. *Biochem Biophys Res Commun* 1993;192:399-406. ([Abstract](#))
- Egger D, Wölk B, Gosert R, et al. Expression of hepatitis C virus proteins induce distinct membrane alterations including candidate viral replication complex. *J Virol* 2002;76:5974-84. ([Abstract](#))
- Einav S, Elazar M, Danieli T, et al. A nucleotide binding motif in hepatitis C virus (HCV) NS4B mediates HCV RNA replication. *J Virol* 2004;78:11288-95. ([Abstract](#))
- Elazar M, Liu P, Rice CM, et al. An N-terminal amphipathic helix in hepatitis C virus (HCV) NS4B mediates membrane association, correct localization of replication complex proteins, and HCV RNA replication. *J Virol* 2004;78:11393-400. ([Abstract](#))
- Enomoto N, Sakuma I, Asahina Y, et al. Comparison of full-length sequences of interferon sensitive and resistant hepatitis C virus 1b. Sensitivity to interferon is conferred by amino acid substitutions in the NS5A region. *J Clin Investig* 1995;96:224-30. ([Abstract](#))
- Enomoto N, Sakuma I, Asahina Y, et al. Mutations in the nonstructural protein 5A gene and response to interferon in patients with chronic hepatitis C virus 1b infection. *N Engl J Med* 1996;334:77-81. ([Abstract](#))
- Evans MJ, von Hahn T, Tschernie DM, et al. Claudin-1 is a hepatitis C virus co-receptor required for a late step in entry. *Nature* 2007;446:801-5. ([Abstract](#))
- Failla C, Tomei L, DeFrancesco R. Both NS3 and NS4A are required for proteolytic processing of hepatitis C virus nonstructural proteins. *J Virol* 1994;68:3753-60. ([Abstract](#))
- Farci P, Shimoda A, Wong D, et al. Prevention of hepatitis C virus infection in chimpanzees by hyperimmune serum against the hypervariable region 1 of the envelope 2 protein. *Proc Nat. Acad Sci USA* 1996;93:15394-9. ([Abstract](#))
- Feinstone SM, Kapikian AZ, Purcell RH, et al. Transfusion-associated hepatitis not due to viral hepatitis type A or B. *N Engl J Med* 1975;292:767-70.
- Feinstone SM, Mihalik KB, Purcell AH, et al. Inactivation of hepatitis B virus and non-A, non-B hepatitis by chloroform. *Infect Immun* 1983;41:816-21. ([Abstract](#))
- Flint M, Maidens C, Loomis-Price LD, et al. Characterization of hepatitis C virus E2 glycoprotein interaction with a putative cellular receptor, CD81. *J Virol* 1999;73:6235-44. ([Abstract](#))
- Friebe P, Lohmann V, Krieger N, et al. Sequences in the 5' nontranslated region of hepatitis C virus required for RNA replication. *J Virol* 2001;75:12047-57. ([Abstract](#))
- Friebe P and Bartschlager R. Genetic analysis of sequences in the 3' nontranslated region of hepatitis C virus that are important for RNA replication. *J Virol* 2002;76:5326-38. ([Abstract](#))

- Friebe P, Boudet J, Simorre JP, et al. Kissing-loop interaction in the 3' end of the hepatitis C virus genome essential of RNA replication. *J Virol* 2005;79:380-92. ([Abstract](#))
- Fried MW, Shiffman ML, Reddy KR, et al. Peginterferon Alfa-2a plus Ribavirin for Chronic Hepatitis C Virus Infection. *N Engl J Med* 2002;347:975-82. ([Abstract](#))
- Fukushi S, Katayama K, Kurihara C, et al. Complete 5' noncoding region is necessary for the efficient internal initiation of hepatitis C virus RNA. *Biochem Biophys Res Commun* 1994;199:425-32. ([Abstract](#))
- Furuse M, Fujita K, Hiiragi T, et al. Claudin-1 and -2: novel integral membrane proteins localizing at tight junctions with no sequence similarity to occludin. *J Cell Biol* 1998;141:1539-50. ([Abstract](#))
- Gardner JP, Durso RJ, Arrigale RR, et al. L-SIGN (CD209L) is a liver-specific capture receptor for hepatitis C virus. *Proc Natl Acad Sci USA* 2003;100:4498-503.
- Gastaminza P, Cheng G, Wieland S, et al. Cellular determinants of hepatitis C virus assembly, maturation, degradation, and secretion. *J Virol* 2008;82:2120-9. ([Abstract](#))
- Germi R, Crance JM, Garin D, et al. Cellular glycosaminoglycans and low density lipoprotein receptor are involved in hepatitis C virus adsorption. *J Med Virol* 2002;68:206-15. ([Abstract](#))
- Grakoui A, McCourt DW, Wychowski C, et al. Characterization of hepatitis C virus-encoded serine proteinase: determination of proteinase-dependent polyprotein cleavage sites. *J Virol* 1993a;67:2832-43. ([Abstract](#))
- Grakoui A, McCourt DW, Wychowski C, et al. A second hepatitis C virus-encoded proteinase. *Proc Natl Acad Sci USA* 1993b;90:10583-7. ([Abstract](#))
- Gretton SN, Taylor AI, McLauchlan J. Mobility of the hepatitis C virus NS4B protein on the endoplasmic reticulum membrane and membrane-associated foci. *J Gen Virol* 2005;86:1415-21. ([Abstract](#))
- Griffin SD, Beales LP, Clarke DS, et al. The p7 protein of hepatitis C virus forms an ion channel that is blocked by the antiviral drug, Amantadine. *FEBS Lett* 2003;535:34-8. ([Abstract](#))
- Grove J, Huby T, Stamatakis Z, et al. Scavenger receptor BI and BII expression levels modulate hepatitis C virus infectivity. *J Virol* 2007;81: 3162-9. ([Abstract](#))
- Haqshenas G, Mackenzie JM, Dong X, et al. Hepatitis C virus p7 protein is localized in the endoplasmic reticulum when it is encoded by a replication-competent genome. *J Gen Virol* 2007;88:134-42. ([Abstract](#))
- Heck JA, Meng X, Frick DN. Cyclophilin B stimulates RNA synthesis by the HCV RNA dependent RNA polymerase. *Biochem Pharmacol* 2009;1173-80. ([Abstract](#))
- Helle F, Dubuisson J. Hepatitis C virus entry into host cells. *Cell Mol Life Sci* 2008, 65:100-12. Hellen CU, Pestova TV. Translation of hepatitis C virus RNA. *J Viral Hepat* 1999;6:79-87.
- Heller TS, Saito J, Auerbach T, et al. An in vitro model of hepatitis C virion production. *Proc Natl Acad Sci USA* 2005;102:2579-83. ([Abstract](#))
- Heo TH, Chang JH, Lee JW, et al. Incomplete humoral immunity against hepatitis C virus is linked with distinct recognition of putative multiple receptors by E2 envelope glycoprotein. *J Immunol* 2004;173:446-55. ([Abstract](#))
- Hollinger FB, Gitnick GL, Aach RD, et al. Non-A, non-B hepatitis transmission in chimpanzees: a project of the Transfusion-transmitted Viruses Study Group. *Intervirology* 1978;10:60-8. ([Abstract](#))
- Honda M, Beard MR, Ping LH, et al. A phylogenetically conserved stem-loop structure at the 5' border of the internal ribosome entry site of hepatitis C virus is required for cap-independent viral translation. *J Virol* 1999;73:1165-74.
- Hsu M, Zhang J, Flint M, et al. Hepatitis C virus glycoproteins mediate pH-dependent cell entry of pseudotyped retroviral particles. *Proc Natl Acad Sci USA* 2003;100:7271-6. ([Abstract](#))
- Hüssy P, Langen H, Mous J, et al. Hepatitis C virus core protein: carboxy-terminal boundaries of two processed species suggest cleavage by a signal peptide peptidase. *Virology* 1996;224-93-104. ([Abstract](#))
- Ito T and Lai MMC. Determination of the secondary structure of and cellular protein binding to the 3'-untranslated region of the hepatitis C virus RNA genome. *J Virol* 1997;71:8698-706. ([Abstract](#))
- Jennings TA, Chen Y, Sikora D, et al. RNA unwinding activity of the hepatitis C virus NS3 helicase is modulated by the NS5B polymerase. *Biochemistry* 2008;47:1126-35. ([Abstract](#))

- Jeong SH, Qiao M, Nascimbeni M, et al. Immunization with hepatitis C virus-like particles induces humoral and cellular immune responses in nonhuman primates. *J Virol* 2004;78:6995-7003. ([Abstract](#))
- Jin L and Peterson DL. Expression, isolation, and characterization of the hepatitis C virus ATPase/RNA helicase. *Arch Biochem Biophys* 1995;323:47-53. ([Abstract](#))
- Jones CT, Murray CL, Eastman DK, et al. Hepatitis C virus p7 and NS2 proteins are essential for production of infectious virus. *J Virol* 2007;81:8374-83. ([Abstract](#))
- Kaito M, Watanabe S, Tsukiyama-Kohara K, et al. Hepatitis C virus particle detected by immunoelectron microscopy study. *J Gen Virol* 1994;75:1755-60. ([Abstract](#))
- Kapadia SB, Barth H, Baumert T, et al. Initiation of hepatitis C virus infection is dependent on cholesterol and cooperativity between CD81 and scavenger receptor B type I. *J Virol* 2007;81:374-83. ([Abstract](#))
- Kato J, Kato N, Yoshida H, et al. Hepatitis C virus NS4A and NS4B proteins suppress translation in vivo. *J Med Virol* 2002;66:187-99. ([Abstract](#))
- Kato N. Molecular virology of hepatitis C virus. *Acta Med Okayama* 2001;55:133-159. ([Abstract](#))
- Kato T, Furusaka A, Miyamoto M, et al. Sequence analysis of hepatitis C virus isolated from a fulminant hepatitis patient. *J Med Virol* 2001;64:334-9. ([Abstract](#))
- Kato T, Date T, Miyamoto M, et al. Efficient replication of the genotype 2a hepatitis C virus subgenomic replicon. *Gastroenterology* 2003;125:1808-17. ([Abstract](#))
- Kato T, Date T, Miyamoto M, et al. Nonhepatic cell lines HeLa and 293 support efficient replication of hepatitis C virus genotype 2a subgenomic replicon. *J Virol* 2005;79:592-6. ([Abstract](#))
- Kim DW, Gwack Y, Han JH, et al. C-terminal domain of the hepatitis C virus NS3 protein contains an RNA helicase activity. *Biochem Biophys Res Commun* 1995;215:160-6. ([Abstract](#))
- Kim YK, Kim CS, Lee SH, et al. Domains I and II in the 5' nontranslated region of the HCV genome are required for RNA replication. *Biochem Biophys Res Commun* 2002;290:105-12. ([Abstract](#))
- Kolykhalov AA, Feinstone SM, Rice SM. Identification of a highly conserved sequence element at the 3' terminus of hepatitis C virus genome RNA. *J Virol* 1996;70:3363-71. ([Abstract](#))
- Kolykhalov AA, Mihalik K, Feinstone SM, et al. Hepatitis C virus-encoded enzymatic activities and conserved RNA elements in the 3' nontranslated region are essential for virus replication in vivo. *J Virol* 2000;74:2046-51. ([Abstract](#))
- Komurian-Pradel F, Rajoharison A, Berland JL, et al. Antigenic relevance of F protein in chronic hepatitis C virus infection. *Hepatology* 2004;40:900-9. ([Abstract](#))
- Kou YH, Chou SM, Wang YM, et al. Hepatitis C virus NS4A inhibits cap-dependent and the viral IRES-mediated translation through interacting with eukaryotic elongation factor 1A. *J Biomed Sci* 2006;13:861-74. ([Abstract](#))
- Koutsoudakis G, Kaul A, Steinmann E, et al. Characterization of the early steps of hepatitis C virus infection by using luciferase reporter viruses. *J Virol* 2006;80:5308-20. ([Abstract](#))
- Krieger N, Lohmann V, Bartenschlager R. Enhancement of hepatitis C virus RNA replication by cell culture-adaptive mutations. *J Virol* 2001;75:4614-24. ([Abstract](#))
- Kuo G, Choo QL, Alter HJ, et al. An assay for circulating antibodies to a major etiologic virus of human non-A, non-B hepatitis. *Science* 1989;244:362-4. ([Abstract](#))
- Lavillette D, Tarr AW, Voisset C, et al. Characterization of host-range and cell entry properties of the major genotypes and subtypes of hepatitis C virus. *Hepatology* 2005;41:265-74. ([Abstract](#))
- Lavillette D, Pécheur EI, Donot P, et al. Characterization of fusion determinants points to the involvement of three discrete regions of both E1 and E2 glycoproteins in the membrane fusion process of hepatitis C virus. *J Virol* 2007;81:8752-65. ([Abstract](#))
- Lesburg CA, Cable MB, Ferrari E, et al. Crystal structure of the RNA-dependent RNA polymerase from hepatitis C virus reveals a fully encircled active site. *Nat Struct Biol* 1999;6:937-43. ([Abstract](#))
- Lin C, Thomson JA, Rice CM. A central region in the hepatitis C virus NS4A protein allows formation of an active NS3-NS4A serine proteinase complex in vivo and in vitro. *J Virol* 1995;69:4373-80. ([Abstract](#))
- Lindenbach BD, Evans MJ, Syder AJ, et al. Complete replication of hepatitis C virus in cell culture. *Science* 2005;309:623-6. ([Abstract](#))

- Lindenbach BD, Meuleman P, Ploss A, et al. Cell culture-grown hepatitis C virus is infectious in vivo and can be recultured in vitro. *Proc Natl Acad Sci USA* 2006;103:3805-9. (Abstract)
- Liu S, Yang W, Shen L, et al. Tight junction proteins claudin-1 and occludin control hepatitis C virus entry and are downregulated during infection to prevent superinfection. *J Virol* 2009;83:2011-4. (Abstract)
- Lohmann V, Körner F, Koch JO, et al. Replication of subgenomic hepatitis C virus RNAs in a hepatoma cell line. *Science* 1999;285:110-3. (Abstract)
- Lohmann V, Körner F, Dobierzewska A, et al. Mutations in hepatitis C virus RNAs conferring cell culture adaptation. *J Virol* 2001;75:1437-49. (Abstract)
- Lozach PY, Lortat-Jacob H, de Lacroix de Lavalette A, et al. DC-SIGN and L-SIGN are high affinity binding receptors for hepatitis C virus glycoprotein E2. *J Biol Chem* 2003;278:20358-66. (Abstract)
- Manns MP, McHutchinson JG, Gordon SC, et al. Peginterferon alfa-2b plus ribavirin compared with interferon alfa-2b plus ribavirin for initial treatment of chronic hepatitis C: a randomised trial. *Lancet* 2001;358:958-65. (Abstract)
- Matsumoto M, Hwang SB, Jeng KS, et al. Homotypic interaction and multimerization of hepatitis C virus core protein. *Virology* 1996;218:43-51. (Abstract)
- McKeating JA, Zhang LQ, Logvinoff C, et al. Diverse hepatitis C virus glycoproteins mediate viral infection in a CD81-dependent manner. *J Virol* 2004;78:8496-505. (Abstract)
- McLauchlan J, Lemberg MK, Hope G, et al. Intramembrane proteolysis promotes trafficking of hepatitis C virus core protein to lipid droplets. *EMBO J* 2002;21:3980-8. (Abstract)
- Meertens L, Bertaux C, Dragic T. Hepatitis C virus entry requires a critical postinternalization step and delivery to early endosomes via clathrin-coated vesicles. *J Virol* 2006;80:11571-8. (Abstract)
- Meertens L, Bertaux C, Cukierman L, et al. The tight junction proteins claudin-1, -6, and -9 are entry cofactors for hepatitis C virus. *J Virol* 2008;82:3555-60. (Abstract)
- Miyanari Y, Atsuzawa K, Usuda N, et al. The lipid droplet is an important organelle for hepatitis C virus production. *Nat Cell Biol* 2007;9:961-9. (Abstract)
- Molina S, Castet V, Fournier-Wirth C, et al. The low-density lipoprotein receptor plays a role in the infection of primary human hepatocytes by hepatitis C virus. *J Hepatol* 2007;46:411-9. (Abstract)
- Monazahian M, Böhme I, Bonk S, et al. Low-density lipoprotein receptor as a candidate receptor for hepatitis C virus. *J Med Virol* 1999;57:223-9. (Abstract)
- Moradpour D, Englert C, Wakita T, et al. Characterization of cell lines allowing tightly regulated expression of hepatitis C virus core protein. *Virology* 1996;222:52-63. (Abstract)
- Nahmias Y, Casali M, Barbe L, et al. Liver endothelial cells promote LDL-R expression and the uptake of HCV-like particles in primary rat and human hepatocytes. *Hepatology* 2006;43:257-65. (Abstract)
- Nakagawa M, Sakamoto N, Tanabe Y, et al. Suppression of hepatitis C virus replication by cyclosporin A is mediated by blockade of cyclophilins. *Gastroenterology* 2005;129:1031-41. (Abstract)
- Ndjomou J, Pybus OG, Matz B. Phylogenetic analysis of hepatitis C virus isolates indicates a unique pattern of endemic infection in Cameroon. *J Gen Virol* 2003;84:2333-41. (Abstract)
- Ohba K, Mizokami M, Lau JYN, et al. Evolutionary relationship of hepatitis C, pesti-, flavi-, plantviruses, and newly discovered GB hepatitis agents. *FEBS Lett* 1996;378:232-4. (Abstract)
- Op de Beeck A, Montserret R, Duvet S, et al. The transmembrane domains of hepatitis C virus envelope glycoprotein E1 and E2 play a major role in heterodimerization. *J Biol Chem* 2000;275:31428-37. (Abstract)
- Otto GA, Lukavsky PJ, Lancaster AM, et al. Ribosomal proteins mediate the hepatitis C virus IRES-HeLa 40S interaction. *RNA* 2002;8:913-23. (Abstract)
- Pavlovic D, Neville DC, Argaud O, et al. The hepatitis C virus p7 protein forms an ion channel that is inhibited by long-alkyl-chain iminosugar derivatives. *Proc Nat. Acad Sci USA* 2003;100:6104-8. (Abstract)
- Pawlotsky JM, Chevalier S, McHutchinson JG. The hepatitis C virus life cycle as a target for new antiviral therapies. *Gastroenterology* 2007;132:1979-98. (Abstract)
- Pietschmann T, Lohmann V, Kaul A, et al. Persistent and transient replication of full-length hepatitis C virus genomes in cell culture. *J Virol* 2002;76:4008-21. (Abstract)



- Pileri P, Uematsu Y, Campagnoli S, et al. Binding of hepatitis C virus to CD81. *Science* 1998, 282:938-941. Ploss A, Evans MJ, Gaysinskaya VA, et al. Human occluding is a hepatitis C virus entry factor required for infection of mouse cells. *Nature* 2009;457:882-6. ([Abstract](#))
- Ploss A, Evans MJ, Gaysinskaya VA, et al. Human occluding is a hepatitis C virus entry factor required for infection of mouse cells. *Nature* 2009;457:882-6. ([Abstract](#))
- Pöhlmann S, Zhang J, Baribaud F, et al. Hepatitis C virus glycoproteins interact with DC-SIGN and DC-SIGNR. *J Virol* 2003;77:4070-80. ([Abstract](#))
- Poynard T, Bedossa P, Opolon P et al. Natural history of liver fibrosis progression in patients with chronic hepatitis C. *Lancet* 1997;349:825-33. ([Abstract](#))
- Prince AM, Huima-Byron T, Parker TS, et al. Visualization of hepatitis C virions and putative defective interfering particles isolated from low-density lipoproteins. *J Viral Hepat* 1996;3:11-7. ([Abstract](#))
- Qiao M, Ashok M, Bernard KA, et al. Induction of sterilizing immunity against West Nile virus (WNV) by immunization with WNV-like particles produced in insect cells. *J Infect Dis* 2004;190:2104-8. ([Abstract](#))
- Roussel J, Pillez A, Montpellier C, et al. Characterization of the expression of the hepatitis C virus F protein. *J Gen Virol* 2003;84:1751-9. ([Abstract](#))
- Sakai A, Claire MS, Faulk K, et al. The p7 polypeptide of hepatitis C virus is critical for infectivity and contains functionally important genotype-specific sequences. *Proc Nat. Acad Sci USA* 2003;100:11646-51. ([Abstract](#))
- Santolini E, Migliaccio G, La Monica N. Biosynthesis and biochemical properties of the hepatitis C virus core protein. *J Virol* 1994;68:3631-41. ([Abstract](#))
- Santolini E, Pacini L, Fipaldini C, et al. The NS2 protein of hepatitis C virus is a transmembrane polypeptide. *J Virol* 1995;69:7461-71. ([Abstract](#))
- Scarselli E, Ansuini H, Cerino R, et al. The human scavenger receptor class B type I is a novel candidate receptor for the hepatitis C virus. *EMBO J* 2002;21:5017-25. ([Abstract](#))
- Schmidt-Mende J, Bieck E, Hugle T, et al. Determinants for membrane association of the hepatitis C virus RNA-dependent RNA polymerase. *J Biol Chem* 2001;276:44052-63. ([Abstract](#))
- Shavinskaya A, Boulant S, Penin F, et al. The lipid droplet binding domain of hepatitis C virus core protein is a major determinant for efficient virus assembly. *J Biol Chem* 2007;282:37158-69. ([Abstract](#))
- Shimizu YK, Feinstone SM, Kohara M, et al. Hepatitis C virus: detection of intracellular virus particles by electron microscopy. *Hepatology* 1996a;23:205-9. ([Abstract](#))
- Shimizu YK, Igarashi H, Kiyohara T, et al. A hyperimmune serum against a synthetic peptide corresponding to the hypervariable region 1 of hepatitis C virus can prevent viral infection in cell cultures. *Virology* 1996b;223:409-12. ([Abstract](#))
- Simmonds P. The origin and evolution of hepatitis viruses in humans. *J Gen Virol* 2001, 82:693-712. Simmonds P. Genetic diversity and evolution of hepatitis C virus - 15 years on. *J Gen Virol* 2004;85:3173-88. ([Abstract](#))
- Simmonds P, Bukh J, Combet C, et al. Consensus proposals for a unified system of nomenclature of hepatitis C virus genotypes. *Hepatology* 2005;42:962-73. ([Abstract](#))
- Simons JN, Leary TP, Dawson GJ, et al. Isolation of novel virus-like sequences associated with human hepatitis. *Nat Med* 1995;1:564-9. ([Abstract](#))
- Sizova DV, Kolupaeva VG, Pestova TV, et al. Specific interaction of eukaryotic translation initiation factor 3 with the 5' nontranslated regions of hepatitis C virus and classical swine fever virus RNAs. *J Virol* 1998;72:4775-82. ([Abstract](#))
- Song Y, Friebe P, Tzima E, et al. The hepatitis C virus RNA 3'-untranslated region strongly enhances translation directed by the internal ribosome entry site. *J Virol* 2006;80:11579-88. ([Abstract](#))
- Spahn CM, Kieft JS, Grassucci RA, et al. Hepatitis C virus IRES RNA-induced changes in the conformation of the 40s ribosomal subunit. *Science* 2001;291:1959-62. ([Abstract](#))
- Takahashi K, Kishimoto S, Yoshizawa H, et al. p26 protein and 33-nm particle associated with nucleocapsid of hepatitis C virus recovered from the circulation of infected hosts. *Virology* 1992;191:431-4. ([Abstract](#))
- Tanaka T, Kato N, Cho MJ, et al. A novel sequence found at the 3' terminus of hepatitis C virus genome. *Biochem Biophys Res* 1995;215:744-9. ([Abstract](#))
- Tanaka T, Kato N, Cho MJ, et al. Structure of the 3' terminus of the hepatitis C virus genome. *J Virol* 1996;70:3307-12. ([Abstract](#))

- Tanji Y, Hijikata M, Satoh S, et al. Hepatitis C virus-encoded nonstructural protein NS4A has versatile functions in viral protein processing. *J Virol* 1995;69:1575-81. (Abstract)
- Thiel HJ, Collett MS, Gould EA et al. Family Flaviviridae, In: Fauquet CM, Mayo MA, Maniloff J et al., eds. *Virus Taxonomy: VIIIth Report of the International Committee on Taxonomy of Viruses*. San Diego: Academic Press; 2005:979-96.
- Thomssen R, Bonk S, Propfe C, et al. Association of hepatitis C virus in human sera with lipoprotein. *Med Microbiol Immunol* 1992;181:293-300. (Abstract)
- Thomssen R, Bonk S, Thiele A. Density heterogeneities of hepatitis C virus in human sera due to the binding of beta-lipoproteins and immunoglobulins. *Med Microbiol Immunol* 1993;182:329-34. (Abstract)
- Timpe JM, Stamatakis Z, Jennings A, et al. Hepatitis C virus cell-cell transmission in hepatoma cells in the presence of neutralizing antibodies. *Hepatology* 2007;47:17-24. (Abstract)
- Tomei L, Failla C, Santolini E, et al. NS3 is a Serine protease required for processing of hepatitis C virus polyprotein. *J Virol* 1993;67:4017-26. (Abstract)
- Tomei L, Failla C, Vitale RL, et al. A central hydrophobic domain of the hepatitis C virus NS4A protein is necessary and sufficient for the activation of the NS3 protease. *J Gen Virol* 1996;77:1065-70. (Abstract)
- Tong MJ, el-Farra NS, Reikes AR et al. Clinical outcomes after transfusion-associated hepatitis C. *N Engl J Med* 1995;332:1463-6. (Abstract)
- Tsukiyama-Kohara K, Iizuka N, Kohara M, et al. Internal ribosome entry site within hepatitis C virus RNA. *J Virol* 1992;66:1476-83. (Abstract)
- Valli MB, Serafino A, Crema A, et al. Transmission in vitro of hepatitis C virus from persistently infected human B-cells to hepatoma cells by cell-to-cell contact. *J Med Virol* 2006;78:192-201. (Abstract)
- Valli MB, Crema A, Lanzilli G, et al. Molecular and cellular determinants of cell-to-cell transmission of HCV in vitro. *J Med Virol* 2007;79:1491-9. (Abstract)
- Varaklioti A, Vassilaki N, Georgopoulou U, et al. Alternate translation occurs within the core coding region of the hepatitis C viral genome. *J Biol Chem* 2002;277:13-21. (Abstract)
- Wakita T, Pietschmann T, Kato T, et al. Production of infectious hepatitis C virus in tissue culture from a cloned viral genome. *Nat Med* 2005;11:791-6. (Abstract)
- Walewski JL, Keller TR, Stump DD, et al. Evidence for a new hepatitis C virus antigen encoded in an overlapping reading frame. *RNA* 2001;7:710-21. (Abstract)
- Wang C, Sarnow P, Siddiqui A. Translation of human hepatitis C virus RNA in cultured cells is mediated by an internal ribosome-binding mechanism. *J Virol* 1993;67:3338-44. (Abstract)
- Wang H, Shen XT, Ye R, et al. Roles of the polypyrimidine tract and 3' noncoding region of hepatitis C virus RNA in the internal ribosome entry site-mediated translation. *Arch Virol* 2005;150:1085-99. (Abstract)
- Washburn ML, Bility MT, Zhang L, et al. A humanized mouse model to study hepatitis C virus infection, immune response, and liver disease. *Gastroenterology* 2011;140:1334-44. (Abstract)
- Watashi K, Ishii N, Hijikata M, et al. Cyclophilin B is a functional regulator of hepatitis C virus RNA polymerase. *Mol Cell* 2005;19:111-22.
- Webb NR, Connell PM, Graf GA, et al. SR-BII, an isoform of the scavenger receptor BI containing an alternate cytoplasmic tail, mediates lipid transfer between high-density lipoprotein and cells. *J Biol Chem* 1998;273:15241-8. (Abstract)
- Weihofen A, Binns K, Lemberg MK, et al. Identification of signal peptide peptidase, a presenilin-type aspartic protease. *Science* 2002;296:2215-8. (Abstract)
- Weiner AJ, Brauer MJ, Rosenblatt J, et al. Variable and hypervariable domains are found in the regions of HCV corresponding to the flavivirus envelope and NS1 proteins and the pestivirus envelope glycoproteins. *Virology* 1991;180:842-8. (Abstract)
- Witteveldt J, Evans MJ, Bitzegeio J, et al. CD81 is dispensable for hepatitis C virus cell-to-cell transmission in hepatoma cells. *J Gen Virol* 2009;90:48-58. (Abstract)
- Wölk B, Sansonno D, Kräusslich HG, et al. Subcellular localization, stability, and transcleavage competence of the hepatitis C virus NS3-NS4A complex expressed in tetracycline-regulated cell lines. *J Virol* 2000;74:2293-304. (Abstract)
- Wünschmann S, Medh JD, Klinzmann D, et al. Characterization of hepatitis C virus (HCV) and HCV E2 interactions with CD81 and the low-density lipoprotein receptor. *J Virol* 2000;74:10055-62. (Abstract)
- Xu Z, Choi J, Yen TS, et al. Synthesis of a novel hepatitis C virus protein by ribosomal frameshift. *EMBO J* 2001;20:3840-8. (Abstract)

- Xu Z, Choi J, Lu W, et al. Hepatitis C virus F protein is a short-lived protein associated with the endoplasmic reticulum. *J Virol* 2003;77:1578-83. ([Abstract](#))
- Yanagi M, St Claire M, Emerson SU. In vivo analysis of the 3' untranslated region of the hepatitis C virus after in vitro mutagenesis of an infectious cDNA clone. *Proc Natl Acad Sci USA* 1999;96:2291-5. ([Abstract](#))
- Yang F, Robotham JM, Nelson HB, et al. Cyclophilin A is an essential cofactor for hepatitis C virus infection and the principal mediator of cyclosporine resistance in vitro. *J Virol* 2008;82:5269-78. ([Abstract](#))
- Yi M and Lemon SM. 3' Nontranslated RNA signals required for replication of hepatitis C virus RNA. *J Virol* 2003;77:3557-68. ([Abstract](#))
- Yi M, Villanueva RA, Thomas DL, et al. Production of infectious genotype 1a hepatitis C virus (Hutchinson strain) in cultured hepatoma cells. *Proc Natl Acad Sci USA* 2006;103:2310-5. ([Abstract](#))
- You S and Rice CM. 3' RNA elements in hepatitis C virus replication: kissing partners and long poly(U). *J Virol* 2008;82:184-95. ([Abstract](#))
- Yu X, Qiao M, Atanasov I, et al. Cryo-electron microscopy and three-dimensional reconstructions of hepatitis C virus particles. *Virology* 2007;367:126-34. ([Abstract](#))
- Zeisel MB, Koutsoudakis G, Schnober EK, et al. Scavenger receptor class B type I is a key host factor for hepatitis C virus infection required for an entry step closely linked to CD81. *Hepatology* 2007;46:1722-31. ([Abstract](#))
- Zhang J, Yamada O, Yoshida H, et al. Autogenous translational inhibition of core protein: implication for switch from translation to RNA replication in hepatitis C virus. *Virology* 2002;293:141-50. ([Abstract](#))
- Zhang LQ, Randall G, Higginbottom A, et al. CD81 is required for hepatitis C virus glycoprotein-mediated viral infection. *J Virol* 2004;78:1448-55. ([Abstract](#))
- Zheng A, Yuan F, Li Y, et al. Claudin-6 and claudin-9 function as additional coreceptors for hepatitis C virus. *J Virol* 2007;81:12465-71. ([Abstract](#))
- Zhong J, Gastaminza P, Cheng G, et al. Robust hepatitis C virus infection in vitro. *Proc Natl Acad Sci USA* 2005;102:9294-9. ([Abstract](#))

## 7. Prophylaxis and Vaccination

*Heiner Wedemeyer*

### Introduction

Understanding the biology and modes of transmission of hepatitis viruses has significantly improved over the last decades. Still, prophylactic vaccines are only available against HAV and HBV. Although an enormous amount of basic and clinical research has been performed to develop a vaccine against hepatitis C, it is very unlikely that a prophylactic or therapeutic HCV vaccine will be licensed in the next few years. A first Phase III vaccine trial against hepatitis E has been successful in China; nevertheless, it is currently unknown if or when this vaccine will become available in other countries. Prophylaxis of HCV, HDV (for HBV-infected patients) and HEV infection therefore must still occur by avoiding all routes of exposure to the respective hepatitis viruses discussed in detail in Chapters 1-4.

### Prophylaxis of hepatitis viruses

#### Hepatitis A and E

The hepatitis A and E viruses are usually transmitted by oral ingestion of contaminated food or water. Thus, particular caution is warranted when individuals from low endemic areas such as western Europe and the US travel to countries with a high prevalence of HAV and HEV infections. In addition, hepatitis E can also be a zoonosis. A German case-control study identified 32% of all reported HEV infections as being autochthonous infections, meaning not associated with travelling to endemic countries (Wichmann 2008). In these patients consumption of offal and wild boar meat was independently associated with HEV infection. This may have significant implications for immunosuppressed patients as cases of chronic hepatitis E with the development of advanced fibrosis have been described in patients after organ transplantation (Kamar 2008, Pischke 2010). HEV has frequently been detected in the meat of pigs; Danish farmers show a higher prevalence of HEV antibodies. Importantly, zoonotic HEV infection is usually caused by HEV genotype 3 while HEV genotype 1 can be found in travelling-associated hepatitis E.

HAV and HEV can also be transmitted by blood transfusion although cases are extremely rare.

## Hepatitis B and D

HBV and HDV were transmitted frequently by blood transfusion before HBsAg testing of all blood products was introduced in the 1970s. Since then, vertical transmission and sexual exposure have become the most frequent routes of HBV infection. Medical procedures still represent a potential source for HBV transmissions and thus strict and careful application of standard hygienic precautions for all medical interventions are absolutely mandatory, and not only in endemic areas. This holds true in particular for immunocompromised individuals who are highly susceptible to HBV infection as HBV is characterized by a very high infectivity (Wedemeyer 1998). Moreover, immunosuppressed patients are at risk for reactivation of occult HBV infection after serological recovery from hepatitis B. Treatments with high doses of steroids and rituximab have especially been identified as major risk factors for HBV reactivation (Lalazar 2007, Loomba 2008). After a new diagnosis of HBV infection, all family members of the patient need to be tested for their immune status against HBV. Immediate active vaccination is recommended for all anti-HBc-negative contact persons. HBsAg-positive individuals should use condoms during sexual intercourse if it is not known if the partner has been vaccinated. Non-immune individuals who have experienced an injury and were exposed to HBsAg-positive fluids should undergo passive immunization with anti-HBs as soon as possible, preferentially within 2-12 hours (Cornberg 2011).

## Hepatitis C

Less than 1% of individuals who are exposed to HCV by an injury with contaminated needles develop acute HCV infection. At Hannover Medical School, not a single HCV seroconversion occurred after 166 occupational exposures with anti-HCV positive blood in a period of 6 years (2000-2005). A systematic review of the literature identified 22 studies including a total of 6,956 injuries with HCV contaminated needles. Only 52 individuals (0.75%) became infected. The risk of acute HCV infection was lower in Europe at 0.42% compared to eastern Asia at 1.5% (Kubitschke 2007). Thus, the risk of acquiring HCV infection after a needlestick injury is lower than frequently reported. Worldwide differences in HCV seroconversion rates may suggest that genetic factors provide some level of natural resistance against HCV. Factors associated with a higher risk of HCV transmission are likely to be the level of HCV viremia in the index patient, the amount of transmitted fluid and the duration between contamination of the respective needle and injury. Suggested follow-up procedures after needlestick injury are shown in Figure 1.

Sexual intercourse with HCV-infected persons has clearly been identified as a risk for HCV infection, as about 10-20% of patients with acute hepatitis C report this as a potential risk factor (Deterding 2009; Table 1). However, there is also evidence that the risk of acquiring HCV sexually is extremely low in individuals in stable partnerships who avoid injuries. Cohort studies including more than 500 HCV-infected patients followed over periods of more than 4 years could not identify any cases of confirmed HCV transmission. Thus, guidelines generally do not

recommend the use of condoms in monogamous relationships (EASL 2011). However, this does not hold true for HIV-positive homosexual men. Several outbreaks of acute hepatitis C have been described in this scenario (Fox 2008, Low 2008, van de Laar 2009). Transmitted cases had more sexual partners, increased levels of high-risk sexual behaviour (in particular, fisting) and were more likely to have shared drugs via a nasal or anal route than controls (Turner 2006).

Due to the low HCV prevalence in most European countries and due to a relatively low vertical transmission rate of 1-6%, general screening of pregnant women for anti-HCV is not recommended. Interestingly, transmission may be higher for girls than for boys (European Pediatric Hepatitis C Virus Network 2005). Transmission rates may be higher in HIV-infected women so pregnant women should be tested for hepatitis C. Other factors possibly associated with high transmission rates are the level of HCV viremia, maternal intravenous drug use, and specific HLA types of the children. Cesarean sections are not recommended for HCV RNA positive mothers as there is no clear evidence that these reduce transmission rates. Children of HCV-infected mothers should be tested for HCV RNA after 1 month as maternal anti-HCV antibodies can be detected for several months after birth. Mothers with chronic hepatitis C can breast-feed their children as long as they are HIV-negative and do not use intravenous drugs (European Pediatric Hepatitis C Virus Network 2001, EASL 2011).

The Spanish Acute HCV Study Group has identified hospital admission as a significant risk factor for acquiring HCV infection in Spain (Martinez-Bauer 2008). The data are in line with reports from Italy (Santantonio 2006) and the USA (Corey 2006). We have reported data from the German Hep-Net Acute HCV Studies and found 38 cases (15% of the entire cohort) of acute HCV patients who reported a medical procedure as the most likely risk factor for having acquired HCV (Deterding 2008). The majority of those were hospital admissions with surgery in 30 cases; other invasive procedures, including dental treatment, were present in only 4 cases. Medical procedures were significantly more often the probable cause of infection in patients older than 30 years of age ( $p=0.002$ ) but not associated with disease severity or time from exposure to onset of symptoms. Thus, medical treatment per se still represents a significant risk factor for HCV infection – even in developed countries. Strict adherence to universal precaution guidelines is urgently warranted.

## **Vaccination against hepatitis A**

The first active vaccine against HAV was licensed in 1995. The currently available inactive vaccines are manufactured from cell culture-adapted HAV, grown either in human fibroblasts or diploid cells (Nothdurft 2008). Two doses of the vaccine are recommended. The second dose should be given between 6 and 18 months after the first dose. All vaccines are highly immunogenic and basically all vaccinated healthy persons develop protective anti-HAV antibodies. Similar vaccine responses are obtained in both children and adults and no relevant regional differences in response to HAV vaccination have been observed. The weakest vaccine responses have been described for young children receiving a 0, 1, 2 months schedule (Hammit 2008). Patients with chronic liver disease do respond to vaccination but may display lower anti-HAV titers (Keeffe 1998). A combined vaccine against HAV and HBV is

available that needs to be administered three times, on a 0, 1, and 6 months schedule. More than 80% of healthy individuals have detectable HAV antibodies by day 21 applying an accelerated vaccine schedule of 0, 7 and 21 days using the combined HAV/HBV vaccine, and all study subjects were immune against HAV by 2 months (Kallinowski 2003).

HAV vaccines are very well tolerated and no serious adverse events have been linked with the administration of HAV vaccines (Nothdurft 2008). The vaccine can safely be given together with other vaccines or immunoglobulins without compromising the development of protective antibodies.

Vaccination is recommended for non-immune individuals who plan to travel to endemic countries, medical health professionals, homosexual men, persons in contact with hepatitis A patients, and individuals with chronic liver diseases. Some studies have suggested that patients with chronic hepatitis C have a higher risk of developing fulminant hepatitis A (Vento 1998) although this finding has not been confirmed by other investigators (Deterding 2006). The implementation of childhood vaccination programs has led to significant and impressive declines of HAV infections in several countries, justifying further efforts aiming at controlling the spread of HAV in endemic countries (Hendrickx 2008). It is important to highlight that most studies have confirmed that HAV vaccination is cost-effective (Rein 2008, Hollinger 2007).

Long-term follow-up studies after complete HAV vaccination have been published. Interestingly, anti-HAV titers sharply decline during the first year after vaccination but remain detectable in almost all individuals for at least 10-15 years after vaccination (Van Herck 2011). Based on these studies it was estimated that protective anti-HAV antibodies should persist for at least 27-30 years after successful vaccination (Hammit 2008, Bovier 2010).

## **Vaccination against hepatitis B**

The hepatitis B vaccine is the first vaccine able to reduce the incidence of cancer. In Taiwan, a significant decline in cases of childhood hepatocellular carcinoma has been observed since the implementation of programs to vaccinate all infants against HBV (Chang 1997). This landmark study impressively highlighted the usefulness of universal vaccination against HBV in endemic countries. Controversial discussions are ongoing regarding to what extent universal vaccination against HBV may be cost-effective in low-endemic places such as the UK, the Netherlands or Scandinavia (Zuckerman 2007). In 1992 the World Health Organization recommended general vaccination against hepatitis B. It should be possible to eradicate hepatitis B by worldwide implementation of this recommendation, because humans are the only epidemiologically relevant host for HBV. 179 countries have introduced a hepatitis B vaccine in their national infant immunization schedules by the end of 2010, including parts of India and the Sudan (WHO 2011).

The first plasma-derived hepatitis B vaccine was approved by FDA in 1981. Recombinant vaccines consisting of HBsAg produced in yeast became available in 1986. In the US, two recombinant vaccines are licensed (Recombivax® and Engerix-B®) while additional vaccines are used in other countries. The vaccines are administered three times, on a 0, 1, and 6 months schedule.

**Who should be vaccinated?** (The German Guidelines (Cornberg 2011))

- Hepatitis B high-risk persons working in health care settings including trainees, students, cleaning personnel;
- Personnel in psychiatric facilities or comparable welfare institutions for cerebrally damaged or disturbed patients; other persons who are at risk because of blood contact with possibly infected persons dependent on the risk evaluation, e.g., persons giving first aid professionally or voluntarily, employees of ambulance services, police officers, social workers, and prison staff who have contact with drug addicts;
- Patients with chronic kidney disease, dialysis patients, patients with frequent blood or blood component transfusions (e.g., hemophiliacs), patients prior to extensive surgery (e.g., before operations using heart-lung machine. The urgency of the operation and the patient's wish for vaccination protection are of primary importance);
- Persons with chronic liver disease including chronic diseases with liver involvement as well as HIV-positive persons without HBV markers;
- Persons at risk of contact with HBsAg carriers in the family or shared housing, sexual partners of HBsAg carriers;
- Patients in psychiatric facilities or residents of comparable welfare institutions for cerebrally damaged or disturbed persons as well as persons in sheltered workshops;
- Special high-risk groups, e.g., homosexually active men, regular drug users, sex workers, prisoners serving extended sentences;
- Persons at risk of contacting HBsAg carriers in facilities (kindergarten, children's homes, nursing homes, school classes, day care groups);
- Persons travelling to regions with high hepatitis B prevalence for an extended period of time or with expected close contact with the local population;
- Persons who have been injured by possibly contaminated items, e.g., needle puncture (see post-exposition prophylaxis);
- Infants of HBsAg-positive mothers or of mothers with unknown HBsAg status (independent of weight at birth) (see post-exposition prophylaxis).

Routine testing for previous contact with hepatitis B is not necessary before vaccination unless the person belongs to a risk group and may have acquired hepatitis B before. Pre-vaccine testing is usually not cost-effective in populations with anti-HBc prevalence below 20%. Vaccination of an HBsAg-positive individual can be performed without any danger – however, it is ineffective.

## **Efficacy of vaccination against hepatitis B**

A response to HBV vaccination is determined by the development of anti-HBs antibodies, detectable in 90-95% of individuals one month after a complete vaccination schedule (Wedemeyer 2007, Coates 2001). Responses are lower in elderly people and much weaker in immunocompromised persons such as organ transplant recipients, patients receiving hemodialysis and HIV-infected individuals. In case of vaccine non-response, another three courses of vaccine should be administered and the dose of the vaccine should be increased. Other possibilities to



increase the immunogenicity of HBV vaccines include intradermal application and coadministration of adjuvants and cytokines (Cornberg 2011). The response to vaccination should be controlled in high-risk individuals such as medical health professionals and immunocompromised persons. Some guidelines also recommend testing elderly persons after vaccinations as vaccine response does decline more rapidly in the elderly (Wolters 2003).

### **Post-exposure prophylaxis**

Non-immune persons who have been in contact with HBV-contaminated materials (e.g., needles) or who have had sexual intercourse with an HBV-infected person should undergo active-passive immunization (active immunization plus hepatitis B immunoglobulin) as soon as possible – preferentially within the first 48 hours of exposure to HBV. Individuals previously vaccinated but who have an anti-HBs titer of <10 IU/L should also be vaccinated both actively and passively. No action is required if an anti-HBs titer of >100 IU/l is documented; active vaccination alone is sufficient for persons with intermediate anti-HBs titers between 10 and 100 IU/L (Cornberg 2011).

### **Safety of HBV vaccines**

Several hundred million individuals have been vaccinated against hepatitis B. The vaccine is very well tolerated. Injection site reactions in the first 1-3 days and mild general reactions are common, although they are usually not long lasting. Whether there is a causal relationship between the vaccination and the seldomly observed neurological disorders occurring around the time of vaccination is not clear. In the majority of these case reports the concomitant events most likely occurred coincidentally and are independent and not causally related. That hepatitis B vaccination causes and induces acute episodes of multiple sclerosis or other demyelating diseases are repeatedly discussed (Geier 2001, Hernan 2004, Girard 2005). However, there are no scientific facts proving such a relationship. Numerous studies have not been able to find a causal relationship between the postulated disease and the vaccination (Sadovnick 2000, Monteyne 2000, Ascherio 2001, Confavreux 2001, Schattner 2005).

### **Long-term immunogenicity of hepatitis B vaccination**

Several studies have been published in recent years investigating the long-term efficacy of HBV vaccination. After 10-15 years, between one third and two thirds of vaccinated individuals have completely lost anti-HBs antibodies and only a minority maintain titers of >100 IU/L. However, in low/intermediate endemic countries such as Italy, this loss in protective humoral immunity did not lead to many cases of acute or even chronic HBV infection (Zanetti 2005). To what extent memory B and T cell responses contribute to a relative protection against HBV in the absence of anti-HBs remains to be determined. Nevertheless, in high-endemic countries such as Gambia a significant proportion of infants develop anti-HBc indicating active HBV infection (18%) and some children develop chronic hepatitis B (van der Sande 2007). Thus, persons at risk should receive booster immunization if HBs antibodies have been lost.

## Prevention of vertical HBV transmission

Infants of HBsAg-positive mothers should be immunized actively and passively within 12 hours of birth. This is very important as the vertical HBV transmission rate can be reduced from 95% to <5% (Ranger-Rogez 2004). Mothers with high HBV viremia, of >1 million IU/ml, should receive in addition antiviral therapy with a potent HBV polymerase inhibitor (European Association For The Study Of The Liver 2009, Peterson 2011, Han 2011). Tenofovir and telbivudine have been classified as Category B drugs by the FDA and can therefore be given during pregnancy as no increased rates of birth defects have been reported. If active/passive immunization has been performed, there is no need to recommend cesarean section. Mothers of vaccinated infants can breastfeed unless antiviral medications are being taken by the mother, which can pass through breast milk.

## Vaccination against hepatitis C

No prophylactic or therapeutic vaccine against hepatitis C is available. As re-infections after spontaneous or treatment-induced recovery from hepatitis C virus infection have frequently been reported, the aim of a prophylactic vaccine will very likely be not to prevent completely an infection with HCV but rather to modulate immune responses in such a way that the frequency of evolution to a chronic state can be reduced (Torresi 2011).

HCV specific T cell responses play an important role in the natural course of HCV infection. The adaptive T cell response is mediated both by CD4+ helper T cells and CD8+ killer T cells. Several groups have consistently found an association between a strong, multispecific and maintained HCV-specific CD4+ and CD8+ T cell response and the resolution of acute HCV infection. While CD4+ T cells seem to be present for several years after recovery, there are conflicting data whether HCV-specific CD8+ T cells responses persist or decline over time (Wiegand 2007). However, several studies have observed durable HCV-specific T cells in HCV-seronegative individuals who were exposed to HCV by occupational exposure or as household members of HCV-positive partners, but who never became HCV RNA positive. These observations suggest that HCV-specific T cells may be induced upon subclinical exposure and may contribute to protection against clinically apparent HCV infection. T cell responses are usually much weaker in chronic hepatitis C. The frequency of specific cells is low but also effector function of HCV-specific T cells is impaired. Different mechanisms are discussed as being responsible for this impaired T cell function, including higher frequencies of regulatory T cells (Tregs), altered dendritic cell activity, upregulation of inhibitory molecules such as PD-1, CTLA-4 or 2B4 on T cells and escape mutations. HCV proteins can directly or indirectly contribute to altered functions of different immune cells (Rehermann 2009).

To what extent humoral immune responses against HCV contribute to spontaneous clearance of acute hepatitis C is less clear. Higher levels of neutralizing antibodies early during the infection are associated with viral clearance (Pestka 2007). Antibodies with neutralizing properties occur at high levels during chronic infection, although HCV constantly escapes these neutralizing antibodies (von Hahn 2007). Yet, no completely sterilizing humoral anti-HCV immunity exists in the long-term after recovery (Rehermann 2009). Attempts to use neutralizing antibodies

to prevent HCV re-infection after liver transplant have not been successful (Gordon 2011).

Few Phase I vaccine studies based either on vaccination with HCV peptides, HCV proteins alone or in combination with distinct adjuvants or recombinant viral vectors expressing HCV proteins have been completed (Torresi 2011). HCV-specific T cells or antibodies against HCV were induced by these vaccines in healthy individuals. Studies in chimpanzees have shown that it is very unlikely that a vaccine will be completely protective against heterologous HCV infections. However, a reasonable approach might be the development of a vaccine that does not confer 100% protection against acute infection but prevents progression of acute hepatitis C to chronic infection. In any case, there are no vaccine programs that have reached Phase III yet (Halliday 2011). Therapeutic vaccination against hepatitis C has also been explored (Klade 2008, Wedemeyer 2009, Torresi 2011). These studies show that induction of HCV-specific humoral or cellular immune responses is possible even in chronically infected individuals. The first studies showed a modest antiviral efficacy of HCV vaccination in some patients (Sallberg 2009, Habersetzer 2011, Wedemeyer 2011). Therapeutic vaccination was also able to enhance responses to interferon  $\alpha$  and ribavirin treatment (Pockros 2010, Wedemeyer 2011). Future studies will need to explore the potential role of HCV vaccines in combination with direct acting antivirals against hepatitis C.

## Vaccination against hepatitis E

A Phase II vaccine trial performed in Nepal with 200 soldiers showed a vaccine efficacy of 95% for an HEV recombinant protein (Shrestha 2007). However, the development of this vaccine has been stopped. Since then, in September 2010, data from a very large Phase III trial were reported involving about 110,000 individuals in China (Zhu 2010). The vaccine efficacy of HEV 239 was 100% after three doses to prevent cases of symptomatic acute hepatitis E. However, it is currently unknown if this HEV genotype 1 vaccine also prevents against zoonotic HEV genotype 3 infections. Moreover, vaccine efficacy in special risk groups such patients with end-stage liver disease, immunocompromised individuals or elderly persons is unknown. Finally, the duration of protection needs to be determined (Wedemeyer 2011). It is currently unknown if and when the Chinese vaccine HEV-239 will become available in other countries. Until then, preventive hygienic measures remain the only option to avoid HEV infection.

## References

- Ascherio A, Zhang SM, Hernan MA, Olek MJ, Coplan PM, Brodovicz K, Walker AM. Hepatitis B vaccination and the risk of multiple sclerosis. *N Engl J Med* 2001;344:327-32. ([Abstract](#))
- Bovier PA, Bock J, Ebengo TF, et al. Predicted 30-Year Protection After Vaccination With an Aluminum-Free Viroosomal Hepatitis A Vaccine. *Journal of Medical Virology* 2010;82:1629-34. ([Abstract](#))
- Chang MH, Chen CJ, Lai MS, et al. Universal hepatitis B vaccination in Taiwan and the incidence of hepatocellular carcinoma in children. Taiwan Childhood Hepatoma Study Group. *N Engl J Med* 1997;336:1855-9. ([Abstract](#))
- Coates T, Wilson R, Patrick G, Andre F, Watson V. Hepatitis B vaccines: assessment of the seroprotective efficacy of two recombinant DNA vaccines. *Clin Ther* 2001;23: 392-403. ([Abstract](#))

- Confavreux C, Suissa S, Saddier P, Bourdes V, Vukusic S. Vaccinations and the risk of relapse in multiple sclerosis. Vaccines in Multiple Sclerosis Study Group. *N Engl J Med* 2001;344:319-26. ([Abstract](#))
- Corey K.E, Ross A.S, Wurcel A, Schulze Zur W.J, Kim A.Y, Lauer G.M, Chung R.T. Outcomes and treatment of acute hepatitis C virus infection in a United States population. *Clin Gastroenterol Hepatol* 2006;4:1278-82. ([Abstract](#))
- Cornberg M, Protzer U, Petersen J, et al. Prophylaxis, Diagnosis and Therapy of Hepatitis B Virus Infection - The German Guideline. *Zeitschrift Fur Gastroenterologie* 2011;49:871-930.
- Deterding K, Tegtmeier B, Cornberg M, et al. Hepatitis A virus infection suppresses hepatitis C virus replication and may lead to clearance of HCV. *J Hepatol* 2006;45:770-8. ([Abstract](#))
- Deterding K, Wiegand J, Gruner N, Wedemeyer H. Medical procedures as a risk factor for HCV infection in developed countries: Do we neglect a significant problem in medical care? *J Hepatol* 2008;48:1019-20. ([Abstract](#))
- Deterding K, Wiegand J, Gruner N, et al. The German Hep-Net acute hepatitis C cohort: impact of viral and host factors on the initial presentation of acute hepatitis C virus infection. *Z Gastroenterol* 2009;47:531-40. ([Abstract](#))
- EASL Clinical Practice Guidelines: Management of hepatitis C virus infection. *J Hepatol* 2011;55:245-64.
- European Association For The Study Of The Liver (2008). EASL Clinical Practice Guidelines: Management of chronic hepatitis B. *J Hepatol* 2009. ([Abstract](#))
- European Paediatric Hepatitis C Virus Network. Effects of mode of delivery and infant feeding on the risk of mother-to-child transmission of hepatitis C virus. *BJOG* 2001;108:371-7. ([Abstract](#))
- European Paediatric Hepatitis C Virus Network. A significant sex--but not elective cesarean section--effect on mother-to-child transmission of hepatitis C virus infection. *J Infect Dis* 2005;192:1872-9. ([Abstract](#))
- Fox J, Nastouli E, Thomson E, Muir D, McClure M, Weber J, Fidler S. Increasing incidence of acute hepatitis C in individuals diagnosed with primary HIV in the United Kingdom. *AIDS* 2008;22:666-8. ([Abstract](#))
- Geier MR, Geier DA. Immunologic reactions and hepatitis B vaccine. *Ann Intern Med* 2001;134:1155. ([Abstract](#))
- Girard M. Autoimmune hazards of hepatitis B vaccine. *Autoimmun Rev* 2005;4:96-100. ([Abstract](#))
- Gordon FT, Chung RT, Curry MP, et al. Molrine Monoclonal Antibody MBL-HCV1 Suppresses Return of HCV Following Liver Transplantation. *Hepatology* 2011.
- Habersetzer F, Honnet G, Bain C, et al. A Poxvirus Vaccine Is Safe, Induces T-Cell Responses, and Decreases Viral Load in Patients With Chronic Hepatitis C. *Gastroenterology* 2011;141:890-9. ([Abstract](#))
- Halliday J, Klenerman P, Barnes E. Vaccination for hepatitis C virus: closing in on an evasive target. *Expert Review of Vaccines* 2011;10:659-72. ([Abstract](#))
- Hammit LL, Bulkow L, Hennessy TW, Zanis C, Snowball M, Williams JL, et al. Persistence of antibody to hepatitis A virus 10 years after vaccination among children and adults. *J Infect Dis* 2008;198:1776-82. ([Abstract](#))
- Han GR, Cao MK, Zhao W, et al. A prospective and open-label study for the efficacy and safety of telbivudine in pregnancy for the prevention of perinatal transmission of hepatitis B virus infection. *J Hepatol* 2011;55:1215-21. ([Abstract](#))
- Hendrickx G, Van Herck K, Vorsters A, et al. Has the time come to control hepatitis A globally? Matching prevention to the changing epidemiology. *J Viral Hepat* 2008;15 Suppl 2:1-15. ([Abstract](#))
- Hernan MA, Jick SS, Olek MJ, Jick H. Recombinant hepatitis B vaccine and the risk of multiple sclerosis: a prospective study. *Neurology* 2004;63:838-42. ([Abstract](#))
- Hollinger FB, Bell B, Levy-Bruhl D, Shouval D, Wiersma S, Van Damme P. Hepatitis A and B vaccination and public health. *J Viral Hepat* 2007;14 Suppl 1:1-5. ([Abstract](#))
- Kallinowski B, Jilg W, Buchholz L, Stremmel W, Engler S. Immunogenicity of an accelerated vaccination regime with a combined hepatitis a/b vaccine in patients with chronic hepatitis C. *Z Gastroenterol* 2003;41:983-90. ([Abstract](#))
- Kamar N, Selves J, Mansuy JM, et al. Hepatitis E virus and chronic hepatitis in organ-transplant recipients. *N Engl J Med* 2008;358:811-17. ([Abstract](#))

- Keeffe EB, Iwarson S, McMahon BJ, et al. Safety and immunogenicity of hepatitis A vaccine in patients with chronic liver disease. *Hepatology* 1998;27:881-6. (Abstract)
- Klade CS, Wedemeyer H, Berg T, et al. Therapeutic vaccination of chronic hepatitis C nonresponder patients with the peptide vaccine IC41. *Gastroenterology* 2008;134:1385-95. (Abstract)
- Kubitschke A, Bader C, Tillmann H, L Manns M, P Kuhn S, Wedemeyer H. Injury with HCV-contaminated needles: What is the true rate of serconversion? *Internist (Berl)* 2007;48: 1165-72. (Abstract)
- Lalazar G, Rund D, Shouval D. Screening, prevention and treatment of viral hepatitis B reactivation in patients with haematological malignancies. *Br J Haematol* 2007;136:699-712. (Abstract)
- Loomba R, Rowley A, Wesley R, Liang TJ, et al. Systematic review: The effect of preventive lamivudine on hepatitis B reactivation during chemotherapy. *Ann Intern Med* 2008;148:519-28. (Abstract)
- Low E, Vogel M, Rockstroh J, Nelson M. Acute Hepatitis C in HIV-Positive Individuals. *AIDS Rev* 2008;10:245-53.
- Martinez-Bauer E, Fornis X, Armelles M, et al. Hospital admission is a relevant source of hepatitis C virus acquisition in Spain. *J Hepatol* 2008;48:20-7. (Abstract)
- Monteyne P, Andre FE. Is there a causal link between hepatitis B vaccination and multiple sclerosis? *Vaccine* 2000;18:1994-2001. (Abstract)
- Nothdurft H.D. Hepatitis A vaccines. *Expert Rev Vaccines* 2008;7:535-45. (Abstract)
- Pestka JM, Zeisel MB, Blaser E, et al. Rapid induction of virus-neutralizing antibodies and viral clearance in a single-source outbreak of hepatitis C. *Proc Natl Acad Sci U S A* 2007;104:6025-30. (Abstract)
- Petersen J. HBV treatment and pregnancy. *J Hepatol* 2011;55:1171-3. (Abstract)
- Pischke S, Suneetha PV, Baechlein C, et al. Hepatitis E Virus Infection as a Cause of Graft Hepatitis in Liver Transplant Recipients. *Liver Transplantation* 2010;16:74-82. (Abstract)
- Pockros P, Jacobson I, Boyer TD, et al. Gi-5005 Therapeutic Vaccine Plus Peg-Ifn/Ribavirin Improves Sustained Virologic Response Versus Peg-Ifn/Ribavirin in Prior Non-Responders with Genotype 1 Chronic Hcv Infection. *Hepatology* 2010;52:404a-5a.
- Ranger-Rogez S, Denis F. Hepatitis B mother-to-child transmission. *Expert Rev Anti Infect Ther* 2004;2:133-45. (Abstract)
- Rehermann B. Hepatitis C virus versus innate and adaptive immune responses: a tale of coevolution and coexistence. *Journal of Clinical Investigation* 2009;119:1745-54. (Abstract)
- Rein DB, Weinbaum CM. The cost-effectiveness of using hepatitis A/B combined vaccine versus hepatitis B vaccine alone for high-risk heterosexuals. *Vaccine* 2008;26:5331-3. (Abstract)
- Sadovnick AD, Scheifele DW. School-based hepatitis B vaccination programme and adolescent multiple sclerosis. *Lancet* 2000;355:549-50. (Abstract)
- Sallberg MM, Frelin L, Diepolder H, et al. A First Clinical Trial of Therapeutic Vaccination Using Naked DNA Delivered by in Vivo Electroporation Shows Antiviral Effects in Patients with Chronic Hepatitis C. *Journal of Hepatology* 2009;50:S18-S19.
- Santantonio T, Medda E, Ferrari C, et al. Risk factors and outcome among a large patient cohort with community-acquired acute hepatitis C in Italy. *Clin Infect Dis* 2006;43:1154-9. (Abstract)
- Schattner A. Consequence or coincidence? The occurrence, pathogenesis and significance of autoimmune manifestations after viral vaccines. *Vaccine* 2005;23:3876-86. (Abstract)
- Shrestha M.P, Scott R.M, Joshi D.M, et al. Safety and efficacy of a recombinant hepatitis E vaccine. *N Engl J Med* 2007;356:895-903. (Abstract)
- Torresi J, Johnson D, Wedemeyer H. Progress in the development of preventative and therapeutic vaccines for hepatitis C virus. *J Hepatology* 2011. (Abstract)
- Turner J.M, Rider A.T, Imrie J, Copas A.J, Edwards S.G, Dodds J.P, Stephenson J.M. Behavioural predictors of subsequent hepatitis C diagnosis in a UK clinic sample of HIV positive men who have sex with men. *Sex Transm Infect* 2006;82:298-300. (Abstract)
- van de Laar T, Pybus O, Bruisten S, et al. Evidence of a large, international network of HCV transmission in HIV-positive men who have sex with men. *Gastroenterology* 2009;136:1609-17. (Abstract)

## 118 Hepatology 2012

- van der Sande MA, Waight PA, Mendy M, et al. Long-term protection against HBV chronic carriage of Gambian adolescents vaccinated in infancy and immune response in HBV booster trial in adolescence. *PLoS ONE* 2007;2: e753. ([Abstract](#))
- Van Herck K, Jacquet JM, Van Damme P. Antibody Persistence and Immune Memory in Healthy Adults Following Vaccination With a Two-Dose Inactivated Hepatitis A Vaccine: Long-Term Follow-Up at 15 Years. *J Med Virol* 2011;83:1885-91. ([Abstract](#))
- Vento S, Garofano T, Renzini C, Cainelli F, Casali F, Ghironzi G, et al. Fulminant hepatitis associated with hepatitis A virus superinfection in patients with chronic hepatitis C. *N Engl J Med* 1998;338:286-90. ([Abstract](#))
- Wedemeyer H, Cornberg M, Protzer U, Berg T, Dollinger MM. [German guidelines on diagnosis and therapy of hepatitis B]. *Dtsch Med Wochenschr* 2007;132:1775-82.
- Wedemeyer H, Pethig K, Wagner D, et al. Long-term outcome of chronic hepatitis B in heart transplant recipients. *Transplantation* 1998;66:1347-53. ([Abstract](#))
- Wedemeyer H, Schuller E, Schlaphoff V, et al. Therapeutic vaccine IC41 as late add-on to standard treatment in patients with chronic hepatitis C. *Vaccine* 2009;27:5142-51. ([Abstract](#))
- Wedemeyer H, Janczewska-Kazek E, Mazur WW, et al. HCVac study: Antiviral activity of TG4040 therapeutic vaccine in genotype-1 chronic HCV patients. *Hepatology* 2011.
- Wedemeyer H, Pischke S. Hepatitis: Hepatitis E vaccination--is HEV 239 the breakthrough? *Nat Rev Gastroenterol Hepatol* 2011;8:8-10. ([Abstract](#))
- WHO, Revised WHO position paper on hepatitis B vaccine, Oct 2009, <http://www.who.int/immunization/documents/positionpapers/en/index.html#hepb>, accessed 2011. ([Abstract](#))
- Wiegand J, Cornberg M, Aslan N, et al. Fate and function of hepatitis-C-virus-specific T-cells during peginterferon-alpha 2b therapy for acute hepatitis C. *Antivir Ther* 2007;12:303-16. ([Abstract](#))
- Wichmann O, Schimanski S, Koch J, Kohler M, Rothe C, Plentz A, et al. Phylogenetic and case-control study on hepatitis E virus infection in Germany. *J Infect Dis* 2008;198:1732-41. ([Abstract](#))
- Wolters B, Junge U, Dziuba S, Roggendorf M. Immunogenicity of combined hepatitis A and B vaccine in elderly persons. *Vaccine* 2003;21:3623-28. ([Abstract](#))
- Zanetti AR, Mariano A, Romano L, et al. Long-term immunogenicity of hepatitis B vaccination and policy for booster: an Italian multicentre study. *Lancet* 2005;366:1379-84. ([Abstract](#))
- Zhu FC, Zhang J, Zhang XF, et al. Efficacy and safety of a recombinant hepatitis E vaccine in healthy adults: a large-scale, randomised, double-blind placebo-controlled, phase 3 trial. *Lancet* 2010;376:895-902. ([Abstract](#))
- Zuckerman J, van Hattum J, Cafferkey M, Gjorup I, Hoel T, Rummukainen M.L, Weiland O. Should hepatitis B vaccination be introduced into childhood immunisation programmes in northern Europe? *Lancet Infect Dis* 2007;7:410-19. ([Abstract](#))

## 8. Hepatitis B: Diagnostic Tests

*Jörg Petersen*

### Introduction

The diagnosis of hepatitis B virus (HBV) infection was initiated by the discovery of Australia antigen (hepatitis B surface antigen, HBsAg). During the following decades, serologic assays were established for HBsAg and other HBV antigens and antibodies. Advances in molecular biology techniques led to the development of polymerase chain reaction (PCR) assays for direct determination of hepatitis B virus DNA (HBV DNA).

Diagnosis of Hepatitis B Virus (HBV) infection tests for a series of serological markers of HBV and excludes alternative etiological agents such as hepatitis A, C, and D viruses. Serological tests are used to distinguish acute, self-limited infections from chronic HBV infections and to monitor vaccine-induced immunity. These tests are also performed to determine if the patient should be considered for antiviral therapy. Nucleic acid testing for HBV DNA is used as the standard to quantify HBV viral load and measure the effectiveness of therapeutic agents.

Other causes of chronic liver disease should be systematically looked for including coinfection with HCV, HDV or HIV. Cytomegalovirus, Epstein-Barr virus, enteroviruses, other hepatotoxic drugs, and even herbal medicines should be considered when appropriate. Moreover, co-morbidities, including alcoholic, autoimmune, metabolic liver disease with steatosis or steatohepatitis should be assessed. Finally, vaccination status and previous tests results should be used to guide appropriate testing.

### Serological tests for HBV

#### Collection and transport

Serological tests for viral antigens can be performed on either serum or plasma (Yang 2002). The World Health Organization (WHO) has defined an international standard for normalisation of expression of HBV DNA concentrations (Quint 1990). Serum HBV DNA levels should be expressed in IU/ml to ensure comparability; the same assay should be used in the same patient to evaluate antiviral efficacy. Both HBV antigens and antibody are stable at room temperature for days, at 4°C for months, and frozen at -20°C to -70°C for many years. Because current testing

involves automated enzyme immunoassays that depend on colourimetric or chemiluminescence signal measurement, care should be taken to avoid hemolysis of the sample because it may interfere with the ability of the assay to accurately detect these markers. Care must be taken to avoid the degradation of the viral nucleic acid in the specimen, which can result in falsely low or no measurable viral load. Serum should therefore be removed from clotted blood within 4 hrs of collection and stored at  $-20^{\circ}\text{C}$  to  $-70^{\circ}\text{C}$  (Krayden 1998). Alternatively, the presence of EDTA in plasma is known to stabilize viral nucleic acids. EDTA blood can be stored for up to five days at  $4^{\circ}\text{C}$  without affecting the viral load. Polymerase chain reaction-based tests that are routinely used as standard can use either serum or plasma. The diagnosis of HBV infection can also be made by the detection of HBsAg or hepatitis B core antigen (HBcAg) in liver tissues by immunohistochemical staining and of HBV DNA by Southern hybridization, *in situ* hybridisation, or PCR.

### **Hepatitis B surface antigen and antibody**

Hepatitis B surface antigen (HBsAg) is the serologic hallmark of HBV infection. It can be detected by radioimmunoassays (RIA) or enzyme immunoassays (EIA). HBsAg appears in serum 1 to 10 weeks after acute exposure to HBV, prior to the onset of hepatitis and elevation of serum alanine aminotransferase. HBsAg usually becomes undetectable after four to six months in patients who recover from hepatitis B. Persistence of HBsAg for more than six months implies chronic infection. It is estimated that about 5 percent of immunocompetent adult patients with genuine acute hepatitis B progress to chronic infection (Chu 1989). Among patients with chronic HBV infection, the rate of clearance of HBsAg is approximately 0.5 to 1 percent per year (Liaw 1991). The disappearance of HBsAg is followed by the appearance of hepatitis B surface antibody (anti-HBs). In most patients, anti-HBs persists for life, thereby conferring long-term immunity. Coexistence of HBsAg and anti-HBs has been reported in HBsAg positive individuals (Tsang 1986, Dufour 2000). In most instances, the antibodies are unable to neutralize the circulating virions. These individuals should therefore be regarded as carriers of the hepatitis B virus.

In recent years the quantification of HBsAg levels (qHBsAg) has been used to determine threshold levels to distinguish between patients with active hepatitis B and inactive carrier state (Brunetto 2010). Furthermore, a continuous decline of qHBsAg during IFN  $\alpha$  therapy has been used as a response marker of therapy (Marcellin 2009). In contrast, in patients with nucleos(t)ide therapy the measurement of qHBsAg levels over time have not yielded definite answers yet in helping to distinguish patients that will clinically resolve chronic hepatitis B infection with HBsAg loss or seroconversion.

### **Hepatitis B core antigen and antibody**

Hepatitis B core antigen (HBcAg) is an intracellular antigen that is expressed in infected hepatocytes. It is not detectable in serum. Anti-HBc can be detected throughout the course of HBV infection in the serum.

During acute infection, anti-HBc is predominantly of IgM class. IgM anti-HBc is the important marker of HBV infection during the window period between the disappearance of HBsAg and the appearance of anti-HBs. IgM anti-HBc may remain detectable up to two years after acute infection. Furthermore, the titer of IgM



anti-HBc may increase to detectable levels during exacerbations of chronic hepatitis B (Maruyama 1994). This can present a diagnostic problem, incorrectly suggesting acute hepatitis B. Other common causes of acute exacerbation of chronic hepatitis B are superinfection with hepatitis D virus (delta virus) or hepatitis C virus. IgG anti-HBc persists along with anti-HBs in patients who recover from acute hepatitis B. It also persists in association with HBsAg in those who progress to chronic HBV infection.

Isolated detection of anti-HBc can occur in three settings: during the window period of acute hepatitis B when the anti-HBc is predominantly IgM; many years after recovery from acute hepatitis B when anti-HBs has fallen to undetectable levels; and after many years of chronic HBV infection when the HBsAg titer has decreased to below the level of detection. HBV DNA can be detected in the liver of most persons with isolated anti-HBc. Transmission of HBV infection has been reported from blood and organ donors with isolated anti-HBc. There are, in a small percentage of cases, false-positive isolated anti-HBc test results.

The evaluation of individuals with isolated anti-HBc should include repeat testing for anti-HBc, HBsAg, anti-HBe, and anti-HBs. Those who remain isolated anti-HBc positive should be tested for the presence of IgM anti-HBc to rule out recent HBV infection. Individuals with evidence of chronic liver disease should be tested for HBV DNA to exclude low-level chronic HBV infection.

## Hepatitis B e antigen and antibody

Hepatitis B e antigen (HBeAg) is a secretory protein processed from the precore protein. It is generally considered to be a marker of HBV replication and infectivity. The presence of HBeAg is usually associated with high levels of HBV DNA in serum and higher rates of transmission of HBV infection. HBeAg to anti-HBe seroconversion occurs early in patients with acute infection, prior to HBsAg to anti-HBs seroconversion. However, HBeAg seroconversion may be delayed for years to decades in patients with chronic HBV infection. In such patients, the presence of HBeAg is usually associated with the detection of high levels of HBV DNA in serum and active liver disease. However, HBeAg-positive patients with perinatally acquired HBV infection may have normal serum ALT concentrations and minimal inflammation in the liver (Chang 1988).

Seroconversion from HBeAg to anti-HBe is usually associated with a decrease in serum HBV DNA and remission of liver disease. However, some patients continue to have active liver disease after HBeAg seroconversion. Such individuals may have low levels of wild type HBV or HBV variants with a stop codon in the precore or dual nucleotide substitutions in the core promoter region that prevent or decrease the production of HBeAg (Carman 1989).

## Serum HBV DNA assays

Qualitative and quantitative tests for HBV DNA in serum have been developed to assess HBV replication. Currently, most HBV DNA assays use real-time PCR techniques, report results in IU/mL, have a lower limit of detection of around 20 IU/mL and a range of linearity up to  $8 \log_{10}$  IU/mL.

Recovery from acute hepatitis B is usually accompanied by the disappearance of HBV DNA in serum. However, HBV DNA may remain detectable in serum for

many years if tested by PCR assays (Cornberg 2011) suggesting that the virus persists but is controlled by the immune system.

In patients with spontaneous or treatment-induced HBeAg seroconversion in chronic hepatitis B, PCR assays usually remain positive except in patients with HBsAg seroconversion. By contrast, most patients who develop HBeAg seroconversion during nucleos(t)ide analog therapy have undetectable serum HBV DNA. In fact, many patients receiving nucleos(t)ide analog therapy remain HBeAg positive despite having undetectable serum HBV DNA for months or years. The explanation for this phenomenon is unclear but is likely related to the lack of direct effect of nucleos(t)ide analogs on covalently closed circular HBV DNA (ccc DNA) and viral RNA transcription and viral protein expression.

HBV DNA levels are also detectable in patients with HBeAg negative chronic hepatitis, although levels are generally lower than in patients with HBeAg positive chronic hepatitis. Because of the fluctuations in HBV DNA levels there is no absolute cutoff level that is reliable for differentiating patients in the inactive carrier state from those with HBeAg negative chronic hepatitis B (Chu 2002).

## HBV genotypes

HBV can be classified into eight genotypes and four major serotypes. There have been reports about differing therapeutic responses with nucleos(t)ide analogs and interferon  $\alpha$  with respect to different genotypes. Furthermore, some genotypes, such as B and C, may have a greater risk for the development of hepatocellular carcinomas. Nevertheless, in the clinical setting in contrast to hepatitis C, the diagnosis of HBV genotypes is not part of clinical routine (Thursz 2011).

## Antiviral resistance testing

Drug-resistant hepatitis B virus (HBV) mutants frequently arise, leading sometimes to treatment failure and progression to liver disease. There has been much research time invested into the mechanisms of resistance to nucleos(t)ides and the selection of mutants. The genes that encode the polymerase and envelope proteins of HBV overlap, so resistance mutations in the polymerase usually affect the hepatitis B surface antigen; these alterations affect infectivity, vaccine efficacy, pathogenesis of liver disease, and transmission throughout the population (see Chapter 2). Associations between HBV genotype and resistance phenotype have allowed cross-resistance profiles to be determined for many commonly detected mutants, so genotyping assays can be used to adapt therapy. *In vitro* phenotyping procedures are established in a rather small number of HBV laboratories and are not commercially available. Known mutations can be detected by commercially available tests with a threshold of about 5% (line probe assays, Inno-Lipa<sup>®</sup>) whereas determination of novel mutations remain to be detected by research oriented laboratories with full length sequencing methods. Novel ultra-deep pyrosequencing techniques are much more sensitive in order to detect many more viral variants but are a tool only for specialised research laboratories and not part of clinical routine (Zoulim 2009, Margeridon-Thermet 2009).

## Assessment of liver disease

As a first step, the causal relationship between HBV infection and liver disease has to be established and an assessment of the severity of liver disease needs to be performed. Not all patients with chronic hepatitis B virus infection have persistently elevated aminotransferases. Patients in the immune tolerant phase have persistently normal ALT levels and a proportion of patients with HBeAg-negative chronic hepatitis B may have intermittently normal ALT levels. Therefore appropriate, longitudinal long-term follow-up is crucial.

The assessment of the severity of liver disease should include: biochemical markers, including aspartate aminotransferase (AST) and ALT, gamma-glutamyl transpeptidase (GGT), alkaline phosphatase, prothrombin time and serum albumin; blood counts; and hepatic ultrasound. Usually, ALT levels are higher than AST. However, when the disease progresses to cirrhosis, the ratio may be reversed. A progressive decline in serum albumin concentrations and prolongation of the prothrombin time, often accompanied by a drop in platelet counts, are characteristically observed once cirrhosis has developed (EASL 2009).

### Acute HBV infection

The diagnosis of acute hepatitis B is based upon the detection of HBsAg and IgM anti-HBc. During the initial phase of infection, markers of HBV replication, HBeAg and HBV DNA, are also present. Recovery is accompanied by the disappearance of HBV DNA, HBeAg to anti-HBe seroconversion, and subsequently HBsAg to anti-HBs seroconversion.

The differential diagnosis of HBsAg-positive acute hepatitis includes acute hepatitis B, exacerbations of chronic hepatitis B, reactivation of chronic hepatitis B, superinfection of a hepatitis B carrier with hepatitis C or D virus (Tassopoulos 1987), and acute hepatitis due to drugs or other toxins in a hepatitis B carrier.

### Past HBV infection

Previous HBV infection is characterized by the presence of anti-HBs and IgG anti-HBc. Immunity to HBV infection after vaccination is indicated by the presence of anti-HBs only.

#### HBsAg

- If negative, acute HBV infection is ruled out (Dufour 2000).
- If positive, the patient is infected with HBV. A repeat test six months later will determine if the infection has resolved or is chronic.

#### Anti-HBs

- If negative, the patient has no apparent immunity to HBV
- If positive, the patient is considered immune to HBV (either because of resolved infection or vaccination).

### Anti-HBc-immunoglobulin M

In rare cases, anti-HBc immunoglobulin (Ig) M may be the only HBV marker detected during the early convalescence or 'window period' when the HBsAg and anti-HBs tests are negative. Because current tests for HBsAg are very sensitive, an anti-HBc IgM that is typically positive with acute HBV infection is not generally

required to diagnose active infection. Because some chronic HBV carriers remain anti-HBc IgM positive for years, epidemiological information is necessary to confirm that the infection is indeed acute. A negative anti-HBc IgM in the presence of a positive HBsAg suggests that the infection is likely chronic. For these reasons, routine testing for anti-HBc IgM is not generally recommended to screen for acutely infected patients.

## Chronic HBV infection

Chronic HBV infection is defined by the continued presence of HBsAg in the blood for longer than six months. Additional tests for HBV replication, HBeAg and serum HBV DNA, should be performed to determine if the patient should be considered for antiviral therapy. All patients with chronic HBV infection should be regularly monitored because HBV DNA and ALT levels vary during the course of infection to monitor for progression of liver disease. In addition, patients who are not candidates for treatment at the time of presentation may become candidates for treatment during follow-up.

HBeAg-negative patients who have normal serum ALT and low (<2000 IU/mL) or undetectable HBV DNA are considered to be in an inactive carrier state. These patients generally have a good prognosis and antiviral treatment is not indicated. However, serial tests are necessary to accurately differentiate them from patients with HBeAg-negative chronic hepatitis who have fluctuating ALT and/or HBV DNA levels (Lok 2007). Patients who are truly inactive carriers should continue to be monitored but at less frequent intervals. HBeAg-negative patients with elevated serum ALT concentrations should be tested for serum HBV DNA to determine if the liver disease is related to persistent HBV replication.

### HBsAg

- If negative, chronic HBV infection is typically ruled out.
- If positive, the patient is considered HBV-infected. Chronic infection is diagnosed when the HBsAg remains detectable for longer than six months.

### Antibody to hepatitis B core protein

- If negative, past infection with HBV is typically ruled out.
- If positive, the patient has been infected with HBV. Infection may be resolved (HBsAg-negative) or ongoing (HBsAg-positive). If the infection is resolved, the person is considered naturally immune to HBV infection.

### Antibody to hepatitis B surface protein

- If negative, the patient has no apparent immunity to HBV
- If positive, the patient is considered immune to HBV (either because of resolved infection or as the result of prior vaccination). Very rarely (less than 1%) chronic carriers can be positive for HBsAg and antibody to hepatitis B surface protein (anti-HBs) at the same time (Tsang 1986, Dufour 2000). In such cases, the patient is considered infectious.

## Serum transaminases

Once an individual has been diagnosed with chronic HBV infection, follow-up testing must be performed for alanine aminotransferase (ALT), a marker of liver cell

inflammation. Repeat periodic testing is indicated because the ALT levels can fluctuate (e.g., from less than the upper limit of normal to intermittently or consistently elevated). Sustained and intermittent elevations in ALT beyond the upper limit of normal are indicative of hepatic inflammation and correlate with an increased risk of progressive liver disease. It must be noted that the normal ALT ranges are both age and sex dependent and, occasionally, individuals with severe liver disease may not manifest elevated ALT (Cornberg 2011, EASL 2009).

## Occult HBV infection

This is defined as the presence of detectable HBV DNA by PCR in patients who are negative for HBsAg. Most of these patients have very low or undetectable serum HBV DNA levels accounting for the failure to detect HBsAg. Infections with HBV variants that decrease HBsAg production or have mutations in the S gene with altered S epitopes that evade detection in serology assays for HBsAg are uncommon. HBV DNA is often detected in the liver and transplantation of livers from these persons can result in *de novo* HBV infection (Margeridon-Thermet 2009).

## Assessment of HBV immunity

Immunity to HBV is acquired from a resolved infection or from vaccination. The HBV vaccine has been shown to induce protective immunity in 90% to 95% of vaccinees. Most vaccinees will have protective levels of anti-HBs for 5-10 years after vaccination, although the exact duration of immunity remains undefined.

### Anti-HBs

- If the anti-HBs level is less than 10 mIU/mL, this implies that the person is nonimmune to HBV. In individuals who have received a complete course of HBV vaccine, the level of anti-HBs may drop to less than 10 mIU/mL after five to 10 years, but these individuals are generally considered to be immune based on their vaccination history (Maruyama 1994).
- If the anti-HBs result is greater than 10 mIU/mL, the person is considered to be immune. Immunity may be due to immunization or resolved natural infection. These two states can be distinguished by testing for antibody to hepatitis B core protein (anti-HBc), which is present in subjects that have had HBV infection but absent in vaccinees (see below).

### Anti-HBc

- If the anti-HBc total test is positive, this is compatible with current or resolved HBV infection. A negative HBsAg confirms a resolved infection. HBV vaccination does not induce anti-HBc total.

## Liver biopsy and noninvasive liver transient elastography

A liver biopsy is recommended for determining the degree of necroinflammation and fibrosis in patients with either increased ALT or HBV DNA levels >2000 IU/ml (or both) since hepatic morphology can assist the decision to start treatment. Biopsy is also useful for evaluating other possible causes of liver disease such as steatosis or steatohepatitis. Although liver biopsy is an invasive procedure, the risk of severe complications is low. It is important that the size of the needle biopsy specimen be

large enough to precisely analyse the degree of liver injury and fibrosis. A liver biopsy is usually not required in patients with clinical evidence of cirrhosis or in those in whom treatment is indicated irrespective of the grade of activity or the stage of fibrosis.

There is growing interest in the use of noninvasive methods, including serum markers and transient elastography, to assess hepatic fibrosis to complement or avoid a liver biopsy (Cornberg 2011, EASL 2009).

## References

- Brunetto MR, Oliveri F, Colombatto P, et al. Hepatitis B surface antigen serum levels help to distinguish active from inactive hepatitis B virus genotype D carriers. *Gastroenterology* 2010;139:483-90. ([Abstract](#))
- Carman WF, Jacyna MR, Hadziyannis S, et al. Mutation preventing formation of hepatitis B e antigen in patients with chronic hepatitis B infection. *Lancet* 1989;2:588. ([Abstract](#))
- Chang MH, Hwang LY, Hsu HC, et al. Prospective study of asymptomatic HBsAg carrier children infected in the perinatal period: clinical and liver histologic studies. *Hepatology* 1988;8:374 ([Abstract](#))
- Chu CJ, Hussain M, Lok AS. Quantitative serum HBV DNA levels during different stages of chronic hepatitis B infection. *Hepatology* 2002;36:1408. ([Abstract](#))
- Chu CM, Liaw YF, Pao CC, Huang MJ. The etiology of acute hepatitis superimposed upon previously unrecognized asymptomatic HBsAg carriers. *Hepatology* 1989;9:452. ([Abstract](#))
- Cornberg, M, Protzer U, Petersen J, et al. Aktualisierung der S3 Leitlinie zur Prophylaxe, Diagnostik und Therapie der Hepatitis-B-Virusinfektion. *Z Gastroenterol* 2011;49:871-930
- Dufour DR, Lott JA, Nolte FS, Gretch DR, Koff RS, Seeff LB. Diagnosis and monitoring of hepatic injury. I. Performance characteristics of laboratory tests. *Clin Chem* 2000;46:2027-49. ([Abstract](#))
- EASL Clinical Practice Guidelines: Management of chronic Hepatitis B. *J Hepatology* 2009;50:227-42
- Hepatitis B virus resistance to nucleos(t)ide analogues. Zoulim F, Locarnini S. *Gastroenterology* 2009;137:1593-608 ([Abstract](#))
- Krajden M, Comanor L, Rifkin O, Grigoriew A, Minor JM, Kapke GF. Assessment of hepatitis B virus DNA stability in serum. *J Clin Microbiol* 1998;36:382-6.
- Liaw YF, Sheen IS, Chen TJ, et al. Incidence, determinants and significance of delayed clearance of serum HBsAg in chronic hepatitis B virus infection: a prospective study. *Hepatology* 1991;13:627. ([Abstract](#))
- Lok AS, McMahon BJ. Chronic hepatitis B. *Hepatology* 2007;45:507. ([Abstract](#))
- Marcellin P, Bonino F, Lau GK, et al. Sustained response of hepatitis B e antigen-negative patients 3 years after treatment with peginterferon alpha-2a. *Gastroenterology* 2009;136:2169-79. ([Abstract](#))
- Margeridon-Thermet S, Shulman NS, Ahmed A, et al. Ultra-deep pyrosequencing of hepatitis B virus quasispecies from nucleoside and nucleotide reverse-transcriptase inhibitor (NRTI)-treated patients and NRTI-naïve patients. *J Infect Dis* 2009;199:1275-85 ([Abstract](#))
- Maruyama T, Schödel F, Iino S, et al. Distinguishing between acute and symptomatic chronic hepatitis B virus infection. *Gastroenterology* 1994;106:1006. ([Abstract](#))
- Quint WG, de Bruijn I, Kruining H, Heijntink RA. HBV-DNA detection by gene amplification in acute hepatitis B. *Hepatology* 1990;12:653-6. ([Abstract](#))
- Raimondo G, Allain JP, Brunetto MR, et al. Statements from the Taormina expert meeting on occult hepatitis B virus infection. *J Hepatol* 2008;49:652. ([Abstract](#))
- Tassopoulos NC, Papaevangelou GJ, Sjogren MH, et al. Natural history of acute hepatitis B surface antigen-positive hepatitis in Greek adults. *Gastroenterology* 1987;92:1844. ([Abstract](#))
- Thursz M, Yee L, Khakoo S. Understanding the host genetics of chronic hepatitis B and C. *Semin Liver Dis* 2011;31:115-127. ([Abstract](#))

- Tsang TK, Blei AT, O'Reilly DJ, Decker R. Clinical significance of concurrent hepatitis B surface antigen and antibody positivity. *Dig Dis Sci* 1986;31:620. ([Abstract](#))
- Yang HI, Lu SN, Liaw YF, et al. Hepatitis B e antigen and the risk of hepatocellular carcinoma. *N Engl J Med* 2002;347:168-74. ([Abstract](#))

## 9. Hepatitis B Treatment

*Florian van Bömmel, Johannes Wiegand, Thomas Berg*

### Introduction

Individuals with HBV infection carry a significantly increased risk of life-threatening complications such as hepatic decompensation, liver cirrhosis and hepatocellular carcinoma (HCC) (Beasley 1988). Recent studies have shown that the level of serum HBV DNA correlates higher with the risk of developing cirrhosis and HCC as compared to other baseline or virologic parameters (Chen 2006, Iloeje 2006) (Figure 1). Thus, suppressing the replication of HBV to undetectable levels is now a major goal in HBV treatment (Liaw 2008, Lok 2007, EASL 2009, Cornberg 2011). Moreover, it has now become clear that continuous suppression of HBV replication can revert liver fibrosis or even cirrhosis in most patients (Marcellin 2011, Schiff 2011). HBeAg seroconversion is another endpoint, provided that HBV replication remains durably suppressed to low levels. The ultimate treatment goal, however, the loss of HBsAg or HBsAg seroconversion, remains difficult to achieve. The level of hepatitis B surface antigen (HBsAg) before and during interferon-based treatment is becoming a marker for response to interferon based treatment.

There are two drug classes available for the treatment of chronic HBV infection: the immune modulator interferon  $\alpha$  (standard or pegylated (PEG)-INF  $\alpha$ ) and nucleoside or nucleotide analogs, which act as reverse transcriptase inhibitors of the HBV polymerase. Currently, the nucleoside analogs lamivudine (LAM), telbivudine (LdT), entecavir (ETV) and the acyclic nucleotide analogs adefovir dipivoxil (ADV) and tenofovir disoproxil fumarate (TDF) are available. Due to this broad spectrum of therapeutic options disease progression and complications can be prevented if the infection is diagnosed early and treated effectively. The early diagnosis of chronic hepatitis B by HBsAg screening in high-risk groups and in patients with elevated transaminases plays a crucial role in the management of HBV infection.

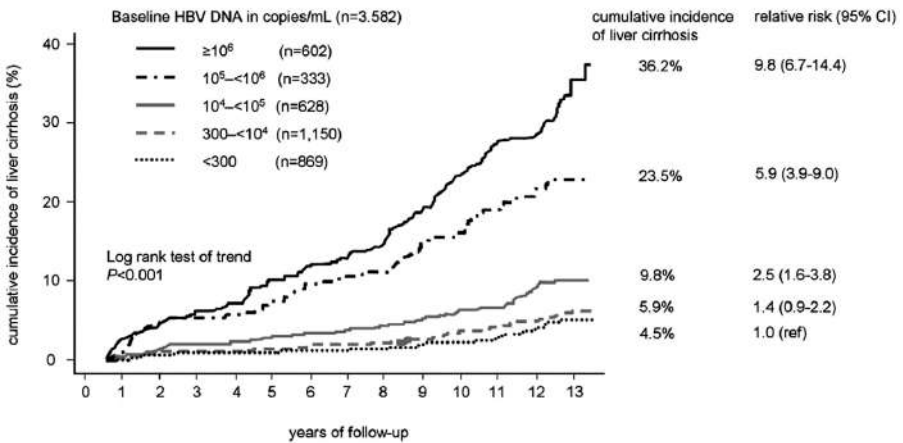
### Indication for antiviral therapy

#### Acute hepatitis B

Acute hepatitis resolves spontaneously in 95-99% of cases (McMahon 1985, Liaw 2009). Therefore, treatment with the currently available drugs is generally not



indicated. However, in a recent trial comparing treatment with LAM 100 mg/day versus no treatment in 80 Chinese patients with fulminant hepatitis B, a reduced mortality of 7.5% was found in patients receiving LAM treatment compared to 25% in the control group ( $p=0.03$ ) (Yu 2010). These observations are supported by a placebo-controlled trial investigating the use of LAM in 71 patients with fulminant hepatitis B in India (Kumar 2007). Several case reports from Europe also revealed that patients with severe and fulminate hepatitis B may benefit from early antiviral therapy with LAM or other nucleos(t)ide analogs by reducing the need for high-urgency liver transplantation (Tillmann 2006). As a result, treatment for fulminant hepatitis B with LAM is recommended by EASL and with LAM or LdT by AASLD (EASL 2009, Lok 2009). Interferon therapy is contraindicated in patients with acute HBV infection because of risk of increasing hepatitis. The endpoint of treatment of acute HBV infections is HBsAg clearance (EASL 2009, Lok 2007).



**Figure 1. Cumulative incidence of liver cirrhosis in untreated HBV-infected individuals within a mean observation period of 11.4 years (REVEAL Study).** The incidence of liver cirrhosis increases over time depending on baseline HBV DNA levels (Iloeje 2006). The relative risk for developing HCC was 1.4 in patients with HBV DNA levels of 300 to 1,000 and increased to 2.4 in patients with 1,000-10,000 to 5.4 in patients with 10,000 to 100,000 and to 6.7 in patients with HBV DNA levels  $>1$  million copies/ml. A similar association between HBV DNA levels and the risk of HCC development was shown (Chen 2006).

## Chronic hepatitis B

All patients with HBsAg positive chronic hepatitis should be considered as possible candidates for antiviral therapy especially in situations when there is a significant level of HBV replication (Chen 2006, Iloeje 2006). Differentiation between HBeAg-positive and HBeAg-negative chronic hepatitis B is not necessary anymore for treatment indication, although with respect to the choice of the appropriate antiviral drug these criteria may be still useful.

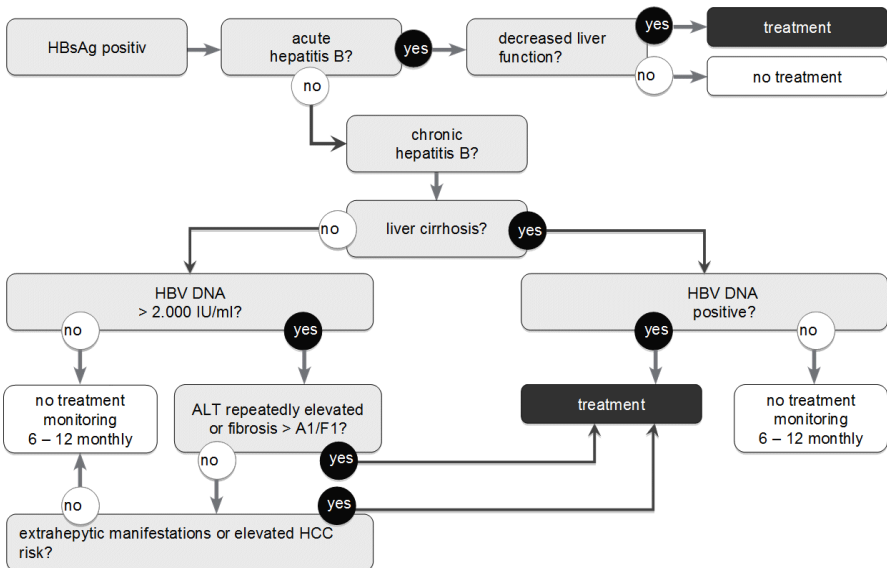
**Table 1. Key guideline recommendations for indication for antiviral treatment of HBV infection.**

AASLD (Lok 2007, Lok 2009)	<p>Consider treatment:</p> <ul style="list-style-type: none"> <li>• HBeAg(+): HBV DNA &gt;20,000 IU/ml + ALT <math>\leq</math>2x ULN + biopsy shows moderate/severe inflammation or significant fibrosis</li> <li>• HBeAg(+): HBV DNA &gt;20,000 IU/ml + ALT &gt;2x ULN. Observe for 3-6 months and treat if no spontaneous HBeAg loss</li> <li>• HBeAg(-): HBV DNA &gt;20,000 IU/ml + ALT &gt;2x ULN</li> </ul> <p>Consider biopsy:</p> <ul style="list-style-type: none"> <li>• HBeAg(+): HBV DNA &gt;20,000 IU/ml + ALT &gt;2x ULN + compensated</li> <li>• HBeAg(+): HBV DNA &gt;20,000 IU/ml + ALT 1-2x ULN + age &gt;40 years or family history of HCC</li> <li>• HBeAg(-): HBV DNA &gt;2,000-20,000 IU/ml + ALT 1-2x ULN</li> </ul>
APASL (Liaw 2008)	<p>Consider treatment:</p> <ul style="list-style-type: none"> <li>• All patients: HBV DNA detectable + advanced fibrosis/cirrhosis</li> <li>• HBeAg(+): HBV DNA &gt;20,000 IU/ml + ALT &gt;2x ULN + impending/ overt decompensation</li> <li>• HBeAg(-): HBV DNA &gt; 2,000 + ALT &gt;2x ULN + impending/ overt decompensation</li> </ul>
EASL (EASL 2009)	<p>Consider treatment:</p> <ul style="list-style-type: none"> <li>• HBV DNA &gt;20,000 IU/ml + ALT &gt;2x ULN + moderate to severe necroinflammation</li> </ul>
Belgian (Colle 2007)	<p>Consider treatment:</p> <ul style="list-style-type: none"> <li>• HBeAg(+): HBV DNA &gt;20,000 IU/ml + ALT &gt;2x ULN (or moderate/severe hepatitis on biopsy)</li> <li>• HBeAg(-): HBV DNA <math>\geq</math>2,000 IU/ml and elevated ALT</li> </ul> <p>Consider biopsy:</p> <ul style="list-style-type: none"> <li>• Fluctuating or minimally elevated ALT (especially in those older than 35-40 years)</li> </ul>
Dutch (Buster 2008)	<p>Consider treatment:</p> <ul style="list-style-type: none"> <li>• HBeAg(+) and HBeAg(-): HBV DNA <math>\geq</math>20,000 IU/ml and ALT <math>\geq</math>2x ULN or active necrotic inflammation</li> <li>• HBeAg(-): HBV DNA <math>\geq</math>2,000–20,000 IU/ml and ALT <math>\geq</math>2x ULN (and absence of any other cause of hepatitis)</li> </ul>
German (Cornberg 2011)	<p>Consider treatment:</p> <ul style="list-style-type: none"> <li>• HBV DNA &gt;2,000 IU/ml + minimal inflammation/low fibrosis or ALT elevation</li> </ul>
Italian (Carosi 2008)	<p>Consider treatment:</p> <ul style="list-style-type: none"> <li>• HBeAg(+): HBV DNA &gt;20,000 IU/ml + ALT &gt;2x ULN</li> <li>• HBeAg(-): HBV DNA &gt;2,000 IU/ml + abnormal ALT and or fibrosis (Ishak <math>\geq</math>S2)</li> </ul> <p>Consider biopsy:</p> <ul style="list-style-type: none"> <li>• HBeAg(-): HBV DNA &gt;2,000 IU/ml + borderline ALT, or if DNA 2,000–20,000 IU/ml + high ALT</li> </ul>
Turkish TASL (Akarca 2008)	<p>Consider treatment:</p> <ul style="list-style-type: none"> <li>• HBV DNA &gt;2,000 IU/ml + histological fibrosis &gt;2</li> <li>• HBV DNA &gt;20,000 IU/ml + any histological finding + ALT &gt;2x ULN</li> </ul>

Current recommendations of the different national and international societies are shown in Table 1 (Akarca 2008, Carosi 2008, Colle 2007, Cornberg 2011, EASL 2009, Janssen 2008, Juszczak 2008, Keeffe 2007, Liaw 2008, Lok 2009, Waked 2008). In most of these guidelines, the most relevant factor for a decision to initiate treatment has shifted from histological proven disease activity to the level of HBV

DNA. Thus, most of the recently published guidelines now recommend antiviral treatment for patients with HBV DNA levels  $>2,000$  IU/mL (corresponding to  $>10,000$  copies/mL) in association with a sign of ongoing hepatitis which can either be ALT levels greater than 2 times the upper limit of normal or significant fibrosis demonstrated by liver histology greater than A1/F1. The recently updated German treatment guidelines emphasise the importance of suppression of HBV replication by recommending treatment in patients with HBV DNA levels  $>2,000$  IU/mL and any elevation of ALT levels or signs of fibrosis (Cornberg 2011).

All patients with liver cirrhosis or high-grade liver fibrosis and any measurable HBV DNA should be considered for antiviral therapy (EASL 2009, Lok 2007, Cornberg 2011). The indication for antiviral treatment according to the recent German guidelines is depicted in Figure 2 (Cornberg 2011). In patients with decompensated cirrhosis Child-Pugh score B or C, INF  $\alpha$  is contraindicated.



**Figure 2. Indication for antiviral treatment according to the German guidelines for the treatment of chronic HBV infection.** Treatment should be considered if HBV DNA levels exceed  $10^4$  copies/ml and if ALT are elevated or if liver histology is abnormal. Of note, asymptomatic carriers with family history of HCC should receive treatment even if signs of hepatitis are absent (Cornberg 2011).

Inactive chronic HBsAg carriers, characterised by negative HBeAg and positive anti-HBeAg, low HBV DNA levels ( $<2,000$  IU/ml) and serum aminotransferases within normal levels do not have an indication for antiviral therapy (Cornberg 2011, Brunetto 2011). However, differentiation between inactive HBsAg carriers and patients with chronic HBeAg-negative hepatitis may be difficult in some cases. Elevated transaminases are no reliable parameter for assessing the stage of liver fibrosis and long-term prognosis of HBV-infected patients. Even in patients with normal or slightly elevated aminotransferases there can be a significant risk for the development of HBV-associated complications (Chen 2006, Iloeje 2006, Kumar 2008). It is reasonable to perform a liver biopsy in these individuals and to control

the level of HBV DNA at three-month intervals. However, a liver biopsy is not mandatory to initiate treatment for the majority of patients (Table 1).

HBV immunotolerant patients are mostly under 30 years old and can be recognised by their high HBV DNA levels, positive HBeAg, normal ALT levels and minimal or absence of significant histological changes. According to most practice guidelines immediate therapy is not required (Akarca 2007, Balik 2008, Carosi 2008, Colle 2007, Cornberg 2011, EASL 2009, Buster 2008, Juszczak 2008, Keeffe 2007, Liaw 2008, Lok 2009, Waked 2008). However, patients with elevated risk for HCC development, such as those with a positive family history, and patients from high endemic areas like Asia or Africa may perhaps benefit from early antiviral therapy (Cornberg 2011). Studies are under way to further clarify this issue, especially to answer the question whether early intervention with antiviral therapy will positively influence the long-term risk for HCC.

### Summary of treatment indications in the German Guidelines of 2011

- All patients with chronic hepatitis B should be evaluated for treatment. Indication for treatment initiation depends on the level of viral replication (HBV DNA  $\geq 2,000$  IU/mL, corresponding to ml  $\geq 10,000$  copies/mL), any elevation of serum aminotransferases and the histological grading and staging.
- Patients with advanced fibrosis or cirrhosis and detectable viremia need consistent antiviral therapy.
- Reactivation of HBV replication due to immunosuppression should be avoided by preventive therapy.
- Alcohol and drug consumption are not a contraindication for treatment with nucleos(t)ide analogs.
- Therapy with nucleos(t)ide analogs during pregnancy may be considered if the benefit outweighs the risk. A running treatment with LAM or TDF can be continued during pregnancy.
- Occupational and social aspects and extrahepatic complications may justify therapy in individual cases.

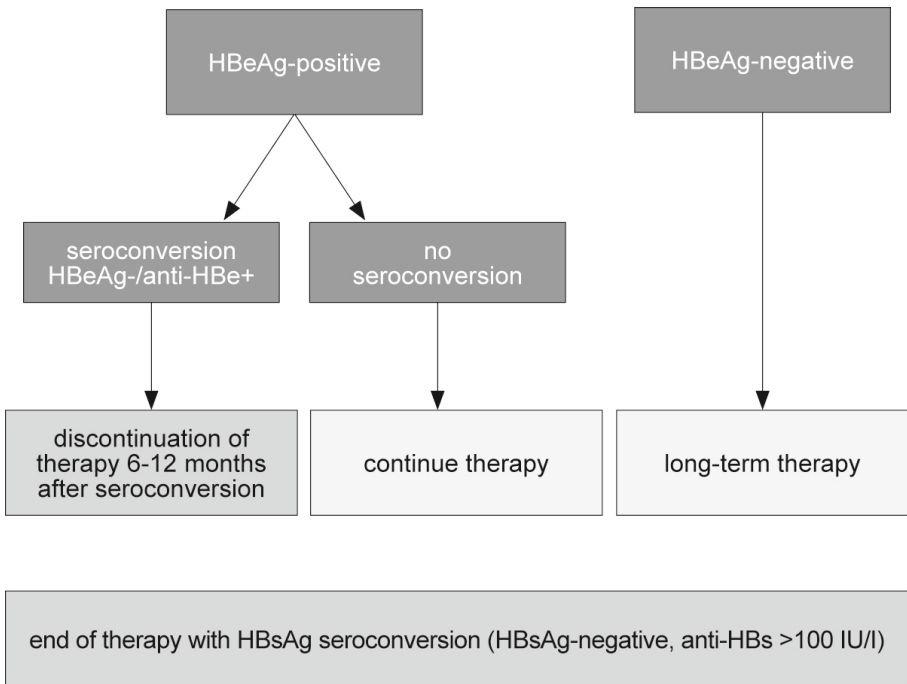
### Endpoints of antiviral treatment

Due to persistence of episomal covalently closed circular DNA (cccDNA), a template of the HBV genome located in the nucleus of infected hepatocytes, a complete eradication of HBV infection is currently impossible (Rehermann 1996). Reactivation of an HBV infection can occur in certain circumstances from these nuclear reservoirs even decades after HBsAg loss, for instance during immunosuppressive therapy. The aim of treatment of chronic hepatitis B is to reduce complications such as liver failure and HCC and to increase survival (EASL 2009, Lok 2009, Cornberg 2011). To determine the success of antiviral therapy surrogate markers are used during and after treatment. These parameters include virologic (HBeAg and HBsAg status, HBsAg levels, HBV DNA level) and patient-related parameters (aminotransferases, liver histology).

**Suppression of HBV replication.** In two recent studies a close correlation between baseline HBV DNA levels and progression of the disease was demonstrated. In the REVEAL study, 3774 untreated HBV-infected individuals were followed

over a mean time period of 11.4 years in Taiwan (Chen 2006, Iloeje 2006). HBV DNA levels at baseline were the strongest predictors of cirrhosis and HCC development (Figure 1). In multivariate models, the relative risk of cirrhosis increased when HBV DNA reached levels greater than 300 copies/mL, independent of whether patients were negative or positive for HBeAg. In addition, individuals with HBV DNA levels  $\geq 10^4$  copies/mL (or  $\geq 2,000$  IU/mL) were found to have a 3-15 fold greater incidence of HCC as compared to those with a viral load  $< 10^4$  copies/mL. According to these results, a meta-analysis covering 26 prospective studies revealed a statistically significant and consistent correlation between viral load levels and histologic, biochemical, or serologic surrogate markers (Mommeja-Marin 2003). It can therefore be concluded that the complete and persistent suppression of HBV replication is a reliable endpoint for the treatment of chronic HBV infection.

**Induction of HBeAg seroconversion.** In HBeAg-positive patients, seroconversion from HBeAg to anti-HBe was found to be a reliable surrogate marker for prognosis of chronic HBV infection leading in many cases to an inactive HBsAg carrier state (Figure 3). In these patients, HBsAg remains detectable but HBV replication continues at low or even undetectable levels and transaminases are generally within normal ranges.



**Figure 3. Possible endpoints of treatment of chronic HBV infection. After achieving HBeAg or HBsAg seroconversion, antiviral treatment can be stopped.** However, it is recommended to maintain treatment for a period of 6-12 months after HBeAg or HBsAg seroconversion.

Long-term observations reveal, however, that HBeAg seroconversion cannot always be taken as a guarantee of long-term remission. A reactivation of the disease with “seroreversion” (HBeAg becoming detectable again) as well as a transition to HBeAg-negative chronic hepatitis B with increased, often fluctuating, HBV DNA levels, can occur in up to 30% of patients (Hadziyannis 1995, Hadziyannis 2001, Hadziyannis 2006). Therefore, HBeAg seroconversion should be regarded as a stable treatment endpoint only in conjunction with durable and complete suppression of HBV replication.

In the natural course of HBV infection, the time point of HBeAg seroconversion is important regarding the probability of long-term complications. In a recent long-term observational study in 483 HBeAg-positive patients achieving spontaneous HBeAg seroconversion, it was shown that for 15 years after HBeAg seroconversion the incidence of cirrhosis and HCC was lower for patients who had achieved HBeAg seroconversion at an age <30 years old compared to patients achieving seroconversion at an age >40 years old (Chen 2010). This observation raises the question of whether HBeAg seroconversions during antiviral treatment in patients older than 40 years are also associated with a higher risk of complications compared to patients who achieve HBeAg seroconversion at a younger age.

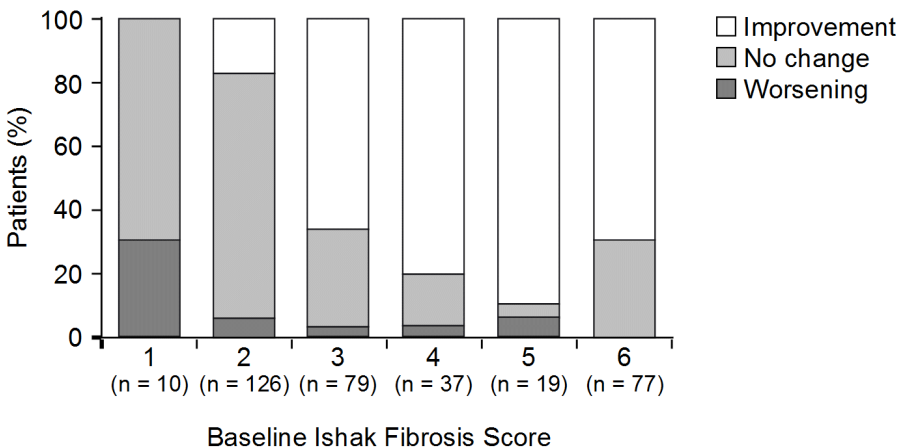
**Sustained response and “immune control”.** The endpoint of therapy for patients with HBeAg-negative disease is more difficult to assess. Long-term suppression of HBV replication and ALT normalization are the only practical parameters of response to therapy. Once antiviral therapy is stopped, durability of response is not guaranteed due to the fluctuating course of HBeAg-negative chronic hepatitis B.

For treatment with PEG-IFN  $\alpha$  in both, HBeAg-positive and -negative patients, the inducing of a so-called ‘immune control’ status, characterized by persistent suppression of viral replication with HBV DNA levels <2,000 IU/ml and normalisation of ALT levels was recently defined as another, combined treatment endpoint (Marcellin 2009). If this condition is maintained over time, it increases the probability of HBsAg loss and reduces the development of liver fibrosis and HCC. Late relapse beyond 6 months post-treatment has been described, but a sustained response at 1 year post-treatment appears to be durable through long-term follow-up (EASL 2009, Marcellin 2009). However, the immune control status needs to be regularly monitored, and treatment needs to be re-introduced in case of increase of HBV replication. For patients presenting any signs of liver fibrosis or family history of HCC, immune control should not be regarded as the treatment endpoint but rather the complete suppression of HBV replication.

**Induction of HBsAg loss.** The ultimate goal of antiviral treatment is HBsAg loss or even seroconversion to anti-HBs. Because HBsAg loss or seroconversion is associated with a complete and definitive remission of the activity of chronic hepatitis B and an improved long-term outcome, it is regarded as a cure from chronic hepatitis B. However, HBsAg loss or seroconversion can be induced in only a limited number of patients after short-term treatment (<5%). Interestingly, in recent follow-up studies in PEG-INF  $\alpha$  as well as nucleoside/nucleotide analog treated patients an increase of the rates of HBsAg loss during long-term studies was shown (Marcellin 2009, Marcellin 2011). However, as the probability of HBsAg seroclearance during therapy with nucleoside or nucleotide analogs is linked to the decrease of HBsAg levels during the early treatment period, it seems questionable

if after a treatment duration of 4-5 years significantly higher rates of HBsAg loss can be expected (Marcellin 2011).

**Reversion of liver fibrosis.** With long-term treatment with different nucleoside and nucleotide analogs it has been demonstrated that liver fibrosis and even cirrhosis can be reverted in the majority of patients. This was recently impressively shown in a subgroup of 59 patients from a rollover study including two Phase III trials of the efficacy of ETV in treatment-naïve patients. Liver biopsies from baseline and after a median treatment duration of 6 years (range, 3-7 years) found an histologic improvement, defined as a decrease of 2 points or greater in the Knodell necroinflammatory score in absence of worsening of the Knodell fibrosis score, in 96% of patients. In addition, an improvement of more than 1 point in the Ishak fibrosis score was seen in 88%, including all 10 patients who had advanced fibrosis or cirrhosis when they entered the Phase 3 studies (Chang 2010a). More recently, in a subanalysis of the tenofovir Trials 102 and 103 evaluating 348 patients who underwent biopsies before and after five years of therapy, 88% experienced an improvement in overall liver histology as measured by an improvement of at least two points in the Knodell score of HAI (histologic activity index) (Figure 4). Of the 94 patients who had cirrhosis at the start of therapy, 73% experienced regression of cirrhosis, and 72% had at least a two-point reduction in fibrosis scoring (Marcellin 2011).



**Figure 4. Changes in liver histology after five years of TDF treatment.** In a study looking at 348 patients with paired liver biopsies, regression of liver fibrosis and even liver cirrhosis (Ishak score 5 and 6) was found in the majority of patients.

## Criteria for treatment response

### Virologic response

- sustained decrease of HBV DNA, to at least  $<2,000$  IU/mL (corresponding to  $<10,000$  copies/mL), ideally to  $<60$  IU/mL ( $<300$  copies/mL).
- sustained HBe seroconversion in HBeAg positive patients
- ideally, loss of HBsAg

### Biochemical response

- sustained ALT normalization

### Histologic response

- reduction of fibrosis (histological staging)
- reduction of inflammatory activity (histological grading)

### Potential long-term effects

- avoidance of cirrhosis, hepatocellular carcinoma (HCC), transplantation, and death

## How to treat

Therapy of chronic hepatitis B is possible with PEG-IFN  $\alpha$  in order to induce an immunologic long-term control by finite treatment or with nucleos(t)ide analogs by long-term inhibition of HBV replication (Figure 5) (Table 2).

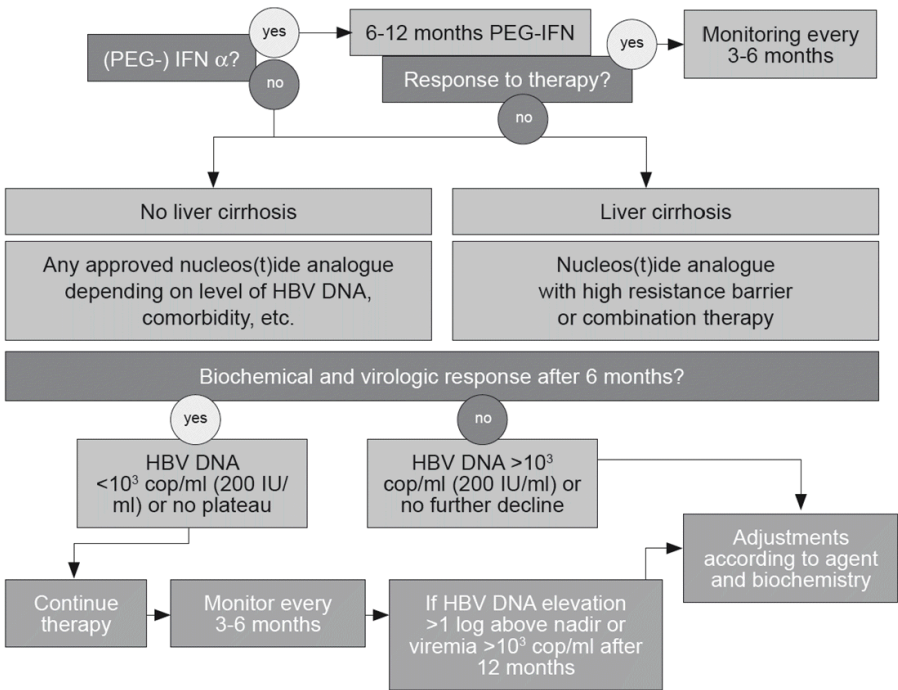
At first, the option of interferon therapy should be evaluated. However, if a patient does not fulfil the criteria for a higher likelihood for treatment success with PEG-IFN  $\alpha$ , has contraindications, or is intolerant, long-term therapy with nucleos(t)ide analogs is recommended (Figure 5). If a nucleos(t)ide analog is chosen, several parameters have to be considered prior to therapy: the antiviral efficacy of the drug, the durability of response, the resistance barrier, and the stage of liver disease.

If the initial viral load is low and liver cirrhosis has been excluded, any approved drug may be used. The use of LAM, however, should be restricted to patients with mild fibrosis and HBV DNA levels  $<10^5$  copies/ml. For patients with high-level HBV replication ( $>10^9$  copies/ml) only drugs with a high genetic barrier should be used (i.e., ETV or TDF) (Table 3).

## Treatment options

Because of a limited tolerability due to adverse events, duration with PEG-IFN  $\alpha$  is limited for a period of 6-12 months (maximum 24 months). Nucleoside and nucleotide analogs have a good tolerability and are used in long-term treatment. However, the efficacy of these oral agents can be hampered by emergence of resistance. Two interferons and five oral HBV polymerase inhibitors are currently approved for the treatment of chronic HBV infections: standard IFN  $\alpha$ -2b and PEG-IFN  $\alpha$ -2a, lamivudine (LAM), adefovir dipivoxil (ADV), telbivudine (LdT), entecavir (ETV) and tenofovir disoproxil fumarate (TDF) (Table 2). The efficacy of the available drugs after one year of treatment, assessed by the proportion of individuals with HBV DNA below the limit of detection, normalised transaminases and HBeAg seroconversion is shown in Figure 6.





**Figure 5. Treatment algorithm for chronic HBV infection according to the German Guidelines (Cornberg 2011).** The indication for interferon therapy should always be considered. For treatment with nucleoside or nucleotide analogs, agents with high genetic barrier against resistance such as entecavir or tenofovir should be preferred.

**Table 2. Overview of interferons and oral antiviral drugs currently approved for the treatment of HBV infection.**

Drug	Name	Dose	Duration
<b>Interferon α</b>			
Standard Interferon α-2a	Roferon®	2.5-5 mio. U/m <sup>2</sup> body surface 3x/week	4-6 months
Standard Interferon α-2b	Intron A®	5-10 mio. IU 3x/week	4-6 months
Pegylated Interferon α-2a	Pegasys®	180 µg/week	48 weeks
<b>Nucleoside analogs</b>			
Lamivudine	Zeffix®	100 mg/day	long-term*
Telbivudine	Sebivo®	600 mg/day	long-term*
Entecavir	Baraclude®	0.5 mg/day	long-term*
		1 mg/day for patients with lamivudine resistance	long-term*
<b>Nucleotide analogs</b>			
Adefovir dipivoxil	Hepsera®	10 mg/day	long-term*
Tenofovir disoproxil fumarate	Viread®	300 mg/day	long-term*

\* see Figure 6

**Table 3. Recommendations for the use of nucleos(t)ide analogs in clinical practice.**

<b>Drug</b>	<b>Advantage</b>	<b>Disadvantage</b>	<b>Recommendation</b>
Lamivudine (LAM)	<ul style="list-style-type: none"> <li>• Low treatment costs</li> <li>• Oral solution available for children or individual dosage in case of renal impairment</li> </ul>	<ul style="list-style-type: none"> <li>• High risk of resistance in long-term monotherapy</li> <li>• Cross-resistance to ETV and LdT</li> </ul>	<ul style="list-style-type: none"> <li>• Use as first-line therapy only in selected patients with low viral load</li> <li>• Prevention of exacerbation in HBsAg+, HBV DNA-patients with immunosuppression</li> <li>• Preemptive therapy in case of HBsAg-negative, anti-HBc positive patients with immunosuppression</li> <li>• Use in pregnancy possible</li> </ul>
Adefovir dipivoxil (ADV)	<ul style="list-style-type: none"> <li>• Experience in combination with LAM</li> <li>• No cross-resistance to LAM</li> </ul>	<ul style="list-style-type: none"> <li>• Moderate antiviral activity</li> <li>• Primary non-response in 10-20% of cases</li> <li>• Slow viral kinetics during therapy</li> <li>• Risk of viral resistance in long-term monotherapy</li> <li>• Nephrotoxicity</li> </ul>	<ul style="list-style-type: none"> <li>• Not to be used as first-line therapy</li> </ul>
Telbivudine (LdT)	<ul style="list-style-type: none"> <li>• High antiviral efficacy</li> <li>• Potentially no cross-resistance to entecavir</li> </ul>	<ul style="list-style-type: none"> <li>• Moderate risk for viral resistance in long-term monotherapy</li> <li>• Neuropathy and myopathy</li> </ul>	<ul style="list-style-type: none"> <li>• First-line therapy</li> <li>• Can be combined with TDF</li> </ul>
Entecavir (ETV)	<ul style="list-style-type: none"> <li>• High antiviral efficacy</li> <li>• Low risk for viral resistance in long-term monotherapy in lamivudine-naïve patients</li> <li>• Combination therapy with TDF as rescue therapy</li> <li>• Oral solution available for individual dosage in case of renal impairment</li> </ul>	<ul style="list-style-type: none"> <li>• In LAM-experienced patients high risk for the development of viral resistance and virologic failure in long-term monotherapy</li> </ul>	<ul style="list-style-type: none"> <li>• First-line therapy</li> <li>• Can be combined with TDF</li> </ul>
Tenofovir disoproxil fumarate (TDF)	<ul style="list-style-type: none"> <li>• High antiviral efficacy</li> <li>• Low risk for viral resistance in long-term monotherapy</li> </ul>	<ul style="list-style-type: none"> <li>• Nephrotoxicity</li> <li>• Decrease in bone mineral density</li> </ul>	<ul style="list-style-type: none"> <li>• First line therapy</li> <li>• Can be combined with ETV, LdT or LAM if needed</li> </ul>

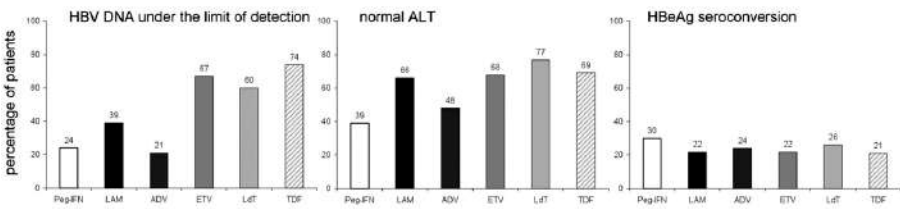
\* in HBV-monoinfected patients no renal toxicity was observed in 5 years of TDF treatment

## Interferons

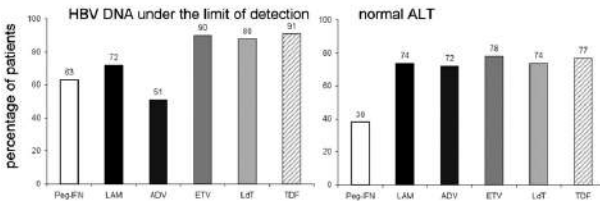
INF  $\alpha$  is a natural occurring cytokine with immunomodulatory, antiproliferative and antiviral activity. During treatment, the therapeutic efficacy of INF  $\alpha$  can often be clinically recognised by an increase of ALT levels to at least twice the baseline levels. These ALT flares often precede virologic response.

The main aim of INF  $\alpha$  treatment is to induce a long-term remission by finite treatment duration. Overall a long-term response defined by either HBeAg seroconversion or durable suppression of HBV DNA to low or undetectable levels can be achieved in approximately 30% of treated patients. In these responders the chance for HBsAg loss in the long-term is relatively high.

### a) HBeAg-positive patients



### b) HBeAg-negative patients



**Figure 6. One-year efficacy of medications currently approved for the treatment of chronic HBV infection (Lok 2009).** Treatment efficacy is expressed as suppression of HBV DNA below the limit of detection, ALT normalisation and rates of HBeAg seroconversion. As no head-to-head trials comparing the substances have been undertaken, differences in antiviral efficacy have to be interpreted with caution.

**Standard INF  $\alpha$ .** Standard INF  $\alpha$  was approved for treatment of chronic hepatitis B in 1992. INF  $\alpha$  is applied in dosages ranging from 5 million units (MU) to 10 MU every other day or thrice weekly. In a meta-analysis, a significant improvement in endpoints was shown in patients with HBeAg-positive chronic hepatitis B being treated with standard INF compared to untreated patients (Craxí 2003). Complete remission of fibrotic changes was observed in some patients and the loss of HBsAg occurred comparatively often. Furthermore, there was a trend towards reduction of hepatic decompensation (treated 8.9% vs. untreated 13.3%), hepatocellular carcinoma (1.9 vs. 3.2%), and liver associated deaths (4.9 vs. 8.7%) (Craxí 2003).

A significant decrease in ALT and in HBV DNA serum levels was also shown for standard INF  $\alpha$  in the treatment of HBeAg-negative chronic hepatitis B (Brunetto 2003). However, a high percentage (25-89%) of these patients relapses after the end of treatment showing elevation of ALT levels and a return of HBV DNA levels. The relapse rate seems to be higher when treatment duration is short (16 to 24 weeks)

compared to longer treatment (12 to 24 months). A retrospective comparison of IFN therapies lasting from 5 to 12 months showed that with longer treatment the chance of a long-term response was 1.6 times higher (normalization of ALT, HBV DNA  $<1 \times 10^6$  copies/ml 1-7 years after end of therapy). The overall response rates were 54% at the end of the therapy, 24% at 1 year after therapy, and 18% 7 years after therapy (Manesis 2001).

Patients with long-term response to treatment have a more favourable course than patients who were untreated, unresponsive, or who had a relapse interferon  $\alpha$  therapy with respect to progression to liver cirrhosis, liver associated deaths, and development of hepatocellular carcinoma (Brunetto 2003, Lampertico 2003). However, due to higher antiviral efficacy PEG-IFN  $\alpha$  should be preferred to standard IFN  $\alpha$ .

**PEG-IFN  $\alpha$ .** The addition of a polyethylene glycol molecule to the IFN resulted in a significant increase in half-life, thereby allowing administration once weekly. Two types of subcutaneously administered PEG-IFN  $\alpha$  were developed: PEG-IFN  $\alpha$ -2a and PEG-IFN  $\alpha$ -2b, of which PEG-IFN  $\alpha$ -2a was licensed for the treatment of chronic HBV infections in a weekly dose of 180  $\mu$ g for 48 weeks in both HBeAg-positive and HBeAg-negative patients. However, PEG-IFN  $\alpha$ -2b shows similar efficacy. After one year on treatment with PEG-IFN  $\alpha$ -2a and  $\alpha$ -2b, 22% to 27% of patients were reported to achieve HBeAg seroconversion (Janssen 2005, Lau 2005).

The safety profiles of standard IFN  $\alpha$  and PEG-IFN  $\alpha$  are similar. Following therapy termination a relatively high relapse rate is to be expected ( $>50\%$ ). The dose of 180  $\mu$ g per week applied for 48 weeks was recently shown to exert a stronger antiviral efficacy compared to administration for 24 weeks or to administration of 90  $\mu$ g per week (Liaw 2011). In a small Italian study it was shown that prolongation of 48 weeks of treatment with 180  $\mu$ g PEG-IFN  $\alpha$  per week by another 48 weeks of 135  $\mu$ g PEG-IFN  $\alpha$ -2a may enhance antiviral efficacy and increase the rate of patients achieving HBsAg loss, at least in HBeAg-negative patients with HBV genotype D (Lampertico 2010). However, the optimal treatment duration for PEG-IFN  $\alpha$  has not been defined yet and treatment beyond 48 weeks is not recommended by current guidelines.

**PEG-IFN  $\alpha$  in HBeAg-positive patients.** Four randomized, controlled studies investigating the efficacy of PEG-IFN  $\alpha$  in HBeAg-positive patients have been conducted (Crespo 1994, Chan 2005, Janssen 2005, Lau 2005). These studies compared 180  $\mu$ g PEG-IFN  $\alpha$  per week to standard IFN, LAM, and/or a combination treatment with PEG-IFN  $\alpha$  + LAM for 48 weeks. Sustained HBeAg seroconversion at the end of follow-up (week 72) was significantly higher in patients treated with PEG-IFN  $\alpha$ -2a alone or in combination with LAM than in patients treated with LAM alone (32% and 27% versus 19%) (Marcellin 2004).

Importantly, it was recently shown that PEG-IFN  $\alpha$  can induce immunomodulatory effects which persist beyond the end of therapy leading to high HBsAg clearance rates in the follow-up period. In a recent study, 97 patients with chronic HBV infection who had received treatment with standard IFN  $\alpha$  were retrospectively analyzed for a median period of 14 (range, 5-20) years. During the observation period, 28 patients (29%) of this cohort lost HBsAg (Moucari 2009).

**PEG-IFN  $\alpha$  in HBeAg-negative patients.** The efficacy and safety of 48 weeks treatment with 180  $\mu$ g PEG-IFN  $\alpha$ -2a once weekly + placebo, + 100 mg LAM daily, or LAM alone was compared in 177, 179, and 181 HBeAg-negative patients,

respectively. After 24 weeks of follow-up, the percentage of patients with normalisation of ALT levels or HBV DNA levels below 20,000 copies/ml was significantly higher with PEG-IFN  $\alpha$ -2a monotherapy (59% and 43%, respectively) and PEG-IFN  $\alpha$ -2a plus LAM (60% and 44%) than with LAM monotherapy (44% and 29%); the rates of sustained suppression of HBV DNA below 400 copies/ml were 19% with PEG-IFN  $\alpha$ -2a monotherapy, 20% with combination therapy, and 7% with LAM alone.

Also in HBeAg-negative patients HBsAg loss can be induced in some patients by PEG-IFN  $\alpha$  treatment. In a study in 315 patients who were treated with either PEG-IFN  $\alpha$ -2a, LAM 100 mg or a combination of both drugs for 48 weeks, three years after the end of treatment, the rate of HBsAg loss was 8.7% in those who had been treated with PEG-IFN  $\alpha$ -2a alone or in combination with LAM while no patient treated with LAM as monotherapy cleared HBsAg (Marcellin 2009a). Of the patients who had received a PEG-IFN  $\alpha$ -2a and who still had undetectable HBV DNA three years after treatment, 44% had lost HBsAg.

Prolongation of PEG-IFN  $\alpha$  treatment beyond 48 weeks may increase sustained response rates. This was found in an Italian study in 128 mainly genotype D-infected HBeAg-negative patients who were randomized to either treatment with 180  $\mu$ g/week PEG-IFN  $\alpha$ -2a for 48 weeks or a continuing treatment with PEG-IFN  $\alpha$ -2a at 135 $\mu$ g/week. Additionally, in a third arm patients received combination treatment with PEG-IFN  $\alpha$ -2a 180 $\mu$ g/week and LAM 100 mg/day, followed by 48 weeks of PEG-IFN  $\alpha$ -2a in the dosage of 135  $\mu$ g/week. As a result, 48 weeks after the end of treatment 26% of patients who had received 96 weeks of PEG-IFN treatment showed HBV DNA levels <2,000 IU/mL compared to only 12% of the patients who had received PEG-IFN for 48 weeks. Combination with LAM showed no additional effect (Lampertico 2010a).

## Nucleoside and nucleotide analogs

Nucleoside and nucleotide analogs inhibit HBV replication by competing with the natural substrate deoxyadenosine triphosphate (dATP) and causing terminating of the HBV DNA chain prolongation. They represent two different subclasses of reverse transcriptase inhibitors: while both are based on purines or pyrimidines, acyclic nucleotide analogs have an open (acyclic) ribose ring that confers greater binding capacity to resistant HBV polymerase strains.

Treatment duration for nucleos(t)ide analogs is not well-defined but a short-term application of these agents for 48 weeks is associated with prompt relapse in viremia and they should be administered for longer periods. Treatment efficacy of nucleoside and nucleotide analogs implies complete suppression of HBV DNA levels in serum. This should be achieved within six months if agents with high risk for resistance development as LAM, ADV, and LdT are used.

Effective long-term control of HBV replication with nucleoside or nucleotide analogs is associated with a reduction of long-term complications such as HCC and development of liver cirrhosis (Toy 2009). Studies with different nucleoside and nucleotide analogs have demonstrated that suppression of HBV replication is associated with a significant decrease in histologic inflammatory activity and fibrosis, including partial reversion of liver cirrhosis (Chen 2006, Iloeje 2006, Mommeja-Marin 2003, Chen 2010, Marcellin 2011, Schiff 2011). With increasing treatment duration HBeAg seroconversion rates increase (Liaw 2000, Lok 2000). Most

importantly, there is also evidence that effective inhibition of HBV replication can reduce HBV cccDNA, possibly running parallel to the decline in serum HBsAg levels (Werle-Lapostolle 2004, Wursthorn 2006). These findings may indicate that long-term antiviral therapy may lead to a complete response in a significant number of patients.

A central aspect of HBV polymerase inhibitor treatment is the prevention and management of HBV resistance to these drugs (see Chapter 10). Resistance against nucleoside or nucleotide analogs can occur during suboptimal treatment and often leads to aggravation of liver disease. Because of cross resistance between several nucleoside and nucleotide analogs, nucleoside-naïve and nucleoside-experienced patients have to be distinguished and prior nucleoside experience should be taken into account when choosing a second line therapy. However, highly potent substances such as ETV and TDF show minimal or even no resistance development in treatment-naïve patients over 5-6 years (Snow-Lampert 2011).

**Lamivudine (LAM).** LAM, a (-) enantiomer of 2' -3' dideoxy-3'-thiacytidine, is a nucleoside analog that was approved for the treatment of chronic HBV infection in 1988 with a daily dose of 100 mg. This dose was chosen based on a preliminary trial that randomly assigned 32 patients to receive 25, 100, or 300 mg of LAM daily for a total of 12 weeks (Dienstag 1995). In this study the dose of 100 mg was more effective than 25 mg and was similar to 300 mg in reducing HBV DNA levels. LAM exerts its therapeutic action in its phosphorylated form. By inhibiting both the RNA- and DNA-dependent DNA polymerase activities, the synthesis of both the first strand and the second strand of HBV DNA are interrupted.

Long-term LAM treatment is associated with an increasing rate of antiviral drug resistance reaching approximately 70% after 5 years in patients with HBeAg-positive HBV infections. Therefore, in many guidelines LAM is not considered a first-line agent in the treatment of chronic HBV infection any more. However, LAM still may play a role in combination regimens or in patients with mild chronic hepatitis B expressing low levels of HBV DNA ( $<10^5$  copies/ml). An early and complete virologic response to LAM within 6 months of therapy ( $<400$  copies/mL) constitutes a prerequisite for long-term control of HBV infection without the risk of developing resistance.

**Adefovir dipivoxil (ADV).** Adefovir dipivoxil was approved for treatment of chronic hepatitis B in the US in 2002 and in Europe in 2003. It is an oral diester prodrug of adefovir, an acyclic nucleotide adenosine analog that is active in its diphosphate form. Because the acyclic nucleotide already contains a phosphate-mimetic group, it needs only two, instead of three, phosphorylation steps to reach the active metabolite stage. ADV was the first substance with simultaneous activity against wild type, pre-core, and LAM-resistant HBV variants. It is active *in vitro* against a number of DNA viruses other than HBV and retroviruses (i.e., HIV). The dose of 10 mg per day was derived from a study comparing 10 mg versus 30 mg/d. The higher dosage leads to stronger suppression of HBV DNA levels but also to renal toxicity with an increase of creatinine levels (Hadziyannis 2003).

ADV was the first acyclic nucleotide that was widely used in the treatment of LAM-resistant HBV infections. However, the antiviral effect of ADV in the licensed dosage of 10 mg/day is rather low as compared to other available antivirals (Figure 4); this disadvantage makes ADV vulnerable to HBV resistance

(Hadziyannis 2006a). Now that TDF is approved, ADV should not be used as first-line monotherapy.

**Telbivudine (LdT).** Telbivudine is a thymidine analog which is active against HBV but at least *in vitro* not active against other viruses, including HIV and hepatitis C virus (HCV). LdT at 600 mg/day expresses higher antiviral activity compared to either LAM at 100 mg/day or ADV at 10 mg/day (Figure 4). More patients achieved HBeAg loss within 48 weeks as compared to other nucleos(t)ides.

LdT was reported to be non-mutagenic, non-carcinogenic, non-teratogenic, and to cause no mitochondrial toxicity. A favourable safety profile at a daily dose of 600 mg was demonstrated (Hou 2008, Lai 2007). However, CK elevations were observed more often as compared to the group treated with LAM and neurotoxicity may be an issue when LdT is administered in combination with PEG-INF  $\alpha$  (Fleischer 2009). Thus, in the GLOBE trial, during a period of 104 weeks grades 3/4 elevations in CK levels were observed in 88 of 680 (12.9%) patients who received LdT and in 28 of 687 (4.1%) patients who received LAM ( $p < 0.001$ ) (Liaw 2009). However, rhabdomyolysis was not observed. Peripheral neuropathy was described in 9 of 48 (18.75%) patients who received combination therapy of PEG-INF and LdT and only in 10 of 3500 (0.28%) patients who received LdT monotherapy (Goncalves 2009).

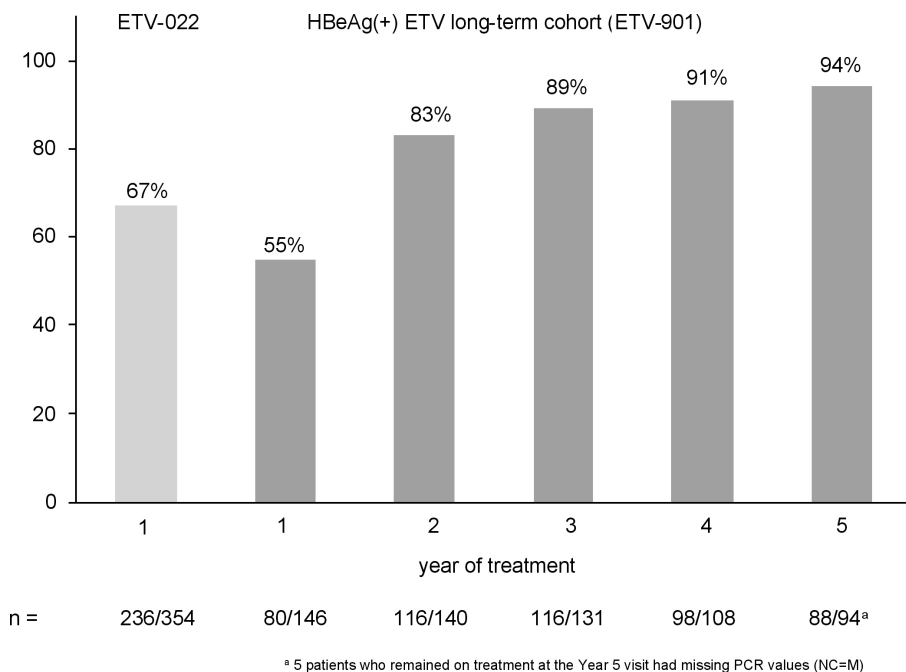
Resistance to LdT has been found to occur in up to 21% after 2 years of treatment (Tenney 2009), predominantly in patients who did not achieve undetectable HBV DNA level after 24 weeks of treatment (Zeuzem 2009). LdT shows cross-resistance to LAM and ETV. As a consequence LdT should not be used in LAM or ETV refractory patients.

**Entecavir (ETV).** Entecavir, a cyclopentyl guanosine nucleoside analog, is a selective inhibitor of HBV replication and was licensed in 2006. Entecavir blocks all three polymerase steps involved in the replication process of the hepatitis B virus: first, base priming; second, reverse transcription of the negative strand from the pregenomic messenger RNA; third, synthesis of the positive strand of HBV DNA. In comparison to all other nucleoside and nucleotide analogs, ETV is more efficiently phosphorylated to its active triphosphate compound by cellular kinases. It is a potent inhibitor of wild-type HBV but is less effective against LAM-resistant HBV mutants. Therefore, ETV was approved at a dose of 0.5 mg per day for treating naïve HBeAg-positive and -negative patients at the dose of 1 mg per day for patients with prior treatment with LAM (Lai 2005, Sherman 2008). ETV and LAM are the only nucleoside analogs available as a tablet and an oral solution.

Treatment-naïve HBeAg-positive patients achieved undetectable HBV DNA levels in 67% and 74% after one and two years of ETV treatment, reaching 94% after five years, respectively (Figure 4, Figure 7) (Chang 2010). Long-term studies in ETV responder patients demonstrated that response can be maintained in nearly all patients over an observation period of up to six years. So far, the rate of resistance at six years of treatment is estimated to be approximately 1.2% for treatment-naïve patients (Tenney 2009). Loss of HBsAg occurs in 5% of treatment-naïve individuals after two years of ETV therapy (Gish 2010). A non-randomised Italian study in a mixed population of predominantly HBeAg-negative patients could demonstrate undetectable HBV DNA levels in 91% and 97% of patients at 1 and 2 years of ETV treatment, respectively (Lampertico 2010).

In LAM-resistant patients ETV is less potent. Only 19% and 40% of these patients achieved undetectable HBV DNA after one and two years, respectively, despite an increased dose of 1 mg/day (Gish 2007, Sherman 2008). Due to cross-resistance up to 45% of patients with LAM resistance develop resistance against ETV after 5 years of treatment (Tenney 2009).

ETV has a favourable tolerability profile and can be easily adjusted to renal function. However, ETV may cause severe lactic acidosis in patients with impaired liver function and a MELD score of >20 points (Lange 2009).

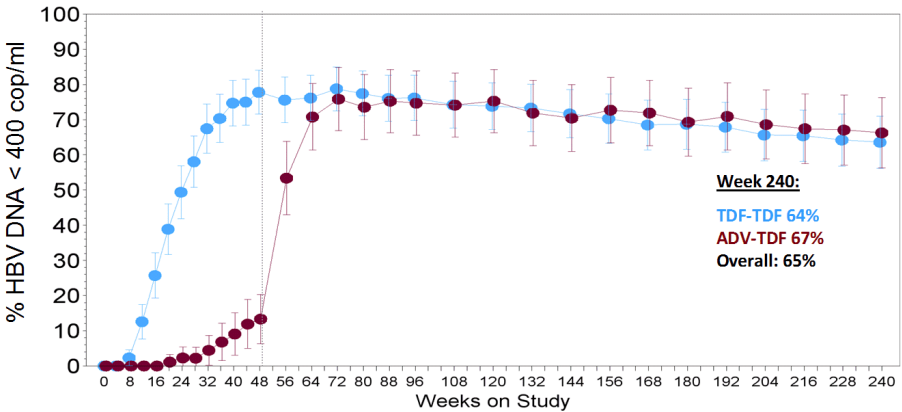


**Figure 7. Percentage of patients achieving HBV DNA levels <400 copies/ml during long-term treatment with 1 mg ETV per day (Chang 2010).** The long-term cohort ETV-901 consists of HBeAg-positive patients initially treated in the study ETV-022 (ETV 0.5 mg/day), which was designed for a duration of one year.

**Tenofovir (TDF).** Tenofovir disoproxil fumarate, an ester prodrug form of tenofovir (PMPA; (R)-9-(2-phosphonylmethoxypropyl)), is an acyclic nucleoside phosphonate, or nucleotide analog closely related to ADV. TDF has selective activity against retroviruses and hepadnaviruses and is currently approved for the treatment of HIV infection and of chronic hepatitis B. TDF showed marked antiviral efficacy over five years with complete virologic response rates (HBV DNA <400 copies/ml) reaching nearly 100% in treatment-naïve HBeAg-negative and -positive patients (Figure 8). In HBeAg-positive patients, 11% of patients experienced HBsAg loss (Marcellin 2011). Other clinical studies showing a high efficacy of TDF in LAM-resistant HBV infections irrespective of the mutation mediating LAM resistance (van Bömmel 2010, Levrero 2010). Due to possibly existing cross-



resistance to ADV, the efficacy of TDF might be hampered by the presence of ADV resistance in patients with high HBV viremia; however, a breakthrough of HBV DNA during TDF treatment in patients with previous ADV failure or in treatment-naïve patients has not been observed (van Bömmel 2010, Levrero 2010, Snow-Lampert 2011).



**Figure 8. Percentage of patients achieving HBV DNA levels <400 copies/mL during long-term treatment with 300 mg TDF per day (Marcellin 2010).** Patients were originally randomised to treatment with 300 mg TDF or 10 mg ADV per day. After one year, patients receiving ADV were switched to TDF. Please note that the on-treatment analysis excluding the missing patients showed undetectable HBV DNA in 96% of the TDF-TDF group and in 100% of the ADV-TDF group.

TDF is generally well-tolerated and not associated with severe side effects. For HBV-monoinfected, treatment-naïve patients, renal safety during TDF monotherapy was investigated in three studies. In a randomized study comprising HBeAg-negative patients, none of 212 patients treated with TDF for three years and none of 112 patients who were treated with ADV for one year and then switched to TDF for two years had a decrease in GFR to levels of <50 ml/min or an increase of serum creatinine levels to >0.5 mg/dl (Marcellin 2009). In a similar study in HBeAg-positive patients, of 130 patients treated with TDF for 3 years and of 76 patients treated with ADV for one year and consecutively with TDF for 2 years, only one patient showed an increase in serum creatinine levels >0.5 mg/dl starting at year two (Heathcote 2011). In a sub-analysis of both studies in 152 HBeAg-positive and -negative Asian patients, no increase of serum creatinine >0.5 mg/dl or of eGFR <50 ml/min was found in up to 3 years of TDF treatment (Liaw 2009a). In contrast, in a recent study a benefit in renal function could be found in treated patients when compared to untreated patients with HBV infection, which might reflect a lower incidence of glomerulonephritis caused by HBsAg-induced immune complexes in treated patients (Mauss 2011).

The use of tenofovir in HIV-coinfected patients is discussed in detail in Chapter 17.

**Combination therapy as first-line treatment.** As of now, first-line combination treatments with nucleoside and nucleotide analogs or PEG-IFN  $\alpha$  + nucleos(t)ide analogs are not indicated. There is only one study comparing a combination therapy

with LAM and ADV to LAM monotherapy in untreated patients (Sung 2008). In this study, there was no difference in the virologic and biochemical response between both groups. The rate of LAM resistance was much lower in the combination group. However, the development of resistance could not be completely avoided even with the use of an additional dose of ADV. Another study analyzing the combination of LAM with LdT also showed no benefit for combination therapy (Lai 2005).

Especially in patients with liver cirrhosis, a fast and complete suppression of HBV replication is desirable. A monotherapy with ETV was found to be as safe and effective as monotherapy with TDF, and an addition of emtricitabine to TDF showed no improvement in response. Therefore, in these patients as well, combination treatment is currently not recommended (Liaw 2011).

Combination treatment with LdT and PEG-IFN  $\alpha$  should not happen. In a recent study, peripheral neuropathy was described in 9 of 48 (18.8%) patients who received combination therapy of PEG-IFN  $\alpha$  and LdT and only in 10 of 3,500 (0.28%) patients who received LdT monotherapy (Goncalves 2009). Although combination of LAM plus PEG-IFN  $\alpha$  failed to demonstrate benefit when evaluated at the end of follow-up in most studies, a more pronounced on-treatment virologic response (week 48) was observed with combination therapy as compared to LAM or PEG-IFN  $\alpha$  alone. This more profound HBV DNA suppression induced by the combination regimen was associated with a lower incidence of LAM resistance (presence of resistance mutations in 1% vs. 18% at the end of therapy).

However, combination therapies between PEG-IFN  $\alpha$  and more potent nucleos(t)ide analogs may be attractive. Recently, a combination treatment of ETV and PEG-IFN  $\alpha$  after 4 years of complete response to ETV was superior to continuation of ETV treatment by HBeAg and HBsAg loss and seroconversion rates (Ning 2011). Similar studies are currently being undertaken investigating combination treatment of PEG-IFN  $\alpha$  and TDF. However due to the preliminary character of the results a combination treatment of nucleos(t)ide analogs plus PEG-IFN  $\alpha$  is still not recommended.

## Choosing the right treatment option

One can choose either to treat with PEG-IFN  $\alpha$  in order to induce a long-term control by finite treatment or with nucleos(t)ide analogs to inhibit HBV replication in the long-term (Figure 5).

At first, interferon therapy should be evaluated. However, if a patient does not fulfil the criteria for PEG-IFN  $\alpha$ , has contraindications, or is intolerant, long-term therapy with nucleos(t)ide analogs is recommended. If a nucleos(t)ide analog is chosen several parameters have to be considered prior to therapy: the antiviral efficacy of the drug, the durability of response, the resistance barrier, and the stage of liver disease.

If the initial viral load is low and liver cirrhosis has been excluded, any approved drug may be used. The use of LAM, however, should be restricted to patients with mild fibrosis and HBV DNA levels  $<2,000$  IU/mL (or  $<10^5$  copies/mL). For patients with high-level HBV replication ( $>2 \times 10^8$  IU/mL or  $>10^9$  copies/mL) only drugs with a high genetic barrier should be used (i.e., ETV or TDF) (Table 3).

## Prognostic factors for treatment response

Several factors are positively associated with long-term remission and may help to guide treatment decisions. Pretreatment factors predictive of HBeAg seroconversion are low viral load, high ALT levels (above 2-5 x ULN) and high histological grading (Flink 2006, Hadziyannis 2006a, Lai 2007, Perrillo 1990, Perrillo 2002, Wong 1993, Yuen 2007, Zoulim 2008). These general baseline predictors are relevant especially for treatment regimens with PEG-IFN  $\alpha$  but may in part be relevant also for nucleos(t)ide analogs (Table 4).

A pooled analysis from the two largest trials using PEG-IFN  $\alpha$ -2a or -2b in chronic hepatitis B tried to calculate a score predicting successful interferon therapy based on an individual patient's characteristics (viral load, ALT level, HBV genotype, age, gender). However, this approach may only be feasible in HBeAg-positive patients (Buster 2009).

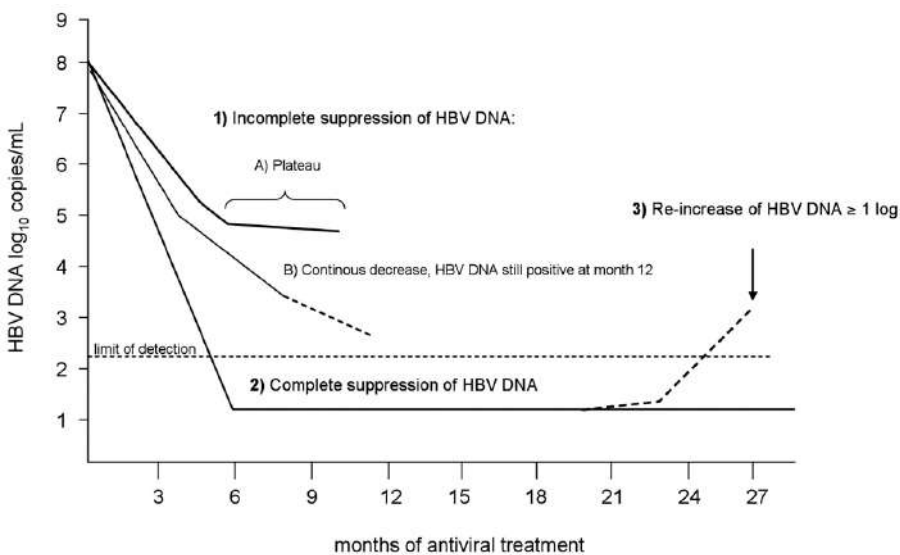
**Table 4. Predictors of response to antiviral therapy.**

	Nucleos(t)ide analogs	Peg-interferon $\alpha$
<b>Before treatment</b>	Low viral load (HBV DNA $\leq 10^7$ IU/mL), high serum ALT levels (above 3 times ULN), high activity scores on liver biopsy (at least A2)	
<b>During treatment</b>	Undetectable HBV DNA in a real-time PCR assay at 24 or 48 weeks is associated with HBeAg seroconversion in HBeAg-positive patients and lower incidence of resistance	HBV DNA decrease $< 20,000$ IU/ml at 12 weeks is associated with 50% chance of HBeAg seroconversion in HBeAg-positive patients and with a 50% chance of sustained response in HBeAg-negative patients
<b>HBeAg decrease</b>		HBeAg decrease at week 24 may predict HBeAg seroconversion
<b>HBV genotype</b>	HBV genotype shows no influence on suppression of HBV DNA levels. HBsAg seroconversions only observed for genotypes A and D	Association with HBV genotype A and B and response to IFN $\alpha$ is higher than with genotypes C and D, however the association is weak and HBV genotype should not be the only argument for treatment decision

**HBV genotypes and treatment response.** HBV genotypes have been shown to be associated with IFN  $\alpha$  treatment success. Patients with HBV genotype A, prevalent in northern Europe and the US, show a much higher rate of HBeAg and HBsAg seroconversion than patients with HBV genotype D, prevalent in the south of Europe, or the HBV genotypes B or C originating from Asia (Keeffe 2007, Wiegand 2008). During treatment with nucleos(t)ide analogs, suppression of HBV replication and induction of HBeAg loss can be achieved regardless of the present genotype. However, HBsAg loss was almost exclusively observed in patients with genotypes A or D.

**HBV DNA levels and treatment response.** During antiviral therapy, the decrease of HBV DNA levels from baseline is the most important tool in monitoring treatment efficacy. Complete response to antiviral therapy is defined as suppression of HBV DNA to below the limit of detection as measured by a sensitive real time PCR assay (Figure 9). Incomplete suppression is characterized by persistent HBV

replication despite antiviral therapy. Ongoing HBV replication should be avoided to prevent the selection of resistant HBV strains by replication of the virus in the presence of drug in the so-called “plateau phases”. An HBV DNA breakthrough despite continuous antiviral therapy is often caused by viral resistance. Measuring of HBV DNA kinetics early during therapy will help to guide antiviral treatment and to establish early stopping rules or add-on strategies to avoid antiviral failure (Figure 9).



**Figure 9. Possible courses of HBV DNA levels during treatment with nucleoside or nucleotide analogs.** Incomplete suppression of HBV DNA results in either a “plateau phase” or in a continuous slow decline. A plateau phase represents a high risk for selection of resistant HBV variants, therefore treatment should be changed to a more effective agent or combination therapy. A continuous slow decline should induce a treatment change after 6 months if drugs with a low genetic barrier like LAM or LdT are used. If drugs with a high genetic barrier like ETV or TDF are applied, a continuous slow decline can be monitored for at least 12 months without increased risk of consecutive HBV resistance.

Incomplete or partial virologic response to oral nucleoside or nucleotide analogs is defined as a decrease of HBV DNA  $>1 \log_{10}$  but remaining measurable (Lavanchy 2004) (Figure 9). The definition of partial response depends on the type of treatment; thus, for agents with a high genetic barrier against resistance like ETV or TDF partial response is defined after 12 months and for substances with a low genetic barrier like LAM or LdT, after 6 months of monotherapy. In case of partial response to a drug with a low genetic barrier, an appropriate rescue therapy should be initiated. By current guidelines, a combination treatment with a nucleotide analog is recommended for these patients. However, it was recently shown that patients with partial response to LAM or to ADV have a high probability of responding to TDF monotherapy, without risking the development of resistance (Heathcote 2011, Marcellin 2011b, van Bömmel 2010, Berg 2010). Patients with a partial response to ADV were also shown to have a high probability of responding to a subsequent

monotherapy with ETV, irrespective of the presence of mutations associated with HBV resistance to ADV (Leung 2009, Leung 2009a).

For patients with partial response to a drug with a high genetic barrier as ETV or TDF, current guidelines also recommend the initiation of a combination treatment. Recently published long-term studies have shown that the continuation of a new monotherapy in these patients does increase the percentage of patients with undetectable HBV DNA without increasing the risk of development of resistance (Chang 2010, Marcellin 2011b, Snow-Lampert 2011) (Figure 7, Figure 8). Thus, during monotherapy with TDF in HBeAg-positive and HBeAg-negative patients, an increase of patients with complete suppression of HBV DNA between the end of the first and the end of the fifth year of treatment from 81% and 90% to 100% was shown.

For monotherapy with ETV at 1 mg/day, an increase from 55% to 91% and 94% after the fourth and fifth years was demonstrated (Chang 2010). In case of incomplete viral suppression at week 48, a continuation of monotherapy with TDF or ETV 1 mg is advisable as long as HBV DNA levels decrease continuously. However, the debate on whether switching or adding a second drug as optimal management is still unanswered.

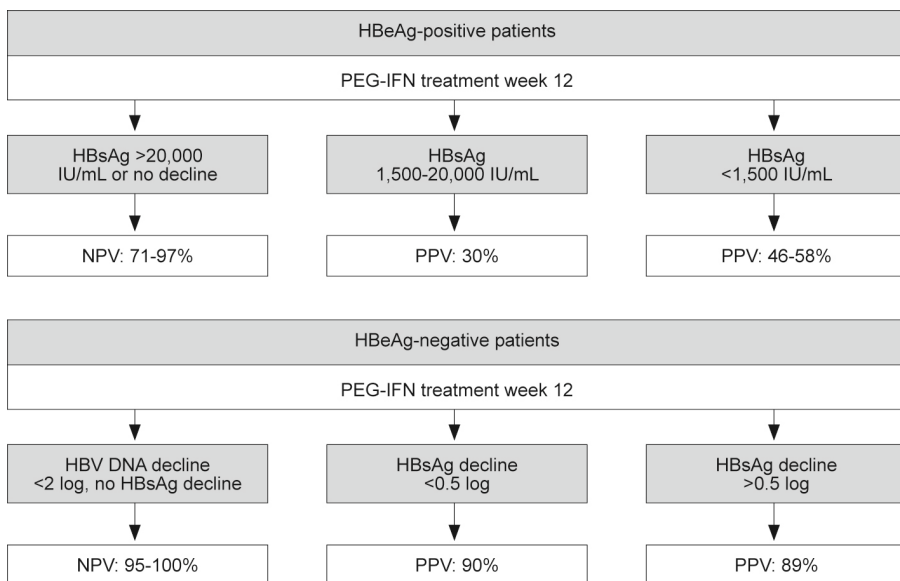
Even though prolongation of monotherapy with ETV or TDF will probably lead to undetectable HBV DNA in the long term in most patients, a fast suppression of HBV replication is mandatory in some patients (e.g., those with liver cirrhosis) to stop the progression of liver disease. For these patients, no definite therapeutic strategies have been evaluated yet. Preliminary results of a study assessing the efficacy of a rescue combination therapy with ETV and TDF have recently been able to induce suppression to undetectable levels in most patients with partial response; however, data on long-term efficacy and safety are not available (Petersen 2011).

In any case of treatment failure, adherence to therapy should be evaluated prior to treatment modification. Elimination of HBV DNA during TDF-based therapeutic regimes can drop from 87% to 71% of cases if adherence is not ensured, which is also important in preventing drug resistance (Berg 2010).

Since only 30-35% of all patients treated with PEG-IFN  $\alpha$  reach HBeAg seroconversion after 48 weeks, studies have been conducted recently to predict the probability of seroconversion in relation to viral kinetics. In one retrospective analysis early prediction of stable seroconversion was possible by week 12 of therapy if HBV DNA had reached levels below 5 log<sub>10</sub> IU/mL within this short treatment period (Fried 2005). In 53% of these patients, HBeAg seroconversion was observed while patients with HBV DNA levels of 5 to 9 log<sub>10</sub> copies/ml or levels above 9 log<sub>10</sub> IU/mL achieved HBeAg seroconversion in only 17% and 14%, respectively.

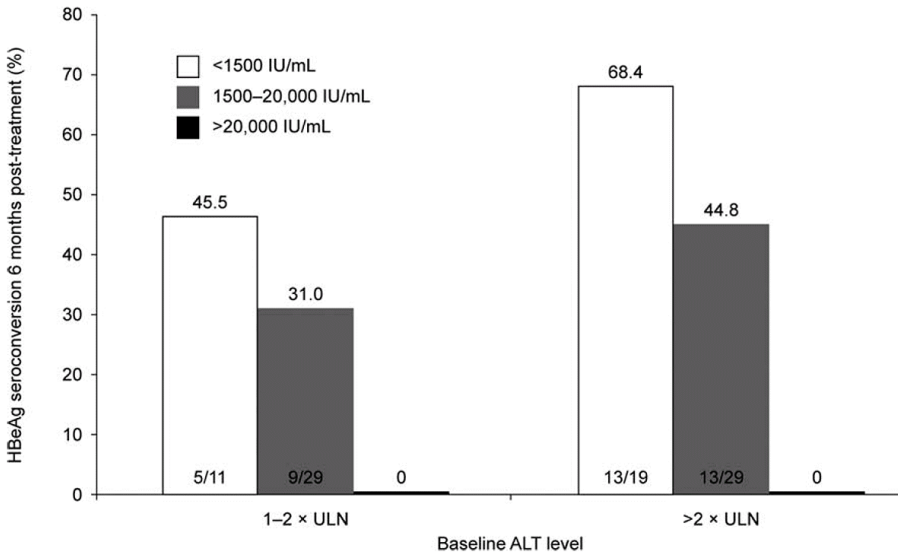
**Timepoint of HBeAg loss.** In one study with 172 patients who were treated with PEG-IFN  $\alpha$ -2b as monotherapy or in combination with LAM, the loss of HBeAg within the first 32 weeks of treatment was shown to be an on-treatment predictor for HBsAg loss during a mean period of 3.5 years after the end of treatment. HBsAg loss was found in 36% of the patients with early HBeAg loss and only in 4% of the patients with HBeAg loss after 32 weeks of treatment (Buster 2009).

**HBsAg levels and treatment response.** Response of HBeAg-positive and HBeAg-negative patients to PEG-IFN treatment can be predicted by measuring HBsAg levels before and changes of HBsAg levels during treatment (Figure 10).



**Figure 10. On-treatment prediction of treatment response by HBsAg levels.** In different trials, an association of the decline in HBsAg levels within the first 12 weeks of PEG-IFN  $\alpha$  treatment and treatment response defined as HBV DNA levels <2,000 copies/mL six months after treatment was found (Zonneveld 2010, Piratvis-uth 2011, Lau 2009, Gane 2011, Rijckborst 2010, Moucari 2009). Patients showing no decline in HBsAg levels at week 12 had only a very small chance of long-term response.

During PEG-IFN treatment for HBeAg-positive chronic HBV infection, an absence of a decline in HBsAg levels at week 12 of treatment reduces the probability of response to <5% in one study (Sonnefeld 2010). In the NEPTUNE trial investigating the predictive value of HBsAg levels in 114 HBeAg-positive patients receiving PEG-IFN  $\alpha$ 2a over 48 weeks, it was shown that in patients achieving suppression of HBsAg to levels <1,500 IU/mL after 12 weeks of treatment, the chance of reaching HBeAg seroconversion, suppression of HBV DNA to levels <2000 IU/mL and HBsAg loss 6 months after treatment was 58%, 52% and 10%, compared to 42%, 31% and 0% in patients with HBsAg levels between 1500-20,000. In this study, patients still showing HBsAg levels >20,000 IU/mL after 12 weeks of treatment achieved none of the endpoints (Gane 2011). Beyond that, the probability of HBeAg loss rose to 68% in patients with elevation of ALT levels >2 x the upper limit of normal at treatment initiation (Figure 11).



**Figure 11. The level of HBsAg levels after 12 weeks of treatment with PEG-IFN  $\alpha$ -2a is predictive for HBeAg seroconversion six months after treatment.** A combination of ALT levels and HBsAg decline improves positive predictive value in these patients (Gane 2011).

Also in HBeAg-negative patients the decrease of HBsAg after 12 weeks of PEG-IFN  $\alpha$  treatment can predict long-term response. This prediction can be made even more precise regarding the kinetics of both HBsAg and HBV DNA. In another study comprising 48 patients who were treated with PEG-IFN  $\alpha$ -2a, a decrease in serum HBsAg levels of 0.5 and 1  $\log_{10}$  IU/mL at weeks 12 and 24 of therapy was associated with a positive predictive value for HBsAg loss of 90% and 97% at week 96 after treatment, respectively (Moucarri 2009).

## Monitoring before and during antiviral therapy

Before therapy, HBV DNA levels should be measured with a highly sensitive assay. These results should be confirmed 1-2 months after initiation of therapy. In addition, ALT levels reflecting the inflammatory activity as well as creatinine levels should be determined. HBV genotyping is only recommended in patients who are considered candidates for treatment with interferon. HBV resistance testing can be useful in patients with prior failure to more than one nucleoside/nucleotide analog, but this is not yet a standard diagnostic approach. HBV resistance has to be expected when an increase of HBV DNA of  $>1 \log_{10}$  during antiviral treatment is observed. In cases of primary treatment failure an appropriate second line treatment can be chosen without resistance testing.

During therapy, HBV DNA, ALT and creatinine levels should be measured initially, after 4 to 6 weeks and then every 3 months. The early identification of viral resistance and an early adjustment of therapy are crucial. Patients with suppression of HBV replication to  $<300$  copies/ml (60 IU/ml) for at least 2 years may perhaps

be scheduled at 6 month intervals (Table 5). However, no studies have been performed that support this procedure.

In HBeAg-positive patients, HBeAg and anti-HBe as well as HBsAg and anti-HBs should be also measured if HBV DNA levels become undetectable to identify seroconversion as an endpoint of HBV therapy (Table 5).

Because the risk for HCC development remains increased even in patients with complete suppression during long-term treatment with nucleos(t)ide analogs, these patients should still regularly receive ultrasound examinations (Figure 12) (Papatheodoridis 2011).

**Table 5. Recommendation for laboratory tests for monitoring antiviral therapy.**

Tests before antiviral treatment	Interval
HBV DNA quantitative	
HBeAg, anti-HBe	
HBsAg quantitative	If IFN-based treatment is planned
HBV genotype	If IFN-based treatment is planned
ALT level	
Creatinine level	
Other chemistry tests	
Tests during antiviral treatment	Interval
HBV DNA quantitative	After 4-6 weeks, after 12 weeks, then every 3-6 months
HBeAg, anti-HBe	3-6 months, if HBV DNA is undetectable
HBsAg, anti-HBs	3-6 months, in HBeAg-positive patients after HBeAg seroconversion in and HBeAg-negative patients if DNA is undetectable
HBV	
HBV resistance test	If HBV DNA increases >1 log during antiviral treatment and pretreatment history is not tractable, but first check for treatment adherence!
ALT level	Initially every month, than every 3-6 months
Creatinine level*	Every 3-6 months
Other chemistry tests	Every 3-6 months

\* Patients treated with TDF should initially be monitored every 4 weeks to watch for decrease of kidney function

## Treatment duration and stopping rules

In HBeAg-positive patients continuous treatment with nucleos(t)ide analogs is necessary as long as HBeAg seroconversion is not achieved. Even after seroconversion antiviral therapy should be continued for at least another 12 months to avoid the risk of “seroreversion” upon stopping the nucleos(t)ide analog therapy.

Criteria for optimal treatment duration with nucleos(t)ide analogs are still lacking in patients with HBeAg-negative chronic hepatitis B, therefore currently unlimited treatment with nucleos(t)ide analogs is recommended.

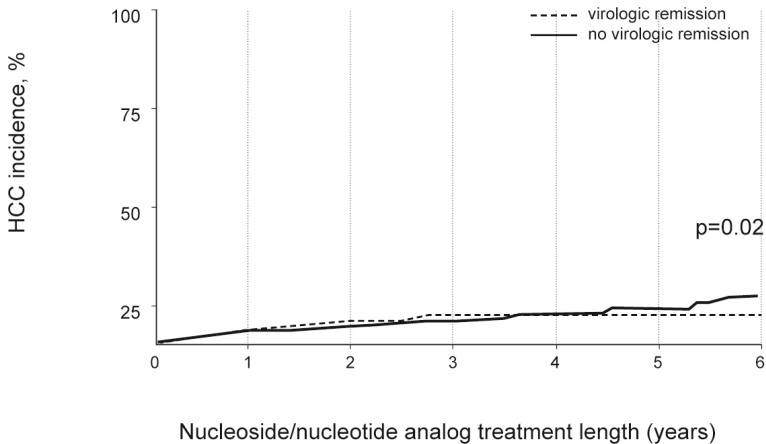
PEG-IFN  $\alpha$  should be administered for 48 weeks in HBeAg-positive and -negative patients.

Recently, the effect of stopping therapy after a long-term ADV treatment of 4 to 5 years with complete viral suppression was recently evaluated (Hadziyannis 2008). Despite the fact that all patients suffered a slight virologic relapse within 3 months of stopping therapy, most patients went below detection over the following 4 years



without any therapy. Moreover, 28% of the patients lost HBsAg. But final recommendations about the treatment period with defined stopping rules do not exist for HBeAg negative patients.

In patients with liver cirrhosis oral antiviral treatment should not be discontinued at any time point because of the risk of liver decompensation during a virologic rebound.



#### Patients at risk

No remission	578	570	509	449	336	278	196
In remission	228	221	159	113	85	59	39

**Figure 12. Cumulative incidence of hepatocellular carcinoma (HCC) in 818 patients with HBeAg-negative chronic hepatitis B (CHB) treated with nucleos(t)ide analogs.** Virological remission defined as durable suppression of HBV DNA to levels <200 IU/mL did not significantly affect the HCC incidence in the long term ( $p=0.38$ ) (Papatheodoridis 2011).

## Treatment of HBV infection in special populations

**Pregnancy.** For a neonate born to a mother with high levels of HBV DNA (>8 log<sub>10</sub> copies/mL) the risk of perinatal transmission is elevated. Therefore, antiviral treatment is principally recommended in these women. PEG-IFN  $\alpha$  is not indicated in pregnant women, but most nucleos(t)ide analogs can be used. The risk of teratogenicity of nucleos(t)ide analogs is assessed by a classification based on data gathered in clinical trials as well as through the FDA Pregnancy Registry. TDF and LdT are listed as pregnancy category B drugs and LAM, whereas ADV and ETV as category C drugs.

In pregnant women with high levels of HBV DNA, LAM treatment during the last trimester of pregnancy was reported to reduce the risk of intrauterine and perinatal transmission of HBV if given in addition to passive and active vaccination by HBIG and HBV (van Zonneveld 2003). During treatment with TDF, the birth defect prevalence was recently shown to be as high as during treatment with LAM (Brown 2009). Finally, LdT administered for an average of 15 weeks at the end of pregnancy plus active-passive immunization to neonates reduced vertical transmission rates from 23% to 4% over immunization alone (Han 2011). However,

treatment with nucleos(t)ide analogs during pregnancy should be carefully monitored and limited to the second and third trimester. As exacerbations of chronic hepatitis B may occur, women with HBV should be monitored closely after delivery (ter Borg 2008).

**Immunosuppression.** During immunosuppressive treatment, a reactivation of an asymptomatic or inactive HBV infection can occur in 20% to 50% of patients (Lok 2009). Reactivations can occur in HBsAg carriers, but also in HBsAg-negative but anti-hepatitis B core antibody (HBc)-positive patients. These reactivations are characterised by increase in HBV replication followed by increase in liver inflammation during immune reconstitution resulting in liver damage or even liver failure in some patients (Feld 2010, Roche 2011).

HBV reactivation was especially frequently observed during treatment with corticosteroids and antitumor necrosis factor therapies (i.e., infliximab, etanercept, adalimumab), anti-CD20 therapies (i.e., rituximab-containing chemotherapeutics), intra-arterial chemoembolisation for HCC (Vassilopoulos 2007, Moses 2006, Park 2005, Rutgeerts 2009). Reactivations during chemotherapy tend to appear predominantly in men as well as in those undergoing treatments for breast cancer or lymphoma.

Prior to initiating immunosuppressive therapies, screening for HBV infection is recommended (Lok 2009, EASL 2009). Patients with baseline HBV DNA levels <2,000 IU/mL should continue antiviral therapy for 6-12 months after the discontinuation of chemotherapy/immunosuppression, while patients with baseline HBV DNA levels >2,000 IU/mL should continue HBV therapy until they reach a treatment endpoint.

## References

- Akarca US. Chronic hepatitis B. A guideline to diagnosis, approach, management, and follow-up 2007. Turkish Association for the Study of Liver. Turk J Gastroenterol 2008;19:207-30. ([Abstract](#))
- Beasley RP. Hepatitis B virus. The major etiology of hepatocellular carcinoma. Cancer 1988;61:1942-56. ([Abstract](#))
- Berg T, Marcellin P, Zoulim F, et al. Tenofovir is effective alone or with emtricitabine in adefovir-treated patients with chronic-hepatitis B virus infection. Gastroenterology 2010;139:1207-17. ([Abstract](#))
- Brown R, Goodwin D, Peschell K, et al. Tenofovir Disoproxil Fumarate-Containing Regimens in Pregnancy: Report From the Antiretroviral Pregnancy Registry. 60th Annual Meeting of the American Association for the Study of Liver Diseases, October 30 - November 3, 2009 Boston, USA. Abstract 407.
- Brunetto MR, Oliveri F, Colombatto P, et al. Treatment of HBeAg-negative chronic hepatitis B with interferon or pegylated interferon. J Hepatol 2003;39:S164-7. ([Abstract](#))
- Brunetto MR, Oliveri F, Colombatto P, et al. Hepatitis B surface antigen serum levels help to distinguish active from inactive hepatitis B virus genotype D carriers. Gastroenterology 2010;139:483-90. ([Abstract](#))
- Buster EH, Flink HJ, Simsek H, et al. Early HBeAg loss during peginterferon alpha-2b therapy predicts HBsAg loss: results of a long-term follow-up study in chronic hepatitis B patients. Am J Gastroenterol 2009;104:2449-57. ([Abstract](#))
- Buster EH, van Erpecum KJ, Schalm SW, et al. Treatment of chronic hepatitis B virus infection - Dutch national guidelines. Neth J Med 2008;66:292-306. ([Abstract](#))
- Carosi G, Rizzetto M. Treatment of chronic hepatitis B: recommendations from an Italian workshop. Dig Liver Dis 2008;40:603-17. ([Abstract](#))
- Chan HL, Leung NW, Hui AY, et al. A randomized, controlled trial of combination therapy for chronic hepatitis B: comparing pegylated interferon-alpha2b and lamivudine with lamivudine alone. Ann Intern Med 2005;142:240-50. ([Abstract](#))

- Chang TT, Lai CL, Kew Yoon S, et al. Entecavir treatment for up to 5 years in patients with hepatitis B e antigen-positive chronic hepatitis B. *Hepatology* 2010;51:422-30. (Abstract)
- Chang TT, Liaw YF, Wu SS, et al. Long-term entecavir therapy results in the reversal of fibrosis/cirrhosis and continued histological improvement in patients with chronic hepatitis B. *Hepatology* 2010;52:886-93. (Abstract)
- Chen CJ, Yang HI, Su J, et al. Risk of hepatocellular carcinoma across a biological gradient of serum hepatitis B virus DNA level. *JAMA* 2006;295:65-73. (Abstract)
- Chen YC, Chu CM, Liaw YF. Age-specific prognosis following spontaneous hepatitis B e antigen seroconversion in chronic hepatitis B. *Hepatology* 2010;51:435-44. (Abstract)
- Cho SW, Koh KH, Cheong JY, et al. Low efficacy of entecavir therapy in adefovir-refractory hepatitis B patients with prior lamivudine resistance. *J Viral Hepat* 2009 Aug 12. *J Viral Hepat* 2010;17:171-7. (Abstract)
- Coca S, Perazella MA. Acute renal failure associated with tenofovir: evidence of drug-induced nephrotoxicity. *Am J Med Sci* 2002;324:342-4. (Abstract)
- Colle I, Adler M, Brenard R, et al. *Acta Gastroenterol Belg* 2007;70:389-420. (Abstract)
- Cornberg M, Protzer U, Petersen J, et al. Prophylaxis, diagnosis and therapy of hepatitis B virus infection - the German guideline. *Z Gastroenterol* 2011;49:871-930
- Craxi A, Cooksley WG. Pegylated interferons for chronic hepatitis B. *Antiviral Res.* 2003;60:87-9. (Abstract)
- Créput C, Gonzales-Canali G, Hill G, et al. Renal lesions in HIV-1-positive patient treated with tenofovir. *AIDS* 2003;17:935-7. (Abstract)
- Crespo J, Lozano JL, Echevarría S, et al. Influence of hepatitis C virus infection and human immunodeficiency on the natural history of chronic delta hepatitis. *Rev Esp Enferm Dig* 1994;85:185-91. (Abstract)
- European Association for the Study of the Liver. EASL Clinical Practice Guidelines: management of chronic hepatitis B. *J Hepatol* 2009;50:227-42.
- Feld JJ. HBV reactivation and cancer chemotherapy. 2010. Available at: <http://goo.gl/XB4ge>. Accessed December 1, 2011.
- Fleischer RD, Lok AS. Myopathy and neuropathy associated with nucleos(t)ide analog therapy for hepatitis B. *J Hepatol* 2009;51:787-91. (Abstract)
- Flink HJ, van Zonneveld M, Hansen BE, et al. Treatment with Peginterferon alpha-2b for HBeAg-positive chronic hepatitis B: HBSAg loss is associated with HBV genotype. *Am J Gastroenterol* 2006;101:297-303. (Abstract)
- Fried MW, Piratvisuth T, Lau GK, et al. HBeAg and hepatitis B virus DNA as outcome predictors during therapy with peginterferon alfa-2a for HBeAg-positive chronic hepatitis B. *Hepatology* 2008;47:428-34. (Abstract)
- Gane E, Jia J, Han K, et al. NEPTUNE study: on-treatment HBSAg level analysis confirms prediction of response observed in phase 3 study of peginterferon alfa-2a in HBeAg-positive patients. *J Hepatol* 2011;54:S31.
- Gallant JE, Parish MA, Keruly JC, Moore RD. Changes in renal function associated with tenofovir disoproxil fumarate treatment, compared with nucleoside reverse-transcriptase inhibitor treatment. *Clin Infect Dis* 2005;40:1194-8. (Abstract)
- Gaspar G, Monereo A, Garcia-Reyne A, de Guzman M. Fanconi syndrome and acute renal failure in a patient treated with tenofovir: a call to action. *AIDS* 2004;18:351-2. (Abstract)
- Gish RG, Lok AS, Chang TT, et al. Entecavir therapy for up to 96 weeks in patients with HBeAg-positive chronic hepatitis B. *Gastroenterology* 2007;133:1437-44. (Abstract)
- Gish RG, Chang TT, Lai CL, et al. Loss of HBSAg antigen during treatment with entecavir or lamivudine in nucleoside-naïve HBeAg-positive patients with chronic hepatitis B. *J Viral Hepat* 2010;17:16-22. (Abstract)
- Goncalves J, Laeufle R, Avila C. Increased risk with combination of telbivudine and pegylated-interferon Alfa-2A in study CLDT600A2406, compared to uncommon rate with telbivudine monotherapy from the novartis global database. *J Hepatol* 2009;50:A329.
- Hadziyannis S. Hepatitis B e antigen negative chronic hepatitis B: from clinical recognition to pathogenesis and treatment. *Viral Hepat Rev* 1995;1:7-13.
- Hadziyannis SJ, Vassilopoulos D. Hepatitis B e antigen-negative chronic hepatitis B. *Hepatology* 2001;34:617-24. (Abstract)
- Hadziyannis SJ, Tassopoulos NC, Heathcote EJ, et al. Adefovir dipivoxil for the treatment of hepatitis B e antigen-negative chronic hepatitis B. *N Engl J Med* 2003;348:800-7. (Abstract)

- Hadziyannis SJ, Tassopoulos NC, Heathcote EJ, et al. Long-term therapy with adefovir dipivoxil for HBeAg-negative chronic hepatitis B for up to 5 years. *Gastroenterology* 2006a;131:1743-51. ([Abstract](#))
- Hadziyannis SJ, Papatheodoridis GV. Hepatitis B e antigen-negative chronic hepatitis B: natural history and treatment. *Semin Liver Dis* 2006;26:130-41. ([Abstract](#))
- Hadziyannis SJ, Costamena A, Laras A, Hadziyannis E. Predictors/determinants of sustained virological response (SVR) and of HBsAg loss following long term adefovir dipivoxil (ADV) therapy in HBeAg-negative chronic hepatitis (CHB). Program and abstracts of the 59th Annual Meeting of the American Association for the Study of Liver Diseases; October 31 - November 4, 2008; San Francisco, California. Abstract 874.
- Han GR, Cao MK, Zhao W, et al. A prospective and open-label study for the efficacy and safety of telbivudine in pregnancy for the prevention of perinatal transmission of hepatitis B virus infection. *J Hepatol* 2011;55:1215-21. ([Abstract](#))
- Heathcote EJ, Marcellin P, Buti M, et al. Three-year efficacy and safety of tenofovir disoproxil fumarate treatment for chronic hepatitis B. *Gastroenterology* 2011;140:132-43. ([Abstract](#))
- Hou J, Yin YK, Xu D, et al. Telbivudine versus lamivudine in Chinese patients with chronic hepatitis B: Results at 1 year of a randomized, double-blind trial. *Hepatology* 2008;47:447-54. ([Abstract](#))
- Iloeje UH, Yang HI, Su J, et al. Predicting cirrhosis risk based on the level of circulating hepatitis B viral load. *Gastroenterology* 2006;130:678-86. ([Abstract](#))
- Janssen HL, van Zonneveld M, Senturk H, et al. Pegylated interferon alpha-2b alone or in combination with lamivudine for HBeAg-positive chronic hepatitis B: a randomised trial. *Lancet* 2005;365:123-9. ([Abstract](#))
- Juszczyk J, Boro?-Kaczmarek A, Cianciara J, et al. Antiviral treatment of chronic B hepatitis; 2010 - therapeutic recommendations. *Pol Merkuriusz Lekarski* 2010;29:103-6. ([Abstract](#))
- Karras A, Lafaurie M, Furco A, et al. Tenofovir-related nephrotoxicity in human immunodeficiency virus-infected patients: three cases of renal failure, Fanconi syndrome, and nephrogenic diabetes insipidus. *Clin Infect Dis* 2003;36:1070-3. ([Abstract](#))
- Keeffe EB, Zeuzem S, Koff RS, Dieterich DT, et al. Report of an international workshop: Roadmap for management of patients receiving oral therapy for chronic hepatitis B. *Clin Gastroenterol Hepatol* 2007;5:890-7. ([Abstract](#))
- Kumar M, Satapathy S, Monga R, et al. A randomized controlled trial of lamivudine to treat acute hepatitis B. *Hepatology* 2007;45:97-101. ([Abstract](#))
- Lai CL, Leung N, Teo EK, et al. Telbivudine Phase II Investigator Group. A 1-year trial of telbivudine, lamivudine, and the combination in patients with hepatitis B e antigen-positive chronic hepatitis B. *Gastroenterology* 2005;129:528-36. ([Abstract](#))
- Lai CL, Gane E, Liaw YF, et al. Telbivudine versus lamivudine in patients with chronic hepatitis B. *N Engl J Med* 2007;357:2576-88. ([Abstract](#))
- Lampertico P, Del Ninno E, Viganò M, et al. Long-term suppression of hepatitis B e antigen-negative chronic hepatitis B by 24-month interferon therapy. *Hepatology* 2003;37:756-63. ([Abstract](#))
- Lampertico P, Viganò M, Manenti E, et al. Low resistance to adefovir combined with lamivudine: a 3-year study of 145 lamivudine-resistant hepatitis B patients. *Gastroenterology* 2007;133:1445-51. ([Abstract](#))
- Lampertico P, Viganò M, Di Costanzo G, et al. Safety and tolerability of extended (96 weeks) treatment with peginterferon alfa-2a [40KD] in genotype D patients with HBeAg-negative chronic hepatitis B. *Hepatology* 2010;52:387A.
- Lampertico P, Viganò M, Facchetti F, et al. Effectiveness of entecavir for NUC-naive, HBeAg-negative chronic hepatitis B patients in clinical practice: A 2-year multicenter cohort study in 311 patients. Program and abstracts of the 45th Annual Meeting of the European Association for the Study of the Liver; April 14-18, 2010; Vienna, Austria. Abstract 1009.
- Lange CM, Bojunga J, Hofmann WP, et al. Severe lactic acidosis during treatment of chronic hepatitis B with entecavir in patients with impaired liver function. *Hepatology* 2009;50:2001-6. *B. Gastroenterology* 2009;136:486-95. ([Abstract](#))
- Lau GK, Piratvisuth T, Luo KX, et al. Peginterferon Alfa-2a, lamivudine, and the combination for HBeAg-positive chronic hepatitis B. *N Engl J Med* 2005;352:2682-95. ([Abstract](#))
- Lavanchy D. Hepatitis B virus epidemiology, disease burden, treatment, and current and emerging prevention and control measures. *J Viral Hepat* 2004;11:97-107. ([Abstract](#))

- Leung NJ. Entecavir (ETV) therapy in chronic hepatitis B patients previously treated with adefovir (ADV) with incomplete response on-treatment or relapse off-treatment. *Hepatology* 2009;50:S334.
- Leung N, Peng CY, Hann HW, et al. Early hepatitis B virus DNA reduction in hepatitis B e antigen-positive patients with chronic hepatitis B: A randomized international study of entecavir versus adefovir. *Hepatology* 2009a;49:72-9. ([Abstract](#))
- Leverro M, Cimino L, Lampertico P, et al. Tenofovir (TDF) for Chronic Hepatitis B Patients with Suboptimal Response to Adefovir (ADV) or ADV/LAM Treatment: Results of the OptiB Italian Multicenter Prospective Open Label Study. *Hepatology* 2010;52:96A.
- Liaw YF, Leung NW, Chang TT, et al. Effects of extended lamivudine therapy in Asian patients with chronic hepatitis B. Asia Hepatitis Lamivudine Study Group. *Gastroenterology* 2000;119:172-80. ([Abstract](#))
- Liaw YF, Leung N, Kao JH, et al. Chronic Hepatitis B Guideline Working Party of the Asian-Pacific Association for the Study of the Liver. Asian-Pacific consensus statement on the management of chronic hepatitis B: a 2008 update. *Hepatology* 2008;2:263-83. ([Abstract](#))
- Liaw YF, Gane E, Leung N, et al. 2-Year GLOBE trial results: telbivudine is superior to lamivudine in patients with chronic hepatitis B. *Gastroenterology* 2009;136:486-95. ([Abstract](#))
- Liaw YF, Chu CM. Hepatitis B virus infection. *Lancet* 2009;373:582-92. ([Abstract](#))
- Liaw YF, Sheen IS, Lee CM, et al. Tenofovir disoproxil fumarate (TDF), emtricitabine/TDF, and entecavir in patients with decompensated chronic hepatitis B liver disease. *Hepatology* 2011;53:62-72.
- Lok AS, Lai CL, Leung N, et al. Long-term safety of lamivudine treatment in patients with chronic hepatitis B. *Gastroenterology* 2000;119:172-80.
- Lok AS, McMahon BJ. Chronic hepatitis B. *Hepatology* 2007 ;45:507-39. ([Abstract](#))
- Lok AS, McMahon BJ. Chronic Hepatitis B: Update 2009. *Hepatology* 2009;50:1-35.
- Manesis EK, Hadziyannis SJ. Interferon alpha treatment and retreatment of hepatitis B e antigen-negative chronic hepatitis B. *Gastroenterology* 2001;121:101-9. ([Abstract](#))
- Manns MP, Akarca US, Chang TT, et al. Long-term safety and tolerability of entecavir in patients with chronic hepatitis B in the rollover study ETV-901. *Expert Opin Drug Saf* 2012. In press. ([Abstract](#))
- Marcellin P, Lau GK, Bonino F, et al. Peginterferon a-2a alone, lamivudine alone, and the two in combination in patients with HBeAg-negative chronic hepatitis B. *N Engl J Med* 2004;351:1206-17. ([Abstract](#))
- Marcellin P, Bonino F, Lau GK, et al. Sustained response of hepatitis B e antigen-negative patients 3 years after treatment with peginterferon a-2a. *Gastroenterology* 2009a;136:2169-79. ([Abstract](#))
- Marcellin P, Piratvishut T, Brunetto MR, et al. A finite course of peginterferon alfa-2a results in inactive chronic hepatitis B and HBsAg clearance 5 years post-treatment in patients with HBeAg-negative disease: baseline characteristics and predictive factors of long-term response. 60th Annual Meeting of the American Association for the Study of Liver Diseases (AASLD 2009). Boston 2009b, Abstract 387.
- Marcellin P, Buti M, Gane EJ, et al. Five years of treatment with tenofovir DF (TDF) for chronic hepatitis B (CHB) infection is associated with sustained viral suppression and significant regression of histological fibrosis and cirrhosis. *Hepatology* 2011;54:1011A.
- Marcellin P, Heathcote J, Buti M, et al. Characterization of HBsAg seroconversion in patients with chronic hepatitis B (CHB) treated with tenofovir disoproxil fumarate (TDF). *Hepatology* 2011;54:1036A.
- Mauss S, Berger F, Filmann N, et al. Effect of HBV polymerase inhibitors on renal function in patients with chronic hepatitis B. *J Hepatol* 2011;55:1235-40. ([Abstract](#))
- McMahon BJ, Alward WL, Hall DB, et al. Acute hepatitis B virus infection: relation of age to the clinical expression of disease and subsequent development of the carrier state. *J Infect Dis* 1985;151:599-603. ([Abstract](#))
- Mommeja-Marin H, Mondou E, Blum MR, Rousseau F. Serum HBV DNA as a marker of efficacy during therapy for chronic HBV infection: analysis and review of the literature. *Hepatology* 2003;37:1309-19. ([Abstract](#))
- Moses SE, Lim ZY, Sudhanva M, et al. Lamivudine prophylaxis and treatment of hepatitis B virus-exposed recipients receiving reduced intensity conditioning hematopoietic stem cell transplants with alemtuzumab. *J Med Virol* 2006;78:1560-3. ([Abstract](#))

- Moucari R, Mackiewicz V, Lada O, et al. Early serum HBsAg drop: a strong predictor of sustained virological response to pegylated interferon  $\alpha$ -2a in HBeAg-negative patients. *Hepatology* 2009;49:1151-7. ([Abstract](#))
- Moucari R, Korevaar A, Lada O, et al. High rates of HBsAg seroconversion in HBeAg-positive chronic hepatitis B patients responding to interferon: a long-term follow-up study. *J Hepatol* 2009;50:1084-92. ([Abstract](#))
- Ning Q, Han MF, Sun YT, et al. Patients with HBeAg-positive chronic hepatitis B with a maintained virologic response to entecavir achieved HBsAg clearance when switched to peginterferon  $\alpha$ -2a (40KD) therapy (the OSST study). *Hepatology* 2011;54:1010A.
- Papatheodoridis GV, Manolakopoulos S, Touloumi G, et al. Virological suppression does not prevent the development of hepatocellular carcinoma in HBeAg-negative chronic hepatitis B patients with cirrhosis receiving oral antiviral(s) starting with lamivudine monotherapy: results of the nationwide HEPNET. Greece cohort study. *Gut* 2011;60:1109-16.
- Park JW, Park KW, Cho SH, et al. Risk of hepatitis B exacerbation is low after transcatheter arterial chemoembolization therapy for patients with HBV-related hepatocellular carcinoma: report of a prospective study. *Am J Gastroenterol* 2005;100:2194-200. ([Abstract](#))
- Perrillo RP, Lai CL, Liaw YF, et al. Predictors of HBeAg loss after lamivudine treatment for chronic hepatitis B. *Hepatology* 2002;36:186-94. ([Abstract](#))
- Perrillo RP, Schiff ER, Davis GL, et al. A randomized, controlled trial of interferon  $\alpha$ -2b alone and after prednisone withdrawal for the treatment of chronic hepatitis B. *N Engl J Med* 1990;323:295-301. ([Abstract](#))
- Petersen J, Ratziu V, Buti M, et al. Entecavir plus tenofovir combination as rescue therapy in pre-treated chronic hepatitis B patients: An international multicenter cohort study. *J Hepatol* 2011 26. *J Hepatol* 2011 Oct 26. [Epub ahead of print] ([Abstract](#))
- Peyriere H, Reynes J, Rouanet I, et al. Renal tubular dysfunction associated with tenofovir therapy: report of 7 cases. *J Acquir Immune Defic Syndr* 2004;35:269-73. ([Abstract](#))
- Rehermann B, Ferrari C, Pasquinelli C, Chisari FV. The hepatitis B virus persists for decades after patients' recovery from acute viral hepatitis despite active maintenance of a cytotoxic T-lymphocyte response. *Nat Med* 1996;2:1104-8. ([Abstract](#))
- Reijnders JG, Pas SD, Schutten M, et al. Entecavir shows limited efficacy in HBeAg-positive hepatitis B patients with a partial virologic response to adefovir therapy. *J Hepatol* 2009;50:674-83. ([Abstract](#))
- Reijnders JG, de Vries-Sluijs T, Hansen BE, et al. Five years tenofovir therapy is associated with maintained virologic response, but significant decline in renal function in HIV/HBV coinfecting patients. 60th Annual Meeting of the American Association for the Study of Liver Diseases (AASLD 2009). Boston 2009a. Abstract 425.
- Roche B, Samuel D. The difficulties of managing severe hepatitis B virus reactivation. *Liver Int* 2011;31:104-10. ([Abstract](#))
- Rutgeerts P, Vermeire S, Van Assche G. Biological therapies for inflammatory bowel diseases. *Gastroenterology*. 2009;136:1182-97. ([Abstract](#))
- Schiff ER, Lee SS, Chao YC, et al. Long-term treatment with entecavir induces reversal of advanced fibrosis or cirrhosis in patients with chronic hepatitis B. *Clin Gastroenterol Hepatol*. 2011;9:274-6. ([Abstract](#))
- Sherman M, Yurdaydin C, Simsek H, et al. Entecavir therapy for lamivudine-refractory chronic hepatitis B: improved virologic, biochemical, and serology outcomes through 96 weeks. *Hepatology* 2008;48:99-108.
- Seto WK, Lai CL, Fung J, et al. Significance of HBV DNA levels at 12 weeks of telbivudine treatment and the 3 years treatment outcome. *J Hepatol* 2011;55:522-8. ([Abstract](#))
- Snow-Lampart A, Chappell B, Curtis M, et al. No resistance to tenofovir disoproxil fumarate detected after up to 144 weeks of therapy in patients monoinfected with chronic hepatitis B virus. *Hepatology* 2011;53:763-73.
- Sonneveld MJ, Rijckborst V, Boucher CA, et al. Prediction of sustained response to peginterferon  $\alpha$ -2b for hepatitis B e antigen-positive chronic hepatitis B using on-treatment hepatitis B surface antigen decline. *Hepatology* 2010;52:1251-7.
- Sung JJ, Lai JY, Zeuzem S, et al. Lamivudine compared with lamivudine and adefovir dipivoxil for the treatment of HBeAg-positive chronic hepatitis B. *J Hepatol* 2008;48:728-35. ([Abstract](#))

- ter Borg MJ, Leemans WF, de Man RA, Janssen HL. Exacerbation of chronic hepatitis B infection after delivery. *J Viral Hepat* 2008;15:37-41. ([Abstract](#))
- Tillmann HL, Hadem J, Leifeld L, et al. Safety and efficacy of lamivudine in patients with severe acute or fulminant hepatitis B, a multicenter experience. *J Viral Hepat* 2006;13:256-63. ([Abstract](#))
- Tenney DJ, Rose RE, Baldick CJ, et al. Long-term monitoring shows hepatitis B virus resistance to entecavir in nucleoside-naïve patients is rare through 5 years of therapy. *Hepatology* 2009;49:1503-14. ([Abstract](#))
- Toy M, Veldhuijzen IK, de Man RA, et al. Potential impact of long-term nucleoside therapy on the mortality and morbidity of active chronic hepatitis B. *Hepatology* 2009;50:743-751. ([Abstract](#))
- van Bömmel F, Trojan J, Feucht HH, et al. Tenofovir shows limited efficacy in treatment of HBV infections resistant against adefovir. *Hepatology* 2007;46:664A.
- van Bömmel F, de Man RA, Wedemeyer H, et al. Long-term efficacy of tenofovir monotherapy for hepatitis B virus-monoinfected patients after failure of nucleoside/nucleotide analogues. *Hepatology* 2010;51:73-80. ([Abstract](#))
- van Zonneveld M, van Nunen AB, Niesters HG, et al. Lamivudine treatment during pregnancy to prevent perinatal transmission of hepatitis B virus infection. *J Viral Hepat* 2003;10:294-7. ([Abstract](#))
- Verhelst D, Monge M, Meynard JL, et al. Fanconi syndrome and renal failure induced by tenofovir: a first case report. *Am J Kidney Dis* 2002;40:1331-3. ([Abstract](#))
- Vassilopoulos D, Calabrese LH. Risks of immunosuppressive therapies including biologic agents in patients with rheumatic diseases and co-existing chronic viral infections. *Curr Opin Rheumatol*. 2007;19:619-25. ([Abstract](#))
- Waked I, Salama M, Zayed N, et al. Egyptian Guidelines 2008.
- Werle-Lapostolle B, Bowden S, Locarnini S, et al. Persistence of cccDNA during the natural history of chronic hepatitis B and decline during adefovir dipivoxil therapy. *Gastroenterology*. 2004;126:1750-8. ([Abstract](#))
- Wiegand J, Wedemeyer H, Finger A, et al. A decline in hepatitis B virus surface antigen (HBsAg) predicts clearance, but does not correlate with quantitative HBeAg or HBV DNA levels. *Antivir Ther* 2008;13:547-54.
- Wong DK, Cheung AM, O'Rourke K, et al. Effect of alpha-interferon treatment in patients with hepatitis B e antigen-positive chronic hepatitis B. A meta-analysis. *Ann Intern Med* 1993;119:312-23. ([Abstract](#))
- Wursthorn K, Lutgehetmann M, Dandri M, et al. Peginterferon alpha-2b plus adefovir induce strong cccDNA decline and HBsAg reduction in patients with chronic hepatitis B. *Hepatology* 2006;44:675-84. ([Abstract](#))
- Yu JW, Sun LJ, Zhao YH, et al. The Study of Efficacy of Lamivudine in Patients with Severe Acute Hepatitis B. *Dig Dis Sci* 2010;55:775-83. ([Abstract](#))
- Yuen MF, Fong DY, Wong DK, et al. Hepatitis B virus DNA levels at week 4 of lamivudine treatment predict the 5-year ideal response. *Hepatology* 2007;46:1695-1703. ([Abstract](#))
- Zeuzem S, Gane E, Liaw YF, et al. Baseline characteristics and early on-treatment response predict the outcomes of 2 years of telbivudine treatment of chronic hepatitis B. *J Hepatol* 2009;51:11-20. ([Abstract](#))
- Zoulim F, Perrillo R. Hepatitis B: reflections on the current approach to antiviral therapy. *J Hepatol* 2008;48:S2-S19. ([Abstract](#))

## 10. Management of Resistance in HBV Therapy

*Stefan Mauss and Heiner Wedemeyer*

### Introduction

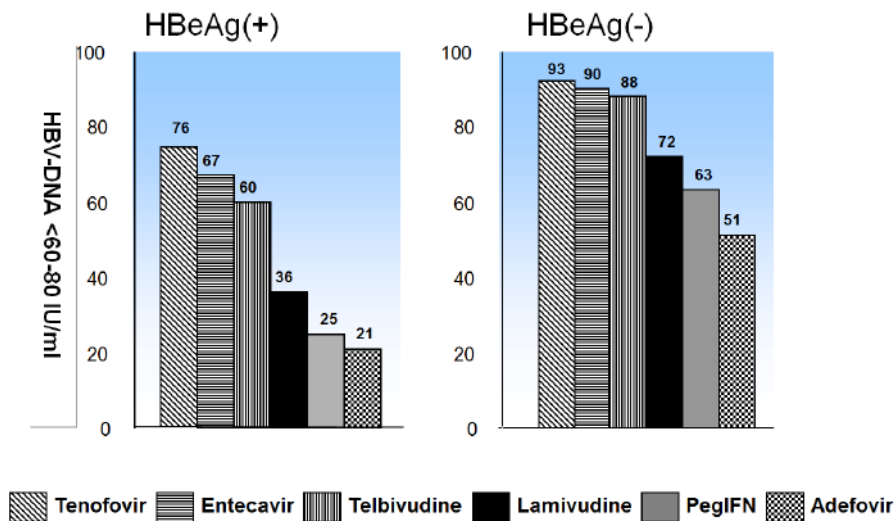
Interferon monotherapy has been the standard of care for chronic hepatitis B since the mid-1990s. Primary resistance to interferon presents as lack of HBe or HBs antigen loss or seroconversion. Interferon-induced immune control of HBV is less frequently reported for HBV genotypes B, C and D than for HBV genotype A (Erhardt 2005, Flink 2006). However, the development of resistance mutations to interferon while on therapy has not been reported to date. Recently, in patients with chronic hepatitis C, a genetic polymorphism at locus IL28B has been identified as a host factor associated with response to interferon-based therapy (Ge 2009). If similar host factors exist for response to interferon therapy in chronic hepatitis B, they are not known. However, a recent paper did demonstrate an association of the natural history of hepatitis B infection and genetic variants in the HLA-DP locus (Kamatami 2009).

Since the introduction of lamivudine, treatment of chronic hepatitis B has been characterised by a rapid increase in the number of available antiviral drugs, all belonging to the class of HBV polymerase inhibitors (Figure 1). Due to better tolerance and more convenient administration compared to interferon, HBV polymerase inhibitors today account for the vast majority of prescribed therapies for chronic hepatitis B in Western countries. However, due to the slow kinetics of immune control, long-term suppression of HBV is needed, particularly in HBeAg-negative patients harbouring the precore mutant. This is due to the high relapse rate after discontinuation of antiviral therapy in patients with precore mutants in the absence of HBs antigen seroconversion. HBs antigen seroconversion is a rare event in the first years of treatment.

For this reason, the understanding of resistance and cross-resistance of HBV polymerase inhibitors is relevant in long-term treatment strategies. Suboptimal antiviral therapy resulting in the development of early resistance will harm future treatment options and lead to progressive liver disease, especially in those with



limited treatment options (Brunelle 2005, Kurashige 2009). In addition, some HBV polymerase variants may interact with immunologically relevant epitopes of the envelope resulting in immune escape mutants. These mutants may be able to successfully infect vaccinated individuals. Although this finding is currently an *in vitro* observation, any confirmation of this phenomenon in patients will result in a serious public health concern, particularly in countries with a high prevalence of hepatitis B.



**Figure 1. Proportion of patients with undetectable HBV DNA after 48 or 52 weeks of treatment.** Data does not represent “head-to-head” trials (based on Heathcote 2007, Lai 2006, Liaw 2009, Marcellin 2003, Marcellin 2007).

## Antiviral HBV therapy – how to avoid resistance

Treatment of HBV is relatively safe and easy compared to hepatitis C treatment or HIV therapy. But avoiding the induction of resistance is one of the critical efforts that need to be made by physicians and patients. They need to choose the right therapy and monitoring schedule, and pay close attention to good adherence.

Entecavir and tenofovir have proven efficacy and very little or no resistance in treatment-naïve patients in the first years of therapy (Heathcote 2011, Yuen 2011). In patients with limited HBV replication, telbivudine has also shown good results, although in patients with high viral load treatment results can be compromised by the development of resistance, also true for adefovir and lamivudine (Zeuzem 2009).

As previously stated, treating patients for longer periods with HBV polymerase inhibitors can result in the development of viral resistance – particularly in patients with less than optimal viral suppression (Lai 2006). In particular, lamivudine and telbivudine are prone to developing resistance rapidly. Therapy with HBV polymerase inhibitors needs to fully suppress viral replication (HBV DNA <math><300\text{ copies/ml}</math>). HBV DNA should be monitored after the first 4-6 weeks of therapy to assess adherence and then every 3-6 months while on therapy. If complete viral

suppression determined by an ultrasensitive assay is not achieved on monotherapy within the first 6 months on lamivudine, telbivudine or adefovir, treatment should be switched to tenofovir or entecavir. In patients on either tenofovir or entecavir, combination therapy with non-cross-resistant HBV polymerase inhibitors may be considered after 12 months in case a plateau of viral replication is reached. There is only one study to date showing a stronger efficacy of combination therapy in patients with high viral load comparing entecavir monotherapy with entecavir plus tenofovir (Lok 2011). For tenofovir the benefit of adding a second drug has not been assessed prospectively.

Resistance to nucleoside polymerase inhibitors, i.e., lamivudine, telbivudine, emtricitabine or entecavir, eliminates or markedly reduces antiviral efficacy of all other nucleosides and may affect even nucleotide polymerase inhibitors due to cross-resistance.

Resistance can also be associated with significant flares of hepatitis and has been associated with a higher rate of clinical complications in one Asian study (Liaw 2004) and with a lower overall survival in an Italian cohort (DiMarco 2004). Therefore, resistance needs to be avoided, particularly in patients with liver cirrhosis. Based on these severe consequences of treatment failure, we would recommend selecting a drug with a high genetic barrier for antiviral resistance in cirrhotic individuals.

## Treatment endpoints

In HBe antigen-positive patients infected with wild-type HBV strains HBeAg seroconversion has been shown to be associated with a reduction in liver-associated morbidity and increased survival (Niederau 1996). Thus, HBe antigen seroconversion is considered a clinical endpoint in this patient population and discontinuation of HBV polymerase inhibitors is recommended 6-12 months after HBe antigen seroconversion in those who have not developed liver cirrhosis (Cornberg 2007). HBe antigen loss is reported in up to 50% of patients treated with HBV polymerase inhibitors after prolonged periods – several years - of therapy (Hadziyannis 2006). Recent cohort data sheds some doubt on the durability of HBe antigen seroconversion via therapy with polymerase inhibitors, with reported relapse rates of about 50%, which is considerably higher than with interferon-induced HBe antigen seroconversion (Reijnders 2010).

Treatment with pegylated interferon alfa-2a for 48 weeks results in HBe antigen seroconversion and a very low relapse rate in about a third of patients (Lau 2005).

Discontinuation of HBV polymerase inhibitor therapy in patients without HBe antigen seroconversion usually results in relapse of chronic hepatitis B. With interferon, the situation may become more complex and is at least partially dependent on the HBV genotype in addition to the HBe antigen status (Erhardt 2005, Erhardt 2010).

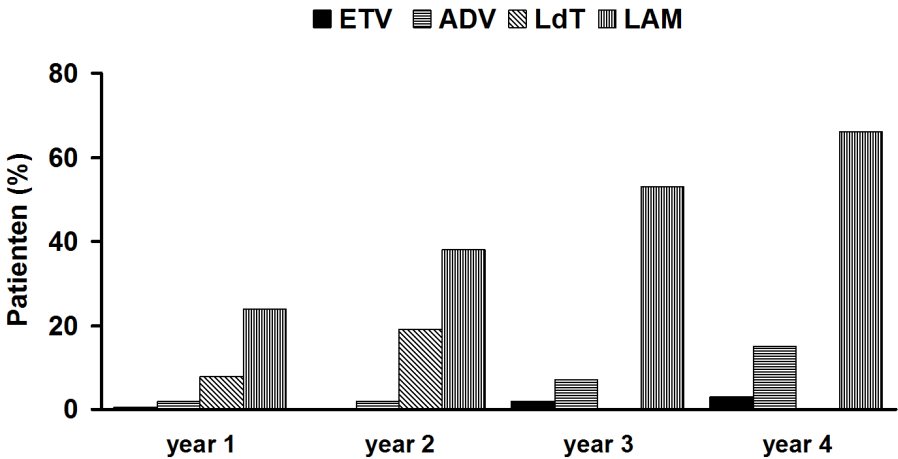
HBV polymerase inhibitors treatment endpoints in HBe antigen-negative hepatitis B in most cases are restricted to sustained normalisation of ALT levels, suppression of HBV DNA and improvement in liver histology, as HBs antigen seroconversion is rare with current treatment options. Consequently, treatment duration and endpoints are more difficult to define in these patients. Reappearance of HBV DNA after stopping HBV polymerase inhibitor treatment is observed in almost all patients,

even after fully suppressive treatment for multiple years (Marcellin 2004, Petersen 2011). Most guidelines therefore recommend indefinite treatment of HBe antigen-negative patients without HBs antigen seroconversion.

PEG-IFN  $\alpha$ -2a has also been studied in HBe antigen-negative hepatitis B leading to a 6-month off-treatment response (HBV DNA <400 copies/ml) in up to 20% of patients (Marcellin 2004). HBs antigen seroconversion happens in about 5% of patients after a year of treatment with PEG-IFN. In addition, about 20% of patients reach a low replicative status of their chronic hepatitis B, at least temporarily, after interferon discontinuation (Bonino 2007). After an observational period of five years after one year of interferon-based therapy, the seroconversion rate increases to 12% (Marcellin 2009). For HBV polymerase inhibitors HBs antigen seroconversion has been reported for HBe antigen negative patients in less than 5% of patients in published prospective studies.

## Resistance patterns of HBV polymerase inhibitors

Lamivudine was the first approved HBV polymerase inhibitor. It is characterized by good clinical tolerability, moderate antiviral efficacy and rather quick development of resistance in cases of not fully suppressive antiviral therapy (Figure 2). Within the first year of therapy up to 20% of patients may develop mutations in the YMDD motif associated with loss of activity against HBV. About 70-80% of patients without HBe antigen seroconversion develop lamivudine-resistant variants after four or more years of therapy (Figure 2).

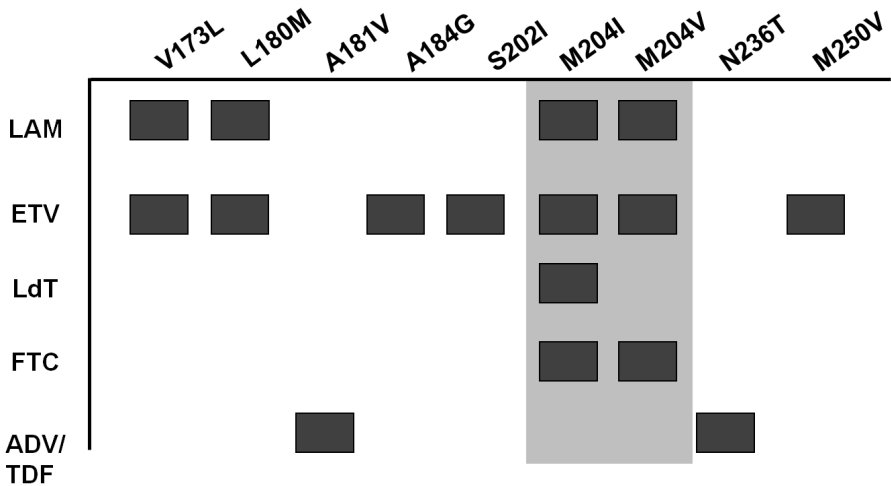


**Figure 2. Cumulative incidence of HBV polymerase inhibitor resistance. These numbers are average estimates based on numerous studies.** Resistance rates differ between trials and cohorts. Overall, resistance rates have been higher in HBe antigen-positive patients than in HBe antigen-negative patients. Long-term data for adefovir has only been reported for HBe antigen-negative patients and thus resistance rates may be even higher for HBe antigen-positive individuals. Data for entecavir is biased since both patients with best responses (e.g., HBe antigen seroconversion) and patients with suboptimal virological responses (>700,000 copies/ml after one year of treatment) were withdrawn from the study.

Lamivudine mutations confer cross-resistance to telbivudine, emtricitabine and entecavir. Preliminary data indicate that the development of multiple lamivudine-associated mutations may even reduce the efficacy of tenofovir therapy (Lada 2008).

Emtricitabine has comparable antiviral properties and a similar resistance profile to lamivudine (Lim 2006). However it is only approved as an antiretroviral medication for HIV, not for treatment of chronic hepatitis B. In HBV, its use is mainly limited as part of combination therapy with tenofovir in HIV-coinfected patients with an indication for antiretroviral therapy.

Telbivudine has shown superior antiviral efficacy compared to lamivudine in HBe antigen-positive and -negative patients. However, development of resistance is considerable in naïve patients with highly replicative hepatitis B and the resistance pattern is essentially the same as that of lamivudine, resulting in complete cross-resistance of the two compounds (Liaw 2009, Zeuzem 2009) (Table 1). Outcomes are better and antiviral efficacy more sustained in patients with an HBV DNA of less than  $10^6$  IU/ml (Zeuzem 2009). Combination therapy of telbivudine and lamivudine does not improve the antiviral efficacy nor does it delay the development of resistance compared to telbivudine monotherapy (Lai 2005).



**Figure 3. Resistance patterns of different antiviral drugs used for the treatment of chronic hepatitis B.** The numbers indicate the respective amino acid position in the HBV polymerase gene. For entecavir, resistance at positions 204/180 plus an additional mutation at position 184, 202 or 250 is required to lead to clinically significant drug resistance. Most but not all variants have been shown to be associated with drug resistance both *in vitro* and *in vivo*.

Adefovir was the second approved HBV polymerase inhibitor. It has full activity in lamivudine-resistant patients. However, its antiviral potency is limited by its nephrotoxicity. Due to tubular damage of the kidney, the approved dose is limited to 10 mg/day, although 30 mg/day showed superior antiviral efficacy (Marcellin 2003). The reduced antiviral potency is counterbalanced, however, by a favourable resistance profile. Development of resistance occurs later and to a lesser extent compared to lamivudine or telbivudine (Figure 3), although resistance to adefovir

may occur more often in patients with pre-existing lamivudine resistance (Lee 2006). No association of response to treatment with HBV genotypes was evident in the registrational trials (Westland 2003).

**Table 1. Recommendations in secondary treatment failure of HBV polymerase inhibitors.**

Resistance against nucleoside analogs	Recommended therapeutic option
Lamivudine	Tenofovir, adefovir*
Telbivudine	Tenofovir, adefovir*
Entecavir	Tenofovir, adefovir*
Resistance against nucleotide analogs	Recommended therapeutic option
Adefovir (LAM-naïve)	Entecavir, tenofovir, (telbivudine), (lamivudine)
Adefovir (LAM-resistant)	tenofovir
Tenofovir (no <i>in vivo</i> data available)	Entecavir, (telbivudine), (lamivudine)

\*in case tenofovir is not available

Adefovir-resistant or non-responding HBV strains seem to respond to tenofovir with a slower viral decline, but without signs of true cross-resistance (Berg 2008, Van Bömmel 2010). Adefovir resistant strains respond fully to entecavir therapy (Reijnders 2010).

The combination of adefovir plus lamivudine in the presence of lamivudine resistance delays the development of adefovir resistance considerably compared to switching to adefovir monotherapy (Lampertico 2006, Lampertico 2007).

Entecavir is an HBV nucleoside polymerase inhibitor with good antiviral efficacy and slow development of resistance in treatment-naïve patients (Chang 2006, Lai 2006, Lampertico 2009). This is due to the fact that more than one mutation in the HBV polymerase gene is required to confer resistance to entecavir. However, entecavir shares some resistance mutations with lamivudine and telbivudine. The presence of lamivudine resistance mutations at L180M, M204I, L180M + M204V facilitates the development of resistance to entecavir because only one additional mutation is required for the development of full resistance. As a result, in contrast to treatment of naïve patients where entecavir is clearly superior to lamivudine, its antiviral potency is markedly reduced in patients with lamivudine resistance and up to 40% of lamivudine-resistant patients develop full entecavir resistance after 3 years of treatment (Tenney 2007, Colonna 2007).

Patients with resistance only to adefovir have favourable treatment results with entecavir, while patients with combined adefovir and lamivudine resistance do not respond well to entecavir monotherapy (Reijnders 2007, Nguyen 2009, Chloé 2009, Shim 2009).

Tenofovir is approved for the treatment of HIV and HBV. Early data from HBV/HIV-coinfected patients showed a strong antiviral potency and slow development of resistance (Núñez 2002, Nelson 2003, van Bommel 2004). In its registrational trials, tenofovir was superior to adefovir resulting in substantially higher rates of full viral suppression in HBe antigen-positive (tenofovir 69% vs. adefovir 9%, HBV DNA <40 IU/ml) and HBe antigen-negative patients (tenofovir 91% vs. adefovir 56% HBV DNA <40 IU/ml) at 52 weeks of therapy (Heathcote 2009, Marcellin 2008). In

HIV-positive patients, anecdotal cases of renotubular dysfunction were reported. Otherwise tenofovir is well-tolerated. It is active in lamivudine-resistant patients (Schmutz 2006, Manns 2009). So far, no obvious resistance patterns to tenofovir associated with antiviral failure in trials and cohorts have been observed (Snow-Lampart 2010).

The acquisition of adefovir resistance mutations and multiple lamivudine resistance mutations may impair the activity of tenofovir (Fung 2005, Lada 2008, van Bömmel 2010), although even in these situations tenofovir retains activity against HBV (Berg 2008, Petersen 2009).

## Combination therapy of chronic hepatitis B to delay development of resistance

Combination therapy is thought to be superior to monotherapy, particularly in patients with highly replicative hepatitis B (HBV DNA  $>10^9$  copies/ml). However, so far the response rate in trials assessing the long-term efficacy of tenofovir and entecavir show a long-acting antiviral effect even in patients with high viral load and little to no development of resistance (Snow-Lampart 2011). Trials assessing *de novo* combination therapy versus monotherapy are limited. The experience with combining telbivudine and lamivudine suggests that combinations of two nucleoside analogs with an overlapping resistance profile do not have an additive antiviral effect (Lai 2005). In contrast, combining a nucleoside with a nucleotide polymerase inhibitor with different resistance profiles may be of benefit (Sung 2008, Lok 2011). Trials that will provide more evidence on how to best use the current antiviral options are currently underway or are being designed. However, these trials may require larger patient numbers than currently included and may need longer observational periods due to agents like entecavir and tenofovir having such considerable efficacy as monotherapy. However, it should be remembered that – in contrast to HIV – immune control of HBV is possible, limiting the duration of therapy in particular in HBe antigen-positive patients. With the availability of HBV polymerase inhibitors with high resistance barriers, even treatment-naïve patients with high levels of HBV replication should be treated initially with one drug. In patients with considerable viral replication despite good adherence a possible option is to add a non-cross-resistant drug in order to maximise viral suppression and to avoid development of resistance.

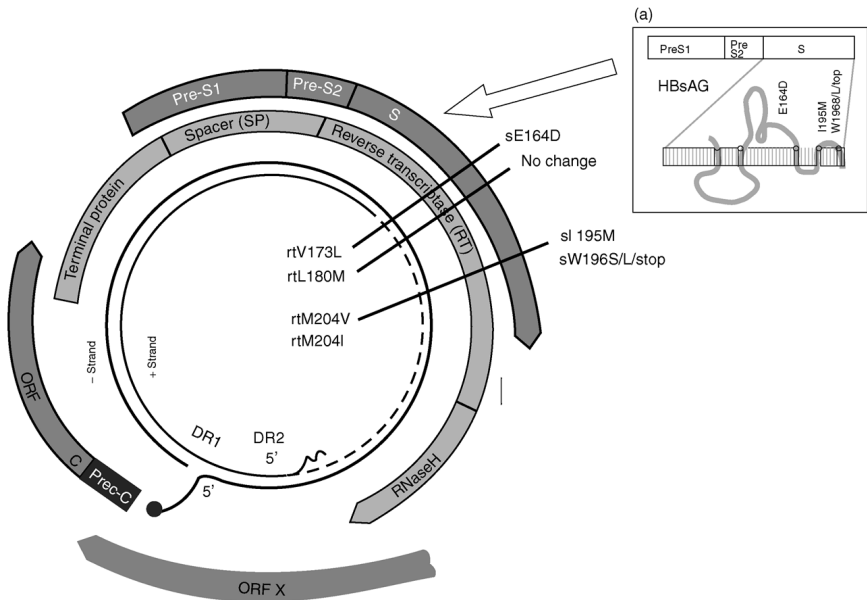
## Management of drug resistance

Primary and secondary treatment failure has to be distinguished in the treatment of hepatitis B. A clinically sufficient primary response after 6 months is defined by a reduction of HBV DNA to at least  $<10^3$  copies/ml (200 IU/ml) or by a continuous drop of HBV DNA through month 12. In contrast, if a rise in HBV DNA by one log or more is observed while on antiviral therapy, a secondary resistance or non-adherence is very likely to be present. HBV resistance usually arises several months before biochemical relapse with elevation of transaminases, thus regular HBV DNA monitoring is required during antiviral therapy (e.g., every 3 months) (Cornberg 2007). Testing for variants associated with resistance might be useful if HBV DNA levels rise during treatment.

Most viral breakthroughs in treatment-naïve patients on entecavir or tenofovir are the result of adherence issues. Therefore, patient adherence should be assessed before genotypic resistance testing is done.

Additional compensatory mutations can develop if monotherapy is continued despite HBV resistance, thereby broadening the possibilities of cross-resistance (Locarnini 2004). Knowledge of the antiviral efficacy, the resistance barrier, and the resistance profile of each available oral antiviral is a prerequisite for the rational use of nucleos(t)ide analogs for hepatitis B. In the case of resistance to a nucleoside analog (lamivudine, telbivudine, emtricitabine, entecavir), early replacement by tenofovir or add-on treatment with adefovir (if tenofovir is not available) is recommended. In the opposite scenario, a nucleoside addition to current nucleotide treatment should happen if adefovir or tenofovir treatment failure begins to occur (Figure 4). In the case of adefovir, switching from adefovir to tenofovir should be assessed as an additional measure.

Historically, most data generated has been from patients with lamivudine resistance. In this setting the advantage of adding adefovir rather than switching to adefovir is well-established (Lampertico 2005, Lampertico 2007). Moreover, adefovir should be added early at low HBV DNA levels, when a rise in HBV DNA has been confirmed but before a biochemical relapse has occurred. Today, the most appropriate strategy may be a switch to tenofovir with or without continuation of lamivudine (Manns 2009).



**Figure 4. Mutations in the HBV polymerase.** Due to the overlapping reading frame between HBV polymerase and envelope sequences, mutations in the HBV polymerase, in particular at codons 173, 180 and 204, may lead to changes in the conformation of immunodominant domains of the HBV envelope.

## Special considerations in HIV/HBV coinfection

In patients with chronic hepatitis B and HIV coinfection, the first question to ask is if there is an indication for antiretroviral therapy. In patients with no such indication interferon or an HBV polymerase inhibitor without HIV activity are options. The initially recommended monotherapy with entecavir is now considered obsolete – the anti-HIV activity of entecavir has been described (M184V) in anecdotal cases (MacMahon 2007). Currently, adefovir and telbivudine are recommended, based on limited *in vivo* data for adefovir or *in vitro* data and some anecdotal case reports for telbivudine (Delaugerre 2002, Sheldon 2005, Avilla 2009, Milazzo 2009). As both drugs have limitations in the setting of HBV-monoinfected patients the initiation of antiretroviral therapy allowing the use of tenofovir plus lamivudine/emtricitabine should be considered, in particular in patients with advanced liver fibrosis.

In patients with an indication for antiretroviral therapy, a regimen containing tenofovir with or without lamivudine or emtricitabine is favored in order to avoid development of lamivudine or emtricitabine resistance in HBV. The incidence of HBV resistance in patients treated with lamivudine after two years is about 50% in HIV/HBV-coinfected patients (Benhamou 1999). In patients who have already developed lamivudine-resistant HBV, tenofovir should be added to or replace lamivudine for HBV treatment (Schmutz 2006). Whether entecavir should be added in patients on tenofovir +/- emtricitabine/lamivudine or replace tenofovir in case of renal impairment should be decided on an individual basis (Ratliffe 2011).

A change of antiretroviral regimen in HBV/HIV-coinfected patients due to the development of HIV resistance must take the HBV infection into consideration, as the chronic hepatitis B may be exacerbated in the absence of an active HBV polymerase inhibitor.

More information on this topic can be found in Chapter 17.

## Immune escape and polymerase inhibitor resistance

Another relevant but unexpected consequence of lamivudine resistance is the induction of conformational changes in the HBs antigen due to an overlapping reading frame in the genetic sequence of the HBV polymerase and the HBs antigen (Figure 4). Because of this, mutations in the HBV polymerase may induce changes in the envelope of the virus resulting in an altered immunogenicity. This may result in vaccine escape mutants. *In vitro* and *ex vivo* studies support this hypothesis, which may have important public health implications (Mathews 2006, Sheldon 2007). Studies in chimpanzees have indeed confirmed that infections with drug-induced HBV variants are possible despite the presence of high anti-HBs levels that were considered protective in the vaccinated host (Kamili 2009).

In addition to humoral escape, lamivudine resistance may also affect cellular immunity against HBV. As mentioned earlier, suboptimal antiviral therapy, e.g., with lamivudine, especially in high prevalence countries, could undermine the success of vaccination efforts leading to a spread of HBV vaccine escape mutants.

The YMDD motif is also part of an MHC class I restricted CTL epitope. YMDD-specific cytotoxic T lymphocytes may partially cross-react with YVDD and YIDD variants (Lin 2005) and thereby contribute to a prevention of emergence of

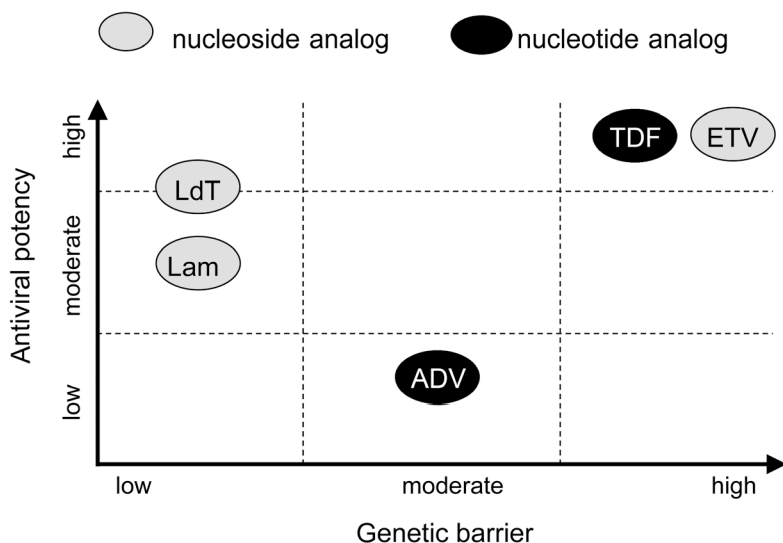


resistance. However, more studies are needed to explore in detail the consequences of the development of viral resistance to polymerase inhibitors for T cell immunity against HBV.

## Conclusion

In summary, therapy with HBV polymerase inhibitors to date is limited to two active subclasses with different resistance profiles. Resistance due to suboptimal treatment, i.e., on only one drug, can eliminate or reduce the effect of other drugs due to partial or complete cross-resistance. This sequence is well documented for lamivudine, telbivudine and entecavir. The superiority of *de novo* combination therapy for HBV over sequential monotherapy may be likely for patients with very high HBV viremia, but still has to be confirmed in well-designed prospective clinical trials. In patients with low or intermediate viremia, the risk for development of resistance is rather low when using drugs with a high genetic barrier and when a rapid suppression of HBV replication is achieved (Figure 5).

The choice of first-line treatment strategy will determine future treatment options; being judicious is paramount, as suboptimal therapeutic approaches can result in a rapid exhaustion of options within just a few years.



**Figure 5. Antiviral potency and genetic resistance barrier of currently approved HBV polymerase inhibitors.**

## References

- Benhamou Y, Bochet M, Thibault V, Di Martino V, Caumes E, Bricaire F, et al. Long-term incidence of hepatitis B virus resistance to lamivudine in human immunodeficiency virus-infected patients. *Hepatology*. 1999;30(5):1302-6. ([Abstract](#))
- Berg T, Moller B, Trinh H, Chan S, Marcellin P, Suarez E, et al. Tenofovir disoproxil fumarate (TDF) versus emtricitabine plus TDF for treatment of chronic Hepatitis B (CHB) in

- subjects with persistent viral replication receiving adefovir dipivoxil (ADV). *Journal of Hepatology*. 2008; 48(Suppl.2): S34 (abstract 76).
- Bonino F, Marcellin P, Lau GK, Hadziyannis S, Jin R, Piratvisuth T, et al. Peginterferon Alfa-2a HBeAg-Negative Chronic Hepatitis B Study Group. Predicting response to peginterferon alpha-2a, lamivudine and the two combined for HBeAg-negative chronic hepatitis B. *Gut*. 2007; 56(5): 699-705. ([Abstract](#))
- Brunelle MN, Jacquard AC, Pichoud C, Durantel D, Carrouée-Durantel S, Villeneuve JP, et al. Susceptibility to antivirals of a human HBV strain with mutations conferring resistance to both lamivudine and adefovir. *Hepatology*. 2005; 41(6): 1391-8. ([Abstract](#))
- Chang T, Gish R, De Man R. A comparison of entecavir and lamivudine for HBeAg-positive chronic hepatitis B. *N Engl J Med* 2006; 354: 1001-1010. ([Abstract](#))
- Chloe WH, Hong SP, Kim BK, Ko SY, Jung YK, Kim JH, et al. Evolution of hepatitis B virus mutation during entecavir rescue therapy in patients with antiviral resistance to lamivudine and adefovir. *Antivir Ther* 2009;14(7): 985-93. ([Abstract](#))
- Colonna RJ, Rose R, Baldick CJ, Levine S, Pokornowski K, Yu CF, et al. Entecavir resistance is rare in nucleoside naive patients with hepatitis B. *Hepatology*. 2006;44(6):1656-65. ([Abstract](#))
- Cornberg M, Protzer U, Dollinger MM, Petersen J, Wedemeyer H, Berg T, et al. Prophylaxis, Diagnosis and Therapy of Hepatitis-B-Virus-(HBV-) Infection: upgrade of the guideline. *Z Gastroenterol*. 2007; 45(6): 525-74.
- Delaugerre C, Marcellin AG, Thibault V, Peytavin G, Bombled T, Bochet MV, et al. Human immunodeficiency virus (HIV) Type 1 reverse transcriptase resistance mutations in hepatitis B virus (HBV)-HIV-coinfected patients treated for HBV chronic infection once daily with 10 milligrams of adefovir dipivoxil combined with lamivudine. *Antimicrob Agents Chemother*. 2002;46(5):1586-8. ([Abstract](#))
- Di Marco V, Marzano A, Lampertico P, Andreone P, Santantonio T, Almasio PL, et al. Italian Association for the Study of the Liver (AISF) Lamivudine Study Group, Italy. Clinical outcome of HBeAg-negative chronic hepatitis B in relation to virological response to lamivudine. *Hepatology*. 2004; 40(4):883-91. ([Abstract](#))
- Erhardt A, Blondin D, Hauck K, Sagir A, Kohnle T, Heintges T, Haussinger D. Response to interferon alfa is hepatitis B virus genotype dependent: genotype A is more sensitive to interferon than genotype D. *Gut*. 2005; 54(7):1009-13. ([Abstract](#))
- Erhardt A, Göbel T, Ludwig A, et al. Response to antiviral treatment in patients infected with hepatitis B virus genotypes E-H. *J Med Virol*. 2009;1716-20 ([Abstract](#))
- Flink HJ, van Zonneveld M, Hansen BE, de Man RA, Schalm SW, Janssen HL. HBV 99-01 Study Group. Treatment with Peg-interferon alpha-2b for HBeAg-positive chronic hepatitis B: HBsAg loss is associated with HBV genotype. *Am J Gastroenterol*. 2006;101(2):297-303. ([Abstract](#))
- Fung SK, Andreone P, Han SH, et al. Adefovir-resistant hepatitis B can be associated with viral rebound and hepatic decompensation. *J Hepatol* 2005; 43(6):937-43. ([Abstract](#))
- Ge D, Fellay J, Thompson AJ, et al. Genetic variation in IL28B predicts hepatitis C treatment-induced viral clearance. *Nature*. 2009; 461(7262):399-401. ([Abstract](#))
- Hadziyannis SJ, Tassopoulos NC, Heathcote EJ, et al. Adefovir Dipivoxil 438 Study Group. Long-term therapy with adefovir dipivoxil for HBeAg-negative chronic hepatitis B for up to 5 years. *Gastroenterology*. 2006;131(6):1743-51.
- Heathcote EJ, Marcellin P, Buti M, et al. Three-year efficacy and safety of tenofovir disoproxil fumarate treatment for chronic hepatitis B. *Gastroenterology*. 2011;140(1):132-43
- Kamatani Y, Wattanapokayakit S, Ochi H, et al. A genome-wide association study identifies variants in the HLA-DP locus associated with chronic hepatitis B in Asians. *Nat Genet*. 2009; 41(5): 591-5.
- Kamili S, Sozzi V, Thompson G, et al. Efficacy of hepatitis B vaccine against antiviral drug-resistant hepatitis B virus mutants in the chimpanzee model. *Hepatology*. 2009; 49(5):1483-91. ([Abstract](#))
- Kurashige N, Ohkawa K, Hiramatsu N, et al. Two types of drug-resistant hepatitis B viral strains emerging alternately and their susceptibility to combination therapy with entecavir and adefovir. *Antivir Ther*. 2009;14(6):873-7. ([Abstract](#))
- Lada O, Gervais A, Branger M, et al. Long-term outcome of primary non-responders to tenofovir therapy in HIV/HBV-co-infected patients: impact of HBV genotype G. *Liver Int*. 2012;32(1):93-101. ([Abstract](#))

- Lai CL, Leung N, Teo EK, et al. A 1-year trial of telbivudine, lamivudine, and the combination in patients with hepatitis B e antigen-positive chronic hepatitis B. *Gastroenterology*. 2005; 129(2):528-36. (Abstract)
- Lai C, Shouval D, Lok A, et al. Entecavir versus lamivudine for patients with HBeAg-negative chronic hepatitis B. *N Engl J Med* 2006; 354:1011-20. (Abstract)
- Lampertico P, Viganò M, Manenti E, et al. Adefovir rapidly suppresses hepatitis B in HBeAg-negative patients developing genotypic resistance to lamivudine. *Hepatology* 2005; 42:1414-1419. (Abstract)
- Lampertico P, Viganò M, Manenti E, Iavarone M, Sablon E, Colombo M. Low resistance to adefovir combined with Lamivudine: a 3-year study of 145 Lamivudine-resistant hepatitis B patients. *Gastroenterology* 2007; 133(5):1445-51. (Abstract)
- Lampertico P, Viganò M, Facchetti F, Suter F, Minola E, Fracesetti O, et al. Entecavir monotherapy in 418 NUC-naïve patients with chronic hepatitis B from filed practice: High efficacy and favourable safety profile over 3 years of treatment. *Hepatology* 2011; 54(4):1043A
- Lau GK, Piratvisuth T, Luo KX, et al. Peginterferon Alfa-2a HBeAg-Positive Chronic Hepatitis B Study Group. Peginterferon Alfa-2a, lamivudine, and the combination for HBeAg-positive chronic hepatitis B. *N Engl J Med*. 2005; 30;352(26):2682-95. (Abstract)
- Liaw YF, Gane E, Leung N, et al. 2-Year GLOBE trial results: telbivudine is superior to lamivudine in patients with chronic hepatitis B. *Gastroenterology*. 2009;136(2):486-95. (Abstract)
- Lee YS, Suh DJ, Lim YS, et al. Increased risk of adefovir resistance in patients with lamivudine-resistant chronic hepatitis B after 48 weeks of adefovir dipivoxil monotherapy. *Hepatology*. 2006; 43(6):1385-91. (Abstract)
- Liaw YF, Sung JJ, Chow WC, et al. Cirrhosis Asian Lamivudine Multicentre Study Group. Lamivudine for patients with chronic hepatitis B and advanced liver disease. *N Engl J Med* 2004; 351(15):1521-31. (Abstract)
- Liaw YF, Gane E, Leung N, Zeuzem S, et al. GLOBE Study Group. 2-Year GLOBE trial results: telbivudine is superior to lamivudine in patients with chronic hepatitis B. *Gastroenterology*. 2009;136(2):486-95. (Abstract)
- Lim SG, Ng TM, Kung N, et al. Emtricitabine FTCB-301 Study Group. A double-blind placebo-controlled study of emtricitabine in chronic hepatitis B. *Arch Intern Med*. 2006; 166(1):49-56. (Abstract)
- Lin CL, Tsai SL, Lee TH, Chien RN, Liao SK, Liaw YF. High frequency of functional anti-YMDD and -mutant cytotoxic T lymphocytes after in vitro expansion correlates with successful response to lamivudine therapy for chronic hepatitis B. *Gut*. 2005; 54 (1): 152-61. (Abstract)
- Locarnini S, Hatzakis A, Heathcote J, et al. Management of antiviral resistance in patients with chronic hepatitis B. *Antivir Ther*. 2004; 9 (5): 679-93. (Abstract)
- Lok A, Trinh HN, Carosi G, et al. Entecavir monotherapy for 96 weeks is comparable to combination therapy with entecavir plus tenofovir in nucleos(t)ide-naïve patients with chronic hepatitis B: The be-low study. *Hepatology* 2011; 54(4):417A
- Manns M, Jeffers L, Dalekos G, Berg T, Trepo C, et al. Safety and efficacy of 96 weeks of tenofovir disoproxil fumarate therapy in lamivudine experienced patients. *J Hepatol* 2009; 50(1) : S335.
- Marcellin P, Chang TT, Lim SG, et al. Adefovir Dipivoxil 437 Study Group. Adefovir dipivoxil for the treatment of hepatitis B e antigen-positive chronic hepatitis B. *N Engl J Med*.2003; 27;348(9):808-16.
- Marcellin P, Lau GK, Bonino F, et al Peginterferon alfa-2a alone, lamivudine alone, and the two in combination in patients with HBeAg-negative chronic hepatitis B. *N Engl J Med*. 2004; 351(12):1206-17. (Abstract)
- Marcellin P, Heathcote EJ, Buti M, et al. Tenofovir disoproxil fumarate versus adefovir dipivoxil for chronic hepatitis B. *N Engl J Med*. 2008; 359(23):2442-55. (Abstract)
- Marcellin P, Piratvisuth T, Brunetto MR, et al. A finite course of peginterferon alfa-2a results in inactive chronic hepatitis B and HBsAg clearance 5 years Post treatment in patients with HBeAg-negative disease: baseline characteristics and predictive factors of long-term response. *Hepatology* 2009; 50 (4): 487A.
- Matthews GV, Bartholomeusz A, Locarnini S, et al. Characteristics of drug resistant HBV in an international collaborative study of HIV-HBV-infected individuals on extended lamivudine therapy. *AIDS* 2006;20(6):863-70. (Abstract)

- McMahon MA, Jilek BL, Brennan TP, et al. The HBV drug entecavir - effects on HIV-1 replication and resistance. *N Engl J Med* 2007;356:2614-21. ([Abstract](#))
- Milazzo L, Caramma I, Lai A, et al. Telbivudine in the treatment of chronic hepatitis B: experience in HIV type-1-infected patients naive for antiretroviral therapy. *Antivir Ther* 2009; 14(6):869-72. ([Abstract](#))
- Nguyen MH, Huy NT, Nguyen T, et al. Complete viral suppression and ALT normalization on entecavir (ETV) therapy in patients who were previously treated with adefovir (ADV): A multicenter study. *Hepatology* 2009; 50,4: 540A.
- Niederau C, Heintges T, Lange S, et al. Long-term follow-up of HBeAg-positive patients treated with interferon alfa for chronic hepatitis B. *N Engl J Med* 1996;30;334(22):1422-7. ([Abstract](#))
- Nelson M, Ports-mouth S, Stebbing J. An open-label study of tenofovir in HIV-1 and hepatitis B virus co-infected individuals. *AIDS* 2003;17:F7-F10. ([Abstract](#))
- Núñez M, Pérez-Olmeda M, Díaz B, Ríos P, González-Lahoz J, Soriano V. Activity of tenofovir on hepatitis B virus replication in HIV-co-infected patients failing or partially responding to lamivudine. *AIDS* 2002;16:2352-54. ([Abstract](#))
- Petersen J, Ratziu V, Buti M, et al. Entecavir plus tenofovir combination as rescue therapy in pre-treated chronic hepatitis B patients: An international multicenter cohort study. *J Hepatol.* 2011 Oct 26. [Epub ahead of print]. ([Abstract](#))
- Petersen J, Buggisch P, Stoehr A, et al. Stopping long-termnucleosid(t)ide analogue therapy before HbsAg loss or seroconversion in HbeAg negative chronic hepatitis B patients: Experience from five referral centers in Germany. *Hepatolog* 2011 54(4):1033A.
- Ratcliffe L, Beadsworth MB, Pennell A, Phillips M, Vilar FJ. Managing hepatitis B/HIV co-infected: adding entecavir to truvada (tenofovir disoproxil/emtricitabine) experienced patients. *AIDS.* 2011 ;25(8):1051-6. ([Abstract](#))
- Reijnders JG, Deterding K, Petersen, et al. Antiviral effect of entecavir in chronic hepatitis B: influence of prior exposure to nucleos(t)ide analogues. *J Hepatol.* 2010;52(4):493-500. ([Abstract](#))
- Reijnders JG, Perquin MJ, Zhang N, Hansen BE, Janssen HL. Nucleos(t)ide analogues only induce temporary hepatitis B e antigen seroconversion in most patients with chronic hepatitis B. *Gastroenterology.* 2010;139(2):491-8. ([Abstract](#))
- Schmutz G, Nelson M, Lutz T, et al. Combination of tenofovir and lamivudine versus tenofovir after lamivudine failure for therapy of hepatitis B in HIV-coinfection. *AIDS.* 2006;20(15):1951-4.
- Sheldon JA, Corral A, Rodés B, et al. Risk of selecting K65R in antiretroviral-naive HIV-infected individuals with chronic hepatitis B treated with adefovir. *AIDS* 2005;19(17):2036-8. ([Abstract](#))
- Sheldon J, Ramos B, Garcia-Samaniego J, et al. Selection of Hepatitis B Virus (HBV) Vaccine Escape Mutants in HBV-Infected and HBV/HIV-Coinfected Patients Failing Antiretroviral Drugs With Anti-HBV Activity. *J Acquir Immune Defic Syndr.* 2007; 46(3):279-82. ([Abstract](#))
- Shim JH, Suh DJ, Kim KM, et al. Efficacy of entecavir in patients with chronic hepatitis B resistant to both lamivudine and adefovir or to lamivudine alone. *Hepatology.* 2009; 50(4):1064-71. ([Abstract](#))
- Snow-Lampart A, Chappell B, Curtis M, et al. No resistance to tenofovir disoproxil fumarate detected after up to 144 weeks of therapy in patients monoinfected with chronic hepatitis B virus. *Hepatology.* 2011;53(3):763-73.
- Sung JJ, Lai JY, Zeuzem S, et al. Lamivudine compared with lamivudine and adefovir dipivoxil for the treatment of HBeAg-positive chronic hepatitis B. *J Hepatol.* 2008;48(5):728-35. ([Abstract](#))
- Tenney DJ, Rose RE, Baldick CJ, et al. Two-year assessment of entecavir resistance in Lamivudine-refractory hepatitis B virus patients reveals different clinical outcomes depending on the resistance substitutions present. *Antimicrob Agents Chemother.* 2007;51(3):902-11. ([Abstract](#))
- Van Bommel F, Wunsche T, Mauss S, et al. Comparison of adefovir and tenofovir in the treatment of lamivudine-resistant hepatitis B virus infection. *Hepatology* 2004; 40: 1421-25. ([Abstract](#))
- Van Bömmel F, de Man RA, Wedemeyer H, et al. Long-term efficacy of tenofovir monotherapy for hepatitis B virus-monoinfected patients after failure of nucleoside/nucleotide analogues. *Hepatology.* 2010; 51(1): 73-80. ([Abstract](#))

- Westland C, Delaney W, Yang H, et al. Hepatitis B virus genotypes and virologic response in 694 patients in phase III studies of adefovir dipivoxil. *Gastroenterology* 2003;125(1):107-16. ([Abstract](#))
- Yuen MF, Seto WK, Fung J, Wong DK, Yuen JC, Lai CL. Three years of continuous entecavir therapy in treatment-naïve chronic hepatitis B patients: VIRAL suppression, viral resistance, and clinical safety. *Am J Gastroenterol*. 2011;106(7):1264-71. ([Abstract](#))
- Zeuzem S, Gane E, Liaw YF, Lim SG, DiBisceglie A, Buti M, et al. Baseline characteristics and early on-treatment response predict the outcomes of 2 years of telbivudine treatment of chronic hepatitis B. *J Hepatol*. 2009; 51(1):11-20. ([Abstract](#))

# 11. Hepatitis D – Diagnosis and Treatment

*Heiner Wedemeyer*

## Introduction

Hepatitis delta is considered the most severe form of viral hepatitis in humans. The hepatitis delta virus (HDV) is a defective RNA virus which requires the hepatitis B virus (HBV) surface antigen (HBsAg) for complete replication and transmission, while the full extent of the HBV helper function is unexplored (Rizzetto 1983, Taylor 2006). Hence, hepatitis delta occurs only in HBsAg-positive individuals either as acute coinfection or as superinfection in patients with chronic hepatitis B (Wedemeyer 2010) (Figure 1). Several studies have shown that chronic HDV infection leads to more severe liver disease than chronic HBV mono-infection with an accelerated course of fibrosis progression, possibly a slightly increased risk of hepatocellular carcinoma and early decompensation in the setting of established cirrhosis (Hughes 2011, Fattovich 2000, Fattovich 1987). Simultaneous HBV and HDV infection has also been shown to be more severe than infection with HBV alone in chimpanzees (Dienes 1990). An easy to apply clinical score has been suggested to predict the likelihood of experiencing a clinical event for patients with hepatitis delta, the baseline-event-anticipation (BEA) score (Calle Serrano 2011). So far, only (pegylated) interferon  $\alpha$  treatment has been shown to exert some antiviral activity against HDV and has been linked to improve the long-term outcome. Data on the use of pegylated interferon confirm earlier findings, PEG-IFN leads to sustained virological response rates in about one quarter of patients. Alternative treatment options including HBV entry inhibitors and prenylation inhibitors are currently in clinical development.

### Simultaneous coinfection



### HDV Super Infection

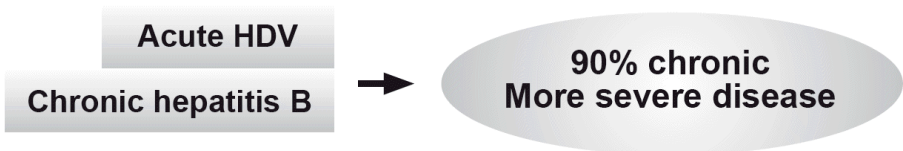


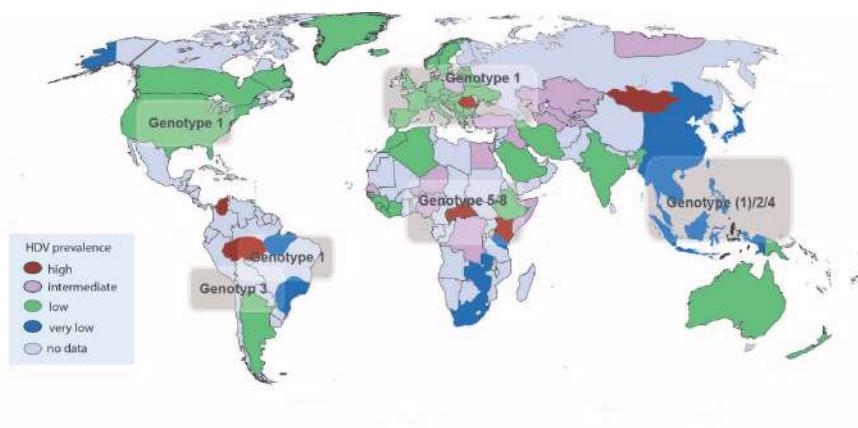
Figure 1. Courses of hepatitis delta.

## Virology of hepatitis delta

The HDV virion is approximately 36 nm large, containing HDV RNA and delta antigen. HDV RNA is single-stranded, highly base-paired, circular and by far the smallest known genome of any animal virus, containing close to 1700 nucleotides (Taylor 2006). It is coated with the envelope protein derived from the pre-S and S antigens of the hepatitis B virus. The HDV RNA has six open reading frames (ORFs), three on the genomic and three on the antigenomic strand. One ORF codes for the hepatitis delta antigen (HDAg), while the other ORFs do not appear to be actively transcribed. Two HDAgs exist: the small HDAg (24 kD) is 155 amino acids long and the large HDAg (27 kD) is 214 amino acids long. A single nucleotide change (A-G) in the small HDAg sequence leads to the synthesis of the large HDAg. The small HDAg accelerates genome synthesis, while the large HDAg that inhibits HDV RNA synthesis is necessary for virion morphogenesis (Taylor 2006). Replication of HDV RNA occurs through a 'double rolling circle model' in which the genomic strand is replicated by a host RNA polymerase to yield a multimeric linear structure that is then autocatalytically cleaved to linear monomers and ligated into the circular HDV RNA viral progeny.

Genetic analysis has revealed the presence of at least eight HDV genotypes (Hughes 2011) (Figure 2). Genotype 1 is the most frequently seen genotype and is distributed throughout the world, especially in Europe, the Middle East, North America and North Africa. Genotype 2 is seen in East Asia and the Yakutia region of Russia, and genotype 3 is seen exclusively in the northern part of South America, especially in the Amazon Basin. Genotype 4 is seen in Taiwan and Japan and genotypes 5-8 in African countries. Genotype 1 is associated with both severe and mild disease whereas genotype 2 causes a milder disease over a long-term course (Su 2006). All patients who have been included in the large European HIDE-I

treatment trial in Germany, Turkey and Greece were infected with HDV genotype I (Zachou 2010).

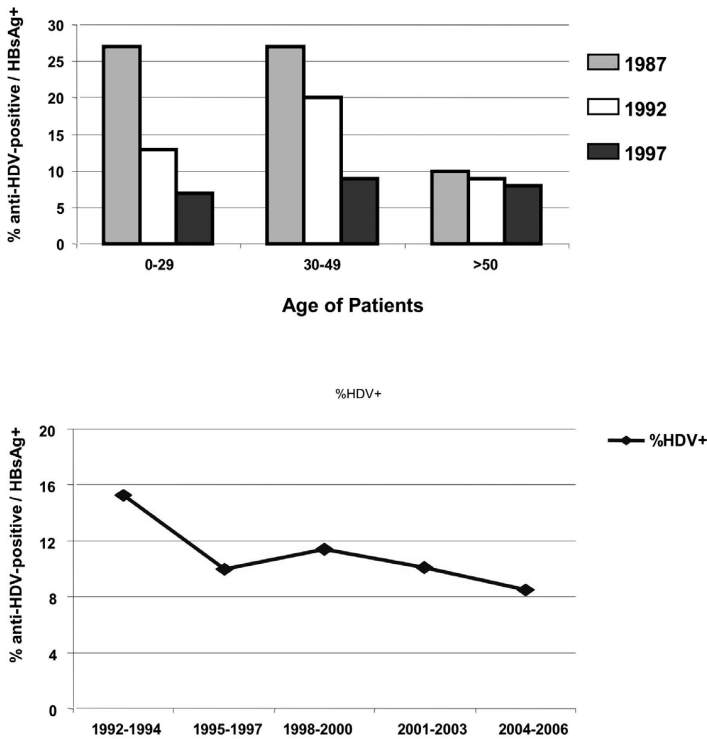


**Figure 2. Prevalence of HDV genotypes.**

## Epidemiology of hepatitis delta

Hepatitis delta is not an uncommon disease. Being linked to HBV, HDV is spread in the same way as HBV, mainly through parenteral exposure (Niro 1999). It is highly endemic in Mediterranean countries, the Middle East, Central Africa, and northern parts of South America (Hughes 2011) (Figure 2). In Western countries, high anti-HDV prevalence is found in HBsAg-positive intravenous drug users both in Europe (Wedemeyer 2007, Gaeta 2000) and North America (Kurcirka 2010). Worldwide, more than 350 million people are chronically infected with HBV and 15-20 million of those are estimated to be anti-HDV positive (Wedemeyer 2010). Delta hepatitis was endemic in Southern Europe. Several studies performed in the 1980s and 1990s showed a prevalence of anti-HDV among HBsAg-positive individuals of more than 20%. As a result of the implementation of HBV vaccination programs, the incidence of HDV infections significantly decreased in Southern Europe in the 1990s (Gaeta 2000) (Figure 3). In Turkey, HDV prevalence in HBsAg-positive patients range from <5% in western Turkey to >27% in southeast Turkey (Degertekin 2008). Other countries with a particularly high prevalence of hepatitis delta are Mongolia with up to one third of chronic hepatitis cases being caused by HDV infection (Tsatsralt-Od 2005), some Central Asian republics, northwestern states of Brazil, and some Polynesian islands (Hughes 2011). Of note, prevalence rates of HBV and HDV are not linked - for example, HDV infections are rather rare in most parts of mainland China despite very high frequencies of hepatitis B.





**Figure 3. Prevalence of hepatitis D virus in Italy and Germany.**

- a) Chronic Hepatitis D: a vanishing disease. From Gaeta GB, Hepatology 2000.
- b) Hepatitis D virus infection - Not a vanishing disease in Europe! From Wedemeyer, Hepatology 2007.

Chronic delta hepatitis still represents a significant health burden in Central Europe – in particular due to immigration from highly endemic areas (Wedemeyer 2007, Erhardt 2003) (Figure 4, Table 1). In our experience at a referral center for liver disease, about 8-10% of HBsAg-positive patients still test positive for anti-HDV (Figure 3). More than three quarters of our delta hepatitis patients were not born in Germany. However, the geographical origin of our patients has changed during the last decade. While until the mid-1990s the majority of HDV-positive patients were born in Turkey, the proportion of Eastern European patients has significantly increased in recent years (Wedemeyer 2007) (Table 1). Similarly, high HDV prevalence in immigrant populations has been described in clinics in the UK (Cross 2008), France and Italy (Le Gal 2007, Mele 2007). HDV can also be found in high frequencies in HBsAg-positive HIV-infected individuals with about 14.6% in different European regions (Soriano 2011).

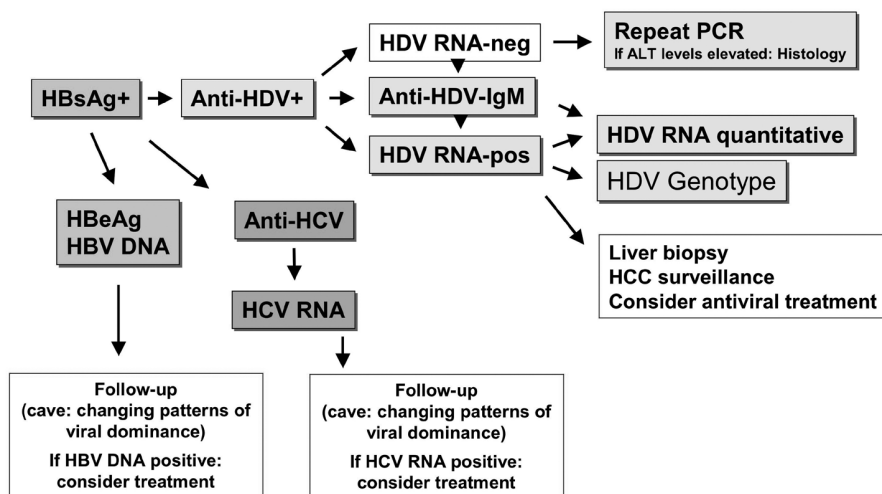


Figure 4. Diagnostic steps in delta hepatitis.

Table 1. Hepatitis D virus (HDV) detection in Germany between 1992–1996 vs 1997–2006 compared to the country of birth of patients.

Origin of patients	HDV diagnosis* 1992–1996 n=45	HDV diagnosis* 1997–2006 n=100	p-value
Germany	20.9 (n=9)	19.2 (n=19)	n.s.
Turkey	42.0 (n=18)	20.2 (n=20)	0.009
Eastern Europe/NIS	14.0 (n=6)	37.3 (n=37)	0.005

\* in %. From Heidrich, Journal of Viral Hepatitis, 2009; n.s., not significant; NIS, Newly Independent States (ex-USSR)

## Pathogenesis of HDV infection

Knowledge about the pathogenesis of delta hepatitis infection is limited. Clinical observations have provided examples of mostly an immune-mediated process in delta hepatitis disease. However, patterns suggesting a cytopathic viral disease have occasionally been observed. A typical example of the latter were outbreaks of severe hepatitis in the northern part of South America (Nakano 2001). These mostly fulminant hepatitis cases were induced by genotype 3 delta virus. However, in the usual case of delta hepatitis the liver histology is not different from a patient with hepatitis B or hepatitis C with accompanying necroinflammatory lesions. Importantly, HDV viremia is not directly associated with the stage of liver disease (Zachou 2010). Cellular immune responses against the hepatitis D virus have been described (Nisini 1997, Aslan 2003, Huang 2004, Grabowski 2011) suggesting that the quantity and quality of T cell responses may be associated with some control of the infection. Some data from our group indicate that the frequency of cytotoxic CD4<sup>+</sup> T cells is higher in delta hepatitis patients than in individuals with HBV or

HCV infection (Aslan 2006) and that HDV-specific IFN gamma and IL-2 responses are more frequent in patients with low HDV viremia (Grabowski 2011). This still limited information suggests that HDV is mainly an immune-mediated disease, at least in HDV genotype 1 infection. Ideally, antiviral therapies should therefore also aim to enhance anti-HDV immunity to confer long-term control of the infection. Still, sterilizing immunity against HDV has not been demonstrated yet. Of note, chimpanzees that have recovered from HDV infection were successfully reinfected with HDV in one study performed in the 1980s (Negro 1988). Coinfections with multiple hepatitis viruses are associated with diverse patterns of reciprocal inhibition of viral replication (Raimondo 2006, Wedemeyer 2010). HDV has frequently been shown to suppress HBV replication (Jardi 2001, Sagnelli 2000). Between 70% and 90% of delta hepatitis patients are HBeAg-negative with low levels of HBV DNA. Humanized HBsAg-positive mice that become superinfected HDV also show a decrease in HBV replication (Lutgehetmann 2011). A molecular explanation for the suppression of HBV replication by HDV has been suggested as HDV proteins p24 and p27 may repress HBV enhancers (Williams 2009). However, viral dominance may change over time (Wedemeyer 2010) and about half of the hepatitis delta patients showed significant HBV replication in one study (Schaper 2010).

There is increasing evidence that HDV not only suppresses HBV replication but also HCV replication in triple-infected patients. In our experience, less than one fifth of anti-HCV/HBsAg/anti-HDV-positive individuals are positive for HCV RNA (Heidrich 2009). We even observed a case where acute HDV/HBV superinfection led to clearance of chronic hepatitis C infection (Deterding 2009). It is not clear how many anti-HCV-positive/HCV RNA-negative patients recover from HCV infection and how many patients just show a suppressed HCV replication in the context of viral coinfections.

## **Clinical course of delta hepatitis**

### **Acute HBV/HDV coinfection**

Acute HBV/HDV coinfection leads to recovery in more than 90% of cases but frequently causes severe acute hepatitis with a high risk for developing a fulminant course (Rizzetto 2009). In contrast, HDV is cleared spontaneously only in a minority of patients with HDV superinfection of chronic HBsAg carriers (Figure 1). The observation that histopathology of simultaneous HBV and HDV infection is more severe than in infection with HBV alone has also been documented in experiments with chimpanzees (Dienes 1990). Several outbreaks of very severe courses of acute delta hepatitis in patients have been described in different regions of the world (Casey 1996, Flodgren 2000, Tsatsalt-Od 2006). Fortunately, acute delta hepatitis has become rather infrequent over the last two decades in Western countries due to the introduction of vaccination programs.

### **Chronic delta hepatitis**

Several studies have shown that chronic HDV infection leads to more severe liver disease than chronic HBV mono-infection, with an accelerated course of fibrosis progression, and early decompensation in the presence of cirrhosis (Fattovich 1987, Jardi 2001, Sagnelli 2000, Rizzetto 2000, Uzunalimoglu 2001). HDV accounts for

almost half of all cases of liver cirrhosis and hepatocellular carcinoma in southeast Turkey (Degertekin 2008, Uzunalimoglu 2001, Yurdaydin 2006a). An observational study from Taiwan has reported a cumulative survival of HDV genotype 1-infected patients of as low as 50% after 15 years (Su 2006). Long-term follow-up data from Italy confirm the particularly severe course of hepatitis delta (Romeo 2009; Niro 2010). HDV infection has also been associated with a higher risk of developing liver cirrhosis in HIV-coinfected patients as 66% of HIV/HBV/HCV/HDV-infected patients but only 6% of HBV/HCV/HIV-infected patients present with liver cirrhosis in a Spanish cohort (Castellares 2008). Similarly, delta hepatitis was associated with poorer survival in HIV-infected patients in Taiwan (Sheng 2007).

An easy to apply clinical score, the baseline-event anticipation (BEA) score, has been suggested to predict the risk of developing liver-related morbidity and mortality (Calle Serrano 2011). Factors associated with a poor long-term outcome included age above 40, male sex, low platelet counts, high bilirubin and INR values and southeast Mediterranean origin.

## Diagnosis of delta hepatitis

We recommend that every HBsAg-positive patient be tested for anti-HDV antibodies at least once. There is currently no evidence that direct testing for HDV RNA in the absence of anti-HDV is of any use. A positive result for anti-HDV does not necessarily indicate “active” delta hepatitis, as HDV RNA can become negative indicating recovery from HDV infection. Over the long term as well, anti-HDV antibodies can be lost after recovery. However, anti-HDV may persist for years even when the patient has experienced HBsAg seroconversion (Wedemeyer 2007).

“Active” replicative delta hepatitis should be confirmed by the detection of HDV RNA. If HDV RNA is positive, subsequent evaluation of grading and staging of liver disease, surveillance for hepatocellular carcinoma and consideration of antiviral treatment is indicated. HDV RNA quantification is offered by some laboratories. However, so far there is no evidence that HDV RNA levels correlate with any clinical marker of liver disease (Zachou 2010). HDV RNA quantification is useful in particular if antiviral treatment is indicated. Stopping rules during antiviral treatment depending on the level of antiviral decline are currently being evaluated. Patients with less than a 3  $\log_{10}$  decline of HDV RNA after 24 weeks of treatment will not benefit from antiviral treatment with PEG-IFN  $\alpha$ -2b (Erhardt 2006). There is currently no WHO standard for HDV. Various PCR assays have been presented recently, however, the performance of these assays may differ significantly and detection rates for rare HDV genotypes may be low (Mederacke 2010, Niro 2011).

HDV genotyping is performed by some research labs and may help to identify patients with a higher or lower risk of developing end-stage liver disease (Su 2006). In Western countries almost all patients are infected with HDV-genotype 1, thus genotyping may be considered only in immigrants or populations with mixed genotype prevalence.

In the 1980s and 1990s the diagnosis of active delta hepatitis was dependent on anti-HDV IgM testing. Anti-HDV IgM testing might still be useful in patients who test HDV RNA negative but have evidence of liver disease, which cannot be explained by other reasons. Due to the variability of the HDV genome and the lack

of standardization of HDV RNA assays, HDV RNA may test false negative or be under the detection limit of the assay in the case of fluctuating viral load. In these cases, HDV RNA testing should be repeated and anti-HDV IgM testing might be performed, if available. Anti-HDV IgM levels also correlate with disease activity and may be predictive for response to IFN  $\alpha$ -based antiviral therapy (Mederacke 2012, in press).

As delta hepatitis only occurs in the context of HBV coinfection, a solid work-up of HBV infection including HBV DNA quantification and HBeAg/anti-HBe determination is warranted. Most hepatitis delta patients in Europe are infected with HBV genotype D but infection with genotype A can also occur (Soriano 2011) which may have significant implications for treatment decisions as HBV genotype A shows a better responses to interferon  $\alpha$  therapy (Janssen 2005). Similarly, testing for anti-HCV and anti-HIV is mandatory. In our experience, up to one third of anti-HDV-positive patients also test positive for anti-HCV (Heidrich 2009).

## Treatment of delta hepatitis

### Nucleoside and nucleotide analogs

Several nucleoside and nucleotide analogs used for the treatment of HBV infection have been shown to be ineffective against HDV (Table 2). Famciclovir, used in the 1990s to treat HBV infection (Wedemeyer 1999), had no significant antiviral activity against HDV in a Turkish trial (Yurdaydin 2002). Similarly, lamivudine was ineffective in trials of delta hepatitis (Wolters 2000, Niro 2005a, Yurdaydin 2008, Lau 1999b). Ribavirin alone or in combination with interferon also did not lead to increased rates of HDV RNA clearance (Niro 2005a, Gunsar 2005, Garripoli 1994). However, a long-term observational study of HIV-infected individuals receiving HAART followed HBV/HDV/HIV-coinfected individuals for a median of more than 6 years; over this time, a decline of HDV RNA from 7 log<sub>10</sub> to 5.8 log<sub>10</sub> was observed and 3 out of 16 patients became HDV RNA-negative (Sheldon 2008). Thus, very long treatment with HBV polymerase inhibitors may lead to beneficial effects in delta hepatitis possibly due to a reduction of HBsAg levels. Future long-term trials will need to confirm these data in triple-infected individuals.

**Table 2. Treatment options in delta hepatitis.**

<b>Nucleos(t)ide Analogs</b>	
Famciclovir ineffective	Yurdaydin 2002
Lamivudine ineffective	Wolters 2000, Lau 1999, Niro 2005a, Niro 2008, Yurdaydin 2008
Ribavirin ineffective	Niro 2006, Garripoli 1994, Gunsar 2005
<b>Interferon <math>\alpha</math></b>	
Sustained biochemical responses in 0-36% of patients	Farci 1994, Di Marco 1996, Niro 2005b,
Few studies with virological endpoints	Yurdaydin 2008
Treatment >12 months may be required	
Higher IFN doses were associated with better survival in small study cohort	Farci 2004

Another promising and surprising alternative to the currently approved HBV polymerase inhibitors may be clevudine. Clevudine, a nucleoside analog currently

in development for the treatment of hepatitis B, has recently been shown to inhibit delta virus viremia in woodchucks (Casey 2005). However, a first pilot trial showed no significant HDV RNA declines (Yakut 2010).

## Recombinant interferon $\alpha$

Interferon  $\alpha$  has been used for the treatment of delta hepatitis since the mid 1980s (Rizzetto 1986). Since then, many trials have explored different durations and doses of interferon  $\alpha$  in HDV-infected patients. However, data are difficult to compare as endpoints are different in the trials and few studies have followed HDV RNA levels over time (Niro 2005b).

One randomized Italian study on the use of high dose interferon  $\alpha$  associated a beneficial long-term outcome in delta hepatitis patients with high dose interferon treatment (Farci 1994, Farci 2004). Some studies have used extended doses of interferon treatment and it seems that two years of treatment is superior in terms of HDV RNA clearance (Niro 2005b). In one NIH case report, 12 years of interferon treatment led finally to resolution of both HDV infection and HBsAg clearance (Lau 1999a). High doses of interferon and extended treatment are tolerated by only a minority of patients and treatment options are very limited for the majority (Manns 2006).

## Pegylated interferon $\alpha$

Pegylated interferon has been used in small trials to treat delta hepatitis, with sustained virological response rates of about 20% (Castelnaud 2006, Niro 2006, Erhardt 2006) (Table 3).

**Table 3. Pegylated interferon in delta hepatitis.**

Study		Outcome
Castelnaud, Hepatology 2006	12 months of PEG-IFN $\alpha$ -2b (n=14)	SVR in 6 patients (43%)
Niro, Hepatology 2006	72 weeks of PEG-IFN $\alpha$ -2b (n=38) – Monotherapy: n=16 – PEG-IFN + ribavirin during first 48 weeks: n=22	SVR in 8 patients (21%) Ribavirin had no additional effect
Erhardt, Liver Int 2006	48 weeks of PEG-IFN $\alpha$ -2b (n=12)	SVR in 2 patients (17%)
Wedemeyer, NEJM 2011	a) 48 weeks PEG-IFN $\alpha$ -2a + adefovir (n=31) or b) PEG-IFN $\alpha$ -2a + placebo (n=29) or c) Adefovir (n=30)	HDV RNA-negative Group a) 23% Group b) 24% Group c) 0%

Results of the Hep-Net International Delta hepatitis Intervention Trial (HIDIT-1) were published in 2011 (Wedemeyer 2011). 90 patients (42 in Germany, 39 in Turkey and 9 in Greece) with chronic HDV infection and compensated liver disease were randomized to receive either 180  $\mu$ g PEG-IFN  $\alpha$ -2a QW plus 10 mg adefovir dipivoxil QD (group A, N=31), 180  $\mu$ g PEG-IFN  $\alpha$ -2a QW plus placebo (group B, N = 29) or 10 mg adefovir dipivoxil qd alone (group C, N=30) for 48 weeks. HBV DNA and HDV RNA were investigated by real-time PCR. Ten patients did not complete 48 weeks of therapy because of disease progression (N=6) or interferon-

associated side effects (N=4). Both PEG-IFN groups showed a significantly higher reduction in mean HDV RNA levels than the adefovir monotherapy group by week 48. HDV RNA was negative 24 weeks after the end of treatment in 28% of patients receiving PEG-IFN but in none of patients treated with adefovir alone. While patients receiving PEG-IFN  $\alpha$ -2a alone or adefovir monotherapy had similar mean HBsAg levels at week 0 and week 48, the PEG-IFN  $\alpha$ -2a/adevovir combination group showed a 1.1 log<sub>10</sub> IU/ml decline of HBsAg levels by week 48 (p <0.001) with 10/30 patients achieving a decline in HBsAg of more than 1 log (10) IU/ml. These data are in line with a report from Greece of a significant decline in HbsAg levels in delta hepatitis patients receiving long-term treatment with interferon  $\alpha$  (Manesis 2007).

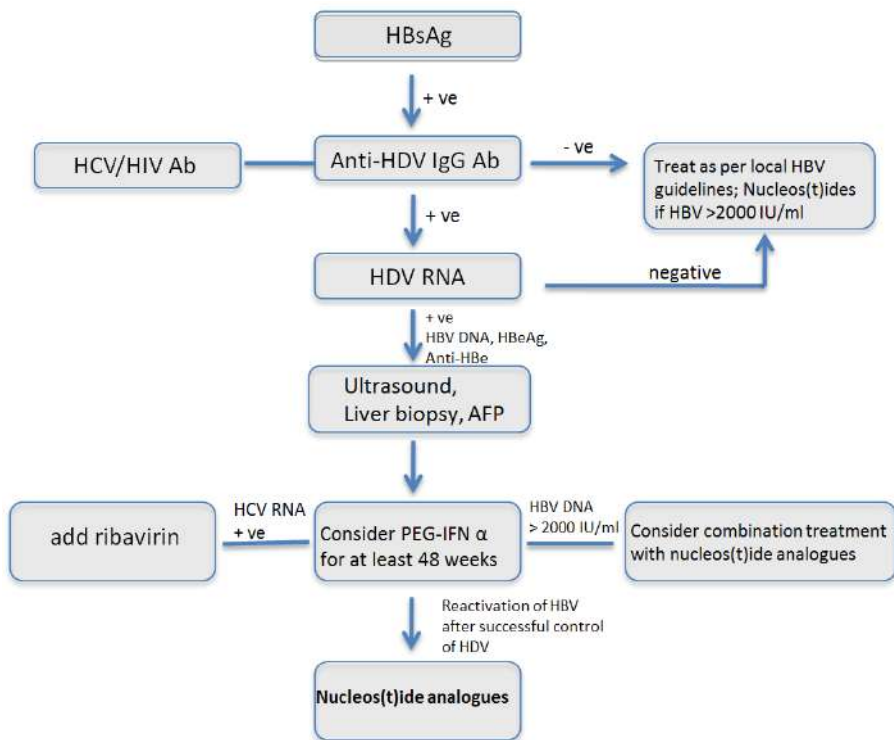
Overall the HIDIT-1 study showed that (i) PEG-IFN  $\alpha$ -2a displays a significant antiviral efficacy against HDV in more than 40% of patients with 24% becoming HDV RNA negative after 48 weeks; (ii) adefovir dipivoxil has little efficacy in terms of HDV RNA reduction but may be considered for patients with significant HBV replication; (iii) combination therapy of PEG-IFN  $\alpha$ -2a plus adefovir has no advantages for HBV DNA or HDV RNA reduction; (iv) a combination therapy of pegylated interferon with adefovir was superior to either monotherapy in reducing HBsAg levels in HBV-infected patients (Wedemeyer 2011). However, adefovir treatment was associated with a decline in glomerular filtration rates (Mederacke 2012, in press) and thus PEG-IFN  $\alpha$ /adevovir combination treatment cannot be recommended as the first-line treatment for all patients with hepatitis delta.

Currently, additional trials are ongoing to investigate the efficacy of PEG-IFN  $\alpha$ -2a in combination with tenofovir for the treatment of delta hepatitis. First data of the HIDIT-2 trial are expected in 2012. Moreover, alternative treatment options are currently being explored. Among these, prenylation inhibitors may be promising (Bordier 2003). HDV replication depends on a prenylation step and prenylation inhibitors have already been developed for the treatment of malignancies. The HBV entry inhibitor Myrcludex-B is also being developed for hepatitis delta. Myrcludex-B is a lipopeptide derived from the preS1 domain of the HBV envelope (Petersen 2008) and has been shown to hinder HDV infection in uPA/SCID mice transplanted with human hepatocytes (Lütgehetmann 2011).

## Liver transplantation for hepatitis delta

Liver transplantation remains the ultimate treatment option for many hepatitis delta patients with end-stage liver disease. Hepatitis delta patients have lower risk for reinfection after transplantation than HBV monoinfected patients (Samuel 1993). If prophylaxis by passive immunization with anti-HBs antibodies and administration of HBV polymerase is applied, HBV/HDV reinfection can be prevented in all individuals (Rosenau 2007) leading to an excellent long-term outcome after transplantation. HDV RNA levels rapidly decline during the first days after transplantation (Mederacke 2011) but HDAg may persist in the transplanted liver for several years (Smedile 1998, Mederacke 2011). Long-term prophylaxis to prevent HBV reinfection should be recommended in patients transplanted for hepatitis delta patients as reinfection may lead to HDV reactivation for which treatment options are very limited.

More information on hepatitis delta for physicians and patients can be found on the website of the Hepatitis Delta International Network: [www.hepatitis-delta.org](http://www.hepatitis-delta.org)



**Figure 5. Treatment algorithm for hepatitis delta.**

## References

- Aslan N, Yurdaydin C, Bozkaya H, Baglan P, Bozdayi AM, Tillmann HL, et al. Analysis and function of delta-hepatitis virus-specific cellular immune responses. *J Hepatol* 2003;38:15-6.
- Aslan N, Yurdaydin C, Wiegand J, Greten T, Ciner A, Meyer MF, et al. Cytotoxic CD4 T cells in viral hepatitis. *J Viral Hepat* 2006;13:505-14. (Abstract)
- Bordier BB, Ohkanda J, Liu P, Lee SY, Salazar FH, Marion PL, et al. In vivo antiviral efficacy of prenylation inhibitors against hepatitis delta virus. *J Clin Invest* 2003;112:407-14. (Abstract)
- Calle Serrano B, Heidrich B, Homs M, et al. Development and Evaluation of a Baseline Event-Anticipation (BEA)-Score for Hepatitis Delta. 62nd Annual Meeting of the American Association for the Study of Liver Disease (AASLD 2011). San Francisco, November 4-8. 2011. Abstract 171.
- Casey J, Cote PJ, Toshkov IA, Chu CK, Gerin JL, Hornbuckle WE, et al. Clevudine inhibits hepatitis delta virus viremia: a pilot study of chronically infected woodchucks. *Antimicrob Agents Chemother* 2005;49:4396-9. (Abstract)
- Casey JL, Niro GA, Engle RE, Vega A, Gomez H, McCarthy M, et al. Hepatitis B virus (HBV)/hepatitis D virus (HDV) coinfection in outbreaks of acute hepatitis in the Peruvian Amazon basin: the roles of HDV genotype III and HBV genotype F. *J Infect Dis* 1996;174:920-6. (Abstract)
- Castellares C, Barreiro P, Martin-Carbonero L, Labarga P, Vispo ME, Casado R, et al. Liver cirrhosis in HIV-infected patients: prevalence, aetiology and clinical outcome. *J Viral Hepat* 2008;15:165-72. (Abstract)



- Castelnau C, Le Gal F, Ripault MP, Gordien E, Martinot-Peignoux M, Boyer N, et al. Efficacy of peginterferon alpha-2b in chronic hepatitis delta: relevance of quantitative RT-PCR for follow-up. *Hepatology* 2006;44:728-35. (Abstract)
- Cross TJ, Rizzi P, Horner M, et al. The increasing prevalence of hepatitis delta virus (HDV) infection in South London. *J Med Virol* 2008;80:277-82. (Abstract)
- Dienes HP, Purcell RH, Popper H, Ponzetto A. The significance of infections with two types of viral hepatitis demonstrated by histologic features in chimpanzees. *J Hepatol* 1990;10:77-84. (Abstract)
- Degertekin H, Yalcin K, Yakut M, Yurdaydin C. Seropositivity for delta hepatitis in patients with chronic hepatitis B and liver cirrhosis in Turkey: a meta-analysis. *Liver Int* 2008;28:494-98. (Abstract)
- Deterding K, Pothakamuri SV, Schlaphoff V, et al. Clearance of chronic HCV infection during acute delta hepatitis. *Infection* 2009;37:159-62. (Abstract)
- Erhardt A, Knuth R, Sagir A, Kirschberg O, Heintges T, Haussinger D. Socioepidemiological data on hepatitis delta in a German university clinic--increase in patients from Eastern Europe and the former Soviet Union. *Z Gastroenterol* 2003;41:523-6. (Abstract)
- Erhardt A, Gerlich W, Starke C, Wend U, Donner A, Sagir A, et al. Treatment of chronic hepatitis delta with pegylated interferon-alpha2b. *Liver Int* 2006;26:805-10. (Abstract)
- Farci P, Mandas A, Coiana A, Lai ME, Desmet V, Van Eyken P, et al. Treatment of chronic hepatitis D with interferon alfa-2a. *N Engl J Med* 1994;330:88-94. (Abstract)
- Farci P, Roskams T, Chessa L, Peddis G, Mazzoleni AP, Scioscia R, et al. Long-term benefit of interferon alpha therapy of chronic hepatitis D: regression of advanced hepatic fibrosis. *Gastroenterology* 2004;126:1740-9. (Abstract)
- Fattovich G, Boscaro S, Noventa F, Pornaro E, Stenico D, Alberti A, et al. Influence of hepatitis delta virus infection on progression to cirrhosis in chronic hepatitis type B. *J Infect Dis* 1987;155:931-5. (Abstract)
- Fattovich G, Giustina G, Christensen E, Pantalena M, Zagni I, Realdi G, et al. Influence of hepatitis delta virus infection on morbidity and mortality in compensated cirrhosis type B. The European Concerted Action on Viral Hepatitis (Eurohep). *Gut* 2000;46:420-6. (Abstract)
- Flodgren E, Bengtsson S, Knutsson M, Strebkova EA, Kidd AH, Alexeyev OA, et al. Recent high incidence of fulminant hepatitis in Samara, Russia: molecular analysis of prevailing hepatitis B and D virus strains. *J Clin Microbiol* 2000;38:3311-6. (Abstract)
- Gaeta GB, Stroffolini T, Chiaramonte M, Ascione T, Stornaiuolo G, Lobello S, et al. Chronic hepatitis D: a vanishing disease? An Italian multicenter study. *Hepatology* 2000;32(4 Pt 1):824-7. (Abstract)
- Garripoli A, Di Marco V, Cozzolongo R, et al. Ribavirin treatment for chronic hepatitis D: a pilot study. *Liver* 1994;14:154-7. (Abstract)
- Grabowski J, Yurdaydin C, Zachou K, et al. Hepatitis D virus-specific cytokine responses in patients with chronic hepatitis delta before and during interferon alfa-treatment. *Liver Int* 2011;31:1395-405. (Abstract)
- Gunsar F, Akarca US, Ersoz G, Kobak AC, Karasu Z, Yuce G, et al. Two-year interferon therapy with or without ribavirin in chronic delta hepatitis. *Antivir Ther* 2005;10:721-6. (Abstract)
- Hadziyannis SJ. Review: hepatitis delta. *J Gastroenterol Hepatol* 1997;12:289-98. (Abstract)
- Heidrich B, Deterding K, Tillmann HL, Raupach R, Manns MP, Wedemeyer H. Virological and clinical characteristics of delta hepatitis in Central Europe. *J Viral Hepat* 2009;16:883-94. (Abstract)
- Hershow RC, Chomel BB, Graham DR, Schyve PM, Mandel EJ, Kane MA, et al. Hepatitis D virus infection in Illinois state facilities for the developmentally disabled. *Epidemiology and clinical manifestations*. *Ann Intern Med* 1989;110:779-85. (Abstract)
- Huang YH, Tao MH, Hu CP, Syu WJ, Wu JC. Identification of novel HLA-A\*0201-restricted CD8+ T-cell epitopes on hepatitis delta virus. *J Gen Virol* 2004;85(Pt 10):3089-3098. (Abstract)
- Hughes SA, Wedemeyer H, Harrison PM. Hepatitis delta virus. *Lancet* 2011;378:73-85. (Abstract)
- Janssen HL, van Zonneveld M, Senturk H, et al. Pegylated interferon alfa-2b alone or in combination with lamivudine for HBeAg-positive chronic hepatitis B: a randomised trial. *Lancet* 2005;365:123-9. (Abstract)

- Jardi R, Rodriguez F, Buti M, Costa X, Cotrina M, Galimany R, et al. Role of hepatitis B, C, and D viruses in dual and triple infection: influence of viral genotypes and hepatitis B precore and basal core promoter mutations on viral replicative interference. *Hepatology* 2001;34:404-410. ([Abstract](#))
- Lau DT (a), Kleiner DE, Park Y, Di Bisceglie AM, Hoofnagle JH. Resolution of chronic delta hepatitis after 12 years of interferon alfa therapy. *Gastroenterology* 1999;117:1229-33. ([Abstract](#))
- Lau DT (b), Doo E, Park Y, Kleiner DE, Schmid P, Kuhns MC, et al. Lamivudine for chronic delta hepatitis. *Hepatology* 1999;30:546-9.
- Le Gal F, Castelneau C, Gault E, et al. Hepatitis D virus infection-not a vanishing disease in Europe! *Hepatology* 2007;45:1332-3. ([Abstract](#))
- Lutgehetmann M, Mancke LV, Volz T, et al. Human chimeric uPA mouse model to study hepatitis B and D virus interactions and preclinical drug evaluation. *Hepatology* 2011; doi: 10.1002/hep.24758. [Epub ahead of print] ([Abstract](#))
- Manns MP, Wedemeyer H, Cornberg M. Treating viral hepatitis C: efficacy, side effects, and complications. *Gut* 2006;55:1350-59. ([Abstract](#))
- Manesis EK, Schina M, Le Gal F, Agelopoulos O, Papaioannou C, Kalligeros C, et al. Quantitative analysis of hepatitis D virus RNA and hepatitis B surface antigen serum levels in chronic delta hepatitis improves treatment monitoring. *Antivir Ther* 2007;12:381-8. ([Abstract](#))
- Mederacke I, Bremer B, Heidrich B, et al. Establishment of a novel quantitative hepatitis D virus (HDV) RNA assay using the Cobas TaqMan platform to study HDV RNA kinetics. *J Clin Microbiol* 2010;48:2022-9. ([Abstract](#))
- Mederacke I, Yurdaydin C, Großhennig A, et al. Renal function during treatment with adefovir plus peginterferon alfa-2a vs either drug alone in hepatitis B/D co-infection. *J Viral Hepat* 2012; in press.
- Mederacke I, Filmann N, Yurdaydin C, et al. Rapid early HDV RNA decline in the peripheral blood but prolonged intrahepatic hepatitis delta antigen persistence after liver transplantation. *J Hepatol* 2012;56:115-22. ([Abstract](#))
- Mele A, Mariano A, Tosti ME, Stroffolini T, et al. Acute hepatitis delta virus infection in Italy: incidence and risk factors after the introduction of the universal anti-hepatitis B vaccination campaign. *Clin Infect Dis* 2007; 44:e17-24. ([Abstract](#))
- Nakano T, Shapiro CN, Hadler SC, Casey JL, Mizokami M, Orito E, et al. Characterization of hepatitis D virus genotype III among Yucpa Indians in Venezuela. *J Gen Virol* 2001;82(Pt 9):2183-2189. ([Abstract](#))
- Negro F, Bergmann KF, Baroudy BM, et al. Chronic hepatitis D virus (HDV) infection in hepatitis B virus carrier chimpanzees experimentally superinfected with HDV. *J Infect Dis* 1988;158:151-9. ([Abstract](#))
- Niro GA, Casey JL, Gravinese E, Garrubba M, Conoscitore P, Sagnelli E, et al. Intrafamilial transmission of hepatitis delta virus: molecular evidence. *J Hepatol* 1999;30:564-9. ([Abstract](#))
- Niro GA (a), Ciancio A, Tillman HL, Lagget M, Olivero A, Perri F, et al. Lamivudine therapy in chronic delta hepatitis: a multicentre randomized-controlled pilot study. *Aliment Pharmacol Ther* 2005;22:227-32. ([Abstract](#))
- Niro GA (b), Rosina F, Rizzetto M. Treatment of hepatitis D. *J Viral Hepat* 2005;12:2-9. ([Abstract](#))
- Niro GA, Ciancio A, Gaeta GB, Smedile A, Marrone A, Olivero A, et al. Pegylated interferon alpha-2b as monotherapy or in combination with ribavirin in chronic hepatitis delta. *Hepatology* 2006;44:713-20. ([Abstract](#))
- Niro GA, Smedile A, Ippolito AM, et al. Outcome of chronic delta hepatitis in Italy: a long-term cohort study. *J Hepatol* 2010;53:834-40. ([Abstract](#))
- Niro GA, Gioffreda D, Fontana R. Hepatitis delta virus infection: open issues. *Dig Liver Dis* 2011;43 Suppl 1:S19-24. ([Abstract](#))
- Nisini R, Paroli M, Accapezzato D, Bonino F, Rosina F, Santantonio T, et al. Human CD4+ T-cell response to hepatitis delta virus: identification of multiple epitopes and characterization of T-helper cytokine profiles. *J Virol* 1997;71:2241-51. ([Abstract](#))
- Ormeci N, Bolukbas F, Erden E, et al. Pegylated interferon alfa-2B for chronic delta hepatitis: 12 versus 24 months. *Hepatogastroenterology* 2011;58:1648-53. ([Abstract](#))
- Petersen J, Dandri M, Mier W, et al. Prevention of hepatitis B virus infection in vivo by entry inhibitors derived from the large envelope protein. *Nat Biotechnol* 2008;26:335-41. ([Abstract](#))

- Radjef N, Gordien E, Ivaniushina V, Gault E, Anais P, Drugan T, et al. Molecular phylogenetic analyses indicate a wide and ancient radiation of African hepatitis delta virus, suggesting a deltavirus genus of at least seven major clades. *J Virol* 2004;78:2537-44. (Abstract)
- Raimondo G, Brunetto MR, Pontisso P, Smedile A, Maina AM, Saitta C, et al. Longitudinal evaluation reveals a complex spectrum of virological profiles in hepatitis B virus/hepatitis C virus-coinfected patients. *Hepatology* 2006;43:100-7. (Abstract)
- Rizzetto M. The delta agent. *Hepatology* 1983;3:729-37. (Abstract)
- Rizzetto M, Rosina F, Saracco G, Bellando PC, Actis GC, Bonino F, et al. Treatment of chronic delta hepatitis with alpha-2 recombinant interferon. *J Hepatol* 1986;3 Suppl 2:S229-33. (Abstract)
- Rizzetto M. Hepatitis D: thirty years after. *J Hepatol* 2009;50:1043-50. (Abstract)
- Romeo R, Del Ninno E, Rumi M, et al. A 28-year study of the course of hepatitis Delta infection: a risk factor for cirrhosis and hepatocellular carcinoma. *Gastroenterology* 2009;136:1629-38. (Abstract)
- Rosenau J, Kreuz T, Kujawa M, et al. HBsAg level at time of liver transplantation determines HBsAg decrease and anti-HBs increase and affects HBV DNA decrease during early immunoglobulin administration. *J Hepatol* 2007;46:635-44. (Abstract)
- Sagnelli E, Coppola N, Scolastico C, Filippini P, Santantonio T, Stroffolini T et al. Virologic and clinical expressions of reciprocal inhibitory effect of hepatitis B, C, and delta viruses in patients with chronic hepatitis. *Hepatology* 2000;32:1106-10. (Abstract)
- Samuel D, Muller R, Alexander G, et al. Liver transplantation in European patients with the hepatitis B surface antigen. *N Engl J Med* 1993;329:1842-7. (Abstract)
- Schaper M, Rodriguez-Frias F, Jardi R, et al. Quantitative longitudinal evaluations of hepatitis delta virus RNA and hepatitis B virus DNA shows a dynamic, complex replicative profile in chronic hepatitis B and D. *J Hepatol* 2010;52:658-64. (Abstract)
- Sheldon J, Ramos B, Toro C, Rios P, Martinez-Alarcon J, Bottecchia M, et al. Does treatment of hepatitis B virus (HBV) infection reduce hepatitis delta virus (HDV) replication in HIV-HBV-HDV-coinfected patients? *Antivir Ther* 2008;13:97-102. (Abstract)
- Sheng WH, Hung CC, Kao JH, Chang SY, Chen MY, Hsieh SM, et al. Impact of hepatitis D virus infection on the long-term outcomes of patients with hepatitis B virus and HIV coinfection in the era of highly active antiretroviral therapy: a matched cohort study. *Clin Infect Dis* 2007;44:988-95. (Abstract)
- Smedile A, Casey JL, Cote PJ, et al. Hepatitis D viremia following orthotopic liver transplantation involves a typical HDV virion with a hepatitis B surface antigen envelope. *Hepatology* 1998;27:1723-9. (Abstract)
- Soriano V, Grint D, d'Arminio Monforte A, et al. Hepatitis delta in HIV-infected individuals in Europe. *AIDS* 2011;25:1987-92. (Abstract)
- Su CW, Huang YH, Huo TI, Shih HH, Sheen IJ, Chen SW, et al. Genotypes and viremia of hepatitis B and D viruses are associated with outcomes of chronic hepatitis D patients. *Gastroenterology* 2006;130:1625-35. (Abstract)
- Taylor JM. Hepatitis delta virus. *Virology* 2006;344:71-6. (Abstract)
- Tsatsralt-Od B, Takahashi M, Nishizawa T, Endo K, Inoue J, Okamoto H. High prevalence of dual or triple infection of hepatitis B, C, and delta viruses among patients with chronic liver disease in Mongolia. *J Med Virol* 2005;77:491-99. (Abstract)
- Tsatsralt-Od B, Takahashi M, Endo K, Buyankhuu O, Baatarkhuu O, Nishizawa T, et al. Infection with hepatitis A, B, C, and delta viruses among patients with acute hepatitis in Mongolia. *J Med Virol* 2006;78:542-50. (Abstract)
- Troisi CL, Hollinger FB, Hoots WK, Contant C, Gill J, Ragni M, et al. A multicenter study of viral hepatitis in a United States hemophilic population. *Blood* 1993;81:412-18. (Abstract)
- Uzunalioglu O, Yurdaydin C, Cetinkaya H, Bozkaya H, Sahin T, Colakoglu S, et al. Risk factors for hepatocellular carcinoma in Turkey. *Dig Dis Sci* 2001;46:1022-28. (Abstract)
- Wedemeyer H, Boker KH, Pethig K, Petzold DR, Flemming P, Tillmann HL, et al. Famciclovir treatment of chronic hepatitis B in heart transplant recipients: a prospective trial. *Transplantation* 1999;68:1503-11. (Abstract)
- Wedemeyer H., Yurdaydin C. Delta Hepatitis. In: Tillman HL, editor. *Handbuch Hepatitis B: Diagnostik, Verlauf, Therapie*. Bremen: Uni-Med, 2007: 96-103.
- Wedemeyer H, Heidrich B, Manns MP. Hepatitis D virus infection - Not a vanishing disease in Europe! *Hepatology* 2007;45:1331-1332. (Abstract)

- Wedemeyer H, Manns MP. Epidemiology, pathogenesis and management of hepatitis D: update and challenges ahead. *Nat Rev Gastroenterol Hepatol* 2010;7:31-40. ([Abstract](#))
- Wedemeyer H. Re-emerging interest in hepatitis delta: new insights into the dynamic interplay between HBV and HDV. *J Hepatol* 2010;52:627-9. ([Abstract](#))
- Weisfuse IB, Hadler SC, Fields HA, Alter MJ, O'Malley PM, Judson FN, et al. Delta hepatitis in homosexual men in the United States. *Hepatology* 1989;9:872-4. ([Abstract](#))
- Williams V, Brichler S, Radjef N, et al. Hepatitis delta virus proteins repress hepatitis B virus enhancers and activate the alpha/beta interferon-inducible MxA gene. *J Gen Virol* 2009;90:2759-67. ([Abstract](#))
- Wolters LM, van Nunen AB, Honkoop P, Vossen AC, Niesters HG, Zondervan PE, et al. Lamivudine-high dose interferon combination therapy for chronic hepatitis B patients co-infected with the hepatitis D virus. *J Viral Hepat* 2000;7:428-34. ([Abstract](#))
- Yakut M, Seven G, Baran B, et al. Clevudine treatment of chronic delta hepatitis. *J Hepatol* 2010;52 Suppl 1:473.
- Yurdaydin C, Bozkaya H, Gurel S, Tillmann HL, Aslan N, Okcu-Heper A, et al. Famciclovir treatment of chronic delta hepatitis. *J Hepatol* 2002;37:266-71. ([Abstract](#))
- Yurdaydin C. Delta hepatitis in Turkey: decreasing but not vanishing and still of concern. *Turk J Gastroenterol* 2006;17:74-5. ([Abstract](#))
- Yurdaydin C (b), Bozkaya H, Onder FO, Senturk H, Karaaslan H, Akdogan M, et al. Treatment of chronic delta hepatitis with lamivudine vs lamivudine + interferon vs interferon. *J Viral Hepat* 2008;15:314-21. ([Abstract](#))
- Zachou K, Yurdaydin C, Drebber U, et al. Quantitative HBsAg and HDV-RNA levels in chronic delta hepatitis. *Liver Int* 2010;30:430-7. ([Abstract](#))

## 12. Hepatitis C: Diagnostic Tests

*Christian Lange and Christoph Sarrazin*

Common symptoms of hepatitis C like fatigue, muscle ache, loss of appetite or nausea are unspecific and, in many cases, mild or not present. Consequently, hepatitis C is often diagnosed accidentally and, unfortunately, remains heavily under-diagnosed. It is estimated that only 30-50% of individuals infected with HCV are aware of their disease and can take advantage of treatment options and avoid the risk of further transmission of the virus (Deuffic-Burban 2010). Untreated hepatitis C advances to a chronic state in up to 80% of people, which leads to liver cirrhosis in 20-40% with an accompanying risk of hepatic decompensation, hepatocellular carcinoma and death (McHutchison 2004). In light of these facts, HCV diagnostics should be performed thoroughly in all patients presenting with increased aminotransferase levels, with chronic liver disease of unclear etiology and with a history of enhanced risk of HCV transmission (i.e., past IV or nasal drug dependency, transmission of blood or blood products before the year 1990, major surgery before 1990, needle stick injuries, non-sterile tattoos or piercings, enhanced risk of sexual transmission).

For the diagnosis of hepatitis C both serologic and nucleic acid-based molecular assays are available (Scott 2007). Serologic tests are sufficient when chronic hepatitis C is expected, with a sensitivity of more than 99% in the 3rd generation assays. Positive serologic results require HCV RNA measurement in order to differentiate between chronic hepatitis C and resolved HCV infection from the past. When acute hepatitis C is considered, serologic screening alone is insufficient because anti-HCV antibodies may develop late after transmission of the virus. In contrast, HCV RNA is detectable within a few days of infection, making nucleic acid-based tests mandatory in diagnosing acute hepatitis C. HCV RNA measurement is furthermore essential in the determination of treatment indication, duration and success (Terrault 2005). The latter has to be confirmed at clearly defined times during treatment to decide whether therapy should be continued or not. It should be repeated 24 weeks after treatment completion to assess whether a sustained virologic response (SVR) has been achieved. Both qualitative and quantitative HCV RNA detection assays are available. Qualitative tests are highly sensitive and are used for diagnosing hepatitis C for the first time, for the screening of blood and organ donations and for confirming SVR after treatment completion. Quantitative HCV RNA detection assays offer the possibility of measuring the viral load exactly and are essential in treatment monitoring. Qualitative and quantitative

HCV RNA assays are now being widely replaced by real-time PCR-based assays that can detect HCV RNA over a very wide range, from low levels of approximately 10 IU/ml up to 10 million IU/ml.

After diagnosing hepatitis C, the HCV genotype should be determined by nucleic acid-based techniques in every patient considered for HCV therapy, because the currently recommended treatment schedules and durations as well as the specific ribavirin doses differ among the genotypes.

Morphological methods like immunohistochemistry, *in situ* hybridization or PCR from liver specimens play no relevant role in the diagnosis of hepatitis C because of their low sensitivity, poor specificity and low efficacy compared to serologic and nucleic acid-based approaches.

## Serologic assays

In current clinical practice, antibodies against multiple HCV epitopes are detected by commercially available 2nd and 3rd generation enzyme-linked immunoassays (EIAs). In these tests, HCV-specific antibodies from serum samples are captured by recombinant HCV proteins and are then detected by secondary antibodies against IgG or IgM. These secondary antibodies are labelled with enzymes that catalyse the production of coloured, measurable compounds.

The first applied EIAs for the detection of HCV-specific antibodies were based on epitopes derived from the NS4 region (C-100) and had a sensitivity of 70–80% and a poor specificity (Scott 2007). C-100-directed antibodies occur approximately 16 weeks after viral transmission. 2nd generation EIAs additionally detect antibodies against epitopes derived from the core region (C-22), NS3 region (C-33) and NS4 region (C-100), which leads to an increased sensitivity of approximately 95% and to a lower rate of false-positive results. With these assays HCV-specific antibodies can be detected approximately 10 weeks after HCV infection (Pawlotsky 2003). To narrow the diagnostic window from viral transmission to positive serological results, a 3<sup>rd</sup> generation EIA has been completed by an antigen from the NS5 region and/or the substitution of a highly immunogenic NS3 epitope. This innovation allows the detection of anti-HCV antibodies approximately four to six weeks after infection with a sensitivity of more than 99% (Colin 2001). Anti-HCV IgM measurement can narrow the diagnostic window in only a minority of patients. Anti-HCV IgM detection is also not sufficient to discriminate between acute and chronic hepatitis C because some chronically infected patients produce anti-HCV IgM intermittently and not all patients respond to acute HCV infection by producing anti-HCV IgM.

The specificity of serologic HCV diagnostics is difficult to define since an appropriate gold standard is lacking. It is evident, however, that false-positive results are more frequent in patients with rheuma-factors and in populations with a low hepatitis C prevalence, for example in blood and organ donors. Although several immunoblots for the confirmation of positive HCV EIA results are available, these tests have lost their clinical importance since the development of highly sensitive methods for HCV RNA detection. Immunoblots are mandatory to make the exact identification of serologically false-positive-tested individuals possible. Importantly, the sensitivity of immunoblotting is lower compared to EIAs, which bears the risk of the false-negatively-classifying of HCV-infected individuals.

False-negative HCV antibody testing may occur in patients on hemodialysis or in severely immunosuppressed patients like in HIV infection or in hematological malignancies.

### **HCV core antigen assays**

In principle, detection of the HCV core antigen in serum could be a cheaper alternative to nucleic acid testing for the diagnosis and management of hepatitis C. However, the introduction of a reliable and sensitive HCV core antigen assay is burdened with a number of difficulties like the development of specific monoclonal antibodies recognizing all different HCV subtypes and the need for accumulation and dissociation of HCV particles from immune complexes to increase sensitivity. The first HCV core antigen detection system (trak-C, Ortho Clinical Diagnostics) became commercially available in the US and Europe several years ago. This HCV core antigen assay proved highly specific (99.5%), genotype independent, and had a low inter- and intra-assay variability (coefficient of variation 5–9%) (Veillon 2003). HCV core antigen is measurable 1–2 days after HCV RNA becomes detectable. The limit of detection is 1.5 pg/ml (approximately 10,000–50,000 IU/ml HCV RNA). In a study of anti-HCV antibody and HCV RNA- positive patients presenting in an outpatient clinic, 6/139 people (4%) were HCV core antigen negative. In these patients, HCV RNA concentrations were 1300–58,000 IU/ml highlighting the limitations of the HCV core antigen assay as confirmation of ongoing hepatitis C in anti-HCV-positive patients. As a consequence, this first HCV core antigen assay was withdrawn from the market.

More recently, another quantitative HCV core antigen assay (Architect HCV Ag, Abbott Diagnostics), a further development of the previous assay, was approved by the EMA. This assay comprises 5 different antibodies to detect HCV core antigen, is highly specific (99.8%), equally effective for different HCV genotypes, and shows a relatively low sensitivity for determination of chronic hepatitis C (corresponding to 600–1000 IU/ml HCV RNA). However, HCV core antigen correlated well but not fully linearly with HCV RNA serum levels, and false-negative results were obtained in patients with impaired immunity (Mederacke 2009, Medici 2011). Taken together, the new HCV core antigen assay could be a cheaper, though somewhat less sensitive alternative for nucleic acid testing. For careful monitoring of treatment with standard dual combination therapies or directly acting antiviral agents, prospective studies have to be performed to determine proper rules and time points for response-guided treatment algorithms.

### **Nucleic acid testing for HCV**

Until 1997, HCV quantitative results from various HCV RNA detection systems did not represent the same concentration of HCV RNA in a clinical sample. Because of the importance of an exact HCV RNA load determination for management of patients, the World Health Organization (WHO) established the HCV RNA international standard based on international units (IU) which is used in all clinically applied HCV RNA tests. Other limitations of earlier HCV RNA detection assays were false-negative results due to polymerase inhibition, for example by drug interference, false-positive results due to sample contamination because the reaction tubes had to be opened frequently, or due to under- and over-quantification of

samples of certain HCV genotypes (Morishima 2004, Pawlotsky 2003, Pawlotsky 1999). Currently, several HCV RNA assays are commercially available (Table 1).

**Table 1. Commercially available HCV RNA detection assays.**

Assay	Distributor	Technology	Approval status
<b>Qualitative HCV RNA detection assays</b>			
Amplicor™ HCV 2.0	Roche Molecular Systems	PCR	FDA, CE
Versant™ HCV	Siemens Medical Solutions Diagnostics	TMA	FDA, CE
<b>Quantitative HCV RNA detection assays</b>			
Amplicor™ HCV Monitor 2.0	Roche Molecular Systems	PCR	CE
HCV SuperQuant™	National Genetics Institute	PCR	
Versant™ HCV RNA 3.0	Siemens Medical Solutions Diagnostics	bDNA	FDA, CE
Cobas Ampliprep/ High pure system /Cobas TaqMan	Roche Molecular Systems	Real-time PCR	FDA, CE
Abbott RealTime™ HCV	Abbott Diagnostics	Real-time PCR	FDA, CE

## Qualitative assays for HCV RNA detection

Until recently, qualitative assays for HCV RNA had substantially lower limits of detection in comparison with quantitative HCV RNA assays. The costs of a qualitative assay are also lower compared to a quantitative assay. Therefore, qualitative HCV RNA tests are used for the first diagnosis of acute hepatitis C, in which HCV RNA concentrations are fluctuating and may be very low, as well as for confirmation of chronic hepatitis C infection in patients with positive HCV antibodies. In addition, they are used for the confirmation of virologic response during, at the end of, and after antiviral therapy, as well as in screening blood and organ donations for presence of HCV.

## Qualitative RT-PCR

In reverse transcriptase-PCR- (RT-PCR-) based assays, HCV RNA is used as a matrix for the synthesis of a single-stranded complementary cDNA by reverse transcriptase. The cDNA is then amplified by a DNA polymerase into multiple double-stranded DNA copies. Qualitative RT-PCR assays are expected to detect 50 HCV RNA IU/ml or less with equal sensitivity for all genotypes.

The Amplicor™ HCV 2.0 is an FDA- and CE-approved RT-PCR system for qualitative HCV RNA testing that allows detection of HCV RNA concentrations down to 50 IU/ml of all genotypes (Table 1) (Nolte 2001). The DNA polymerase of *Thermus thermophilus* used in this assay provides both DNA polymerase and reverse transcriptase activity and allows HCV RNA amplification and detection in a single-step, single-tube procedure.

## Transcription-mediated amplification (TMA) of HCV RNA

TMA-based qualitative HCV RNA detection has a very high sensitivity (Hendricks 2003, Sarrazin 2002). TMA is performed in a single tube in three steps: target capture, target amplification and specific detection of target amplicons by a hybridization protection assay. Two primers, one of which contains a T7 promoter,



one T7 RNA polymerase and one reverse transcriptase, are necessary for this procedure. After RNA extraction from 500µl serum, the T7 promoter-containing primer hybridises the viral RNA with the result of reverse transcriptase-mediated cDNA synthesis. The reverse transcriptase also provides an RNase activity that degrades the RNA of the resulting RNA/DNA hybrid strand. The second primer then binds to the cDNA that already contains the T7 promoter sequence from the first primer, and a DNA/DNA double-strand is synthesised by the reverse transcriptase. Next, the RNA polymerase recognizes the T7 promoter and produces 100-1000 RNA transcripts, which are subsequently returned to the TMA cycle leading to exponential amplification of the target RNA. Within one hour, approximately 10 billion amplicons are produced. The RNA amplicons are detected by a hybridisation protection assay with amplicon-specific labelled DNA probes. The unhybridised DNA probes are degraded during a selection step and the labelled DNA is detected by chemiluminescence.

A commercially available TMA assay is the Versant™ HCV RNA Qualitative Assay. This system is accredited by the FDA and CE and provides an extremely high sensitivity, superior to RT-PCR-based qualitative HCV RNA detection assays (Hofmann 2005, Sarrazin 2001, Sarrazin 2000). The lower detection limit is 5-10 IU/ml with a sensitivity of 96-100%, and a specificity of more than 99.5%, independent of the HCV genotype.

## Quantitative HCV RNA detection

HCV RNA quantification can be achieved either by target amplification techniques (competitive and real-time PCR) or by signal amplification techniques (branched DNA (bDNA) assay) (Table 1). Several FDA- and CE-approved standardised systems are commercially available. The Cobas Amplicor™ HCV Monitor is based on a competitive PCR technique whereas the Versant™ HCV RNA Assay is based on a bDNA technique. More recently, the Cobas® TaqMan® assay and the Abbott RealTime™ HCV test, both based on real-time PCR technology, have been introduced. The technical characteristics, detection limits and linear dynamic detection ranges of these systems are summarized below. Due to their very low detection limit and their broad and linear dynamic detection range, they have already widely replaced the previously used qualitative and quantitative HCV RNA assays.

### Competitive PCR: Cobas® Amplicor HCV 2.0 monitor

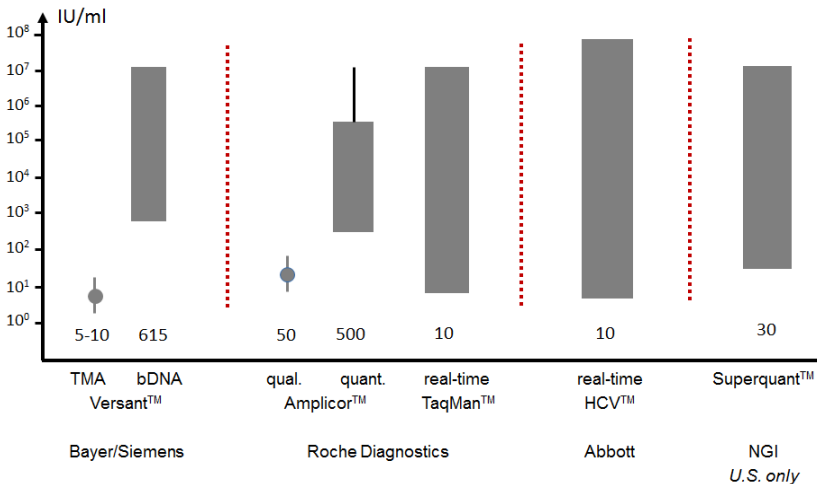
The Cobas® Amplicor HCV 2.0 monitor is a semi-automated quantitative detection assay based on a competitive PCR technique. Quantification is achieved by the amplification of two templates in a single reaction tube, the target and the internal standard. The latter is an internal control RNA with nearly the same sequence as the target RNA with a clearly defined initial concentration. The internal control is amplified by the same primers as the HCV RNA. Comparison of the final amounts of both templates allows calculation of the initial amount of HCV RNA. The dynamic range of the Amplicor HCV 2.0 monitor assay is 500 to approximately 500,000 IU/ml with a specificity of almost 100%, independent of the HCV genotype (Konnick 2002, Lee 2000). For higher HCV RNA concentrations pre-dilution of the original sample is required.

## Branched DNA hybridisation assay (Versant<sup>®</sup> HCV RNA 3.0 quantitative assay)

Branched DNA hybridisation assay is based on signal amplification technology. After reverse transcription of the HCV RNA, the resulting single-stranded complementary DNA strands bind to immobilised captured oligonucleotides with a specific sequence from conserved regions of the HCV genome. In a second step, multiple oligonucleotides bind to the free ends of the bound DNA strands and are subsequently hybridised by multiple copies of an alkaline phosphatase-labelled DNA probe. Detection is achieved by incubating the alkaline phosphatase-bound complex with a chemiluminescent substrate (Sarrazin 2002). The Versant HCV RNA assay is at present the only FDA- and CE-approved HCV RNA quantification system based on a branched DNA technique. The lower detection limit of the current version 3.0 is 615 IU/ml and linear quantification is ensured between 615–8,000,000 IU/ml, independent of the HCV genotype (Morishima 2004). The bDNA assay only requires 50  $\mu$ l serum for HCV RNA quantification and is currently the assay with the lowest sample input.

## Real-time PCR-based HCV RNA detection assays

Real-time PCR technology provides optimal features for both HCV RNA detection and quantification because of its very low detection limit and broad dynamic range of linear amplification (Sarrazin 2006) (Figure 1). Distinctive for real-time PCR technology is the ability to simultaneously amplify and detect the target nucleic acid, allowing direct monitoring of the PCR process. RNA templates are first reverse-transcribed to generate complementary cDNA strands followed by a DNA polymerase-mediated cDNA amplification.



**Figure 1. Detection limits and linear dynamic ranges of commercially available HCV RNA detection assays.**

DNA detection simultaneous to amplification is preferentially achieved by the use of target sequence-specific oligonucleotides linked to two different molecules, a fluorescent reporter molecule and a quenching molecule. These probes bind the

target cDNA between the two PCR primers and are degraded or released by the DNA polymerase during DNA synthesis. In case of degradation the reporter and quencher molecules are released and separated, which results in the emission of an increased fluorescence signal from the reporter. Different variations of this principle of reporter and quencher are used by the different commercially available assays. The fluorescence signal, intensified during each round of amplification, is proportional to the amount of RNA in the starting sample. Quantification in absolute numbers is achieved by comparing the kinetics of the target amplification with the amplification kinetics of an internal control of a defined initial concentration.

Highly effective and almost completely automated real-time PCR-based systems for HCV RNA measurement have been introduced. For replacement of the qualitative TMA and the quantitative bDNA-based assays, a real-time based PCR test (Versant<sup>®</sup> kPCR Molecular System) is being developed.

All commercially available HCV RNA assays are calibrated to the WHO standard based on HCV genotype 1. Significant differences between different RT-PCR assays and other quantitative HCV RNA tests have been reported - in the case of the real-time PCR-based assays a slight under-quantification by one assay and a slight over-quantification by the other, in comparison to the WHO standard by Cobas<sup>®</sup> TaqMan<sup>®</sup>. In addition, it has been shown that results may vary significantly between assays with different HCV genotypes despite standardisation to IU (Chevaliez 2007, Vehrmeren 2008).

### **Cobas<sup>®</sup> TaqMan<sup>®</sup> HCV test**

The FDA- and CE-accredited Cobas<sup>®</sup> TaqMan<sup>®</sup> (CTM) assay uses reporter- and quencher-carrying oligonucleotides specific to the 5'UTR of the HCV genome and to the template of the internal control, a synthetic RNA for binding the same primers as for HCV RNA. Reverse transcription and cDNA amplification is performed by the Z05 DNA polymerase. For HCV RNA extraction from serum or plasma samples, a Cobas<sup>®</sup> TaqMan<sup>®</sup> assay was developed either in combination with the fully automated Cobas<sup>®</sup> Ampliprep (CAP) instrument using magnetic particles, or in combination with manual HCV RNA extraction with glass fiber columns using the high pure system (HPS) viral nucleic acid kit. The current versions of both combinations have a lower detection limit of approximately 10 IU/ml and a linear amplification range of HCV RNA from approximately 40 to 10,000,000 IU/ml. Samples from HCV genotypes 2-5 have been shown to be under-quantified by the first version of the HPS-based Cobas<sup>®</sup> TaqMan<sup>®</sup> assay. The recently released second version of this assay has now demonstrated equal quantification of all HCV genotypes (Colucci 2007). For the Cobas<sup>®</sup> Ampliprep/ Cobas<sup>®</sup> TaqMan<sup>®</sup> (CAP/CTM) assay significant under-quantification of HCV genotype 4 samples has been shown. However, a prototype second version of this assay was able to accurately quantify HCV RNA samples from patients infected with all HCV genotypes, including HCV genotype 4 transcripts with rare sequence variants that had been under-quantified by the first generation assay (Vermehren 2011). The second version CAP/CTM assay will be commercially available in 2012. Taken together, the Cobas<sup>®</sup> TaqMan<sup>®</sup> assay makes both highly sensitive qualitative and linear quantitative HCV RNA detection feasible with excellent performance in one system with complete automation.

## RealTime HCV test

The CE-accredited RealTime HCV Test uses reporter- and quencher-carrying oligonucleotides specific for the 5'UTR as well. HCV RNA concentrations are quantified by comparison with the amplification curves of a cDNA from the hydroxypyruvate reductase gene from the pumpkin plant *Curcubita pepo*, which is used as an internal standard. This internal standard is amplified with different primers from those of the HCV RNA, which may be the reason for the linear quantification of very low HCV RNA concentrations. The RealTime HCV Test provides a lower detection limit of approximately 10 IU/ml, a specificity of more than 99.5% and a linear amplification range from 12 to 10,000,000 IU/ml independent of the HCV genotype (Vehrmereen 2008; Michelin 2007; Sabato 2007). In a recent multi-centre study, its clinical utility to monitor antiviral therapy of patients infected with HCV genotypes 1, 2 and 3 has been proven and the FDA consequently approved the RealTime HCV Test (Vermehren 2011). In this study, highly concordant baseline HCV RNA levels as well as highly concordant data on rapid and early virologic response were obtained compared to reference tests for quantitative and qualitative HCV RNA measurement, the Versant<sup>®</sup> HCV Quantitative 3.0 branched DNA hybridization assay and the Versant<sup>®</sup> HCV RNA Qualitative assay, respectively.

## HCV genotyping

HCV is heterogeneous with an enormous genomic sequence variability, developed due to a rapid replication cycle with the production of  $10^{12}$  virions per day and the low fidelity of the HCV RNA polymerase. Six genotypes (1-6), multiple subtypes (a, b, c...) and most recently a seventh HCV genotype have been characterized. These genotypes vary in approximately 30% of their RNA sequence with a median variability of approximately 33%. HCV subtypes are defined by differences in their RNA sequence of approximately 10%. Within one subtype, numerous quasispecies exist and may emerge during treatment with specific antivirals. These quasispecies are defined by a sequence variability of less than 10% (Simmonds 2005). Because the currently recommended treatment durations and ribavirin doses depend on the HCV genotype, HCV genotyping is mandatory in every patient who considers antiviral therapy (Bowden 2006). For triple therapies with HCV protease inhibitors and future multiple direct acting antiviral combination therapies, determination of HCV subtypes is of importance because of significant different barriers to resistance on the HCV subtype level.

Both direct sequence analysis and reverse hybridisation technology allow HCV genotyping. Initial assays were designed to analyse exclusively the 5' untranslated region (5'UTR), which is burdened with a high rate of misclassification especially on the subtype level. Current assays were improved by additionally analyzing the coding regions, in particular the genes encoding the non-structural protein NS5B and core protein, both of which provide non-overlapping sequence differences between the genotypes and subtypes (Bowden 2006).

## **Reverse hybridising assay (Versant<sup>®</sup> HCV Genotype 2.0 System (LiPA))**

In reverse hybridising, biotinylated cDNA clones from HCV RNA are produced by reverse transcriptase and then transferred and hybridised to immobilised oligonucleotides specific to different genotypes and subtypes. After removing unbound DNA by a washing step, the biotinylated DNA fragments can be detected by chemical linkage to coloured probes.

The Versant<sup>®</sup> HCV Genotype 2.0 System is suitable for identifying genotypes 1-6 and more than 15 different subtypes and is currently the preferentially used assay for HCV genotyping. By simultaneous analyses of the 5'UTR and core region, a high specificity is achieved especially to differentiate the genotype 1 subtypes. In a study evaluating the specificity of the Versant<sup>®</sup> HCV Genotype 2.0 System, 96.8% of all genotype 1 samples and 64.7% of all genotype samples were correctly subtyped. No misclassifications at the genotype level were observed. Difficulties in subtyping occurred in particular in genotypes 2 and 4. Importantly, none of the misclassifications would have had clinical consequences, which qualifies the Versant<sup>®</sup> HCV Genotype 2.0 System as highly suitable for clinical decision-making (Bouchardeau 2007).

## **Direct sequence analysis (Trugene<sup>®</sup> HCV 5'NC genotyping kit)**

The TruGene<sup>®</sup> assay determines the HCV genotype and subtype by direct analysis of the nucleotide sequence of the 5'UTR region. Incorrect genotyping rarely occurs with this assay. However, the accuracy of subtyping is poor because of the exclusive analyses of the 5'UTR (Pawlotsky 2003).

## **Real-time PCR technology (RealTime<sup>™</sup> HCV Genotype II assay)**

The current RealTime HCV Genotype II assay is based on real-time PCR technology, which is less time consuming than direct sequencing. Preliminary data revealed a 96% concordance at the genotype level and a 93% concordance on the genotype 1 subtype level when compared to direct sequencing of the NS5B and 5'UTR regions. Nevertheless, single genotype 2, 3, 4, and 6 isolates were misclassified at the genotype level, indicating a need for assay optimization (Ciotti 2010).

# **Implications for diagnosing and managing acute and chronic hepatitis C**

## **Diagnosing acute hepatitis C**

When acute hepatitis C is suspected, the presence of both anti-HCV antibodies and HCV RNA should be tested. For HCV RNA detection, sensitive qualitative techniques with a lower detection limit of 50 IU/ml or less are required, for example TMA, qualitative RT-PCR or the newly developed real-time PCR systems. Testing for anti-HCV alone is insufficient for the diagnosis of acute hepatitis C because HCV specific antibodies appear only weeks after viral transmission. In contrast,

measurable HCV RNA serum concentrations emerge within the first days after infection. However, HCV RNA may fluctuate during acute hepatitis C, making a second HCV RNA test necessary several weeks later in all negatively tested patients with a suspicion of acute hepatitis C. When HCV RNA is detected in seronegative patients, acute hepatitis C is very likely. When patients are positive for both anti-HCV antibodies and HCV RNA, it may be difficult to discriminate between acute and acutely exacerbated chronic hepatitis C. Anti-HCV IgM detection will not clarify because its presence is common in both situations.

## Diagnosing chronic hepatitis C

Chronic hepatitis C should be considered in every patient presenting with clinical, morphological or biological signs of chronic liver disease. When chronic hepatitis C is suspected, screening for HCV antibodies by 2nd or 3rd generation EIAs is adequate because their sensitivity is >99%. False-negative results may occur rarely in immunosuppressed patients (i.e., HIV) and in patients on dialysis. When anti-HCV antibodies are detected, the presence of HCV RNA has to be determined in order to discriminate between chronic hepatitis C and resolved HCV infection. The latter cannot be distinguished by HCV antibody tests from rarely occurring false-positive serological results, the exact incidence of which is unknown. Serological false-positive results can be identified by the additional performance of an immunoblot assay. Many years after disease resolution, anti-HCV antibodies may become undetectable via commercial assays in some patients.

## Diagnostic tests in the management of hepatitis C therapy

The current treatment recommendations for acute and chronic hepatitis C are based on HCV genotyping and on HCV RNA load determination before, during and after antiviral therapy. When HCV RNA has been detected, exact genotyping and HCV RNA load determination is necessary in every patient considered for antiviral therapy. Exact subtyping might gain increased importance during therapies with directly acting antiviral (DAA) agents because some subtypes behave differently regarding the development of resistance. Low HCV RNA concentration (<600,000–800,000 IU/ml) is a positive predictor of SVR. Genotyping is mandatory for the selection of the optimal treatment regimen and duration of therapy, since many DAA agents are selectively effective for only some HCV genotypes (Lange 2010), and since treatment durations generally can be shorter for patients infected with HCV genotypes 2 or 3 compared to patients infected with genotypes 1 or 4 (Manns 2006).

### Dual combination therapy (PEG-IFN + ribavirin)

For HCV genotype 1 (and 4) treatment can be shortened to 24 weeks in patients with low baseline viral load (<600,000–800,000 IU/ml) and rapid virologic response (RVR) with undetectable HCV RNA at week 4 of treatment. In slow responders with a 2 log<sub>10</sub> decline but still detectable HCV RNA levels at week 12 and undetectable HCV RNA at week 24, treatment should be extended to 72 weeks. In patients with complete early virologic response with undetectable HCV RNA at week 12 (cEVR), standard treatment is continued to 48 weeks. Genotypes 5 and 6 are treated the same as genotype 1 infected patients due to the lack of adequate clinical trials, whereas genotypes 2 and 3 generally allow treatment duration of 24 weeks, which may be shortened to 16 weeks (depending on RVR and [low] baseline

viral load) or extended to 36–48 weeks depending on the initial viral decline (Manns 2006, Layden-Almer 2006).

Independent of the HCV genotype, proof of HCV RNA decrease is necessary to identify patients with little chance of achieving SVR. HCV RNA needs to be quantified before and 12 weeks after treatment initiation and antiviral therapy should be discontinued if a decrease of less than 2 log<sub>10</sub> HCV RNA levels is observed (negative predictive value 88–100%). In a second step, HCV RNA should be tested with highly sensitive assays after 24 weeks of treatment because patients with detectable HCV RNA at this time point only have a 1–2% chance of achieving SVR.

### **Triple therapy (telaprevir or boceprevir + peginterferon/ribavirin)**

Complex treatment algorithms have been introduced with the approval of triple-therapies that now include a HCV NS3 protease inhibitor for chronic HCV genotype 1 infection. These algorithms are different for treatment with telaprevir or boceprevir.

Shortening of treatment duration with boceprevir triple therapy to 28 weeks is possible in treatment-naïve patients who achieve an extended rapid virologic response (eRVR) defined by undetectable HCV RNA levels at weeks 8 and 24 of treatment. Stopping rules are based on detectable HCV RNA concentrations above 100 IU/ml at week 12 or detectable HCV RNA by a sensitive assay at week 24.

For telaprevir triple therapy, shortening of treatment duration to 24 weeks in treatment-naïve and relapser patients is based on undetectable HCV RNA at weeks 4 and 12 of treatment. Stopping rules include detectable HCV RNA >1000 IU/ml at week 4 or 12 and detectable HCV RNA at week 24.

Measurement of HCV RNA at additional time points during boceprevir- or telaprevir-based triple therapies is recommended to identify viral breakthrough due to the emergence of HCV variants resistant to DAA agents.

SVR, defined as the absence of detectable HCV RNA 24 weeks after treatment completion, should be assessed by an HCV RNA detection assay with a lower limit of 50 IU/ml or less to evaluate long-lasting treatment success.

Due to the differences in HCV RNA concentrations of up to a factor of 4 between the different commercially available assays, despite standardisation of the results to IU, and due to intra- and interassay variability of up to a factor of 2, it is recommended to always use the same assay in a given patient before, during and after treatment and to repeat HCV RNA measurements at baseline in cases with HCV RNA concentrations between 400,000 and 1,000,000 IU/ml. Furthermore, the new stopping rules for boceprevir and telaprevir triple therapies based on viral cut-offs of 100 and 1000 IU/ml respectively, were assessed by the Cobas® TaqMan® assay and no comparative data with other HCV RNA assays are available yet.

## **References**

- Bouchardeau F, Cantaloube JF, Chevaliez S, et al. Improvement of hepatitis C virus (HCV) genotype determination with the new version of the INNO-LiPA assay. *J Clin Microbiol* 2007;45:1140-5. ([Abstract](#))
- Bowden DS, Berzsenyi MD. Chronic hepatitis C virus infection: genotyping and its clinical role. *Future Microbiol* 2006;1:103-12. ([Abstract](#))
- Chevaliez S, Bouvier-Alias M, Brillet R, Pawlotsky JM. Overestimation and underestimation of hepatitis C virus RNA levels in a widely used real-time polymerase chain reaction-based method. *Hepatology* 2007;46:22-31. ([Abstract](#))

## 200 Hepatology 2012

- Ciotti M, Marcuccilli F, Guenci T, et al. A multicenter evaluation of the Abbott RealTime HCV Genotype II assay. *J Virol Methods* 2010;167:205-7. ([Abstract](#))
- Colin C, Lanoir D, Touzet S, Meyaud-Kraemer L, Bailly F, Trepo C. Sensitivity and specificity of third-generation hepatitis C virus antibody detection assays: an analysis of the literature. *J Viral Hepat* 2001;8:87-95. ([Abstract](#))
- Colucci G, Ferguson J, Harkleroad C, et al. Improved COBAS TaqMan hepatitis C virus test (Version 2.0) for use with the High Pure system: enhanced genotype inclusivity and performance characteristics in a multisite study. *J Clin Microbiol* 2007;45:3595-600.
- Deuffic-Burban S, Deltenre P, Buti M, Stroffolini T, J. P. HCV burden in Europe: impact of national treatment practices on future HCV-related morbidity and mortality through a modeling approach. *Hepatology* 2010;52:678.
- Hendricks DA, Friesenhahn M, Tanimoto L, Goergen B, Dodge D, Comanor L. Multicenter evaluation of the VERSANT HCV RNA qualitative assay for detection of hepatitis C virus RNA. *J Clin Microbiol* 2003;41:651-6. ([Abstract](#))
- Hofmann WP, Dries V, Herrmann E, Gartner B, Zeuzem S, Sarrazin C. Comparison of transcription mediated amplification (TMA) and reverse transcription polymerase chain reaction (RT-PCR) for detection of hepatitis C virus RNA in liver tissue. *J Clin Virol* 2005;32:289-93.
- Konnick EQ, Erali M, Ashwood ER, Hillyard DR. Performance characteristics of the COBAS Amplicor Hepatitis C Virus (HCV) Monitor, Version 2.0, International Unit assay and the National Genetics Institute HCV Superquant assay. *J Clin Microbiol* 2002;40:768-73. ([Abstract](#))
- Lange CM, Sarrazin C, Zeuzem S. Review article: specifically targeted antiviral therapy for hepatitis C - a new era in therapy. *Aliment Pharmacol Ther* 2010;32:14-28. ([Abstract](#))
- Layden-Almer JE, Cotler SJ, Layden TJ. Viral kinetics in the treatment of chronic hepatitis C. *J Viral Hepat* 2006;13:499-504. ([Abstract](#))
- Lee SC, Antony A, Lee N, et al. Improved version 2.0 qualitative and quantitative AMPLICOR reverse transcription-PCR tests for hepatitis C virus RNA: calibration to international units, enhanced genotype reactivity, and performance characteristics. *J Clin Microbiol* 2000;38:4171-9. ([Abstract](#))
- Manns MP, Wedemeyer H, Cornberg M. Treating viral hepatitis C: efficacy, side effects, and complications. *Gut* 2006;55:1350-9. ([Abstract](#))
- McHutchison JG. Understanding hepatitis C. *Am J Manag Care* 2004;10:S21-9. ([Abstract](#))
- Mederacke I, Wedemeyer H, Ciesek S, et al. Performance and clinical utility of a novel fully automated quantitative HCV-core antigen assay. *J Clin Virol* 2009;46:210-5. ([Abstract](#))
- Medici MC, Furlini G, Rodella A, et al. Hepatitis C virus core antigen: analytical performances, correlation with viremia and potential applications of a quantitative, automated immunoassay. *J Clin Virol* 2011;51:264-9. ([Abstract](#))
- Michelin BD, Muller Z, Stelzl E, Marth E, Kessler HH. Evaluation of the Abbott RealTime HCV assay for quantitative detection of hepatitis C virus RNA. *J Clin Virol* 2007;38:96-100. ([Abstract](#))
- Morishima C, Chung M, Ng KW, Brambilla DJ, Gretch DR. Strengths and limitations of commercial tests for hepatitis C virus RNA quantification. *J Clin Microbiol* 2004;42:421-5. ([Abstract](#))
- Nolte FS, Fried MW, Shiffman ML, et al. Prospective multicenter clinical evaluation of AMPLICOR and COBAS AMPLICOR hepatitis C virus tests. *J Clin Microbiol* 2001;39:4005-12. ([Abstract](#))
- Pawlotsky JM, Martinot-Peignoux M, Poveda JD, et al. Quantification of hepatitis C virus RNA in serum by branched DNA-based signal amplification assays. *J Virol Methods* 1999;79:227-35. ([Abstract](#))
- Pawlotsky JM. Diagnostic testing in hepatitis C virus infection: viral kinetics and genomics. *Semin Liver Dis* 2003;23 Suppl 1:3-11. ([Abstract](#))
- Pawlotsky JM. Use and interpretation of hepatitis C virus diagnostic assays. *Clin Liver Dis* 2003;7:127-37. ([Abstract](#))
- Sabato MF, Shiffman ML, Langley MR, Wilkinson DS, Ferreira-Gonzalez A. Comparison of performance characteristics of three real-time reverse transcription-PCR test systems for detection and quantification of hepatitis C virus. *J Clin Microbiol* 2007;45:2529-36. ([Abstract](#))



- Sarrazin C, Gartner BC, Sizmann D, et al. Comparison of conventional PCR with real-time PCR and branched DNA-based assays for hepatitis C virus RNA quantification and clinical significance for genotypes 1 to 5. *J Clin Microbiol* 2006;44:729-37. ([Abstract](#))
- Sarrazin C, Hendricks DA, Sedarati F, Zeuzem S. Assessment, by transcription-mediated amplification, of virologic response in patients with chronic hepatitis C virus treated with peginterferon alpha-2a. *J Clin Microbiol* 2001;39:2850-5. ([Abstract](#))
- Sarrazin C, Teuber G, Kokka R, Rabenau H, Zeuzem S. Detection of residual hepatitis C virus RNA by transcription-mediated amplification in patients with complete virologic response according to polymerase chain reaction-based assays. *Hepatology* 2000;32:818-23. ([Abstract](#))
- Sarrazin C. Highly sensitive hepatitis C virus RNA detection methods: molecular backgrounds and clinical significance. *J Clin Virol* 2002;25 Suppl 3:S23-9. ([Abstract](#))
- Schutten M, Fries E, Burghoorn-Maas C, Niesters HG. Evaluation of the analytical performance of the new Abbott RealTime RT-PCRs for the quantitative detection of HCV and HIV-1 RNA. *J Clin Virol* 2007;40:99-104. ([Abstract](#))
- Scott JD, Gretch DR. Molecular diagnostics of hepatitis C virus infection: a systematic review. *Jama* 2007;297:724-32. ([Abstract](#))
- Simmonds P, Bukh J, Combet C, et al. Consensus proposals for a unified system of nomenclature of hepatitis C virus genotypes. *Hepatology* 2005;42:962-73. ([Abstract](#))
- Terrault NA, Pawlotsky JM, McHutchison J, et al. Clinical utility of viral load measurements in individuals with chronic hepatitis C infection on antiviral therapy. *J Viral Hepat* 2005;12:465-72. ([Abstract](#))
- Vehrmeren J, Kau A, Gärtner B, Göbel R, Zeuzem S, Sarrazin C. Differences between two real-time PCR based assays (Abbott RealTime HCV, COBAS AmpliPrep/COBAS TaqMan) and one signal amplification assay (VERSANT HCV RNA 3.0) for HCV RNA detection and quantification. *J Clin Virol* 2008;52:133-7.
- Veillon P, Payan C, Picchio G, Maniez-Montreuil M, Guntz P, Lunel F. Comparative evaluation of the total hepatitis C virus core antigen, branched DNA, and amplicor monitor assays in determining viremia for patients with chronic hepatitis C during interferon plus ribavirin combination therapy. *J Clin Microbiol* 2003;41:3121-30. ([Abstract](#))
- Vermehren J, Colluci G, Gohl P, et al. Development of a second version of the Cobas AmpliPrep/Cobas TaqMan hepatitis C virus quantitative test with improved genotype inclusivity. *J Clin Microbiol* 2011;49:3309-15. ([Abstract](#))
- Vermehren J, Yu ML, Monto A, et al. Multi-center evaluation of the Abbott RealTime HCV Assay for monitoring patients undergoing antiviral therapy for chronic hepatitis C. *J Clin Virol* 2011;52:133-7. ([Abstract](#))

## 13. Standard Therapy of Chronic Hepatitis C Virus Infection

*Markus Cornberg, Svenja Hardtke, Kerstin Port, Michael P. Manns, Heiner Wedemeyer*

### Goal of antiviral therapy

Globally, there are approximately 130-170 million people chronically infected with hepatitis C virus (HCV), in Europe 8-11 million (Cornberg 2011, Shepard 2005). Despite the implementation of blood-donor screening in the early '90s, there is still an anticipated increase of HCV-related cirrhosis, hepatic decompensation, and hepatocellular carcinoma (HCC) over the course of the next decade (Davis 2010). The goal of antiviral therapy is to cure hepatitis C via a sustained elimination of the virus (2011). A sustained elimination of HCV is achieved if the HCV RNA remains negative six months after the end of treatment (sustained virological response, SVR) (Table 1). Follow-up studies document that more than 99% of patients who achieve an SVR remain HCV RNA negative 4-5 years after the end of treatment and no signs of hepatitis have been documented (Manns 2008, Swain 2010). Importantly, long-term benefits of SVR are the reduction of HCV-related hepatocellular carcinoma and overall mortality (Backus 2011, Veldt 2007). In 2011, the FDA accepted SVR-12 as endpoint for future trials because HCV relapse usually occurs within the first 12 weeks after the end of treatment.

In addition to liver disease, several extra hepatic manifestations, such as cryoglobulinemia, non-Hodgkin lymphoma, membranoproliferative glomerulonephritis or porphyria cutanea tarda have been reported in the natural history of hepatitis C virus infection (HCV). Antiviral treatment may improve symptoms even without achieving an SVR. On the other hand, antiviral therapy may worsen extrahepatic manifestations (Pischke 2008, Zignego 2007).

### Basic therapeutic concepts and medication

Before the identification of HCV as the infectious agent for non-A, non-B hepatitis (Choo 1989), interferon  $\alpha$  (IFN) led to a normalisation of transaminases and an improvement of liver histology in some patients (Hoofnagle 1986). After the identification of HCV it became possible to measure success of therapy as a long-

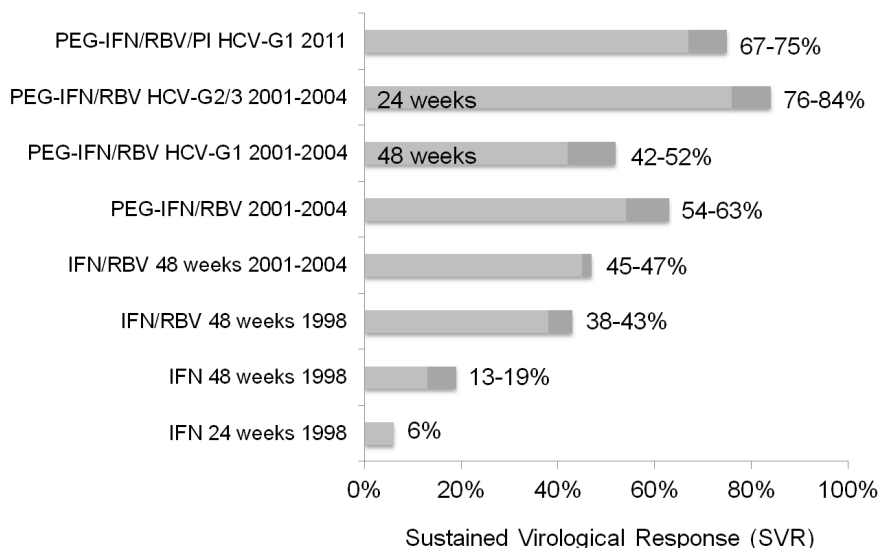
lasting disappearance of HCV RNA from serum, the SVR. Since then, SVR rates have increased from 5-20% with IFN monotherapy up to 40-50% with the combination of IFN + ribavirin (RBV) (McHutchison 1998, Poynard 1998). Different HCV genotypes (HCV G) show different SVR rates. Patients with the most frequent HCV G1 require a longer treatment duration and still get a lower SVR compared to HCV G2 and HCV G3 (Figure 1). The development of pegylated interferon  $\alpha$  (PEG-IFN) improved the pharmacokinetics of IFN, allowing more convenient dosing intervals and resulting in higher SVR, especially for HCV G1. Two PEG-IFNs are available; PEG-IFN  $\alpha$ -2b (PEG-Intron<sup>®</sup>, Merck) and PEG-IFN  $\alpha$ -2a (PEGASYS<sup>®</sup>, Roche). Although smaller trials from southern Europe have suggested slightly higher SVR rates in patients treated with PEG-IFN  $\alpha$ -2a (Ascione 2010, Rumi 2010), a large US multicentre study did not detect any significant difference between the two PEG-IFNs + RBV regarding SVR (McHutchison 2009b).

The two PEG-IFNs do have different pharmacokinetic profiles due to their different polyethylene glycol moieties. PEG-IFN  $\alpha$ -2b is bound to a single linear 12-kDa polyethylene glycol molecule, whereas PEG-IFN  $\alpha$ -2a is covalently attached to a 40-kDa branched chain polyethylene glycol moiety. The distinct sizes of the PEG-IFN influence the volume of distribution. PEG-IFN  $\alpha$ -2b is dosed according to body weight (1.5  $\mu$ g/kg once weekly), while the larger PEG-IFN  $\alpha$ -2a is given in a fixed dose of 180  $\mu$ g once weekly (reviewed in (Cornberg 2002)) (Table 2). PEG-IFN  $\alpha$ -2b may also be dosed at 1.0  $\mu$ g/kg once patients become negative for HCV RNA without major declines in SVR rates (Manns 2011a, McHutchison 2009b). RBV should be administered according to the bodyweight of the patient. A retrospective analysis of the large PEG-IFN  $\alpha$ -2b + RBV pivotal trial revealed that the optimal dose of RBV (Rebetol<sup>®</sup>, Merck) is at least 11 mg/kg (Manns 2001). A prospective, multicentre, open-label, investigator-initiated study confirmed that PEG-IFN  $\alpha$ -2b plus weight-based RBV is more effective than flat-dose ribavirin, particularly in HCV G1 patients (Jacobson 2007). A RBV dose of 15 mg/kg would be ideal, although higher doses are associated with higher rates of anemia (Snoeck 2006). When combined with PEG-IFN  $\alpha$ -2a, a RBV dose of 1000 mg if <75 kg or 1200 mg if  $\geq$ 75 kg is recommended for HCV G1 patients while a flat dose of 800 mg RBV was initially suggested for patients with HCV G2 and 3 (Hadziyannis 2004). However, a weight-based dose of ribavirin (12-15 mg/kg) may be preferred, especially in difficult to treat patients and in Response-guided Therapy (RGT) treatment approaches (EASL 2011, Sarrazin 2010). In 2011, the first direct antiviral agents (DAA) were approved for patients with HCV G1. Two inhibitors of the HCV protease (PI), boceprevir (Victrelis<sup>®</sup>, Merck) and telaprevir (Incivek<sup>®</sup>, Vertex; Incivo<sup>®</sup>, Johnson & Johnson), improve SVR rates up to 75% in naïve HCV G1 patients (Jacobson 2011b, Poordad 2011b) and 29-88% in treatment experienced HCV G1 (Bacon 2011, Zeuzem 2011). However, both PIs require combination with PEG-IFN + RBV because monotherapy would result in rapid emergence of drug resistance. Both boceprevir (BOC) and telaprevir (TLV) can be combined with PEG-IFN  $\alpha$ -2a or PEG-IFN  $\alpha$ -2b.

**Table 1. Relevant definitions for HCV treatment.**

Abbreviation	Term	Description
SVR	Sustained Virological Response	HCV RNA negative 6 months after the end of therapy
SVR-12	Sustained Virological Response	HCV RNA negative 12 weeks after the end of therapy; FDA-accepted endpoint for future trials
RVR	Rapid Virological Response	HCV RNA negative after 4 weeks of therapy
eRVR (BOC)	Extended Rapid Virological Response (for boceprevir)	HCV RNA negative (LLD not LLQ) between week 8 and week 24 of BOC therapy: RGT criterion for BOC
eRVR (TLV)	Extended Rapid Virological Response (for telaprevir)	HCV RNA negative (LLD not LLQ) between week 4 and week 12 of TLV therapy: RGT criterion for TLV
EVR	Early Virological Response	HCV RNA decline $\geq 2 \log_{10}$ at week 12
cEVR	Complete Early Virological Response	HCV RNA negative at week 12
NR (BOC)	Nonresponse (boceprevir)	HCV RNA $\geq 100$ IU/mL at week 12; or HCV RNA positive at week 24; futility rule for BOC
NR (TLV)	Nonresponse (telaprevir)	HCV RNA $\geq 1000$ IU/mL at week 4 or week 12; or HCV RNA positive at week 12: Futility rule for TLV
BT	Breakthrough	HCV RNA was LLD but increased to $\geq 100$ IU/mL or increase of HCV RNA $\geq 1 \log_{10}$ during therapy
RL	Relapse	HCV RNA negative at EOT and recurrence of HCV RNA during the follow-up of 6 months.
PR	Partial Response	HCV RNA decline $\geq 2 \log_{10}$ at week 12 but positive at week 24 during PEG-IFN/RBV
NULR	Null response	HCV RNA decline $< 2 \log_{10}$ at week 12 during PEG-IFN/RBV
LI	Lead-In	4 weeks PEG-IFN/RBV before adding a PI

LLD, lower limit of detection ( $< 10$ - $15$  IU/mL; here indicated as negative); LLQ, lower limit of quantification; EOT, end of treatment; RGT, response-guided therapy



IFN trials	PEG-IFN trials	PI trials
USA trial: McHutchison et al., NEJM 1998 Int. trial: Poynard et al., Lancet 1998	PEG-IFN2b: Manns et al., Lancet et al., 2001 PEG-IFN2a: Friedet et al., NEJM 2002 PEG-IFN2a: Hadziyannis et al., Ann Int Med. 2004	Boceprevir: Poordad et al., NEJM 2011 (non-black cohort) Telaprevir: Jacobson et al., NEJM 2011

**Figure 1. Development of chronic hepatitis C therapy.** The sustained virologic response rates have improved from around 5% with interferon monotherapy in the early 90s to >70% today with triple therapy of PEG-IFN + ribavirin + PI.

**Table 2. Approved drugs for the treatment of chronic hepatitis C (2011).**

Medication	Dosing
Type I interferons	Subcutaneous injection
Pegylated Interferon $\alpha$ -2a (Pegasys®)	180 $\mu$ g once weekly
Pegylated Interferon $\alpha$ -2b (PEG-Intron®)	1.5 $\mu$ g/kg once weekly
Interferon $\alpha$ -2a (Roferon®)	3 - 4.5 Mill I.U. three times weekly
Interferon $\alpha$ -2b (Intron A®)	3 Mill I.U. three times weekly
Consensus Interferon (Infergen®)	9 $\mu$ g three times weekly
Ribavirin	Oral tablets or capsules
Ribavirin (Copegus®)	800 - 1200 mg daily (200 mg or 400 mg tablets)
Ribavirin (Rebetol®)	600 - 1400 mg daily (200 mg capsules or solution)
HCV protease inhibitors	Oral tablets or capsules
Boceprevir (Victrelis®)	800 mg (4 x 200 mg capsules) every 7-9 hours
Telaprevir (Incivek®, Incivo®)	750 mg (2 x 375 mg tablets) every 7-9 hours

## Predictors of treatment response

During the last decade, tailoring treatment duration and dosing according to individual parameters associated with response have improved SVR. Predicting SVR before the start of antiviral treatment helps in making treatment decisions. Important baseline factors associated with SVR to PEG-IFN/RBV are the HCV genotype, the degree of liver fibrosis and steatosis, baseline viral load, presence of insulin resistance, age, gender, body mass index, ethnicity, and HIV co-infection (Berg 2011, [McHutchison 2009b](#)). Many of these factors may have less relevance for triple therapy, i.e., insulin resistance seems not to impact SVR to PEG-IFN/RBV/PI (Berg 2011, Serfaty 2010) whereas low-density lipoprotein (LDL) was associated with SVR (at least for TLV) (Berg 2011).

On the other hand, new parameters seem to be more important such as HCV subtype 1a and 1b. Patients with HCV G1a have a higher risk of developing resistance during PI-based therapy compared to HCV G1b because HCV G1a requires an exchange of only one nucleotide versus two for HCV G1b in position 155 to develop resistance (reviewed in [Sarrazin and Zeuzem 2010b](#)).

During treatment, the kinetics of the HCV RNA decline is a strong predictor of response. HCV RNA measurements at week 4, 12 and 24 are important for a response-guided treatment approach for PEG-IFN/RBV but also for the new triple therapy including BOC and TLV. Definitions of response and futility rules are summarized in Table 1. (Futility rules means that if at these time points, the viral load threshold is exceeded or detected in serum, therapy should be stopped.)

Recently, genome-wide association studies have identified host genetic polymorphisms (i.e., rs12979860, rs8099917) located on chromosome 19 located upstream to the region coding for IL28B (or IFN  $\lambda$ 3) associated with SVR to treatment with PEG-IFN/RBV in HCV G1 patients ([Ge 2009](#), [Rauch 2010](#), [Suppiah 2009](#), [Tanaka 2009](#)) but also to a lesser extent for HCV G2/3 ([Mangia 2010c](#), [Sarrazin 2011b](#)). Data on IL28B explain the different responses to PEG-IFN/RBV between different ethnic groups, i.e., low SVR in African Americans and high SVR in Asian patients. However, the negative predictive value is not strong enough to recommend general testing ([EASL 2011](#)). Viral kinetics, especially response at week 4, have a higher predictive value ([Sarrazin 2011a](#)) and the relevance of IL28B as a predictive marker for the success of triple therapy with PEG-IFN/RBV/PI is less significant ([Jacobson 2011a](#), [Pol 2011a](#), [Poordad 2011a](#)). However, IL28B testing may be useful to determine the IFN responsiveness and the likelihood of achieving RVR with PEG-IFN/RBV before starting triple therapy. It may be of relevance to discuss treatment options with the individual patient (see below). Additional predictive markers are being evaluated. For example, low serum levels of interferon  $\gamma$  inducible protein 10 (IP 10) are associated with SVR and may improve the predictive value for discrimination between SVR and nonresponse ([Darling 2011](#), [Fattovich 2011](#)).

## Antiviral resistance

The development of direct antiviral agents leads to the emerging problem of drug resistance due to so-called resistant-associated amino acid variants (RAVs) of the virus. Patients who received monotherapy with BOC or TLV develop resistance

within a few days (Sarrazin 2007). RAVs associated with resistance to BOC and TLV are listed in Table 3. Due to their overlapping resistance profiles, one PI cannot substitute the other in the case of viral breakthrough. Also, a combination of the two PIs is not rationale. As mentioned above, combination with PEG-IFN/RBV is mandatory for the usage of BOC or TLV and RAVs to BOC and TLV have not been associated with less sensitivity to PEG-IFN/RBV (Kieffer 2007). Importantly, if patients have a decreased PEG-IFN/RBV response, the risk of developing significant RAVs is higher. Measures for the prevention of drug resistance are adherence to the dose of the medications (most importantly to the PI) and compliance with the futility rules (see below). If RAVs emerge, it is not completely known for how long they persist and if this has any significant consequences for future therapies. Some studies suggest that the majority of resistant variants revert to wild type 1-2 years after the end of therapy (Sarrazin 2007, Sherman 2011b). At this stage there is no rationale to routinely analyse HCV sequences either before therapy or during treatment because it has no practical consequence. Dominant RAVs before treatment have been documented (Kuntzen 2008) but the influence of treatment response is not well characterised.

**Table 3. Resistant-associated amino acid variants of HCV NS3 protease to boceprevir and telaprevir (adapted from Sarrazin 2012).**

	V36A /M	T54S /A	V55A	Q80R /K	R155K /T/Q	A156S	A156T /V	D168A /E/G/H /T/Y	V170A /T
BOC	X	X	X		X	X	X		X
TLV	X	X			X	X	X		

## Treatment of HCV genotype 1

### Treatment of naïve patients

Untreated patients with HCV genotype 1 (HCV G1) have various treatment options. Triple therapy with PEG-IFN+RBV+PI increases the overall SVR by 25-31% (Table 4). Many patients qualify for response-guided therapy (RGT) based on viral kinetics. In 44-65% of patients with eRVR treatment duration can be reduced to 24-28 weeks (Figures 2A, 2B), some 4-6 times more than with PEG-IFN/RBV. However, in patients with favourable predictors for SVR (low baseline HCV RNA, IL28CC, no advanced fibrosis), dual therapy with PEG-IFN/RBV may still be an option. In those patients, a lead-in of 4 weeks PEG-IFN/RBV can identify patients with RVR who achieve high SVR without adding a PI. Patients with low viral load at baseline who achieve RVR have demonstrated 78-100% SVR with 24 weeks PEG-IFN/RBV dual therapy alone (Berg 2009, Ferenci 2008, Jensen 2006, Sarrazin 2011a, Zeuzem 2006) (Table 5). Not adding BOC or TLV will reduce costs and adverse events, two factors that can lead to treatment discontinuation. The number of patients who qualify for dual therapy may vary depending on the distribution of IL28B polymorphisms. On the other hand, a lead-in therapy may identify patients with a poor response to IFN with a high chance of developing resistance. Only 29-31% of patients who have  $<1 \log_{10}$  reduction of HCV RNA after 4 weeks PEG-IFN/RBV go on to achieve SVR when they add BOC. Other negative predictors

(HCV G1a, cirrhosis) together with the lead-in concept may increase the negative predictive value of achieving SVR. In that case a wait-and-see strategy may be considered. The 4-week lead-in strategy also proved useful in assessing compliance, tolerability and safety before initiating the PI. The lead-in concept was developed in the BOC studies with the hypothesis of reducing resistance and improving SVR (Kwo 2010). However, the lead-in phase seems to have no significant effect on the SVR or on the development of antiviral resistance (Kwo 2010, Zeuzem 2011). Lead-in has also been evaluated for TLV but only in treatment-experienced patients (Zeuzem 2011). It is recommended to discuss the lead-in option and the consequences with the patient before initiation of treatment.

**Table 4. Phase III studies with BOC or TLV treatment regimens in treatment naïve patients with HCV genotype 1.** Studies are no head-to-head studies and SVR between different studies are difficult to compare because they had significant differences in genetic and socioeconomic backgrounds.

Study	Dosing	eRVR, SVR
SPRINT-2 (Poordad 2011b) N=938 nonblack (NB) N=159 black *28 weeks if eRVR BOC	a) 1.5 µg/kg PEG-IFN α-2b, 600-1400 mg RBV 48 weeks 44 weeks Placebo (wk 4-48)	a) eRVR: 40/363 (11%) / NB: 12% SVR: 137/363 (38%) / NB: 40%
	b) 1.5 µg/kg PEG-IFN α-2b, 600-1400 mg RBV 28*-48 weeks 24 weeks 800 mg tid BOC (wk 4-28)	b) eRVR: 156/368 (42%) / NB: 45% SVR: 233/368 (63%) / NB: 67%
	c) 1.5 µg/kg PEG-IFN α-2b, 600-1400 mg RBV 48 weeks 44 weeks 800 mg tid BOC (wk 4-48)	c) eRVR: 155/366 (42%) / NB: 44% SVR: 242/366 (66%) / NB: 68%
ADVANCE (Jacobson 2011b) N=1088 *24 weeks if eRVR TLV	a) 180 µg PEG-IFN α-2a, 1000-1200 mg RBV 24*-48 weeks, 12 weeks 750 mg tid TLV (wk 0-12) (T12PR)	a) eRVR: 210/363 (58%) SVR: 271/363 (75%)**
	b) 180 µg PEG-IFN α-2a, 1000-1200 mg RBV 24*-48 weeks, 8 weeks 750 mg tid TLV, 4 weeks Placebo (wk 0-12)	b) eRVR: 207/363 (57%) SVR: 250/364 (69%)
	c) 180 µg PEG-IFN α-2a, 1000-1200 mg RBV 48 weeks, 12 weeks Placebo (wk 0-12)	c) SVR: 158/361 (44%)
ILLUMINATE (Sherman 2011a) N=540 N=352 (65%) eRVR N=322 randomised	a) eRVR: 180 µg PEG-IFN α-2a, 1000-1200 mg RBV 24 weeks, 12 weeks 750 mg tid TLV (wk 0-12)	a) SVR: 149/162 (92%)
	b) eRVR: 180 µg PEG-IFN α-2a, 1000-1200 mg RBV 48 weeks, 12 weeks 750 mg tid TLV (wk 0-12)	b) SVR: 140/160 (88%)
	c) no eRVR: 180 µg PEG-IFN α-2a, 1000-1200 mg RBV 48 weeks, 12 weeks 750 mg tid TLV (wk 0-12)	c) SVR: 76/118 (64%)

\*\* numbers from the published data are different from the numbers accepted by the FDA, i.e. 79% SVR for telaprevir 12 weeks, PEG-IFN/RBV

### Treatment regimens with boceprevir

Boceprevir (BOC) is a linear peptidomimetic ketoamide serine protease inhibitor that binds reversibly to the HCV nonstructural 3 (NS3) active site. BOC results in a significant decline of HCV RNA but given as monotherapy it leads to rapid emergence of viral resistance (Sarrazin and Zeuzem 2010b). Thus, combination with PEG-IFN/RBV is still necessary (Mederacke 2009). 800 mg BOC is given as 200 mg capsules every 7-9 hours together with food in combination with the optimal dose of PEG-IFN/RBV (Table 2). In all Phase III trials BOC was added



after the 4-week lead-in period as described above. In SPRINT-2 (serine protease inhibitor therapy 2), the Phase III study with 1097 treatment-naïve HCV G1 patients, safety and efficacy of two regimens of BOC added to PEG-IFN  $\alpha$ -2b/RBV after a 4-week lead-in with PEG-IFN/RBV were compared to PEG-IFN/RBV/placebo (Table 4) for 44 weeks. The two groups receiving BOC were treated with an RGT concept or a fixed duration of BOC. Patients in the RGT group received 24 weeks triple combination after the lead-in period. Treatment with PEG-IFN/RBV was continued through week 48 only if the criteria for eRVR were not met (HCV RNA levels undetectable from week 8 through week 24). Patients in the fixed therapy duration group received PEG-IFN/RBV/BOC for 44 weeks following the 4-week lead-in phase. Based on published data for response rates being lower for African-American patients, black and non-black patients were analysed as two different pre-defined cohorts of the SPRINT-2 study. Overall, adding BOC to PEG-IFN/RBV could significantly improve SVR in previously untreated patients with HCV genotype 1 leading to approval in 2011 (FDA: May; EMA: July). Non-black patients achieved 27-28% higher SVR, black patients increased SVR by 19-30%.

**Table 5. High SVR in naïve patients with HCV genotype 1 and low baseline viral load treated with 24 weeks of PEG-IFN/RBV.**

Study	Treatment	Subgroups (fast responder)	Weeks	SVR
(Zeuzem 2006) N=235	1.5 µg/kg PEG-IFN $\alpha$ -2b 800-1400 mg ribavirin	<600,000 IU/ml TW0	24	50%
		<600,000 IU/ml TW0 & <29 IU/ml TW4 (RVR)	24	89%
(Berg 2009) N=433	1.5 µg/kg PEG-IFN $\alpha$ -2b 800-1400 mg ribavirin	<5.3 IU/ml TW4 (RVR)	18-24	80%
		<800,000 IU/ml TW0 & <5.3 IU/ml TW4 (RVR)	18-24	100%
(Sarrazin 2011a) N=398	1.5 µg/kg PEG-IFN $\alpha$ -2b 800-1400 mg ribavirin	<800,000 IU/ml TW0 & <5-10 IU/ml TW4 (RVR)	24	88%
(Jensen 2006) N=216	180 µg PEG-IFN $\alpha$ -2a or 800 mg or 1000-1200 mg ribavirin	<50 IU/ml TW4 (RVR)	24	89%
		>50 IU/ml TW4 (RVR)	24	19%
(Ferenci 2008) N=120	180 µg PEG-IFN $\alpha$ -2a or 1000-1200 mg ribavirin	<50 IU/ml TW4 (RVR)	24	74% ITT 79% PP

\* SVR, sustained viral response; RVR, rapid virologic response.

The responsiveness to PEG-IFN/RBV is very important for the success of treatment with BOC. This is emphasized by the fact that the HCV RNA decline at week 4 is highly predictive of SVR. Patients with more than 1 log<sub>10</sub> HCV RNA decrease after the 4-week lead-in phase demonstrated an SVR of about 80% if treated with BOC but only 28-38% responded if HCV RNA declined less than 1 log<sub>10</sub>. Thus, the lead-in phase can be valuable to predict the responsiveness to PEG-IFN/RBV for further individualization of therapy as discussed above (Figure 3). Importantly, the overall SVR rates between the RGT group and the fixed 48-week therapy group were comparable (Table 4). Patients achieving eRVR were eligible

for a 28-week total therapy duration and almost all patients (96%) went on to achieve SVR (Poordad 2011b). Of note, HCV RNA negative means below the limit of detection (LLD) and not below limit of quantification (LLQ). This is important because SVR is diminished in patients with LLQ at weeks 8-24 who were treated for a shorter duration (Harrington 2011).

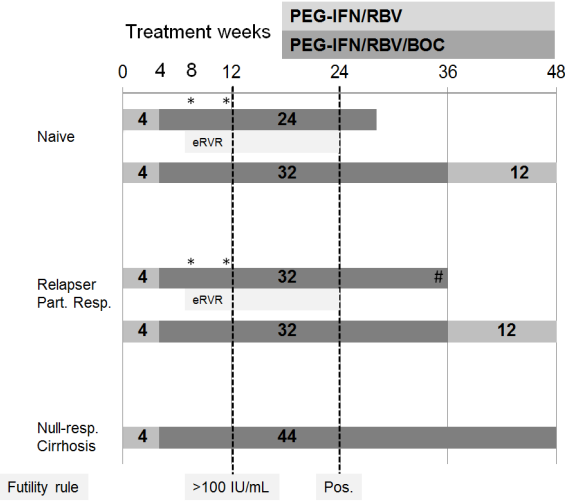
FDA and EMA have approved RGT for treatment naïve patients except for patients with liver cirrhosis (Figure 2A) but the accepted treatment duration for BOC-RGT is different to the study design of the Phase III study (32 vs 24 weeks BOC for patients without eRVR) (Figure 2A). In addition, a retrospective analysis led to the futility rule of HCV RNA >100 IU/mL at week 12. The predictive value for nonresponse was 100%. BOC was initially combined with PEG-IFN  $\alpha$ -2b. Recently, a study in therapy-experienced patients including relapsers and partial responders showed similar results with PEG-IFN  $\alpha$ -2a/RBV (Flamm 2011). Thus, both PEG-IFNs can be combined with BOC.

### Treatment regimens with telaprevir

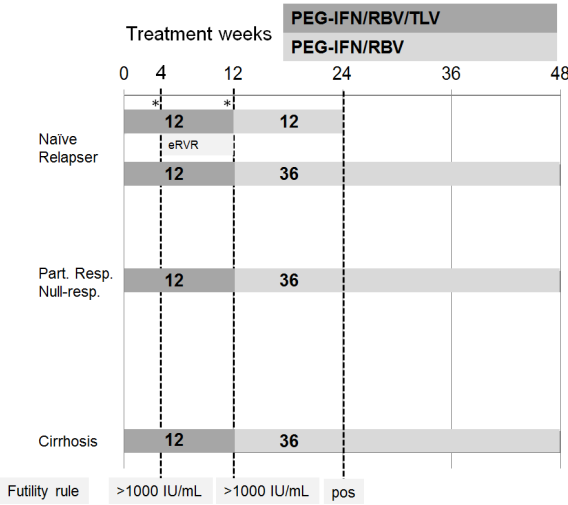
Telaprevir (TLV) is also an orally administered reversible, selective, peptidomimetic NS3/4A serine protease inhibitor, which leads to a significant decline of HCV RNA although viral resistance emerges rapidly if given as monotherapy (Sarrazin 2007). Thus, 750 mg TLV given as 375 mg tablets every 7-9 hours together with food (ideally >20 g fat) requires combination with optimal PEG-IFN/RBV. Telaprevir was administered for a maximum of 12 weeks in the Phase III trials; longer treatment duration is associated with increasing adverse events (McHutchison 2010). Two large Phase III studies (ADVANCE and ILLUMINATE) with a total of 1628 treatment-naïve HCV G1 patients showed that PEG-IFN/RBV/TLV significantly improved SVR compared to PEG-IFN/RBV and RGT is possible (Jacobson 2011b, Sherman 2011a). TLV was approved for the treatment of HCV G1 in 2011 (FDA: May; EMA: September). In the ADVANCE trial, 3 treatment groups were assessed for efficacy and safety using RGT in treatment-naïve patients (Jacobson 2011b). 12 weeks of TLV versus 8 weeks of TLV in combination with 24-48 weeks PEG-IFN/RBV were compared to 48 weeks PEG-IFN/RBV dual therapy. Patients who achieved eRVR qualified for 24 weeks of therapy (Table 4). SVR was significantly higher among those receiving TLV compared to the placebo group; 12 weeks TLV resulted in the highest SVR (Table 4). In all treatment groups, more than 80% of patients who achieved eRVR had SVR (89%, 83%, and 97%, respectively) (Jacobson 2011b).

To validate RGT, telaprevir 750 mg every 8 hours for 12 weeks was evaluated in an open-label study (ILLUMINATE trial) to prospectively assess 24 vs 48 weeks of treatment for HCV G1 patients who achieved eRVR. If HCV RNA levels were undetectable at weeks 4 and 12, patients were randomly assigned to continue with PEG-IFN/RBV for an additional 24 or 48 weeks. If eRVR was not attained, patients received PEG-IFN/RBV for up to 48 weeks. Of the 540 subjects, 389 (72%) achieved HCV RNA levels LLD at week 4 and 352 (65%) achieved eRVR. Patients who achieved eRVR and were randomized to the 24-week cohort experienced 92% SVR versus 88% who were treated for 48 weeks (Table 4) (Sherman 2011a). Importantly, patients with liver cirrhosis showed higher relapse rates with shorter treatment, therefore RGT for TLV has only been approved for naïve HCV G1 patients without liver cirrhosis. Also, retrospective analysis of the data showed that

early HCV RNA measurement at week 4 is predictive of nonresponse to TLV. Patients with HCV RNA values >1000 IU/mL after 4 weeks PEG-IFN/RBV/TLV did not achieve SVR. Therefore, therapy must be stopped.

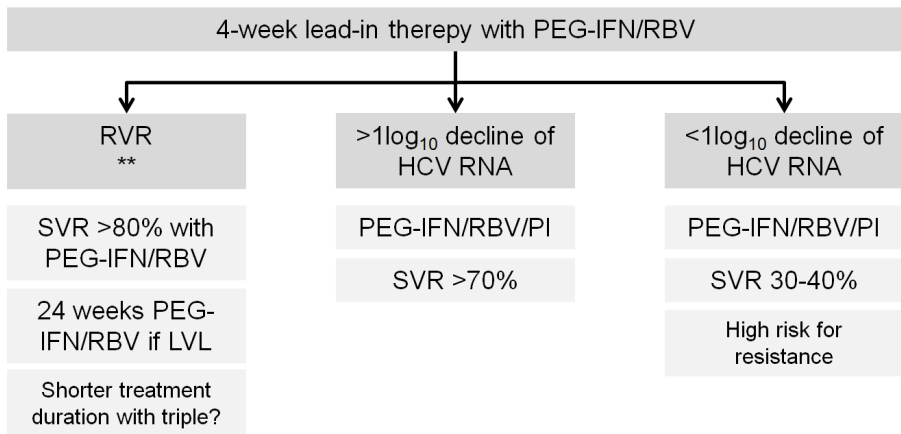


**Figure 2A. Treatment with BOC/PEG-IFN/RBV: Approved treatment algorithm for HCV G1 patients.** \*, RGT if eRVR (HCV RNA LLD week 8-24); #, EMA did not approve RGT for BOC regimens in previously treated patients.



**Figure 2B. Treatment with TLV/PEG-IFN/RBV: Approved treatment algorithm for HCV G1 patients.** \*RGT if eRVR (HCV RNA LLD week 4-12).

\*\*\* If patients have contraindications for BOC or TLV, dual therapy with PEG-IFN/RBV should be given for 24-72 weeks according to the HCV RNA decline at week 4 and week 12 (Sarrazin, Berg, Cornberg 2010 S3-Leitlinie). The treatment algorithm is similar to Figure 6.



**Figure 3. Suggestion to use the lead-in strategy for individualisation of treatment in patients with HCV genotype 1.** \*\*The number of patients with low baseline HCV RNA and RVR may vary between different countries due to IL28B differences.

## Treatment of patients with prior antiviral treatment failure

As more patients have been treated, the size of the population of patients who have failed to achieve SVR with PEG-IFN/RBV has expanded. Many nonresponder patients have advanced liver disease and successful treatment may extend life expectancy ([Backus 2011](#), [Veldt 2007](#)). Retreatment of patients with previous treatment failure is one of the most important current topics in the treatment of chronic hepatitis C.

### Definition of treatment failure

Definition of response to or failure on antiviral therapy is very important when considering retreating patients with chronic hepatitis C because the success of BOC- or TLV-based regimens depends on the IFN responsiveness. Patients may have been treated with different treatment regimens and compliance during the previous therapy was probably very varied. Most importantly, HCV RNA kinetics and the response profile during the previous therapy have to be taken into account before starting a new treatment. It is crucial to screen the patient's records and check treatment duration, drug dosing and HCV RNA of the previous therapy. Non-response is the failure of a patient to clear HCV RNA at any point during treatment. Definitions used for trials assessing novel therapy approaches have generally defined non-response as the failure to achieve EVR, which is  $\geq 2 \log_{10}$  reduction of HCV RNA after 12 weeks. Classifications of non-response include null response, partial response, relapse, and breakthrough (see Table 1, Figure 4).

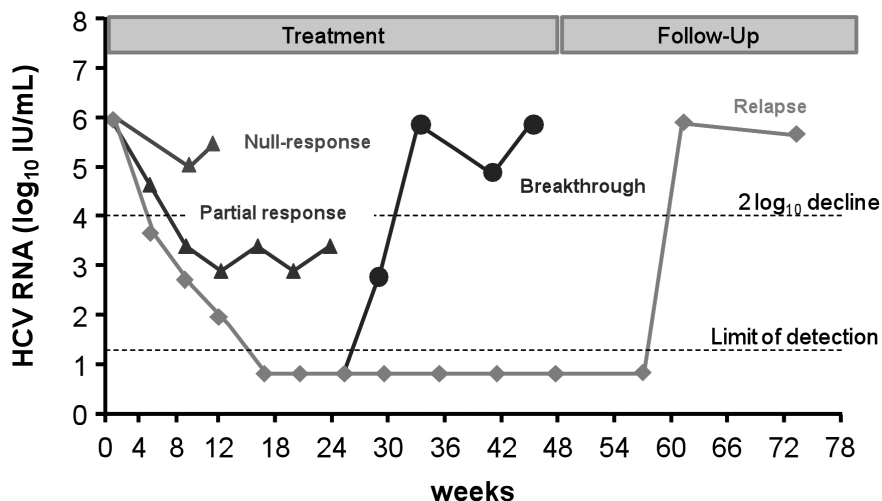


Figure 4. Different scenarios of treatment failure to antiviral therapy in chronic hepatitis C.

#### Retreatment of HCV G1 patients with relapse after PEG-IFN/RBV

Retreatment with PEG-IFN/RBV of relapse patients after IFN- or PEG-IFN-based combination therapy with ribavirin resulted in an SVR of 24-34% (Bacon 2011, Poynard 2009, Zeuzem 2011). Triple therapy with PEG-IFN/RBV/PI increases SVR dramatically to 69-88% (Bacon 2011, Zeuzem 2011) (Table 6). Relapse patients are the ideal patients for retreatment with a triple therapy regimen. Patients have already proven to respond to PEG-IFN and RBV. Thus, the backbone to prevent PI resistance is effective and a lead-in strategy may not be as important as in other situations. Although RGT was not evaluated in the Phase III REALIZE trial with TLV, a rollover study including relapse patients from Phase II studies has demonstrated that shorter treatment is effective in patients with eRVR (Muir 2011). Therefore, RGT is possible with BOC and TLV regimens (Figures 2A, 2B) if cirrhosis is excluded (Ghany 2011, Sarrazin 2012). In contrast, BOC RGT has only been approved by the FDA and not by the EMA because SVR was slightly lower in the RESPOND-2 RGT group (Table 6).

#### Retreatment of HCV G1 patients with partial response to PEG-IFN/RBV

Patients who are partial responders (PR) to standard PEG-IFN/RBV combination therapy have demonstrated SVRs ranging between 7% and 15% with a standard PEG-IFN/RBV retreatment (Bacon 2011, Zeuzem 2011). Retreatment with triple therapy increases SVR to 40%-59% (Bacon 2011, Zeuzem 2011) (Table 6). FDA but not EMA approved RGT for BOC (Figures 2A, 2B). Treatment duration for PEG-IFN/RBV/TLV is 48 weeks for all PR patients (Figure 2B). The 4-7-fold increase justifies retreatment. However, SVR decreases significantly in patients with cirrhosis (34% with TLV) and other negative response factors (Pol 2011b).

### Retreatment of HCV G1 patients with null response to PEG-IFN/RBV

Patients who are null responders (NULR) to standard PEG-IFN/RBV combination therapy have demonstrated SVRs ranging between 5% and 16% with an optimised PEG-IFN/RBV retreatment (Jensen 2009, Poynard 2009, [Zeuzem 2011](#)). Retreatment with PEG-IFN/RBV/PI did increase SVR more than 6-fold in the REALIZE trial ([Zeuzem 2011](#)). However, overall SVR with triple therapy is limited to 29-38% (Vierling 2011, [Zeuzem 2011](#)) (Table 6). If further negative predictive factors are present, SVR decreases to 27% in HCV G1a patients and to 14% in cirrhotic patients (not significantly different from PEG-IFN/RBV) (Figure 7A). This may justify the lead-in concept to decide if treatment with a PI is beneficial. Patients who do not achieve a 1 log<sub>10</sub> decline of HCV RNA after 4 weeks demonstrate only 15% SVR ([Zeuzem 2011](#)). Futility rules are the same for treatment-experienced patients as for treatment-naïve patients (Figures 2A, 2B).

**Table 6. Phase III studies with BOC or TLV treatment regimens in treatment-experienced patients infected with HCV genotype 1.** Studies are not head-to-head and SVR between studies are difficult to compare because they had significant differences in genetic and socioeconomic backgrounds.

Study	Dosing	SVR
RESPOND-2 ( <a href="#">Bacon 2011</a> ) n=403  *36 weeks if eRVR BOC	a) 1.5 µg/kg PEG-IFN α-2b, 600-1400 mg RBV 48 weeks 44 weeks Placebo (wk 4-48)	a) REL: 29% PR: 7%  All: 21%
	b) 1.5 µg/kg PEG-IFN α-2b, 600-1400 mg RBV <u>36*-48 weeks</u> <u>32 weeks 800 mg tid BOC</u> (wk 4-36)	b) REL: 69% PR: 40%  All: 59%
	c) 1.5 µg/kg PEG-IFN α-2b, 600-1400 mg RBV 48 weeks 44 weeks 800 mg tid BOC (wk 4-48)	c) REL: 75% PR: 52%  All: 66%
(Flamm 2011) n=201	a) 180 µg PEG-IFN α-2a, 1000-1200 mg RBV 48 weeks 44 weeks Placebo (wk 4-48)	a) REL, PR: 21%
	b) 180 µg PEG-IFN α-2a, 1000-1200 mg RBV 48 weeks 44 weeks 800 mg tid BOC (wk 4-48)	b) REL, PR: 64%
PROVIDE (Vierling 2011) n=48 (42 available)	1.5 µg/kg PEG-IFN α-2b, 600-1400 mg RBV 48 weeks 44 weeks 800 mg tid BOC (wk 4-48)	38% (16/42)
REALIZE ( <a href="#">Zeuzem 2011</a> ) n=663	a) 180 µg PEG-IFN α-2a, 1000-1200 mg RBV 48 weeks, 12 weeks Placebo (wk 0-12)	a) REL: 24% PR: 15% NULR: 5%
	b) 180 µg PEG-IFN α-2a, 1000-1200 mg RBV 48 weeks, 4 weeks Placebo (wk 0-4), 12 weeks 750 mg tid TLV (wk 4-16) → Lead-in cohort	b) REL: 88% PR: 54% NULR: 33%
	c) 180 µg PEG-IFN α-2a, 1000-1200 mg RBV 48 weeks, 12 weeks 750 mg tid TLV (wk 0-12), 4 weeks Placebo (wk 12-16),	c) REL: 83% PR: 59% NULR: 29%

## PEG-IFN maintenance therapy

There has been much interest concerning the use of low-dose PEG-IFN maintenance therapy in patients with a null response since data has suggested that IFN may halt progression of liver disease (Nishiguchi 1995). There are two major published trials that have analysed if maintenance treatment with IFN alters the natural course of chronic hepatitis C. In the EPIC<sup>3</sup> trial, nonresponders to IFN/RBV with compensated cirrhosis and no evidence of HCC received 0.5 µg/kg PEG-IFN α-2b or no treatment for a maximum period of 5 years or until patients developed clinical events (hepatic decompensation, HCC, death, or liver transplantation). The study revealed no significant difference in time to first clinical event among patients who received PEG-IFN compared with controls (Bruix 2011).

The HALT-C trial, a long-term maintenance study supported by the National Institutes of Health evaluated a large cohort of chronic HCV-infected patients who had failed previous IFN-based therapy and had METAVIR stage F2-F4. Patients received 90 µg PEG-IFN α-2a maintenance treatment if they did not respond during the first 20 weeks with standard therapy. Despite the fact that there were greater reductions in viremia, decreases in alanine aminotransferase, and necroinflammation in the patients who received PEG-IFN, none of the important clinical outcomes (rates of death, decompensation, hepatocellular carcinoma, and increase in fibrosis) were favourably affected by PEG-IFN therapy (Di Bisceglie 2008). In conclusion, long-term treatment with low-dose PEG-IFN cannot be recommended (Sarrazin 2010a).

## Treatment of HCV genotypes 2 and 3

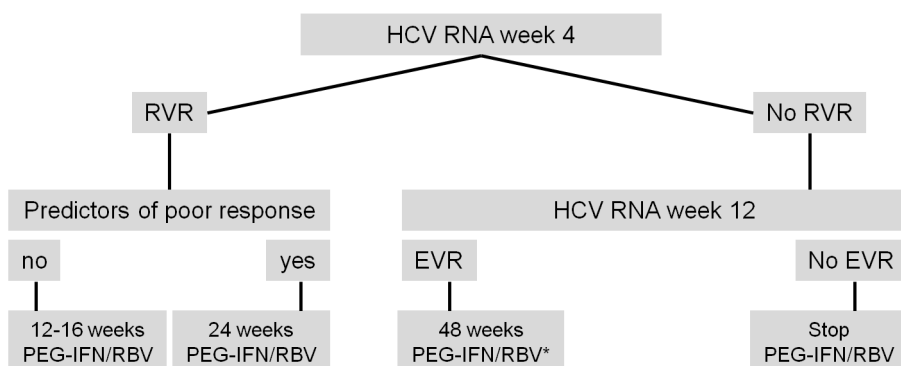
### Naïve patients

TLV shows antiviral efficacy against HCV G2 but is not effective against HCV G3 (Foster 2011). Data for BOC have only been presented in abstract form for 400 mg TID in a small number of patients (Silva 2011). Importantly, both PIs are approved only for the treatment of HCV G1. Thus, SOC for HCV G2/3 infection remains the combination of PEG-IFN/RBV. Although a fixed duration of treatment (24 weeks) has been advocated, the optimal results are likely to be achieved when the duration of therapy is adjusted based on viral kinetics. Many studies have investigated the reduction of treatment duration for HCV G2/3 to 16, 14, or even 12 weeks. Overall, reducing the treatment duration to less than 24 weeks increases the number of relapses (Andriulli 2008, Dalgard 2008, Mangia 2005, Manns 2011a, Shiffman 2007b). However, some HCV G2/3 patients may indeed be treatable for 12-16 weeks if certain prerequisites are fulfilled, especially the rapid virologic response (RVR) by week 4 of therapy (Slavenburg 2009). Only patients with RVR have high SVR rates after 16 weeks (Manns 2011a, von Wagner 2005), 14 weeks (Dalgard 2008), or even 12 weeks of therapy (Mangia 2005) (Table 7).

In addition to the RVR, the specific HCV genotype and the baseline viral load are associated with response. Patients with HCV G2 respond better to PEG-IFN/RBV therapy than those infected with HCV G3 (Zeuzem 2004b). Furthermore, the shorter treatment schedules reveal that HCV G3 patients with low baseline viremia (<400-800,000 IU/ml) had a much better chance of responding than those with high viral load (>400-800,000 IU/ml) (Shiffman 2007b, von Wagner 2005). Patients with

HCV G3 plus low viral load who achieve RVR can be treated for less than 24 weeks. However, reducing treatment duration is not recommended in patients with advanced liver fibrosis or cirrhosis, insulin resistance, diabetes mellitus, hepatic steatosis or BMI >30 kg/m<sup>2</sup> (Aghemo 2006, Sarrazin 2010a, Sarrazin 2011). Patients treated with a response-guided approach should be started on high-dose ribavirin, which appears to increase the rate of RVR in patients with HCV G2/3 undergoing short treatment (Mangia 2010b).

In contrast, HCV G2/3 patients who do not achieve RVR (especially HCV G3 and high viral load) may be treated for longer than 24 weeks (i.e., 36-48 weeks) (Figure 5). However, most data are retrospective (Willems 2007). A prospective study from Italy showed a numerically significant benefit of 36 weeks versus 24 weeks (75% vs. 62%) (Mangia 2010a). Further prospective studies investigating treatment extension to 36 or 48 weeks are ongoing. Depending on the assay used to determine RVR, around 25-30% of HCV G2/3 patients belong to this difficult-to-treat population not achieving RVR (Table 8). Tailoring treatments individually for patients with HCV G2/3 will reduce costs and side effects and further optimise the response rates.



**Figure 5. Recommendation for treatment of HCV genotypes 2 and 3.** Sensitive HCV RNA assays (limit of detection 12-15 IU/ml or 50 IU/ml) at weeks 4 and 12 may determine treatment duration. Reducing treatment duration is not recommended in patients with liver cirrhosis, insulin resistance, diabetes mellitus or hepatic steatosis.



**Table 7. Response-guided therapy for patients with HCV genotypes 2 and 3.**

Study	Treatment	Subgroups	Therapy weeks	SVR*
(von Wagner 2005) n=153	180 µg PEG-IFN α-2a 800-1200 mg ribavirin	>600 IU/ml TW4	24	36%
		<600 IU/ml TW4	24	80%, 84% if HCV RNA<800,000 IU/ml
		<600 IU/ml TW4	16	82%, 93% if HCV RNA<800,000 IU/ml
(Shiffman 2007b) n=1469	180 µg PEG-IFN α-2a 800 mg ribavirin	All patients	24	70%
		All patients	16	62%
		<50IU/ml TW4 (RVR)	24	85%
		<50IU/ml TW4 (RVR)	16	79%
		<400,000IU/ml TW0 (LVL)	24	81%
		<400,000IU/ml TW0 (LVL)	16	82%
(Mangia 2005) n=283	1.0 µg PEG-IFN α-2b 1000-1200 mg ribavirin	Standard group	24	76%
		Standard group	24	91% if TW4 HCV RNA <50 IU/ml
		>50 IU/ml TW4 (no RVR)	24	64%
		<50 IU/ml TW4 (RVR)	12	85%
(Dalgard 2008) n=428	1.5 µg PEG-IFN α-2b 800-1400 mg ribavirin	<50 IU/ml TW4 (RVR)	24	91% ITT, 93% with F24 HCV RNA test
		<50 IU/ml TW4 (RVR)	14	81% ITT, 86% with F24 HCV RNA test
		>50 IU/ml TW4 (no-RVR)	24	55% ITT, 59% with F24 HCV RNA test
(Manns 2011a) n=682	1.0 µg PEG-IFN α-2b 1.5 µg PEG-IFN α-2b 800-1400 mg ribavirin	All patients	24 (1.5)	67% ITT, 82% as treated
		All patients	24 (1.0)	64% ITT, 80% as treated
		All patients	16 (1.5)	57% ITT, 68% as treated

\* SVR, sustained viral response; RVR, rapid virologic response; LVL, low baseline viral load.

**Table 8. SVR of patients with HCV genotypes 2 or 3 not achieving RVR.**

Study	Frequency of patients without RVR	SVR without RVR (24 wks therapy)
(von Wagner 2005) 180 µg PEG-IFN α-2a 800-1200 mg ribavirin	7% (HCV RNA >600 IU/ml TW4)	36%
(Shiffman 2007b) 180 µg PEG-IFN α-2a 800 mg ribavirin	36% (HCV RNA >50 IU/ml TW4) (24 wk group)	45%
(Mangia 2005) 1.0 µg/kg PEG-IFN α-2b 1000-1200 mg ribavirin	36%-38% (HCV RNA >50 IU/ml TW4)	48%-64%
(Dalgard 2004) 1.5 µg/kg PEG-IFN α-2b 800-1400 mg ribavirin	22% (HCV RNA >50 IU/ml TW4/TW8)	56%
(Dalgard 2008) 1.5 µg/kg PEG-IFN α-2b 800-1400 mg ribavirin	29% (HCV RNA >50 IU/ml TW4)	55%

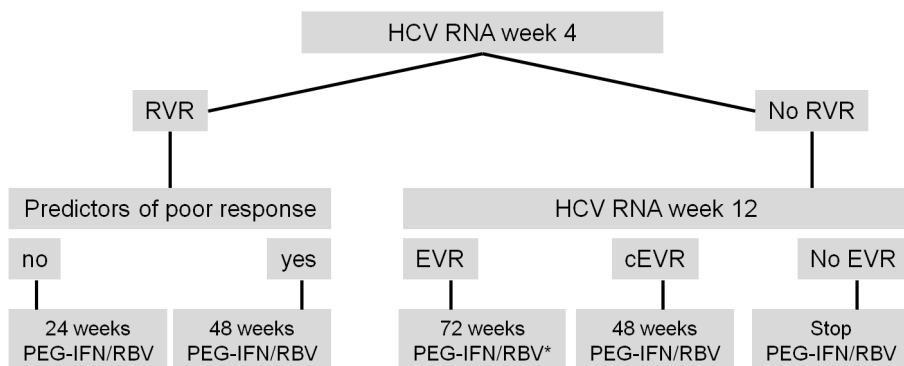
## Treatment of HCV G2/3 patients with prior antiviral treatment failure

Patients with relapse after a short course of PEG-IFN/RBV show adequate SVR after retreatment for 24 weeks (Mangia 2009). In patients with unfavourable predictors, longer treatment duration for 48 weeks is advisable (EASL 2011). Nonresponders can be retreated with an additional course of PEG-IFN/RBV. It is important to optimise dose and duration of treatment. HCV G2 nonresponders may benefit from retreatment with PEG-IFN/RBV/PI (so far only data for TLV). Triple therapy is off-label but may be considered in difficult to treat HCV G2 patients with an urgent treatment indication. Future DAAs will be pan-genotypic and therefore also effective for HCV G3 (see Chapter 14). Nonresponder patients with mild fibrosis may therefore wait for new treatment options, but it is important to understand that fibrosis progression is faster in patients with HCV G3 (Bochud 2009).

## Treatment of HCV genotypes 4, 5, and 6

BOC and TLV have hardly been tested in patients with HCV G4, 5, or 6. Neither PI is approved for the treatment of HCV G4, 5, or 6. Thus, SOC remains the combination of PEG-IFN/RBV. In general, treatment duration of 48 weeks is recommended based on the results of the large, randomized Phase III trials (Fried 2002, Hadziyannis 2004, Manns 2001). However, these trials included few patients with HCV G4, 5, and 6 and further large, prospective randomized studies with RGT are rare. Importantly, HCV G4, 5, and 6 are very common in areas where chronic hepatitis C is highly prevalent. For example, HCV G4 is most prevalent in the Middle East and Egypt where it accounts for >80% of all HCV cases (approximately 34 million patients) (Khattab 2011). HCV G5 is most prevalent in South Africa, and genotype 6 in Southeast Asia (Nguyen 2005). The available study

results, although limited, suggest that patients with HCV G4, 5 and 6 may show different clinical courses and treatment outcomes. Ethnicity-related factors (i.e., IL28B, regional aspects) may contribute to these findings. Overall, data from smaller studies suggest that HCV G4, 5 and 6 appear easier-to-treat compared to HCV G1 but the optimal treatment duration is not clear ([Antaki 2010](#), [Nguyen 2005](#)) (Table 9). Although some studies show SVR on the same order as for HCV G2/3 patients, a fixed duration of 24 weeks of treatment as for HCV G2/3 is not advisable, even for patients with HCV G6, which appears to show the best SVR ([Lam 2010](#), [Nguyen 2008](#)). RGT based on early viral kinetics should be possible. Patients who achieve RVR are candidates for a short treatment regimen of 24 weeks if they don't have predictors of poor response (see above). Based on data for HCV G1 ([Berg 2006](#), [Sanchez-Tapias 2006](#)), patients without RVR and/or partial response may be considered for 72 weeks. This has been proposed for HCV G4 by an international expert panel ([Khattab 2011](#)), but the evidence is limited. The proposed algorithm is shown in Figure 6. We suggest treating HCV G5 and 6 also according to this algorithm. Patients with treatment failure may be considered for retreatment, especially if the previous therapy was suboptimal. It is important to optimise dose and duration of treatment during retreatment.



**Figure 6. Suggestion for treatment of HCV genotypes 4, 5, and 6.** This algorithm was initially proposed for HCV G4 (adapted [Khattab 2011](#)). Sensitive HCV RNA assays (limit of detection 12-15 IU/ml or 50 IU/ml) at weeks 4 and 12 may determine treatment duration. Reducing treatment duration is not recommended in patients with predictors of poor response (liver cirrhosis, insulin resistance, diabetes mellitus or hepatic steatosis, high baseline viral load >800,000 IU/mL).

**Table 9. Efficacy of antiviral treatment with PEG-IFN plus ribavirin in patients with chronic hepatitis C infected with genotypes 4, 5, and 6. Selected trials.**

Study	Treatment	HCV genotype/Duration	SVR	
(Diago 2004) n=49	180 µg PEG-IFN $\alpha$ -2a 800/1000/1200 mg ribavirin	G4	24 weeks	0% (if low RBV)
			24 weeks	67% (if high RBV)
			48 weeks	63% (if low RBV)
			48 weeks	79% (if high RBV)
(Hasan 2004) n=66	1.5µg/kg PEG-IFN $\alpha$ -2b 1000/1200 mg ribavirin	G4	48 weeks	68%
			48 weeks	55% (if HVL)
			48 weeks	86% (if LVL)
(Kamal 2005) n=287	1.5µg/kg PEG-IFN $\alpha$ -2b 1000/1200 mg ribavirin	G4	24 weeks	29%
			36 weeks	66%
			48 weeks	69%
(Kamal 2007) n=358	1.5µg/kg PEG-IFN $\alpha$ -2b 10.6 mg/kg ribavirin RGT	G4	24 weeks RGT	86% (if RVR)
			36 weeks RGT	76% (if cEVR)
			48 weeks RGT	56% (if EVR)
			48 weeks	58%
(Ferenci 2008) n=66	180 µg PEG-IFN $\alpha$ -2a 1000/1200 mg ribavirin RGT	G4	24 weeks RGT	87% (if RVR)
(Bonny 2006) n=59	PEG-IFN $\alpha$ -2a or b 800-1200 mg ribavirin	G5	48 weeks	58%
(Lam 2010) n=60	PEG-IFN $\alpha$ -2a 800-1200 mg ribavirin	G6	24 weeks	70%
			48 weeks	79%
(Nguyen 2008) n=35	PEG-IFN $\alpha$ -2a or b 800-1200 mg ribavirin	G6	24 weeks	39%
			48 weeks	75%

RBV, ribavirin; LVL, low baseline viral load; HVL, high baseline viral load; RGT, response-guided therapy

## Optimisation of HCV treatment

### Adherence to therapy

Adherence to therapy is one of the most important factors associated with the success of antiviral treatment (McHutchison 2002). The definition of adherence used here is the “80/80 rule”, that is, patients who receive more than 80% of the medication and are treated for more than 80% of the planned duration of treatment are considered adherent. One of the first studies investigating the effect of adherence in PEG-IFN/RBV treatment demonstrated that patients who fulfilled the

80/80 rule had a 63% SVR compared to 52% of those with less than 80% adherence (McHutchison 2002). Another study showed that a cumulative ribavirin dose of more than 60% is important to achieve an SVR (Reddy 2007). For the new triple therapy, adherence to the PI becomes even more important as mentioned above. The three-times-daily regimen necessitates highly motivated and compliant patients. BOC and TLV have to be taken every 7-9 hours together with food. Reduction of the PI or irregular intake bears the risk for rapid emergence of drug resistance. Dose reduction of the PI is associated with significantly diminished SVR (Gordon 2011) and is therefore not an option to manage side effects. An optimal management of PEG-IFN/RBV side effects therefore is essential in order to optimise treatment responses. In the case of anemia, dose reduction of ribavirin is possible and not associated with impaired SVR to triple therapy (Roberts 2011). Another important and new issue is drug interactions that can diminish the effectiveness of the PI or induce toxicity of concomitant medications, which may lead to discontinuation of all drugs. Knowledge about drug interactions is therefore important for the optimal management of patients receiving PEG-IFN/RBV/PI.

## Management of side effects and complications

Severe side effects may reduce adherence to therapy and may result in dose modifications that result in a less-than-optimal response. IFN, ribavirin and the new protease inhibitors induce side effects that have to be managed with the patient (Table 10). The IFN-related side effects can be divided into IFN-induced bone marrow suppression, flu-like symptoms, neuropsychiatric disorders, and autoimmune syndromes. The main problem of ribavirin is hemolytic anemia. Boceprevir and telaprevir are associated with additional side effects such as rash or dysgeusia and additionally an increase of anemia (Table 10) (Jacobson 2011b, Manns 2011b, Vertex 2011, Zeuzem 2011). Overall, side effects result in premature withdrawals from therapy (5-17% during triple therapy depending on the duration of therapy (Jacobson 2011b)) and additional patients require dose modifications during treatment. The frequency of treatment discontinuations and dose modifications are lower in recent studies, suggesting an improved understanding and management of adverse events (Manns 2006). Similar developments are expected also for treatment with PIs. For example, the reported cases of rash decreased from 60% in Phase II (McHutchison 2009a) to 36% in the Phase III trial (Jacobson 2011b). However, the frequency of adverse events that occurred in registration trials with carefully selected patients may differ from general clinical practice, where patients with, e.g., history of psychiatric disorders or advanced liver disease are being treated. For example, factors significantly associated with developing anemia on TVR were older age and advanced fibrosis (Roberts 2011).

### IFN side effects

The effect of IFN on bone marrow results in decreased granulocytes and thrombocytes during treatment. These are usually moderate if normal counts are initially present. However, dose modifications are necessary, especially in patients with initially low counts (Manns 2006). This limits the use of IFN in patients with advanced liver cirrhosis who often have low platelets and are also more vulnerable to infections. Therapeutic concepts in order to raise platelet levels safely would have

a significant effect on the effective management of patients, especially those with advanced liver disease.

A promising novel agent is the oral thrombopoietin receptor agonist eltrombopag that has been tested in patients with chronic hepatitis C and liver cirrhosis (McHutchison 2007). Eltrombopag was able to increase platelet levels in 75-95% of patients depending on the dose, and antiviral therapy was then initiated. Twelve weeks of antiviral therapy were then taken by 36-65% of patients receiving 30-75 mg of eltrombopag vs only 6% of patients in the placebo group (McHutchison 2007). A recent Phase III study including patients with platelets  $<75$  K/ $\mu$ l has shown that eltrombopag pretreatment for 9 weeks and later combination with PEG-IFN/RBV could significantly increase SVR in comparison to eltrombopag pretreatment and later PEG-IFN/RBV/placebo (Afdhal 2011). Neutropenia is another of the most common reasons for dose modification.

Granulocyte macrophage colony stimulating factor (GM-CSF, Filgrastim) could potentially be used to stabilize neutrophil counts during IFN therapy (Shiffman 1998, Younossi 2008). While administration of GM-CSF may enable patients to remain on treatment, a systematic review documented only weak evidence that this improves the likelihood of SVR compared to dose reduction (Tandon 2011). The economic evaluation was inconclusive, therefore further cost-benefit analyses and trials are required to recommend routine use of these agents. However, IFN-induced neutropenia is generally not associated with a significant increased risk for bacterial infections (Soza 2002).

Flu-like symptoms usually occur during the first weeks of treatment and severity declines over time. These symptoms include fever, chills, headache, arthralgia, and myalgia. Antipyretic drugs such as paracetamol can help to prevent or reduce these side effects (Manns 2006).

Neuropsychiatric side effects such as irritability, severe fatigue, and apathy are frequent ( $>50\%$ ) and pose a great problem for many patients and their family members. Severe depression can occur and suicide has been reported (Janssen 1994). Psychiatric care and the use of antidepressants, especially serotonin uptake inhibitors (SSRIs) may help reduce IFN-induced depression and consequently improve adherence to hepatitis C therapy. A double-blind placebo-controlled study in 100 patients with chronic hepatitis C was terminated prematurely due to significant superiority of SSRIs over placebo in terms of decreasing scores on the Hospital Anxiety and Depression Scale (HADS). All SSRI-treated patients were able to complete IFN treatment (Kraus 2008). SSRI treatment is highly effective in HCV patients during IFN-based therapies, when starting early after the onset of clinically relevant depression. Of note, citalopram should no longer be used at doses greater than 40 mg per day because it can cause prolongation of the QT interval on the electrocardiogram. This may be of relevance during triple therapy.

IFN has immunomodulatory properties, and treatment can induce autoimmune phenomena (Wesche 2001). The most frequent problem is the development of autoimmune thyroiditis. In most cases thyroiditis starts with hyperthyroidism that later turns into hypothyroidism. Autoimmune thyroiditis has been reported in up to 20% of patients during IFN-based therapies (Costelloe 2010). However, only a few patients develop thyroid disease that requires ongoing therapy (Costelloe 2010, Tran 2011). Patients with preexisting thyroid antibodies may have a higher risk and it is

possible that hepatitis C itself may be a cause of autoimmune thyroiditis ([Ganne-Carrie 2000](#)).

Other autoimmune diseases can also be aggravated by IFN therapy (e.g., diabetes or autoimmune hepatitis). Patients with documented HCV infection may get worse during IFN treatment if an underlying autoimmune hepatitis is present. This has been observed particularly in LKM antibody-positive individuals. These patients require careful monitoring if IFN is considered as first-line treatment. However, IFN therapy seems to be safe in most HCV/anti-LKM-1-positive patients ([Dalekos 1999](#), [Todros 1995](#)).

### **Ribavirin side effects**

The main side effect of ribavirin is hemolytic anemia that frequently results in ribavirin dose reduction or even discontinuation, which may significantly affect the SVR with PEG-IFN/RBV alone ([Reddy 2007](#)). Treatment with erythropoietin (EPO) can reverse ribavirin-associated anemia and allow full adherence to ribavirin therapy ([Afdhal 2004](#)). Although the use of EPO can reduce the incidence and severity of ribavirin induced anemia, there is limited evidence that EPO has an effect on SVR. A prospective, randomized, controlled trial has evaluated the effect of EPO on SVR. Patients receiving PEG-IFN  $\alpha$ -2b plus 13.3 mg/kg/day ribavirin were compared to patients receiving PEG-IFN  $\alpha$ -2b, 13.3 mg/kg/day ribavirin and 40,000 U/week EPO. Although there were significantly fewer ribavirin dose reductions in those patients who received EPO, no improvement in SVR was shown. A third group received a higher starting dose of 15.2 mg/kg/day in combination with EPO and they did show a significantly higher SVR but there was no control group in this trial ([Shiffman 2007a](#)). A placebo-controlled trial investigated the use of 30,000 U/week EPO or placebo in addition to PEG-IFN/RBV when hemoglobin reduced to  $\leq 12$  g/dL in men and  $\leq 11$  g/dL in women. SVR was not significantly improved with EPO. Overall, EPO may improve quality of life, and in some individuals it may also improve the chance of achieving an SVR (in those requiring high doses of RBV). However, EPO use is off-label. Alternative ribavirin-like drugs with less toxicity and/or higher antiviral efficacy have failed ([Benhamou 2009](#), [Marcellin 2010](#)). Drug monitoring of ribavirin could be an option to optimise the ribavirin dose without losing efficacy ([Svensson 2000](#)). The pharmacokinetics of ribavirin suggests that not only body weight but also renal function (glomerular filtration rate) should be considered when selecting the ribavirin dose ([Bruchfeld 2002](#)). Importantly, RBV is considered as teratogenic and therefore contraindicated during and 6 months after pregnancy. Effective birth control measures are necessary ([Sarrazin 2010a](#)).

### **Protease inhibitor side effects**

Both BOC and TLV were associated with more frequent and severe anemia. Approximately 1-1.5 g/dL additional decrease of hemoglobin can be expected. The different treatment duration of both drugs results in different grades and duration of anemia. In the BOC trials, approximately 50% of patients receiving BOC experienced anemia, compared to 29% of participants who did not receive the drug ([Poordad 2011b](#)). Of note, treatment with EPO was allowed in the BOC trials. Participants in the TLV trial were not permitted to receive EPO and anemia rates were 36% and 17% for patients who did or did not receive the drug, respectively

([Jacobson 2011b](#)) (Table 10). Around 3% of participants taking TLV discontinued due to anemia, versus less than 1% of participants taking only PEG-IFN/RBV. Frequent monitoring during the first weeks of PI treatment is important. Significant anemia occurs after 4 weeks of treatment. In the case of anemia, RBV should be reduced. Importantly RBV dose reduction was not associated with diminished SVR ([Roberts 2011](#)). In the BOC trials, SVR was similar in anemic patients who were managed with RBV dose reduction versus EPO ([Sulkowski 2011](#)). A prospective trial is on going that compare EPO usage versus reduction of RBV in the management of anemia. Blood transfusion is an option to rapidly increase hemoglobin in patients with severe anemia. A total of 5% of patients in the telaprevir groups received blood transfusions compared to 2% of patients on standard therapy ([Jacobson 2011b](#)). It has to be considered that older patients with more advanced liver disease may have higher rates of anemia ([Roberts 2011](#)). The last option is to discontinue the PI. Importantly, the dose of BOC or TLV must not be reduced during therapy or restarted after discontinuation. Besides anemia, BOC and TLV may also increase neutropenia (Table 10).

Another important new side effect specific for TLV is the development of skin rash. A majority of patients receiving TLV (56%) reported the development of rash, typically pruritic and eczematous, usually involving <30% of the body surface area ([Vertex 2011](#)). Rash develops usually after 3-4 weeks but can occur at any time during TLV treatment. Rash can be mild (37%), moderate (14%) or severe (5%) ([Incivo 2011](#)). Serious, life-threatening skin reactions such as Stevens Johnson Syndrome or Drug Rash with Eosinophilia and Systemic Symptoms (DRESS) have been reported in 0.1-0.4%, respectively ([Incivo 2011](#)). Patients with developing rash must be closely monitored for progression. In the case of severe rash (generalized rash >50% of body surface area, mucous membrane ulceration, target lesions, epidermal detachment), consultation with a specialist in dermatology is recommended and treatment with TLV should be discontinued. Rash is usually reversible but it may still worsen for a few days after discontinuation of TLV and may take weeks for complete resolution. PEG-IFN/RBV may be continued if the rash improves within 7 days. Early management of rash is important to prevent progression. Topical corticosteroids and oral antihistamines (consider drug interactions) help to relieve symptoms. Systemic corticosteroids are not recommended during the early management.

Further specific adverse events concerning TLV are anal discomfort, anal pruritus and hemorrhoids, which was documented in 29% of study participants ([Vertex 2011](#)) (Table 10). In our experience, almost every patient reports symptoms if specifically asked. For most patients these symptoms were mild or moderate and do not lead to discontinuation of the drug.

A more specific adverse event for BOC is reversible dysgeusia (metallic taste), which occurred in 37% in the BOC trials (Table 10). Patients treated with TLV also experience dysgeusia, reported as a "sticky taste".

Because BOC and TLV must be used in combination with PEG-IFN/RBV, contraindications and warnings concerning PEG-IFN/RBV are also applicable to BOC and TLV. Therefore, intense care must be taken to prevent pregnancy in female patients and in female partners of male patients. Of note, oral hormonal contraception is theoretically less effective due to drug interaction with BOC or TLV. In case of patient pregnancy all drugs must be discontinued. Pregnancies



should be reported to the ribavirin pregnancy registry (<http://ribavirinpregnancyregistry.com>).

## Drug interactions

BOC and TLV undergo extensive hepatic metabolism especially by the cytochrome P450 CYP3A pathway. Thus, both PIs are target as well as perpetrator of drug interactions. As inhibitors of CYP3A, both PIs can result in increased plasma concentrations of concomitant drugs that are metabolized via the same route, leading to prolonged therapeutic effects and/or toxicity. In contrast, concomitant drugs that induce CYP3A may result in decreased plasma concentrations of BOC or TLV, which can reduce the therapeutic effect. TLV is also an inhibitor of PGP transport. Coadministration of TLV with drugs that are substrates for PGP transport may result in increased plasma concentrations of such drugs, which could increase adverse reactions. Based on *in vitro* experiments BOC also has the potential to inhibit PGP. Importantly, BOC is metabolized not only by cytochrome P450-mediated oxidation but also significantly by ketone reduction via aldo-keto reductase (AKR). Because the biotransformation and clearance of BOC involves two different enzymatic pathways, drug interactions with BOC may be less likely compared to TLV. For the optimal management of triple therapy, it is essential to specifically ask patients about concomitant medications and investigate if those drugs may interact with the PI. Even herbals and food have to be considered as St. John's Wort is a potent inducer of CYP3A and naringin, an ingredient of grapefruit, an inhibitor. A list of drug interactions is given in the prescribing information. Supportive online tools or apps for mobile devices are available. One example is the comprehensive drug interaction resource provided by the University of Liverpool (<http://www.hep-druginteractions.org>). The website provides clinically useful and evidence-based information which is updated when new drug interactions are analysed and published. Drug interactions are considered significant if the area under the plasma concentration time curve (AUC) is changed by more than 30%.

**Table 10. Common side effects (>5% of patients) recorded in the PEG-IFN/RBV/PI trials.** The incidence of side effects between different studies is difficult to compare because there were significant differences in genetic and socioeconomic backgrounds. There were methodological differences in assessing side effects as well. Patients were selected on the basis of well-defined inclusion and exclusion criteria. Important differences between PEG-IFN/RBV and PEG-IFN/RBV/PI are highlighted in bold.

Side effects	Incidence with PEG-IFN/RBV	Incidence with PEG-IFN/RBV/BOC	Incidence with PEG-IFN/RBV/TLV
Fatigue	50%†, 57%*	57%*	56%†
Insomnia	31%‡,*	32%*	32%‡
Headache	39%‡, 43%*	44%*	41%-43%‡
Pyrexia	24%‡, 31%*	31%*	26%-30%‡
Nausea	31%‡, 40%*	45%*	40-43%‡
Diarrhea	17%†, 18%*	23%*	26%†
Alopecia	25%*	26%*	n.a.
Depression	20%*	20%*	No difference‡
Anemia	17%†, 29% §,*	49%§*	36%†
Neutropenia	18%*,**	23%*	23%**
Dysgeusia	3%†, 15%*	37%*	10%†
Rash	17%*, 34%†	16%*	56%†
Pruritus	23%*, 28%†	21%*	47%†
Anorectal discomfort	1%*, 3%†	1%*	11%†
Anal pruritus	1%†	n.a.	6%†
Hemorrhoids	3%*,†	4%*	12%†

\* Manns 2011b, † Vertex 2011, ‡ Jacobson 2011b, § EPO was allowed,

\*\* Zeuzem 2011

## Treatment of hepatitis C in special populations

### Patients with acute hepatitis C

The goal of acute hepatitis C treatment is the prevention of persistent HCV infection. The natural rate of HCV evolution to a chronic state is 50-90%. As a vaccine is not yet available, early treatment of acute HCV infection with IFN is the only option to prevent persistent HCV infection; however, the diagnosis of acute primary HCV infection may be difficult and its distinction from exacerbation of an underlying unrecognized chronic HCV infection may be difficult (Sarrazin 2010a). The immediate treatment of patients with symptomatic acute hepatitis C with recombinant IFN or PEG-IFN monotherapy for 24 weeks can prevent the development of chronic hepatitis C in approximately 90% of cases (Broers 2005, Jaeckel 2001, Santantonio 2005, Vogel 1996, Wiegand 2006). However, good patient adherence to therapy is necessary to achieve these response rates (Wiegand

2006). Coadministration with ribavirin does not seem to be necessary. This may be different in patients with HIV coinfection (Grebely 2011a) (see Chapter 18). TLV and BOC have not been tested in patients with acute HCV infection. Symptomatic patients also have a good chance of clearing HCV spontaneously (Gerlach 2003, Hofer 2003), occurring usually in the first 12 weeks after the onset of symptoms.

As for patients with treatment-induced SVR, spontaneous clearance of HCV is also associated with IL28B polymorphisms and IP-10 (Beinhardt 2012, Grebely 2010, Thomas 2009, Tillmann 2010), which may be useful for decision-making. The treatment of only those patients who remain HCV RNA-positive 12 weeks after the onset of symptoms results in an overall SVR (self-limited and treatment-induced) in 91% of patients (Gerlach 2003). Asymptomatic patients, however, should probably be treated immediately since these patients have a higher risk for evolution to a chronic state. However, early treatment of acute HCV infection to prevent chronic disease does have its limitations. A main problem is that primary HCV infection is usually asymptomatic and most patients cannot be identified in this early stage of disease. Another reason is that a number of patients have medical contraindications for treatment with IFN or are not ready for therapy because they are still active intravenous drug users (IDU).

There are two concerns in treating active IDU with IFN. In case of successful therapy there is a risk of reinfection with HCV (Grebely 2011b). The second concern is the side effect profile of IFN, especially the neuropsychiatric problems that may result in a worsening of addictive behaviour (Wiegand 2006). In addition, it has been shown that the acceptance of and adherence to antiviral therapy by these patients can be low due to the side effects of IFN (Broers 2005).

There are open questions on the treatment of acute hepatitis C. For example, a study coordinated by the German Competence Network for Viral Hepatitis (Hep-Net) tested if the wait-and-see strategy for 12 weeks is as effective as immediate treatment. The first preliminary data from this trial were presented at the 2009 EASL Annual Meeting. Early treatment was superior in the intent-to-treat analysis, although this was mainly due to higher drop out rates in the delayed treatment arm. Of note, all patients who started treatment later and who completed treatment and follow-up responded to treatment. The trial also showed for the first time that early treatment is as effective in patients with asymptomatic acute hepatitis C (Deterding 2009). Thus, the decision to wait for 12 weeks after diagnosis or to treat immediately may be made individually. Importantly, the compliance of the patient should be assessed. Host genetics (IL28B), other markers (IP-10), or HCV RNA kinetics during the first weeks may help to decide when to treat. For example, asymptomatic patients with IL28B rs12979860-CT or TT may be treated immediately. In the next five to ten years we will presumably have new DAAs that will allow IFN-free therapies.

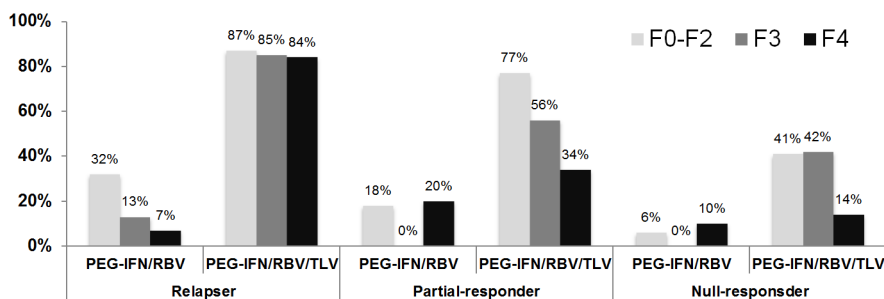
## Patients with normal aminotransferase levels

Approximately 30% of patients with chronic hepatitis C maintain persistently normal alanine aminotransferase (ALT) levels despite having detectable HCV RNA in serum. These patients have generally mild liver disease and show a slow progression to cirrhosis. However, up to one third of patients with normal ALT can present with significant liver fibrosis necessitating an effective treatment (Bacon 2002, Zeuzem 2004a). In current guidelines, ALT elevation is not a prerequisite to

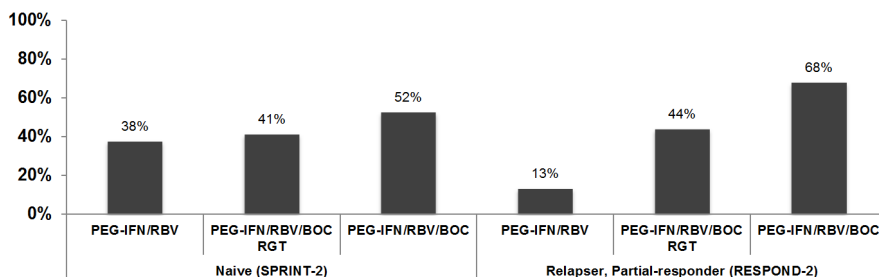
start antiviral therapy and the assessment of liver disease severity should be made regardless of ALT (EASL 2011). In general, the efficacy and safety of PEG-IFN/RBV therapy in patients with persistently normal ALT levels seems to be comparable to that seen in patients with elevated ALT levels. 48 weeks of PEG-IFN  $\alpha$ -2a plus ribavirin has been shown to lead to an SVR of 52% in patients with chronic hepatitis C and persistently normal ALT levels. Treatment-related flares in ALT activity were not observed (Zeuzem 2004a). This has been not analysed in detail for triple therapy regimes.

## Patients with compensated liver cirrhosis

Successful therapy of patients with advanced fibrosis and liver cirrhosis is associated with decreased incidence of HCC, decompensation and liver-related mortality (Morgan 2010, Veldt 2007). In addition, in patients awaiting liver transplantation, successful therapy prevents graft rejection (Everson 2005, Forns 2003). Thus, patients should be considered for therapy if no contraindications are present. However, SVR is diminished in patients with cirrhosis, for the new triple therapy as well (Pol 2011b) (Figure 7A, 7B). Patients with liver cirrhosis must be treated for a fixed duration of 48 weeks. Thus, exposure to drugs associated with side effects is still long in the new era of PIs. Treatment of patients with liver cirrhosis requires a close monitoring of patients. Hematological adverse events are more frequent than in non-cirrhotic patients (EASL 2011). Of note, patients with advanced cirrhosis (i.e., platelets  $<75\text{K}/\mu\text{l}$ ) have not been treated with BOC or TLV because they were excluded from the large Phase II and III studies. In general, treatment should be limited to patients with Child-Pugh A cirrhosis. In patients with Child-Pugh B cirrhosis, therapy may be only considered in individual cases in experienced centres. If ascites is present, antibiotic prophylaxis should be given. If patients with cirrhosis achieve SVR, it is important to perform HCC surveillance because cirrhosis remains and HCC development is reduced but not abolished (EASL 2011).



**Figure 7A. SVR of TLV-based regimens in patients with HCV genotype 1 according to fibrosis stage.** Subanalysis of the REALIZE Phase III trial (Pol 2011b).



**Figure 7B. SVR of BOC-based regimens in patients with HCV genotype 1 with advanced fibrosis and cirrhosis (F3-F4).** Subanalysis of the SPRINT-2 and RESPOND-2 trials (Bruno 2011).

## Patients after liver transplantation

HCV reinfection occurs in almost all patients after liver transplantation. While the course of hepatitis C in liver transplant recipients was believed to be rather benign in the late '80s and early '90s (Boker 1997), HCV has led to a more rapid progression post-transplant in recent years (Berenguer 2005, Neumann 2004) with cirrhosis within the first 5-10 years in 20-30% of patients. HCV definitely takes a more rapid course post-transplant than in immunocompetent individuals and treatment needs are obvious. Antiviral therapy of HCV may be started before transplant to prevent reinfection of the graft. If this approach is successful, reinfection can be prevented in two-thirds of patients (Forns 2003). However, treatment with IFN/RBV is poorly tolerated in individuals with decompensated cirrhosis with a high risk for infections and this approach is feasible in only a minority of patients (Everson 2005, Forns 2003). Preemptive treatment within the first 4-6 weeks post transplant has been disappointing with SVR between 5% and 33% for different regimens including IFN monotherapy and IFN/RBV (Terrault 2003). Studies using PEG-IFN/RBV reported an SVR of 26-48% (Carrion 2007, Dumortier 2004, Neff 2004, Roche 2008, Rodriguez-Luna 2004). Treatment duration should be at least similar to non-transplanted patients considering early viral kinetics and the HCV genotype. However, bone marrow toxicity, depression, and rejection are limiting factors that require aggressive management (e.g., growth factors) (Rodriguez-Luna 2004). The ribavirin dose may have to be adjusted since many patients have some degree of renal insufficiency. Interestingly, the risk for IFN-induced graft rejection seems to be higher if ribavirin is not used. BOC and TLV are currently being evaluated in patients after liver transplantation. Besides adverse events (anemia, neutropenia), drug interactions with immunosuppressive drugs need to be considered. For example, TLV increases levels of tacrolimus by approximately 70-fold (Garg 2011). In conclusion, patients with established graft hepatitis should be treated with PEG-IFN/RBV, but at this stage, BOC and TLV should not be used in transplant patients outside clinical trials. Whether reinfection can be prevented by currently developed DAAs will have to be addressed in future studies.

## Hemodialysis patients

Treatment needs for dialysis patients with hepatitis C are obvious especially if patients are considered for kidney transplantation. The outcome of HCV post-kidney transplantation is worse than for HCV-negative patients after renal transplantation. However, IFN-based therapies are contraindicated post-transplantation since they may induce rejection. Thus, if possible, HCV should be eliminated before transplantation. There have been several smaller reports on the treatment of HCV with IFN monotherapy in patients with end-stage renal disease (Fabrizi 2002). Surprisingly, the results for IFN monotherapy on dialysis were better than in patients not undergoing dialysis, with SVR results of 21-64%. Data on combination with ribavirin are limited since ribavirin is contraindicated in this setting. However, ribavirin can be given at lower doses in dialysis patients, usually at 200-400 mg daily (Bruchfeld 2001). It has to be considered that there may be significant differences between the two pegylated interferons in the setting of dialysis since PEG-IFN  $\alpha$ -2a is eliminated mainly by the liver while PEG-IFN  $\alpha$ -2b is cleared via the kidney (reviewed in Cornberg 2002). Thus, only PEG-IFN  $\alpha$ -2a should be used in this setting. The efficacy of BOC and TLV has not been tested in HCV patients with end stage renal disease or in patients undergoing hemodialysis. Theoretically, BOC and TLV can be administered in patients with compensated renal insufficiency and dose adjustment is not necessary because both drugs are metabolized through the liver and mainly eliminated via the feces with minimal urinary excretion (Ghany 2011).

## Drug abuse and patients on stable maintenance substitution

Treatment of patients with active drug use is an individual approach and should only be performed in an experienced multidisciplinary setting including hepatologists, psychiatrists and addictologists. Drug interactions with BOC and TLV need to be considered.

## Patients with coinfections

Due to the similar routes of transmission, patients with chronic hepatitis C are frequently coinfecting with hepatitis B virus, hepatitis D virus or human immunodeficiency virus. This important patient group is discussed in Chapters 11, 18 and 19.

## Patients with hemophilia

Due to contaminated clotting factor concentrates many patients with hemophilia are infected with HCV and/or HIV. Studies investigating PEG-IFN/RBV in hemophilia patients are limited and often include small numbers of patients. Review of available data suggest that treatment success of HCV-infected hemophiliacs is similar to that achieved in the general HCV-infected population (Franchini 2008).

## Patients with extrahepatic manifestations

More than 50% of HCV-infected patients suffer from extrahepatic manifestations ranging from fatigue to severe symptoms of mixed cryoglobulinemia (Cacoub 1999) (see Chapter 16). The primary goal of treatment is HCV eradication, which is associated with improvement of clinical symptoms, especially in patients with

mixed cryoglobulinemia (Cresta 1999, Pischke 2008, Zignego 2007). Insulin resistance can be improved in HCV G1 patients with SVR (Thompson 2012). In patients with severe symptoms of mixed cryoglobulinemia, treatment with rituximab may be considered (Cacoub 2008). Recent studies have also tested the combination of PEG-IFN/RBV and rituximab. The clinical response may be achieved faster and SVR is not diminished in patients who receive rituximab (Dammacco 2010, Saadoun 2010). Exacerbation of certain extrahepatic manifestations may occur with IFN-based therapy or IFN may be contraindicated (Zignego 2007). BOC and TLV have not been investigated in patients with extrahepatic manifestations.

## References

- Afdhal N, Dusheiko G, Giannini EG, et al. Final results of enable 1, a phase 3, multicenter study of eltrombopag as an adjunct for antiviral treatment of hepatitis c virus-related chronic liver disease associated with thrombocytopenia. *Hepatology* 2011;54:1427A-28A.
- Afdhal NH, Dieterich DT, Pockros PJ, et al. Epoetin alfa maintains ribavirin dose in HCV-infected patients: a prospective, double-blind, randomized controlled study. *Gastroenterology* 2004;126:1302-11. (Abstract)
- Aghemo A, Rumi MG, Soffredini R, et al. Impaired response to interferon-alpha2b plus ribavirin in cirrhotic patients with genotype 3a hepatitis C virus infection. *Antivir Ther* 2006;11:797-802. (Abstract)
- Andriulli A, Mangia A, Iacobellis A, Ippolito A, Leandro G, Zeuzem S. Meta-analysis: the outcome of anti-viral therapy in HCV genotype 2 and genotype 3 infected patients with chronic hepatitis. *Aliment Pharmacol Ther* 2008;28:397-404. (Abstract)
- Antaki N, Craxi A, Kamal S et al. The neglected hepatitis C virus genotypes 4, 5 and 6: an international consensus report. *Liver Int* 2010;30:342-55. (Abstract)
- Ascione A, De Luca M, Tartaglione MT et al. Peginterferon alfa-2a plus ribavirin is more effective than peginterferon alfa-2b plus ribavirin for treating chronic hepatitis C virus infection. *Gastroenterology* 2010;138:116-22. (Abstract)
- Backus LI, Boothroyd DB, Phillips BR, Belperio P, Halloran J, Mole LA. A sustained virologic response reduces risk of all-cause mortality in patients with hepatitis C. *Clin Gastroenterol Hepatol* 2011;9:509-516.e1. (Abstract)
- Bacon BR. Treatment of patients with hepatitis C and normal serum aminotransferase levels. *Hepatology* 2002;36:S179-84. (Abstract)
- Bacon BR, Gordon SC, Lawitz E et al. Boceprevir for previously treated chronic HCV genotype 1 infection. *N Engl J Med* 2011;364:1207-17. (Abstract)
- Beinhardt S, Aberle JH, Strasser M et al. Serum Level of IP-10 Increases Predictive Value of IL28B Polymorphisms for Spontaneous Clearance of Acute HCV Infection. *Gastroenterology* 2012;142:78-85.e2. (Abstract)
- Benhamou Y, Afdhal NH, Nelson DR, et al. A phase III study of the safety and efficacy of virmidine versus ribavirin in treatment-naive patients with chronic hepatitis C: viser1 results. *Hepatology* 2009;50:717-26. (Abstract)
- Berenguer M. What determines the natural history of recurrent hepatitis C after liver transplantation? *J Hepatol* 2005;42:448-56. (Abstract)
- Berg T, Andreone P, Pol S, et al. Predictors of virologic response with telaprevir-based combination treatment in HCV genotype 1-infected patients with prior peginterferon/ribavirin treatment failure: post-hoc analysis of the phase III realize study. *Hepatology* 2011;54:375A-376A.
- Berg T, von Wagner M, Nasser S, et al. Extended treatment duration for hepatitis C virus type 1: comparing 48 versus 72 weeks of peginterferon-alfa-2a plus ribavirin. *Gastroenterology* 2006;130:1086-97. (Abstract)
- Berg T, Weich V, Teuber G, et al. Individualized treatment strategy according to early viral kinetics in hepatitis C virus type 1-infected patients. *Hepatology* 2009;50:369-77. (Abstract)
- Bochud PY, Cai T, Overbeck K, et al. Genotype 3 is associated with accelerated fibrosis progression in chronic hepatitis C. *J Hepatol* 2009;51:655-66. (Abstract)

- Boker KH, Dalley G, Bahr MJ, et al. Long-term outcome of hepatitis C virus infection after liver transplantation. *Hepatology* 1997;25:203-10. ([Abstract](#))
- Bonny C, Fontaine H, Poynard T, et al. Effectiveness of interferon plus ribavirin combination in the treatment of naive patients with hepatitis C virus type 5. A French multicentre retrospective study. *Aliment Pharmacol Ther* 2006;24:593-600. ([Abstract](#))
- Broers B, Helbling B, Francois A, et al. Barriers to interferon-alpha therapy are higher in intravenous drug users than in other patients with acute hepatitis C. *J Hepatol* 2005;42:323-28. ([Abstract](#))
- Bruchfeld A, Lindahl K, Schvarcz R, Stahle L. Dosage of ribavirin in patients with hepatitis C should be based on renal function: a population pharmacokinetic analysis. *Ther Drug Monit* 2002;24:701-8. ([Abstract](#))
- Bruchfeld A, Stahle L, Andersson J, Schvarcz R. Ribavirin treatment in dialysis patients with chronic hepatitis C virus infection--a pilot study. *J Viral Hepat* 2001;8:287-92. ([Abstract](#))
- Bruix J, Poynard T, Colombo M, et al. Maintenance therapy with peginterferon alfa-2b does not prevent hepatocellular carcinoma in cirrhotic patients with chronic hepatitis C. *Gastroenterology* 2011;140:1990-9. ([Abstract](#))
- Bruno S, Vierling JM, Esteban R, et al. Boceprevir in addition to standard of care enhanced svr in hepatitis C virus (HCV) genotype-1 with advanced fibrosis/cirrhosis: subgroup analysis of sprint-2 and respond-2 studies. *J Hepatol* 2011;54:S4-S4.
- Cacoub P, Delluc A, Saadoun D, Landau DA, Sene D. Anti-CD20 monoclonal antibody (rituximab) treatment for cryoglobulinemic vasculitis: where do we stand? *Ann Rheum Dis* 2008;67:283-87. ([Abstract](#))
- Cacoub P, Poynard T, Ghillani P, et al. Extrahepatic manifestations of chronic hepatitis C. MULTIVIRC Group. Multidepartment Virus C. *Arthritis Rheum* 1999;42:2204-12. ([Abstract](#))
- Carrion JA, Navasa M, Garcia-Retortillo M, et al. Efficacy of antiviral therapy on hepatitis C recurrence after liver transplantation: a randomized controlled study. *Gastroenterology* 2007;132:1746-56. ([Abstract](#))
- Choo QL, Kuo G, Weiner AJ, Overby LR, Bradley DW, Houghton M. Isolation of a cDNA clone derived from a blood-borne non-A, non-B viral hepatitis genome. *Science* 1989;244:359-62. ([Abstract](#))
- Cornberg M, Razavi HA, Alberti A, et al. A systematic review of hepatitis C virus epidemiology in Europe, Canada and Israel. *Liver Int* 2011;31 Suppl 2:30-60. ([Abstract](#))
- Cornberg M, Wedemeyer H, Manns MP. Treatment of chronic hepatitis C with pegylated interferon and ribavirin. *Curr Gastroenterol Rep* 2002;4:23-30. ([Abstract](#))
- Costelloe SJ, Wassef N, Schulz J, et al. Thyroid dysfunction in a UK hepatitis C population treated with interferon-alpha and ribavirin combination therapy. *Clin Endocrinol (Oxf)* 2010;73:249-56. ([Abstract](#))
- Cresta P, Musset L, Cacoub P, et al. Response to interferon alpha treatment and disappearance of cryoglobulinaemia in patients infected by hepatitis C virus. *Gut* 1999;45:122-28. ([Abstract](#))
- Dalekos GN, Wedemeyer H, Obermayer-Straub P, et al. Epitope mapping of cytochrome P450D6 autoantigen in patients with chronic hepatitis C during alpha-interferon treatment. *J Hepatol* 1999;30:366-75. ([Abstract](#))
- Dalgard O, Bjoro K, Hellum KB, et al. Treatment with pegylated interferon and ribavirin in HCV infection with genotype 2 or 3 for 14 weeks: a pilot study. *Hepatology* 2004;40:1260-65. ([Abstract](#))
- Dalgard O, Bjoro K, Ring-Larsen H, et al. Pegylated interferon alfa and ribavirin for 14 versus 24 weeks in patients with hepatitis C virus genotype 2 or 3 and rapid virological response. *Hepatology* 2008;47:35-42. ([Abstract](#))
- Dammacco F, Tucci FA, Lauletta G, et al. Pegylated interferon-alpha, ribavirin, and rituximab combined therapy of hepatitis C virus-related mixed cryoglobulinemia: a long-term study. *Blood* 2010;116:343-53. ([Abstract](#))
- Darling JM, Aerssens J, Fanning G, et al. Quantitation of pretreatment serum interferon-gamma-inducible protein-10 improves the predictive value of an IL28B gene polymorphism for hepatitis C treatment response. *Hepatology* 2011;53:14-22. ([Abstract](#))
- Davis GL, Alter MJ, El-Serag H, Poynard T, Jennings LW. Aging of hepatitis C virus (HCV)-infected persons in the United States: a multiple cohort model of HCV prevalence and disease progression. *Gastroenterology* 2010;138:513-21, 521.e1-6. ([Abstract](#))



- Deterding K, Gruener N, Wiegand J, et al. Early versus delayed treatment of acute hepatitis C: the German hep-net acute HCV-iii study - a randomized controlled trial. *J Hepatol* 2009;50:S380-S380.
- Di Bisceglie AM, Shiffman ML, Everson GT, et al. Prolonged therapy of advanced chronic hepatitis C with low-dose peginterferon. *N Engl J Med* 2008;359:2429-41. ([Abstract](#))
- Diago M, Hassanein T, Rodes J, Ackrill AM, Sedarati F. Optimized virologic response in hepatitis C virus genotype 4 with peginterferon-alpha2a and ribavirin. *Ann Intern Med* 2004;140:72-3. ([Abstract](#))
- Dumortier J, Scoazec JY, Chevallier P, Boillot O. Treatment of recurrent hepatitis C after liver transplantation: a pilot study of peginterferon alfa-2b and ribavirin combination. *J Hepatol* 2004;40:669-74. ([Abstract](#))
- EASL Clinical Practice Guidelines: management of hepatitis C virus infection. *J Hepatol* 2011;55:245-64. ([PDF](#))
- Everson GT, Trotter J, Forman L, et al. Treatment of advanced hepatitis C with a low accelerating dosage regimen of antiviral therapy. *Hepatology* 2005;42:255-62. ([Abstract](#))
- Fabrizi F, Poordad FF, Martin P. Hepatitis C infection and the patient with end-stage renal disease. *Hepatology* 2002;36:3-10. ([Abstract](#))
- Fattovich G, Covolo L, Bibert S, et al. IL28B polymorphisms, IP-10 and viral load predict virological response to therapy in chronic hepatitis C. *Aliment Pharmacol Ther* 2011;33:1162-72. ([Abstract](#))
- Ferenci P, Laferl H, Scherzer TM, et al. Peginterferon alfa-2a and ribavirin for 24 weeks in hepatitis C type 1 and 4 patients with rapid virological response. *Gastroenterology* 2008;135:451-58. ([Abstract](#))
- Flamm S, Lawitz E, Jacobson I, et al. High sustained virologic response (SVR) among genotype 1 previous non-responders and relapsers to peginterferon/ribavirin when re-treated with boceprevir (BOC) plus peginterferon alfa-2a/ribavirin. *J Hepatol* 2011;54:S541-S542.
- Forns X, Garcia-Retortillo M, Serrano T, et al. Antiviral therapy of patients with decompensated cirrhosis to prevent recurrence of hepatitis C after liver transplantation. *J Hepatol* 2003;39:389-96. ([Abstract](#))
- Foster GR, Hezode C, Bronowicki JP, et al. Telaprevir alone or with peginterferon and ribavirin reduces HCV RNA in patients with chronic genotype 2 but not genotype 3 infections. *Gastroenterology* 2011;141:881-9.e1. ([Abstract](#))
- Franchini M, Mengoli C, Veneri D, Mazzi R, Lippi G, Cruciani M. Treatment of chronic hepatitis C in haemophilic patients with interferon and ribavirin: a meta-analysis. *J Antimicrob Chemother* 2008;61:1191-1200. ([Abstract](#))
- Fried MW, Shiffman ML, Reddy KR, et al. Peginterferon alfa-2a plus ribavirin for chronic hepatitis C virus infection. *N Engl J Med* 2002;347:975-82. ([Abstract](#))
- Ganne-Carrie N, Medini A, Coderc E, et al. Latent autoimmune thyroiditis in untreated patients with HCV chronic hepatitis: a case-control study. *J Autoimmun* 2000;14:189-93. ([Abstract](#))
- Garg V, van Heeswijk R, Lee JE, Alves K, Nadkarni P, Luo X. Effect of telaprevir on the pharmacokinetics of cyclosporine and tacrolimus. *Hepatology* 2011;54:20-7. ([Abstract](#))
- Ge D, Fellay J, Thompson AJ, et al. Genetic variation in IL28B predicts hepatitis C treatment-induced viral clearance. *Nature* 2009;461:399-401. ([Abstract](#))
- Gerlach JT, Diepolder HM, Zachoval R, et al. Acute hepatitis C: high rate of both spontaneous and treatment-induced viral clearance. *Gastroenterology* 2003;125:80-8. ([Abstract](#))
- Ghany MG, Nelson DR, Strader DB, Thomas DL, Seeff LB. An update on treatment of genotype 1 chronic hepatitis C virus infection: 2011 practice guideline by the American Association for the Study of Liver Diseases. *Hepatology* 2011;54:1433-44. ([Free full-text](#))
- Gordon SC, Lawitz EJ, Bacon BR, et al. Adherence to assigned dosing regimen and sustained virologic response among hepatitis c genotype 1 treatment-naive and peg/ribavirin treatment-failures treated with boceprevir plus peginterferon alfa-2b/ribavirin. *J Hepatol* 2011;54:S173-S174.
- Grebely J, Matthews GV, Dore GJ. Treatment of acute HCV infection. *Nat Rev Gastroenterol Hepatol* 2011a;8:265-74. ([Abstract](#))

- Grebely J, Petoumenos K, Hellard M, et al. Potential role for interleukin-28B genotype in treatment decision-making in recent hepatitis C virus infection. *Hepatology* 2010;52:1216-24. ([Abstract](#))
- Grebely J, Pham ST, Matthews GV, et al. Hepatitis C virus reinfection and superinfection among treated and untreated participants with recent infection. *Hepatology* 2011b. [Epub ahead of print] ([Abstract](#))
- Hadziyannis SJ, Sette HJ, Morgan TR, et al. Peginterferon-alpha2a and ribavirin combination therapy in chronic hepatitis C: a randomized study of treatment duration and ribavirin dose. *Ann Intern Med* 2004;140:346-55. ([Abstract](#))
- Harrington PR, Zeng W, Naeger LK. Clinical relevance of detectable but not quantifiable hepatitis C virus RNA during boceprevir or telaprevir treatment. *Hepatology* 2011. [Epub ahead of print] ([Abstract](#))
- Hasan F, Asker H, Al-Khaldi J, et al. Peginterferon alfa-2b plus ribavirin for the treatment of chronic hepatitis C genotype 4. *Am J Gastroenterol* 2004;99:1733-7. ([Abstract](#))
- Hofer H, Watkins-Riedel T, Janata O, et al. Spontaneous viral clearance in patients with acute hepatitis C can be predicted by repeated measurements of serum viral load. *Hepatology* 2003;37:60-4. ([Abstract](#))
- Hoofnagle JH, Mullen KD, Jones DB, et al. Treatment of chronic non-A,non-B hepatitis with recombinant human alpha interferon. A preliminary report. *N Engl J Med* 1986;315:1575-8. ([Abstract](#))
- INCIVO (telaprevir) EU SmPC 2011. [PDF](#), 147 pages. Accessed on February 25, 2012.
- Jacobson IM, Brown RSJ, Freilich B, et al. Peginterferon alfa-2b and weight-based or flat-dose ribavirin in chronic hepatitis C patients: a randomized trial. *Hepatology* 2007;46:971-81. ([Abstract](#))
- Jacobson IM, Catlett I, Marcellin P, et al. Telaprevir substantially improved SVR rates across all IL28B genotypes in the ADVANCE trial. *J Hepatol* 2011a;54:S542-S543.
- Jacobson IM, mchutchison JG, Dusheiko G, et al. Telaprevir for previously untreated chronic hepatitis C virus infection. *N Engl J Med* 2011b;364:2405-16. ([Abstract](#))
- Jaeckel E, Cornberg M, Wedemeyer H, et al. Treatment of acute hepatitis C with interferon alfa-2b. *N Engl J Med* 2001;345:1452-57. ([Abstract](#))
- Janssen HL, Brouwer JT, van der Mast RC, Schalm SW. Suicide associated with alfa-interferon therapy for chronic viral hepatitis. *J Hepatol* 1994;21:241-3. ([Abstract](#))
- Jensen DM, Marcellin P, Freilich B, et al. Re-treatment of patients with chronic hepatitis C who do not respond to peginterferon-alpha2b: a randomized trial. *Ann Intern Med* 2009;150:528-540. ([Abstract](#))
- Jensen DM, Morgan TR, Marcellin P, et al. Early identification of HCV genotype 1 patients responding to 24 weeks peginterferon alpha-2a (40 kd)/ribavirin therapy. *Hepatology* 2006;43:954-60. ([Abstract](#))
- Kamal SM, El Kamary SS, Shardell MD, et al. Pegylated interferon alpha-2b plus ribavirin in patients with genotype 4 chronic hepatitis C: The role of rapid and early virologic response. *Hepatology* 2007;46:1732-40. ([Abstract](#))
- Kamal SM, El Tawil AA, Nakano T, et al. Peginterferon {alpha}-2b and ribavirin therapy in chronic hepatitis C genotype 4: impact of treatment duration and viral kinetics on sustained virologic response. *Gut* 2005;54:858-66. ([Abstract](#))
- Khattab MA, Ferenci P, Hadziyannis SJ, et al. Management of hepatitis C virus genotype 4: recommendations of an international expert panel. *J Hepatol* 2011;54:1250-62. ([Abstract](#))
- Kieffer TL, Sarrazin C, Miller JS, et al. Telaprevir and pegylated interferon-alpha-2a inhibit wild-type and resistant genotype 1 hepatitis C virus replication in patients. *Hepatology* 2007;46:631-9. ([Abstract](#))
- Kraus MR, Schafer A, Schottker K, et al. Therapy of interferon-induced depression in chronic hepatitis C with citalopram: a randomised, double-blind, placebo-controlled study. *Gut* 2008;57:531-6. ([Abstract](#))
- Kuntzen T, Timm J, Berical A, et al. Naturally occurring dominant resistance mutations to hepatitis C virus protease and polymerase inhibitors in treatment-naive patients. *Hepatology* 2008;48:1769-78. ([Abstract](#))
- Kwo PY, Lawitz EJ, McCone J, et al. Efficacy of boceprevir, an NS3 protease inhibitor, in combination with peginterferon alfa-2b and ribavirin in treatment-naive patients with genotype 1 hepatitis C infection (SPRINT-1): an open-label, randomised, multicentre phase 2 trial. *Lancet* 2010;376:705-16. ([Abstract](#))

- Lam KD, Trinh HN, Do ST, et al. Randomized controlled trial of pegylated interferon-alfa 2a and ribavirin in treatment-naive chronic hepatitis C genotype 6. *Hepatology* 2010;52:1573-80. (Abstract)
- Mangia A, Bandiera F, Montalto G, et al. Individualized treatment with combination of Peg-interferon alpha 2b and ribavirin in patients infected with HCV genotype 3. *J Hepatol* 2010a;53:1000-5. (Abstract)
- Mangia A, Dalgard O, Minerva N, et al. Ribavirin dosage in patients with HCV genotypes 2 and 3 who completed short therapy with peg-interferon alpha-2b and ribavirin. *Aliment Pharmacol Ther* 2010b;31:1346-53. (Abstract)
- Mangia A, Minerva N, Bacca D, et al. Determinants of relapse after a short (12 weeks) course of antiviral therapy and re-treatment efficacy of a prolonged course in patients with chronic hepatitis C virus genotype 2 or 3 infection. *Hepatology* 2009;49:358-63. (Abstract)
- Mangia A, Santoro R, Minerva N, et al. Peginterferon alfa-2b and ribavirin for 12 vs. 24 weeks in HCV genotype 2 or 3. *N Engl J Med* 2005;352:2609-17. (Abstract)
- Mangia A, Thompson AJ, Santoro R, et al. An IL28B polymorphism determines treatment response of hepatitis C virus genotype 2 or 3 patients who do not achieve a rapid virologic response. *Gastroenterology* 2010c;139:821-7, 827.e1.
- Manns M, Lindsay KL, Gordon SC, et al. Sustained virologic response after peginterferon alfa-2b and ribavirin treatment predicts long-term clearance of HCV at 5-year follow-up. *J Hepatol* 2008;48:S300-S300.
- Manns M, Zeuzem S, Sood A, et al. Reduced Dose and Duration of Peginterferon alfa-2b and Weight-Based Ribavirin in Patients With Genotype 2 and 3 Chronic Hepatitis C. *J Hepatol* 2011a;55:554-63. (Abstract)
- Manns MP, Felizarta F, Schiff E, et al. Overall safety profile of boceprevir plus peginterferon alfa-2b/ribavirin. *J Hepatol* 2011b;54:S183-S183.
- Manns MP, mchutchison JG, Gordon SC, et al. Peginterferon alfa-2b plus ribavirin compared with interferon alfa-2b plus ribavirin for initial treatment of chronic hepatitis C: a randomised trial. *Lancet* 2001;358:958-65. (Abstract)
- Manns MP, Wedemeyer H, Cornberg M. Treating viral hepatitis C: efficacy, side effects, and complications. *Gut* 2006;55, 1350-9. (Abstract)
- Marcellin P, Gish RG, Gitlin N, et al. Safety and efficacy of viremagine versus ribavirin in vizer2: randomized, double-blind study in therapy-naive hepatitis C patients. *J Hepatol* 2010;52:32-8. (Abstract)
- McHutchison JG, Dusheiko G, Shiffman ML, et al. Eltrombopag for thrombocytopenia in patients with cirrhosis associated with hepatitis C. *N Engl J Med* 2007;357:2227-36. (Abstract)
- McHutchison JG, Everson GT, Gordon SC, et al. Telaprevir with peginterferon and ribavirin for chronic HCV genotype 1 infection. *N Engl J Med* 2009a;360:1827-38. (Abstract)
- McHutchison JG, Gordon SC, Schiff ER, et al. Interferon alfa-2b alone or in combination with ribavirin as initial treatment for chronic hepatitis C. *Hepatitis Interventional Therapy Group*. *N Engl J Med* 1998;339:1485-92. (Abstract)
- McHutchison JG, Lawitz EJ, Shiffman ML, et al. Peginterferon alfa-2b or alfa-2a with ribavirin for treatment of hepatitis C infection. *N Engl J Med* 2009b;361:580-93. (Abstract)
- McHutchison JG, Manns M, Patel K, et al. Adherence to combination therapy enhances sustained response in genotype-1-infected patients with chronic hepatitis C. *Gastroenterology* 2002;123:1061-9. (Abstract)
- McHutchison JG, Manns MP, Muir AJ, et al. Telaprevir for previously treated chronic HCV infection. *N Engl J Med* 2010;362:1292-1303. (Abstract)
- Mederacke I, Wedemeyer H, Manns MP. Boceprevir, an NS3 serine protease inhibitor of hepatitis C virus, for the treatment of HCV infection. *Curr Opin Investig Drugs* 2009;10:181-9. (Abstract)
- Morgan TR, Ghany MG, Kim HY, et al. Outcome of sustained virological responders with histologically advanced chronic hepatitis C. *Hepatology* 2010;52:833-44. (Abstract)
- Muir AJ, Poordad FF, McHutchison JG, et al. Retreatment with telaprevir combination therapy in hepatitis C patients with well-characterized prior treatment response. *Hepatology* 2011;54:1538-46. (Abstract)
- Neff GW, O'Brien CB, Cirocco R, et al. Prediction of sustained virological response in liver transplant recipients with recurrent hepatitis C virus following combination pegylated interferon alfa-2b and ribavirin therapy using tissue hepatitis C virus reverse

- transcriptase polymerase chain reaction testing. *Liver Transpl* 2004;10:595-8. (Abstract)
- Neumann UP, Berg T, Bahra M, et al. Long-term outcome of liver transplants for chronic hepatitis C: a 10-year follow-up. *Transplantation* 2004;77:226-31. (Abstract)
- Nguyen MH, Keeffe EB. Prevalence and treatment of hepatitis C virus genotypes 4, 5, and 6. *Clin Gastroenterol Hepatol* 2005;3:S97-S101. (Abstract)
- Nguyen MH, Trinh HN, Garcia R, Nguyen G, Lam KD, Keeffe EB. Higher rate of sustained virologic response in chronic hepatitis C genotype 6 treated with 48 weeks versus 24 weeks of peginterferon plus ribavirin. *Am J Gastroenterol* 2008;103:1131-5. (Abstract)
- Nishiguchi S, Kuroki T, Nakatani S, et al. Randomised trial of effects of interferon-alpha on incidence of hepatocellular carcinoma in chronic active hepatitis C with cirrhosis. *Lancet* 1995;346:1051-5. (Abstract)
- Pischke S, Cornberg M, Manns MP. [Hepatitis associated cryoglobulinemia]. *Internist (Berl)* 2008;49:297-304. (Abstract)
- Pol S, Aerssens J, Zeuzem S, et al. Similar SVR rates in IL28b cc, ct or tt prior relapser, partial- or null-responder patients treated with telaprevir/peginterferon/ribavirin: retrospective analysis of the realize study. *J Hepatol* 2011a;54:S6-S7.
- Pol S, Roberts SK, Andreone P, et al. Efficacy and safety of telaprevir-based regimens in cirrhotic patients with hcv genotype 1 and prior peginterferon/ribavirin treatment failure: subanalysis of the realize phase III study. *Hepatology* 2011b;54:374A-375A.
- Poordad F, Bronowicki JP, Gordon SC, et al. IL28b polymorphism predicts virologic response in patients with hepatitis c genotype 1 treated with boceprevir (boc) combination therapy. *J Hepatol* 2011;54:S6-S6.
- Poordad F, mccone JJ, Bacon BR, et al. Boceprevir for untreated chronic HCV genotype 1 infection. *N Engl J Med* 2011;364:1195-206. (Abstract)
- Poynard T, Colombo M, Bruix J, et al. Peginterferon alpha-2b and ribavirin: effective in patients with hepatitis C who failed interferon alpha/ribavirin therapy. *Gastroenterology* 2009;136:1618-28.e2. (Abstract)
- Poynard T, Marcellin P, Lee SS, et al. Randomised trial of interferon alpha2b plus ribavirin for 48 weeks or for 24 weeks versus interferon alpha2b plus placebo for 48 weeks for treatment of chronic infection with hepatitis C virus. International Hepatitis Interventional Therapy Group (IHIT). *Lancet* 1998;352:1426-32. (Abstract)
- Rauch A, Kutalik Z, Descombes P, et al. Genetic variation in IL28B is associated with chronic hepatitis C and treatment failure: a genome-wide association study. *Gastroenterology* 2010;138:1338-45. (Abstract)
- Reddy KR, Shiffman ML, Morgan TR, et al. Impact of ribavirin dose reductions in hepatitis C virus genotype 1 patients completing peginterferon alpha-2a/ribavirin treatment. *Clin Gastroenterol Hepatol* 2007;5:124-29. (Abstract)
- Roberts SK, Andreone P, Pol S, et al. Impact of anemia and ribavirin dose reduction on svr to a telaprevir-based regimen in patients with hcv genotype 1 and prior peginterferon/ribavirin treatment failure in the phase III realize study. *Hepatology* 2011;54:1007A-1008A.
- Roche B, Sebagh M, Canfora ML, et al. Hepatitis C virus therapy in liver transplant recipients: response predictors, effect on fibrosis progression, and importance of the initial stage of fibrosis. *Liver Transpl* 2008;14:1766-77. (Abstract)
- Rodriguez-Luna H, Khatib A, Sharma P, et al. Treatment of recurrent hepatitis C infection after liver transplantation with combination of pegylated interferon alpha2b and ribavirin: an open-label series. *Transplantation* 2004;77:190-4. (Abstract)
- Rumi MG, Aghemo A, Prati GM, et al. Randomized study of peginterferon-alpha2a plus ribavirin vs peginterferon-alpha2b plus ribavirin in chronic hepatitis C. *Gastroenterology* 2010;138:108-15. (Abstract)
- Saadoun D, Resche Rigon M, Sene D, et al. Rituximab plus Peg-interferon-alpha/ribavirin compared with Peg-interferon-alpha/ribavirin in hepatitis C-related mixed cryoglobulinemia. *Blood* 2010;116:326-34. (Abstract)
- Sanchez-Tapias JM, Diago M, Escartin P, et al. Peginterferon-alpha2a plus ribavirin for 48 versus 72 weeks in patients with detectable hepatitis C virus RNA at week 4 of treatment. *Gastroenterology* 2006;131:451-60. (Abstract)
- Santantonio T, Fasano M, Sinisi E, et al. Efficacy of a 24-week course of PEG-interferon alpha-2b monotherapy in patients with acute hepatitis C after failure of spontaneous clearance. *J Hepatol* 2005;42:329-33. (Abstract)

- Sarrazin C, Berg T, Ross RS, et al. [Prophylaxis, diagnosis and therapy of hepatitis C virus (HCV) infection: the German guidelines on the management of HCV infection]. *Z Gastroenterol* 2010a;48:289-351. ([Abstract](#))
- Sarrazin C, T B, Cornberg M, et al. Expertenempfehlungen zur Triple-Therapie der HCV Infektion mit Boceprevir und Telaprevir. *Z Gastroenterol* 2012; in press. ([Abstract](#))
- Sarrazin C, Kieffer TL, Bartels D, et al. Dynamic hepatitis C virus genotypic and phenotypic changes in patients treated with the protease inhibitor telaprevir. *Gastroenterology* 2007;132:1767-77. ([Abstract](#))
- Sarrazin C, Schwendy S, Moller B, et al. Improved responses to pegylated interferon alfa-2b and ribavirin by individualizing treatment for 24-72 weeks. *Gastroenterology* 2011a;141:1656-64. ([Abstract](#))
- Sarrazin C, Susser S, Doehring A, et al. Importance of IL28B gene polymorphisms in hepatitis C virus genotype 2 and 3 infected patients. *J Hepatol* 2011b;54:415-21. ([Abstract](#))
- Sarrazin C, Zeuzem S. Resistance to direct antiviral agents in patients with hepatitis C virus infection. *Gastroenterology* 2010b;138:447-62. ([Abstract](#))
- Serfaty L, Forns X, Gooser T, et al. No impact of insulin resistance on antiviral efficacy of telaprevir-based regimen in hcv genotype 1 treatment-naive patients: sub-analysis of c208 study. *Hepatology* 2010;52:705A-705A.
- Shepard CW, Finelli L, Alter MJ. Global epidemiology of hepatitis C virus infection. *Lancet Infect Dis* 2005;5:558-67. ([Abstract](#))
- Sherman KE, Flamm SL, Afdhal NH, et al. Response-guided telaprevir combination treatment for hepatitis C virus infection. *N Engl J Med* 2011;365:1014-24. ([Abstract](#))
- Sherman KE, Sulkowski MS, Zoulim F, et al. Follow-up of svr durability and viral resistance in patients with chronic hepatitis c treated with telaprevir-based regimens: interim analysis of the extend study. *Hepatology* 2011;54:485A-486A.
- Shiffman ML, Hofmann CM, Luketic VA, Sanyal AJ. Use of granulocyte macrophage colony stimulating factor alone or in combination with interferon-alpha-2b for treatment of chronic hepatitis C. *J Hepatol* 1998;28:382-9. ([Abstract](#))
- Shiffman ML, Salvatore J, Hubbard S, et al. Treatment of chronic hepatitis C virus genotype 1 with peginterferon, ribavirin, and epoetin alpha. *Hepatology* 2007a;46:371-9. ([Abstract](#))
- Shiffman ML, Suter F, Bacon BR, et al. Peginterferon alfa-2a and ribavirin for 16 or 24 weeks in HCV genotype 2 or 3. *N Engl J Med* 2007b;357:124-34. ([Abstract](#))
- Silva M, Kasserra C, Gupta S, Treitel MA, Hughes E, O'Mara E. Antiviral Activity of Boceprevir Monotherapy in Treatment-Naive Subjects With Chronic Hepatitis C Genotype 2/3. *APASL* 2011.
- Slavenburg S, Weggelaar I, van Oijen MG, Drenth JP. Optimal length of antiviral therapy in patients with hepatitis C virus genotypes 2 and 3: a meta-analysis. *Antivir Ther* 2009;14:1139-48. ([Abstract](#))
- Snoeck E, Wade JR, Duff F, Lamb M, Jorga K. Predicting sustained virological response and anaemia in chronic hepatitis C patients treated with peginterferon alfa-2a (40KD) plus ribavirin. *Br J Clin Pharmacol* 2006;62:699-709. ([Abstract](#))
- Soza A, Everhart JE, Ghany MG, et al. Neutropenia during combination therapy of interferon alfa and ribavirin for chronic hepatitis C. *Hepatology* 2002;36:1273-9. ([Abstract](#))
- Sulkowski MS, Poordad F, Manns MP, et al. Anemia during treatment with peginterferon alfa-2b/ribavirin with or without boceprevir is associated with higher svr rates: analysis of previously untreated and previous-treatment-failure patients. *J Hepatol* 2011;54:S194-S195.
- Suppiah V, Moldovan M, Ahlenstiel G, et al. IL28B is associated with response to chronic hepatitis C interferon-alpha and ribavirin therapy. *Nat Genet* 2009;41:1100-4. ([Abstract](#))
- Svensson JO, Bruchfeld A, Schvarcz R, Stahle L. Determination of ribavirin in serum using highly selective solid-phase extraction and high-performance liquid chromatography. *Ther Drug Monit* 2000;22:215-8. ([Abstract](#))
- Swain MG, Lai MY, Shiffman ML, et al. A sustained virologic response is durable in patients with chronic hepatitis C treated with peginterferon alfa-2a and ribavirin. *Gastroenterology* 2010;139:1593-601. ([Abstract](#))
- Tanaka Y, Nishida N, Sugiyama M, et al. Genome-wide association of IL28B with response to pegylated interferon-alpha and ribavirin therapy for chronic hepatitis C. *Nat Genet* 2009;41:1105-9. ([Abstract](#))

- Tandon P, Doucette K, Fassbender K, Vandermeer B, Durec T, Dryden DM. Granulocyte colony-stimulating factor for hepatitis C therapy-associated neutropenia: systematic review and economic evaluation. *J Viral Hepat* 2011;18:e381-93. ([Abstract](#))
- Terrault NA. Prophylactic and preemptive therapies for hepatitis C virus-infected patients undergoing liver transplantation. *Liver Transpl* 2003;9:S95-S100. ([Abstract](#))
- Thomas DL, Thio CL, Martin MP, et al. Genetic variation in IL28B and spontaneous clearance of hepatitis C virus. *Nature* 2009;461:798-801. ([Abstract](#))
- Thompson AJ, Patel K, Chuang WL, et al. Viral clearance is associated with improved insulin resistance in genotype 1 chronic hepatitis C but not genotype 2/3. *Gut* 2012;61:128-34. ([Abstract](#))
- Tillmann HL, Thompson AJ, Patel K, et al. A polymorphism near IL28B is associated with spontaneous clearance of acute hepatitis C virus and jaundice. *Gastroenterology* 2010;139:1586-92. ([Abstract](#))
- Todros L, Saracco G, Durazzo M, et al. Efficacy and safety of interferon alfa therapy in chronic hepatitis C with autoantibodies to liver-kidney microsomes. *Hepatology* 1995;22:1374-8. ([Abstract](#))
- Tran HA, Jones TL, Ianna EA, Reeves GE. The natural history of interferon-alpha induced thyroiditis in chronic hepatitis c patients: a long term study. *Thyroid Res* 2011;4:2. ([Abstract](#))
- Veldt BJ, Heathcote EJ, Wedemeyer H, et al. Sustained virologic response and clinical outcomes in patients with chronic hepatitis C and advanced fibrosis. *Ann Intern Med* 2007;147:677-84. ([Abstract](#))
- Vertex Pharmaceuticals Incorporated. Prescribing Information Incivek (telaprevir). PDF, 23 pages, accessed February 25, 2012.
- Vierling JM, Flamm SL, Gordon SC, et al. Efficacy of boceprevir in prior null responders to peginterferon/ribavirin: the provide study. *Hepatology* 2011;54:796A-797A.
- Vogel W, Graziadei I, Umlauf F, et al. High-dose interferon-alpha2b treatment prevents chronicity in acute hepatitis C: a pilot study. *Dig Dis Sci* 1996;41:81S-85S. ([Abstract](#))
- Von Wagner M, Huber M, Berg T, et al. Peginterferon-alpha-2a (40KD) and ribavirin for 16 or 24 weeks in patients with genotype 2 or 3 chronic hepatitis C. *Gastroenterology* 2005;129:522-27. ([Abstract](#))
- Wesche B, Jaeckel E, Trautwein C, et al. Induction of autoantibodies to the adrenal cortex and pancreatic islet cells by interferon alpha therapy for chronic hepatitis C. *Gut* 2001;48:378-83. ([Abstract](#))
- Wiegand J, Buggisch P, Boecher W, et al. Early monotherapy with pegylated interferon alpha-2b for acute hepatitis C infection: the HEP-NET acute-HCV-II study. *Hepatology* 2006;43:250-6. ([Abstract](#))
- Willems B, Hadziyannis SJ, Morgan TR, et al. Increased SVR rate with 48 wks' treatment and higher RBV dose in HCV genotype 2/3 pts without a rapid virologic response (Rvr) treated with peginterferon alfa-2a (40KD) (Pegasys (R)) plus RBV (Copegus (R)). *Gastroenterology* 2007;132:A728-A728.
- Younossi ZM, Nader FH, Bai C, et al. A phase II dose finding study of darbepoetin alpha and filgrastim for the management of anaemia and neutropenia in chronic hepatitis C treatment. *J Viral Hepat* 2008;15:370-8. ([Abstract](#))
- Zeuzem S, Andreone P, Pol S, et al. Telaprevir for retreatment of HCV infection. *N Engl J Med* 2011;364:2417-28. ([Abstract](#))
- Zeuzem S, Buti M, Ferenci P, et al. Efficacy of 24 weeks treatment with peginterferon alfa-2b plus ribavirin in patients with chronic hepatitis C infected with genotype 1 and low pretreatment viremia. *J Hepatol* 2006;44:97-103. ([Abstract](#))
- Zeuzem S, Diago M, Gane E, et al. Peginterferon alfa-2a (40 kilodaltons) and ribavirin in patients with chronic hepatitis C and normal aminotransferase levels. *Gastroenterology* 2004a;127:1724-32. ([Abstract](#))
- Zeuzem S, Hultcrantz R, Bourliere M, et al. Peginterferon alfa-2b plus ribavirin for treatment of chronic hepatitis C in previously untreated patients infected with HCV genotypes 2 or 3. *J Hepatol* 2004b;40:993-9. ([Abstract](#))
- Zignego AL, Ferri C, Pileri SA, Caini P, Bianchi FB. Extrahepatic manifestations of Hepatitis C Virus infection: a general overview and guidelines for a clinical approach. *Dig Liver Dis* 2007;39:2-17. ([Abstract](#))

# 14. Hepatitis C: New Drugs

*Christian Lange, Christoph Sarrazin*

## Introduction

Combination therapy with pegylated interferon- $\alpha$  plus weight-based ribavirin leads to sustained virologic response (SVR, defined by undetectable HCV RNA 24 weeks after treatment completion) in approximately 50% of all HCV genotype 1-infected patients, compared to 70-90% of patients infected with HCV genotypes 2 and 3 (Zeuzem 2009). The limited treatment success of this treatment especially in HCV genotype 1 patients, the long treatment durations (up to 72 weeks), as well as the numerous side-effects of PEG-IFN  $\alpha$  and ribavirin therapy, and an exploding knowledge of the HCV life cycle and of structural features of the HCV proteins, has spurred the development of many promising directly acting antiviral agents (DAA) (Kim 1996, Lindenbach 2005, Lohmann 1999, Lorenz 2006, Wakita 2005). In principle, each of the four HCV structural and six non-structural proteins, HCV-specific RNA structures such as the IRES, as well as host factors on which HCV depends, are suitable targets for DAA agents. In the following section, DAA compounds currently in clinical development are presented (Table 1, Figure 1).

**Table 1. Selected directly acting antiviral agents in the pipeline.**

Drug name	Company	Target / Active site	Phase
<b>NS3-4A protease inhibitors</b>			
Ciluprevir (BILN 2061)	Boehringer Ingelheim	Active site / macrocyclic	Stopped
Telaprevir (VX-950)	Vertex / Janssen	Active site / linear	IV
Boceprevir (SCH503034)	Merck (S-P)	Active site / linear	IV
Simeprevir (TMC435350)	Janssen / Medivir	Active site / macrocyclic	III
Danoprevir (R7227)	Roche / InterMune	Active site / macrocyclic	II
Vaniprevir (MK-7009)	Merck	Active site / macrocyclic	Halted/II
MK-5172	Merck	Active site / macrocyclic	II
BI201335	Boehringer Ingelheim	Active site / linear	III
Narlaprevir (SCH900518)	Schering-Plough	Active site / linear	Halted
Asunaprevir (BMS-650032)	Bristol-Myers Squibb	Active site	II
PHX1766	Phenomix	Active site	I
GS-9256	Gilead	Active site	II

Drug name	Company	Target / Active site	Phase
GS-9451	Gilead	Active site	I
ABT450	Abbott	Active site	II
IDX320	Idenix	Active site	II
ACH-1625	Achillion	Active site / macrocyclic?	II
<b>Nucleoside analog NS5B polymerase inhibitors</b>			
Valopicitabine (NM283)	Idenix / Novartis	Active site	Stopped
Mericitabine (R7128)	Roche / Pharmasset	Active site	II
R1626	Roche	Active site	Stopped
PSI-7977	Pharmasset	Active site	II
PSI-938	Pharmasset	Active site	II
IDX184	Idenix	Active site	II
<b>Non-nucleoside NS5B polymerase inhibitors (NNI)</b>			
BILB 1941	Boehringer Ingelheim	NNI site 1 / thumb 1	Stopped
BI207127	Boehringer Ingelheim	NNI site 1 / thumb 1	II
MK-3281	Merck	NNI site 1 / thumb 1	II
TMC647055	Janssen	NNI site 1 / thumb 1	
Filibuvir (PF-00868554)	Pfizer	NNI site 2 / thumb 2	II
VCH759	ViroChem Pharma	NNI site 2 / thumb 2	II
VCH916	ViroChem Pharma	NNI site 2 / thumb 2	II
VCH222	ViroChem Pharma	NNI site 2 / thumb 2	II
ANA598	Anadys	NNI site 3 / palm 1	II
ABT-072	Abbott	NNI site 3 / palm 1	II
ABT-333	Abbott	NNI site 3 / palm 1	II
HCV-796	ViroPharma / Wyeth	NNI site 4 / palm 2	Stopped
GS-9190	Gilead	NNI site 4 / palm 2	II
IDX375	Idenix	NNI site 4 / palm 2	II
<b>NS5A inhibitor</b>			
Daclatasvir (BMS-790052)	Bristol-Myers Squibb	NS5A domain 1 inhibitor	II
BMS-824393	Bristol-Myers Squibb	NS5A protein	I
PPI-461	Presidio Pharmaceuticals	NS5A protein	I
GS-5885	Gilead	NS5A protein	I
<b>Indirect inhibitors / unknown mechanism of action</b>			
Alisporivir (Debio-025)	Debiopharm	Cyclophilin inhibitor	III
NIM811	Novartis	Cyclophilin inhibitor	I
SCY-635	Scynexis	Cyclophilin inhibitor	II
Nitazoxanide		PKR induction (?)	II
Miravirsen	Santaris	miRNA122 antisense RNA	II
Celgosivir	Migenix	A-glucosidase inhibitor	II

## HCV life cycle and treatment targets

HCV is a positive-sense single-stranded RNA virus of approximately 9600 nucleotides. The HCV genome contains a single large open reading frame encoding for a polyprotein of about 3100 amino acids. From this initially translated polyprotein, the structural HCV protein core (C) and envelope glycoproteins 1 and 2 (E1, E2); p7; and the six non-structural HCV proteins NS2, NS3, NS4A, NS4B, NS5A and NS5B, are processed by both viral and host proteases. The core protein forms the viral nucleocapsid carrying E1 and E2, which are receptors for viral attachment and host cell entry. The non-structural proteins are multifunctional



proteins essential for the HCV life cycle (Bartenschlager 2004). P7 is a small hydrophobic protein that oligomerises into a circular hexamer, most likely serving as an ion channel through the viral lipid membrane. The large translated section of the HCV genome is flanked by the strongly conserved HCV 3' and 5' untranslated regions (UTR). The 5'UTR is comprised of four highly structured domains forming the internal ribosome entry site (IRES), which plays an important role in HCV replication (Figure 2).

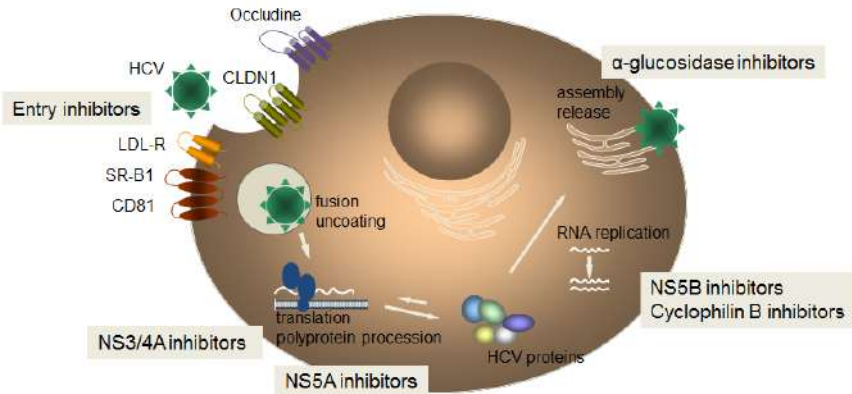
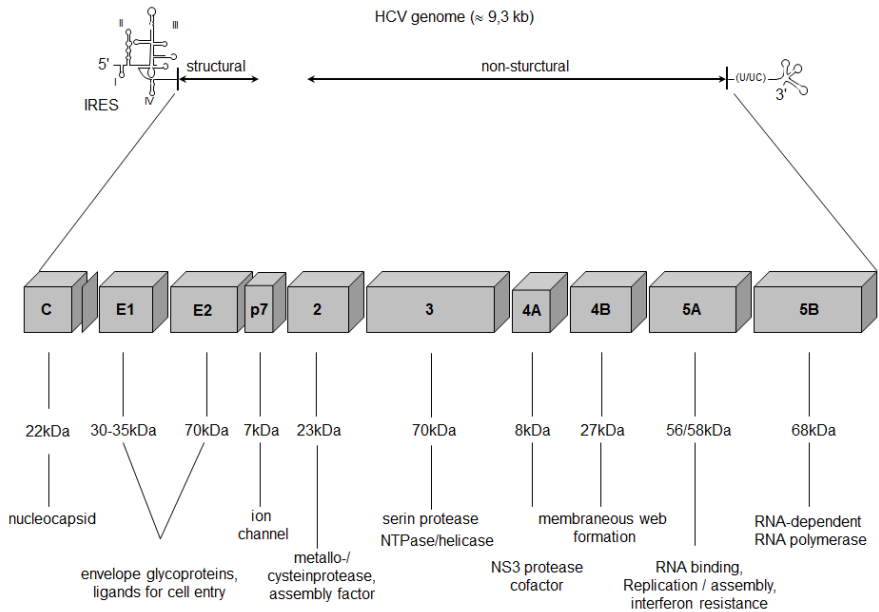


Figure 1. HCV life cycle and targets for directly acting antiviral (DAA) agents.

## NS3-4A protease inhibitors

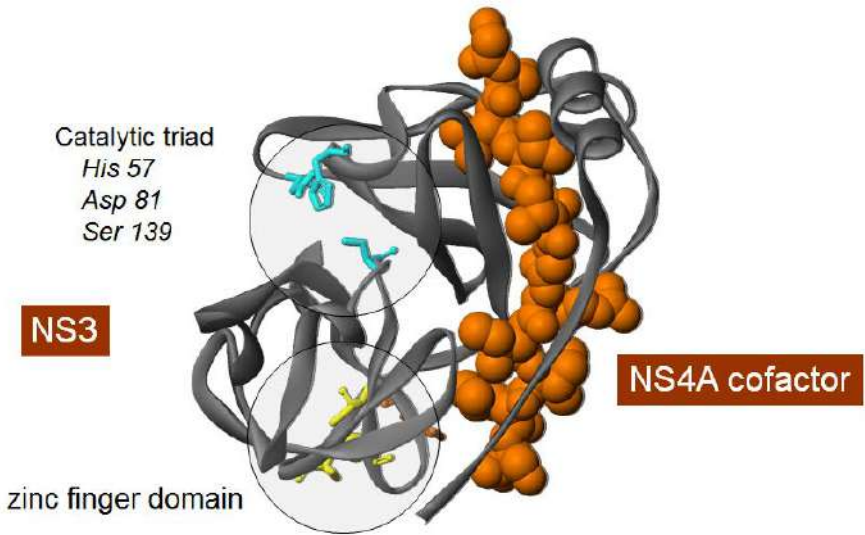
### Molecular biology

After receptor-mediated endocytosis, the fusion of HCV with cellular membranes, and uncoating the viral nucleocapsid, the single-stranded positive-sense RNA genome of the virus is released into the cytoplasm to serve as a messenger RNA for the HCV polyprotein precursor. HCV mRNA translation is under the control of the internal ribosome entry site (IRES), formed by domains II-IV of the HCV 5'UTR (Moradpour 2007). IRES mediates HCV polyprotein translation by forming a stable complex with the 40S ribosomal subunit, eukaryotic initiation factors and viral proteins.



**Figure 2. Genomic organisation of HCV.**

From the initially translated HCV polyprotein the three structural and seven non-structural HCV proteins are processed by both host and viral proteases (Moradpour 2007). NS2 is a metalloproteinase that cleaves itself from the NS2/NS3 protein, leading to its own loss of function and to the release of the NS3 protein (Lorenz 2006). NS3 provides a serine protease activity and a helicase/NTPase activity. The serine protease catalytic triad – histidine 57, asparagine 81 and serine 139 – is located in a small groove between the two b-barrels (Kim 1996, Kim 1998). NS3 forms a tight, non-covalent complex with its obligatory cofactor and enhancer NS4A, which is essential for proper protein folding (Figure 3). The NS3-4A protease cleaves the junctions between NS3/NS4A, NS4A/NS4B, NS4B/NS5A and NS5A/NS5B. Besides its essential role in protein processing, NS3 is integrated into the HCV RNA replication complex, supporting the unwinding of viral RNA by its helicase activity. Moreover, NS3 might play an important role in HCV persistence via blocking TRIF-mediated toll-like receptor signalling and Cardif-mediated RIG-I signalling, subsequently resulting in impaired induction of type I interferons (Meylan 2005). Thus, pharmacologic NS3 inhibition might support viral clearance by restoring the innate immune response.

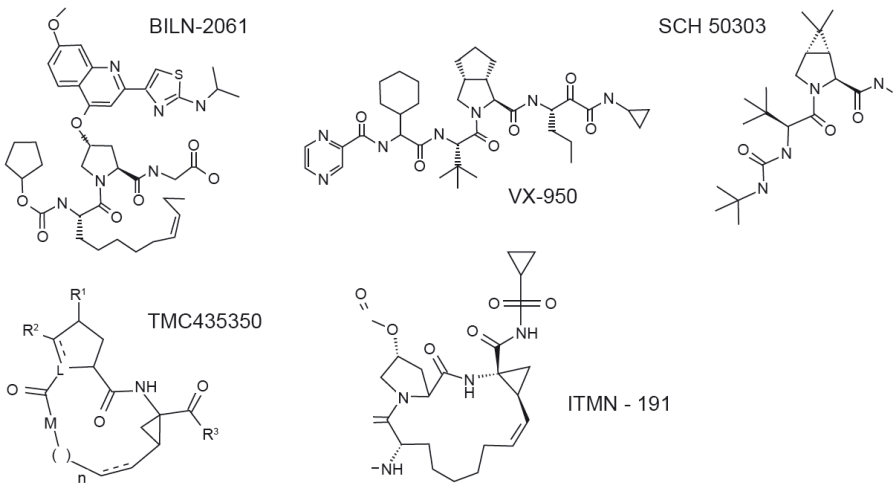


**Figure 3. Molecular structure of the HCV NS3-4A protease.**

The active site of the NS3-4A protease is located in a shallow groove between the two  $\beta$ -barrels of the protease making the design of compound inhibitors relatively difficult. Nevertheless, many NS3-4A protease inhibitors have been developed which can be divided into two classes, the macrocyclic inhibitors and linear tetrapeptide  $\alpha$ -ketoamide derivatives. In general, NS3-4A protease inhibitors have been shown to strongly inhibit HCV replication during monotherapy, but also may cause the selection of resistant mutants, which is followed by viral breakthrough. The additional administration of pegylated interferon and ribavirin, however, was shown to reduce the frequency of development of resistance. Future strategies aim for combination therapies with different antiviral drugs to prevent the development of resistance. The most advanced compounds are telaprevir and boceprevir, both approved in 2011.

### **Ciluprevir (BILN 2061)**

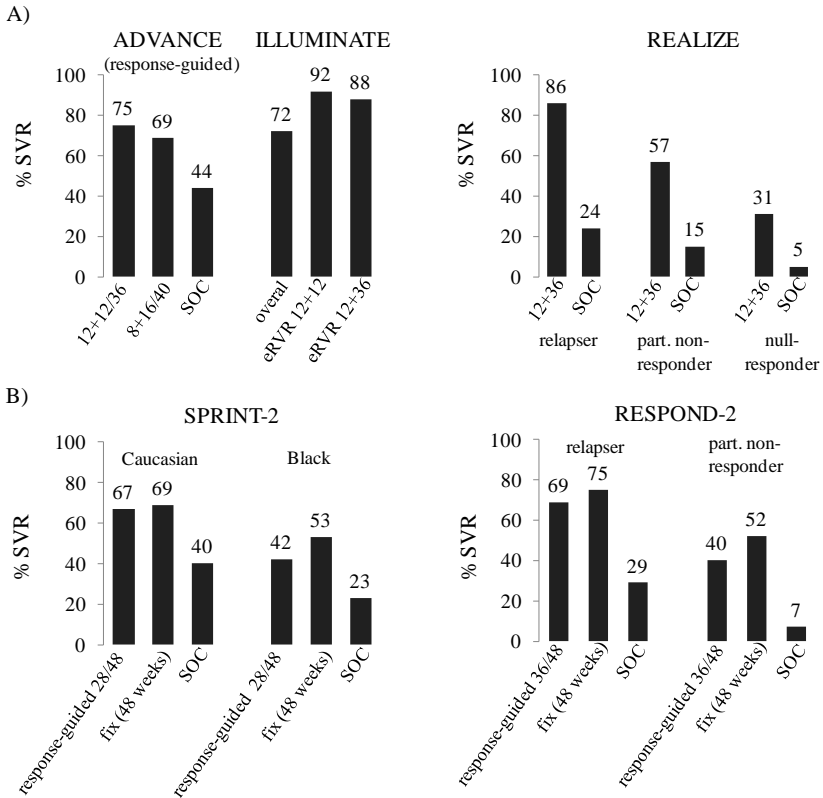
The first clinically tested NS3-4A inhibitor was ciluprevir (BILN 2061), an orally bioavailable, peptidomimetic, macrocyclic drug binding non-covalently to the active center of the enzyme (Lamarre 2003) (Figure 4). Ciluprevir monotherapy was evaluated in a double-blind, placebo-controlled pilot study in treatment-naïve genotype 1 patients with liver fibrosis and compensated liver cirrhosis (Hinrichsen 2004). Ciluprevir, administered twice daily for two days at doses ranging from 25 to 500 mg, led to a mean 2-3  $\log_{10}$  decrease of HCV RNA serum levels in most patients. Importantly, the stage of disease did not affect the antiviral efficacy of ciluprevir. The tolerability and efficacy of ciluprevir in HCV genotype 2- and 3-infected individuals was examined in an equivalent study design, but compared to genotype 1 patients, the antiviral activity was less pronounced and more variable in these patients (Reiser 2005). Ciluprevir development has been halted.



**Figure 4. Molecular structure of selected NS3-4A inhibitors.**

## Telaprevir (Incivek/Incivo<sup>®</sup>) and boceprevir (Victrelis<sup>®</sup>)

Telaprevir and boceprevir were approved for the treatment of chronic hepatitis C virus genotype 1 infection by the FDA, EMA and several other countries in 2011. Both telaprevir and boceprevir are orally bioavailable, peptidomimetic NS3-4A protease inhibitors belonging to the class of  $\alpha$ -ketoamid derivatives (Figure 4). Like other NS3-4A inhibitors, telaprevir and boceprevir are characterized by a remarkable antiviral activity against HCV genotype 1. However, monotherapy with these agents results in the rapid selection of drug-resistant variants followed by viral breakthrough (Reesink 2006, Sarrazin 2007). Phase II and III clinical studies have shown that the addition of pegylated interferon  $\alpha$  plus ribavirin leads to a substantially reduced frequency of resistant mutants and viral breakthrough, and to significantly higher SVR rates in both treatment-naïve and treatment-experienced HCV genotype 1 patients compared to treatment with pegylated interferon  $\alpha$  and ribavirin alone (Bacon 2011, Jacobson 2011, Poordad 2011, Sherman 2011, [Zeuzem 2011](#)). Therefore, telaprevir- and boceprevir-based triple therapy can be considered the novel standard of care for HCV genotype 1 patients. Results of the Phase III telaprevir and boceprevir approval studies are summarized in Figure 5.



**Figure 5. SVR rates in Phase III clinical trials evaluating telaprevir (A) or boceprevir (B) in combination with PEG-IFN  $\alpha$  and ribavirin.** ADVANCE, ILLUMINATE and SPRINT-2 enrolled treatment-naïve patients, REALIZE and RESPOND-2 enrolled treatment-experienced patients. Telaprevir was administered for 8 or 12 weeks in combination with PEG-IFN  $\alpha$ -2a and ribavirin, followed by 12-40 weeks of PEG-IFN  $\alpha$ -2a and ribavirin alone. Boceprevir was administered over the whole treatment period of 28 or 48 weeks in combination with PEG-IFN  $\alpha$ -2b and ribavirin, except of the first 4 weeks of lead-in therapy of PEG-IFN  $\alpha$ -2b and ribavirin only. eRVR, extended early virologic response; SOC, standard of care; LI, lead-in (4 weeks of PEG-IFN  $\alpha$  plus ribavirin only).

## Other NS3 protease inhibitors

Other NS3 protease inhibitors are currently in various phases of development (danoprevir (R7227/ITMN191), vaniprevir (MK-7009), BI201335, simeprevir (TMC435350), narlaprevir (SCH900518), asunaprevir (BMS-650032), PHX1766, ACH-1625, IDX320, ABT-450, MK-5172, GS-9256, GS-9451) and will significantly increase treatment options for chronic hepatitis C in the near future. In general, comparable antiviral activities to telaprevir and boceprevir in HCV genotype 1 infected patients were observed during mono- (and triple-) therapy studies (Brainard 2010, Manns 2011, Reesink 2010). Potential advantages of these second and third generation protease inhibitors might be improved tolerability, broader genotypic activity, different resistance profiles, and/or improved pharmacokinetics for once-daily dosage (e.g., TMC435, BI201335). Different

resistance profiles between linear tetrapeptide and macrocyclic inhibitors binding to the active site of the NS3 protease have been revealed. However, R155 is the main overlapping position for resistance and different mutations at this amino acid site within the NS3 protease confer resistance to nearly all protease inhibitors currently in advanced clinical development (Sarrazin 2010). An exception is MK-5172, which exhibits potent antiviral activity against variants carrying mutations at position R155. In addition, MK-5172 had potent antiviral activity against both HCV genotype 1 and 3 isolates (Brainard 2010).

### Resistance to NS3-4A inhibitors

Because of the high replication rate of HCV and the poor fidelity of its RNA-dependent RNA polymerase, numerous variants (quasispecies) are continuously produced during HCV replication. Among them, variants carrying mutations altering the conformation of the binding sites of DAA compounds can develop. During treatment with specific antivirals, these preexisting drug-resistant variants have a fitness advantage and can be selected to become the dominant viral quasispecies. Many of these resistant mutants exhibit an attenuated replication with the consequence that, after termination of exposure to specific antivirals, the wild type may displace the resistant variants (Sarrazin 2007). Nevertheless, HCV quasispecies resistant to NS3-4A protease inhibitors or non-nucleoside polymerase inhibitors can be detected at low levels in some patients (approx. 1%) who have never been treated with these specific antivirals before (Gaudieri 2009). The clinical relevance of these pre-existing mutants is not completely understood, although there is evidence that they may reduce the chance of achieving an SVR with DAA-based triple therapies if the patient's individual sensitivity to pegylated interferon  $\alpha$  + ribavirin is low.

More recently, the Q80R/K variant has been described as conferring low-level resistance to simeprevir (TMC435), a macrocyclic protease-inhibitor. Interestingly, the Q80K variant can be detected in approximately 10% of HCV genotype 1-infected patients (typically in subtype 1a isolates) and a slower viral decline during simeprevir-based triple therapy was observed (Lenz 2011). Table 2 summarizes the resistance profile of selected NS3-4A inhibitors. Although the resistance profiles differ significantly, R155 is an overlapping position for resistance development and different mutations at this position confer resistance to nearly all protease inhibitors (not MK-5172) currently in advanced clinical development (Sarrazin 2010). Importantly, many resistance mutations could be detected *in vivo* only by clonal sequencing. For example, mutations at four positions conferring telaprevir resistance have been characterized so far (V36A/M/L, T54A, R155K/M/S/T and A156S/T), but only A156 could be identified initially *in vitro* in the replicon system (Lin 2005). These mutations, alone or as double mutations, conferred low (V36A/M, T54A, R155K/T, A156S) to high (A156T/V, V36M + R155K, V36M + 156T) levels of resistance to telaprevir (Sarrazin 2007). It is thought that the resulting amino acid changes of these mutations alter the conformation of the catalytic pocket of the protease, which impedes binding of the protease inhibitor (Welsch 2008).

**Table 2. Resistance mutations to HCV NS3 protease inhibitors.**

	36	54	55	80	155	156A	156B	168	170
Telaprevir* (linear)	■	■			■	■	■		
Boceprevir* (linear)	■	■	■		■	■			■
SCH900518* (linear)	■	■			■	■	■		■
BI-201335* (linear?)					■			■	
BILN-2061 ** (macrocylic)					■		■	■	
Danoprevir* (macrocylic)					■			■	
MK-7009* (macrocylic)					■		■	■	
TMC435* (macrocylic)				■	■		■		
BMS-650032* (macrocylic)				■	■			■	
GS-9451* (macrocylic)					■			■	
ABT450* (macrocylic)					■			■	
IDX320** (macrocylic)								■	
ACH1625** (macrocylic)								■	
MK-5172*** (macrocylic)								■	

36: V36A/M; 54: T54S/A; 55: V55A; 80: Q80R/K; 155: R155K/T/Q; 156A: A156S; 156B: A156T/V; 168: D168A/V/T/H; 170: V170A/T

\* mutations associated with resistance in patients

\*\* mutations associated with resistance *in vitro*

\*\*\* no viral break-through during 7 days monotherapy

# Q80 variants have been observed in approximately 10% of treatment-naïve patients and was associated with slower viral decline during simeprevir (TMC435) triple therapy

As shown for other NS3-4A protease inhibitors as well (e.g., danoprevir), the genetic barrier to telaprevir resistance differs significantly between HCV subtypes. In all clinical studies of telaprevir alone or in combination with PEG-IFN  $\alpha$  and ribavirin, viral resistance and breakthrough occurred much more frequently in patients infected with HCV genotype 1a compared to genotype 1b. This difference was shown to result from nucleotide differences at position 155 in HCV subtype 1a (aga, encodes R) versus 1b (cga, also encodes R). The mutation most frequently associated with resistance to telaprevir is R155K; changing R to K at position 155 requires 1 nucleotide change in HCV subtype 1a, and 2 nucleotide changes in subtype 1b isolates (McCown 2009).

It will be important to define whether treatment failure due to the development of variants resistant to DAA agents has a negative impact on re-treatment with the same or a different DAA treatment regimen. Follow-up studies of telaprevir and

boceprevir Phase III studies have revealed a rapid decline of resistant variants below the limit of detection (>20% of quasispecies) of population sequencing techniques (Barnard 2011, Sherman 2011). However, telaprevir- and boceprevir-resistant variants were detectable by a clonal sequencing approach several years after treatment in single patients who had been treated with telaprevir or boceprevir within smaller Phase Ib studies (Susser 2011).

## NS5B polymerase inhibitors

### Molecular biology

HCV replication is initiated by the formation of the replication complex, a highly structured association of viral proteins and RNA, of cellular proteins and cofactors, and of rearranged intracellular lipid membranes derived from the endoplasmic reticulum (Moradpour 2007). The key enzyme in HCV RNA replication is NS5B, an RNA-dependent RNA polymerase that catalyzes the synthesis of a complementary negative-strand RNA by using the positive-strand RNA genome as a template (Lesburg 1999) (Figure 6). From this newly synthesized negative-strand RNA, numerous RNA strands of positive polarity are produced by NS5B activity that serve as templates for further replication and polyprotein translation. Because of poor fidelity leading to a high rate of errors in its RNA sequencing, numerous different isolates are generated during HCV replication in a given patient, termed HCV quasispecies. It is reasoned that due to the lack of proofreading of the NS5B polymerase together with the high replication of HCV, every possible mutation is generated each day.

NS5B RNA polymerase inhibitors can be divided into two distinct categories. Nucleoside analog inhibitors (NIs) like valopicitabine (NM283), mericitabine (R7128), R1626, PSI-7977, PSI-938 or IDX184 mimic the natural substrates of the polymerase and are incorporated into the growing RNA chain, thus causing direct chain termination by tackling the active site of NS5B (Koch 2006). Because the active centre of NS5B is a highly conserved region of the HCV genome, NIs are potentially effective against different genotypes. Single amino acid substitutions in every position of the active centre may result in loss of function or in extremely impaired replicative fitness. Thus, there is a relatively high barrier in the development of resistances to NIs.

In contrast to NIs, the heterogeneous class of non-nucleoside inhibitors (NNIs) achieves NS5B inhibition by binding to different allosteric enzyme sites, which results in conformational protein change before the elongation complex is formed (Beaulieu 2007). For allosteric NS5B inhibition high chemical affinity is required. NS5B is structurally organized in a characteristic “right hand motif”, containing finger, palm and thumb domains, and offers at least four NNI-binding sites, a benzimidazole-(thumb 1)-, thiophene-(thumb 2)-, benzothiadiazine-(palm 1)- and benzofuran-(palm 2)-binding site (Lesburg 1999) (Figure 6). Because of their distinct binding sites, different polymerase inhibitors can theoretically be used in combination or in sequence to manage the development of resistance. Because NNIs bind distantly to the active centre of NS5B, their application may rapidly lead to the development of resistant mutants *in vitro* and *in vivo*. Moreover, mutations at the NNI binding sites do not necessarily lead to impaired function of the enzyme. Figure 7 shows the structure of selected nucleoside and non-nucleoside inhibitors.



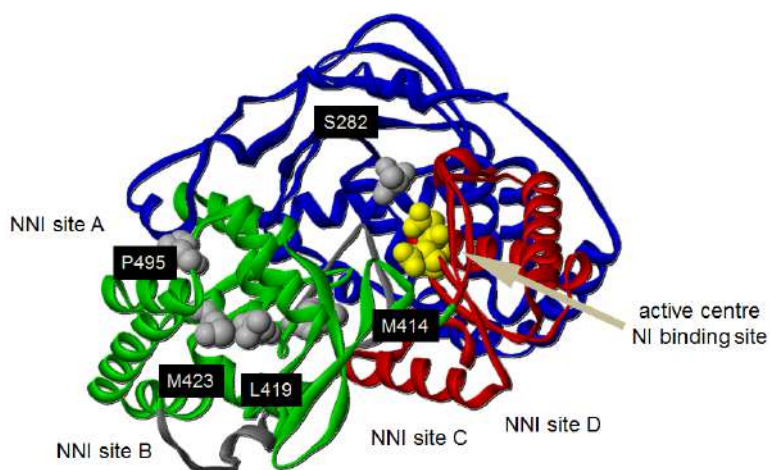


Figure 6. Structure of the HCV NS5B RNA polymerase and binding sites.

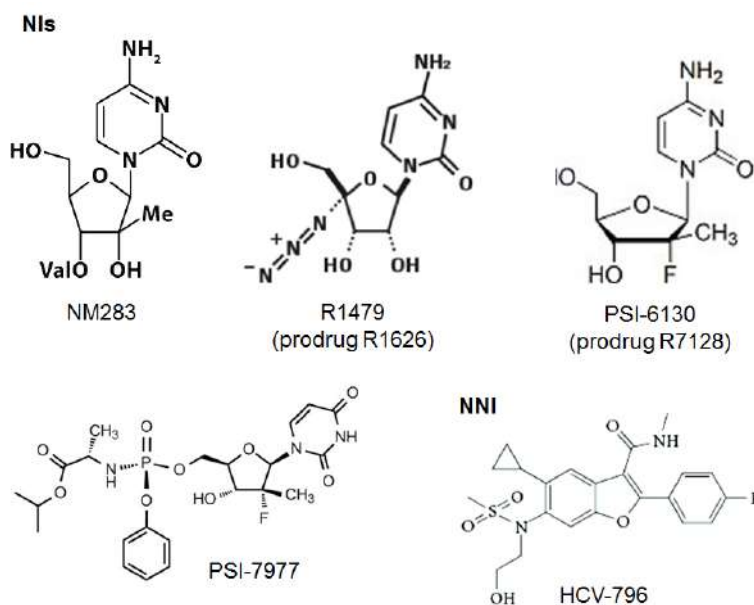


Figure 7. Molecular structure of selected NS5B polymerase inhibitors.

## Nucleoside analogs

Valopicitabine (NM283, 2'-C-methylcytidine/NM107), the first nucleoside inhibitor investigated in patients with chronic hepatitis C, showed a low antiviral activity

(Afdhal 2007). Due to gastrointestinal side effects the clinical development of NM283 was stopped.

The second nucleoside inhibitor to be reported in patients with chronic hepatitis C was R1626 (4'-azidocytidine/PSI-6130). A Phase 1 study in genotype 1-infected patients observed a high antiviral activity at high doses of R1626 in genotype 1-infected patients (Pockros 2008). No viral breakthrough with selection of resistant variants was reported from monotherapy or combination studies with pegylated interferon  $\pm$  ribavirin (Pockros 2008). Due to severe lymphopenia and infectious disease adverse events further development of R1626 was stopped.

Mericitabine (RG7128) is still in development and the most advanced nucleoside polymerase inhibitor. Mericitabine is safe and well-tolerated, effective against all HCV genotypes, and thus far no viral resistance against mericitabine has been observed in clinical studies. Interim results of current Phase II clinical trials in HCV genotype 1-, 2-, 3-infected patients of R7128 in combination with pegylated interferon and ribavirin revealed superior SVR rates of mericitabine-based triple therapy compared to PEG-IFN  $\alpha$  alone (Pockros 2011). In an all oral regimen, administration of R7128 in combination with the protease inhibitor R7227/ITMN191 for 14 days, a synergistic antiviral activity of both drugs was observed (Gane 2010). No viral breakthrough with selection of resistant variants has been reported.

Very promising clinical data have been published recently for PSI-7977, a nucleoside analog NS5B inhibitor effective against all HCV genotypes. In HCV genotype 2- and 3- infected patients, PSI-7977 (400 mg once daily) in combination with ribavirin for 12 weeks + PEG-IFN  $\alpha$  for 4-12 weeks resulted in 100% RVR and 100% week 12 SVR rates (Gane 2011). No PSI-7977-associated side effects have been reported, and no virologic breakthrough has been observed. A second study evaluated PSI-7977-based triple therapy in treatment-naïve HCV genotype 1-infected patients. In this study, PSI-7977 was administered for 12 weeks, together with PEG-IFN  $\alpha$  and ribavirin for 24 or 48 weeks in total, according to whether HCV RNA was below the limit of detection at treatment weeks 4 and 12 or not, respectively (Lawitz 2011). Most patients were eligible for the shortened treatment duration of 24 weeks, and SVR was achieved in approximately 90% of all patients.

Other nucleoside analogs (e.g., PSI-938 and IDX184) are at earlier stages of clinical development (Sarrazin 2010).

Overall, the newer nucleoside analogs (PSI-7977, PSI-938) also demonstrate high antiviral activities that, together with their high genetic barrier to resistance, suggest that they are optimal candidates for all-oral combination therapies (see below).

## Non-nucleoside analogs

At least 4 different allosteric binding sites have been identified for inhibition of the NS5B polymerase by non-nucleoside inhibitors. Currently, numerous non-nucleoside inhibitors are in Phase I and II clinical evaluation (e.g., NNI site 1 inhibitor BI207127; NNI site 2 inhibitors filibuvir (PF-00868554), VCH-759, VCH-916 and VCH-222; NNI site 3 inhibitor ANA598, NNI site 4 inhibitors HCV-796, and ABT-333) (Ali 2008, Cooper 2007, Erhardt 2009, Kneteman 2009). In general, these non-nucleoside analogs display a low to medium antiviral activity and a low genetic barrier to resistance, evidenced by frequent viral breakthrough during monotherapy studies and selection of resistance mutations at variable sites of the

enzyme. In line with these experiences in Phase I studies, a Phase II triple therapy study with filibuvir in combination with pegylated interferon and ribavirin showed high relapse and relative low SVR rates (Jacobson 2010). In contrast to nucleoside-analogs, non-nucleoside analogs in general do not display antiviral activity against different HCV genotypes (Sarrazin 2010). Due to their low antiviral efficacy and low genetic barrier to resistance, non-nucleoside analogs will probably not be developed as part of triple therapy but rather as components of quadruple or all-oral regimens (see below).

## NS5A inhibitors

The HCV NS5A protein seems to play a manifold role in HCV replication, assembly and release (Moradpour 2007). It was shown that NS5A is involved in the early formation of the replication complex by interacting with intracellular lipid membranes, and it initiates viral assembly at the surface of lipid droplets together with the HCV core (Shi 2002). NS5A may also serve as a channel that helps to protect and direct viral RNA within the membranes of the replication complex (Tellinghuisen 2005). Moreover, it was demonstrated that NS5A is able to interact with NS5B, which results in an enhanced activity of the HCV RNA polymerase. Besides its regulatory impact on HCV replication, NS5A has been shown to modulate host cell signaling pathways, which has been associated with interferon resistance (Wohnsland 2007). Furthermore, mutations within the NS5A protein have been clinically associated with resistance / sensitivity to IFN-based antiviral therapy (Wohnsland 2007).

BMS-790052 was the first NS5A inhibitor to be clinically evaluated. Even low doses of BMS-790052 display high antiviral efficacy against all HCV genotypes *in vitro*. Monotherapy with BMS-790052 led to a sharp initial decline of HCV RNA concentrations, though its genetic barrier to resistance is relatively low (Gao 2010). According to an interim analysis of a Phase IIb clinical trial in treatment-naïve HCV genotype 1 and 4 patients, treatment with 20 or 60 mg BMS-790052 once daily in combination with PEG-IFN  $\alpha$  and ribavirin for 24 or 28 weeks, 54% of all patients achieved an extended RVR, compared to 13% in the control group (Hezode 2011). SVR rates of this study are awaited.

During monotherapy, rapid selection of variants resistant to BMS-790052 occurred (Nettles 2011). The most common resistance mutations in HCV genotype 1a patients were observed at residues M28, Q30, L31, and Y93 of NS5A. In HCV genotype 1b patients, resistance mutations were observed less frequently, predominantly at positions L31 and Y93. These resistance mutations increased the EC<sub>50</sub> to BMS-790052 moderately to strongly (Fridell 2011). However, no cross-resistance between BMS-790052 and other DAA agents has been reported. Collectively, BMS-790052 is a highly promising agent for both triple therapy as well as all-DAA combination therapy approaches.

Other NS5A inhibitors (e.g., BMS-824393, PPI-461, GS-5885) are in early clinical development.

## Compounds targeting viral attachment and entry

The tetraspanin protein CD81, claudin-1, occludine, scavenger receptor class B type 1 (SR-B1), the low-density lipoprotein (LDL) receptor, glycosaminoglycans and the dendritic cell- /lymph node-specific intercellular adhesion molecule 3-grabbing non-integrin (DC-SIGN/L-SIGN) have been identified as putative ligands for E1 and E2 in the viral attachment and entry steps (Moradpour 2007). HCV entry inhibition might enrich future hepatitis C treatment opportunities, in particular in the prevention of HCV liver graft reinfection. HCV entry inhibition can be theoretically achieved by the use of specific antibodies or small molecule compounds either blocking E1 and E2 or their cellular receptors. So far, only results from clinical trials using polyclonal (e.g., civacir) (Davis 2005) or monoclonal (e.g., HCV-AB 68) (Schiano 2006) HCV-specific antibodies are available. The clinical benefit of these antibodies has been poor, however. The development of small molecule entry inhibitors is in a preclinical stage and is complicated by difficulties in the crystallographic characterization of HCV envelope proteins.

## Host factors as targets for treatment

### Cyclophilin B inhibitors

HCV depends on various host factors throughout its life cycle. Cyclophilin B is expressed in many human tissues and provides a cis-trans isomerase activity, which supports the folding and function of many proteins. Cyclophilin B enhances HCV replication by incompletely understood mechanisms, like the modulation of NS5B activity. Debio-025 (alisporivir) is an orally bioavailable cyclophilin B inhibitor exerting an antiviral impact on both HCV and HIV replication. In clinical trials in HIV- and HCV-coinfected patients, treatment with 1200 mg Debio-025 twice daily for two weeks led to a mean maximal  $\log_{10}$  reduction of HCV RNA of 3.6 and of HIV DNA of 1.0 (Flisiak 2008). Debio-025 was well-tolerated and no viral breakthrough occurred during the 14 days of treatment.

Combination therapy of Debio-025 200 mg, 600 mg or 1000 mg and PEG-IFN  $\alpha$ -2a was evaluated in a double-blind placebo-controlled Phase II trial in treatment-naïve patients monoinfected with HCV genotypes 1, 2, 3 or 4. Treatment was administered for 29 days. Mean  $\log_{10}$  reductions in HCV RNA at day 29 were 4.75 (1000 mg), 4.61 (600 mg) and 1.8 (200 mg) in the combination therapy groups compared to 2.49 (PEG-IFN  $\alpha$ -2a alone) and 2.2 (1000 mg Debio-025 alone) in the monotherapy groups. No differences in antiviral activity were observed between individuals infected with the different genotypes. Debio-025 was safe and well tolerated but led to a reversible bilirubin increase in some of the patients treated with 1000 mg Debio-025 daily (Flisiak 2009). A high genetic barrier to resistance of Debio-025 and a broad HCV genotypic activity highlight the potential of drugs targeting host proteins.

In a Phase II clinical trial in treatment-naïve HCV genotype 1 patients, combination therapy with Debio-025, PEG-IFN  $\alpha$ -2a and ribavirin for 24-48 weeks resulted in SVR rates of 69-76% compared to 55% in the control group (Flisiak 2011).

## Nitazoxanide

Nitazoxanide with its active metabolite tizoxanide is a thiazolide antiprotozoal approved for the treatment of *Giardia lamblia* and *Cryptosporidium parvum* infections. *In vitro* studies have revealed an essential inhibitory impact on HCV and HBV replication by still unknown mechanisms.

Results of two Phase 2 studies evaluating 500 mg nitazoxanide twice daily for 12 weeks followed by nitazoxanide, PEG-IFN  $\alpha$ -2a  $\pm$  RBV for 36 weeks yielded conflicting results with SVR rates of 79% in treatment-naïve genotype 4 patients, but of only 44% in HCV genotype 1 patients (Rossignol 2009). Additional studies are warranted to determine the role of nitazoxanide in the treatment of chronic hepatitis C.

## Silibinin

Silymarin, an extract of milk thistle (*Silybum marianum*) with antioxidant activity, has been empirically used to treat chronic hepatitis C and other liver diseases. Silibinin is one of the six major flavonolignans in silymarin. Surprisingly, recent reports demonstrated that silibinin inhibits HCV at various steps of its life cycle (Ahmed-Belkacem 2010, Wagoner 2010). In addition, intravenous silibinin in non-responders to prior IFN-based antiviral therapy led to a decline in HCV RNA between 0.55 to 3.02 log<sub>10</sub> IU/ml after 7 days and a further decrease after an additional 7 days in combination with PEG-IFN  $\alpha$ -2a/RBV in the range of 1.63 and 4.85 log<sub>10</sub> IU/ml (Ferenci 2008). Ongoing studies will clarify the role of silibinin in the treatment of chronic hepatitis C, including HCV liver graft reinfection.

## Miravirsen

MicroRNA-122 (miRNA-122) is a liver-specific microRNA that has been shown to be a critical host factor for HCV (Landford 2010). MiRNA-122 binds to the 5' NTR region of the HCV genome, which appears to be vital in the HCV replication process. Miravirsen is a modified antisense oligonucleotide that targets miRNA-122 and thereby prevents binding of miRNA-122 to the HCV genome. In a Phase IIa proof-of-principle study, weekly subcutaneous injections of miravirsen led to a reduction of HCV RNA serum concentration of up to 2.7 log<sub>10</sub> IU/mL, indicating that an antisense oligonucleotide-based approach of miRNA-122 inhibition could be a promising modality for antiviral therapy (Janssen 2010). No relevant side effects were seen in this study.

## Newer combination therapies

The approval of the HCV protease inhibitors telaprevir and boceprevir in 2011 constitutes a milestone in the treatment of chronic HCV genotype 1 infection. Nevertheless, telaprevir- or boceprevir-based triple therapy has certain limitations. In particular, treatment success still depends on the interferon-sensitivity of individual patients because a slow decline of HCV viral load during triple therapy is associated with a high risk of antiviral resistance development. Consequently, viral breakthrough of drug resistant variants was observed in a significant number of patients with partial or null response to previous treatment with PEG-IFN  $\alpha$  and ribavirin, in patients with limited decline of HCV viral load during lead-in treatment with PEG-IFN  $\alpha$  and ribavirin alone, or in difficult to cure populations like Blacks

or patients with advanced liver fibrosis. In addition, triple therapy is not an option for patients with contraindications to PEG-IFN  $\alpha$  or ribavirin, such as patients with decompensated liver cirrhosis or liver transplant failure.

To overcome these limitations, numerous trials have been initiated to investigate the potential of combination therapies with different DAA agents alone (Table 3). As is well established in the treatment of HIV infection, combining DAA agents with different antiviral resistance profiles should result in a substantially decreased risk of viral breakthrough of resistant variants. Nucleoside analog NS5B inhibitors plus drugs targeting host factors such as the cyclophilin inhibitor alisporivir display a high genetic barrier to resistance development and may therefore be key agents for effective DAA combination therapies (Sarrazin 2010). In contrast, NS3-4A and NS5A inhibitors display a low genetic barrier to resistance development, but in view of their high antiviral efficacy they appear to be promising combination partners for nucleoside analogs or cyclophilin inhibitors. Due to their low antiviral efficacy and low genetic barrier to resistance development, the role of non-nucleoside analog NS5B inhibitors is currently less clear. A potential advantage of non-nucleoside analogs is their binding to multiple target sites that may allow simultaneous treatment with several non-nucleoside analogs.

Currently, DAA combination treatment regimens can be classified according to the usage of PEG-IFN  $\alpha$  into quadruple therapy regimens and all-oral therapy regimens. Quadruple therapy approaches are based on therapy of PEG-IFN  $\alpha$  and ribavirin plus combination of two DAA agents from different classes. In contrast, all-oral treatment comprises interferon-free regimens including combinations of various DAA compounds with or without ribavirin.

### Quadruple therapy

Preliminary SVR data of a small but highly informative trial serves as a proof-of-concept for the potential of quadruple therapy approach for patients with previous null response to PEG-IFN  $\alpha$  + ribavirin (Lok 2011). In this Phase II study, 11 HCV genotype 1 patients with prior null response were treated with a combination of the NS5A inhibitor BMS-790052 and the protease inhibitor BMS-650032 together with PEG-IFN  $\alpha$  and ribavirin for 24 weeks. Quadruple therapy resulted in 100% SVR 12 weeks after treatment completion in both HCV genotype 1a- and 1b-infected patients. Even though the number of patients included in this trial was very limited, this high SVR rate after quadruple therapy seems impressive compared to SVR rates of ~30% that were achieved with telaprevir-based triple therapy in prior null responders (Zeuzem 2011).

A Phase II clinical trial assessed quadruple therapy with the non-nucleoside NS5B inhibitor tegobuvir in combination with the NS3-4A inhibitor GS-9256 + PEG-IFN  $\alpha$  and ribavirin for 28 days in treatment-naïve HCV genotype 1 patients (Zeuzem 2011). The primary endpoint of this study was rapid virologic response (RVR), which was achieved in 100% of patients. After 28 days of quadruple therapy, treatment with PEG-IFN  $\alpha$  and ribavirin was continued, which led to complete early virologic response (cEVR) in 94% of patients (Zeuzem 2011).

Another Phase II clinical trial investigated a response-guided approach during quadruple therapy containing the non-nucleoside NS5B inhibitor VX-222 (100 mg or 400 mg) in combination with the NS3-4A inhibitor telaprevir + PEG-IFN  $\alpha$  and ribavirin in treatment-naïve HCV genotype 1 patients (Nelson 2011). Quadruple

treatment was administered for 12 weeks. All treatment was stopped after 12 weeks in patients who were HCV RNA-negative at treatment weeks 2 and 8. Patients in whom HCV RNA was detectable at treatment week 2 or 8 received an additional 12 weeks of PEG-IFN  $\alpha$  and ribavirin alone. Up to 50% of patients met the criteria for the 12-week treatment duration. Of those, 82-93% achieved an SVR 12 weeks after treatment completion. In patients who were treated with an additional 12 weeks of PEG-IFN  $\alpha$  and ribavirin, the end-of-treatment response was 100%.

Collectively, the quadruple therapy approach appears to be highly promising in patients with limited sensitivity to interferon- $\alpha$ , even in patients with HCV subtype 1a.

### All-oral therapy without ribavirin

A first interferon-free clinical trial (the INFORM-1 study) evaluated the combination of a polymerase inhibitor (R7128) and an NS3 inhibitor (R7227/ITMN191). In this proof of principle study, patients were treated with both compounds for up to 2 weeks (Gane 2010). HCV RNA concentrations decreased by up to 5.2  $\log_{10}$  IU/ml, viral breakthrough was observed in only one patient (although no resistant HCV variants were identified), and HCV RNA was undetectable at the end of dosing in up to 63% of treatment-naïve patients. However, the fundamental question of whether an SVR can be achieved with combination therapies of different DAA compounds without PEG-IFN  $\alpha$  and ribavirin was not answered by this trial.

SVR data are available for a Phase II clinical trial investigating therapy with the NS5A inhibitor BMS-790052 in combination with the NS3-4A protease inhibitor BMS-60032 for 24 weeks in 10 HCV genotype 1 patients with a previous null response to PEG-IFN  $\alpha$  and ribavirin (Lok 2011). 36% of patients achieved an SVR 24 weeks after treatment completion. All patients with viral breakthrough were infected with HCV genotype 1a, and in all of them HCV variants with resistance mutations against both agents were detected. Although data of longer follow-up periods are needed, this trial constitutes a proof-of-principle that SVR can be achieved via all-oral regimens, even in patients infected with HCV subtype 1b. This was confirmed with a 100% SVR rate in a small study evaluating the same agents (BMS-790052 and BMS-60032) in Japanese HCV genotype 1b previous null responders (Chayama 2011).

Another trial has investigated 12 weeks of PSI-7977 monotherapy (400 mg once daily) in HCV genotype 2- and 3-infected patients (n=10). 100% of patients achieved an RVR and EOTR, which translated into an SVR in 60% of patients (Gane 2011).

### All-oral therapy with ribavirin

Two trials evaluated all-oral DAA combination therapies with ribavirin. In one of them, combination therapy of the NS3-4A inhibitor BI-201335, the non-nucleoside NS5B inhibitor BI-207127 (400 or 600 mg TID) and ribavirin for 4 weeks was assessed (Zeuzem 2011). Virologic response rates in patients treated with 600 mg TID of BI-207127 were 82%, 100% and 100% at treatment days 15, 22, and 29, respectively (Zeuzem 2011). In patients who received the lower dose of BI-207127, virologic response rates were significantly lower, and in these patients lower

virologic response rates were observed for patients infected with HCV subtype 1a compared to subtype 1b.

Another trial compared tegobuvir (a non-nucleoside NS5B inhibitor) + GS-9256 (a NS3-4A inhibitor) with or without ribavirin in treatment-naïve HCV genotype 1 patients (Zeuzem 2011). Importantly, tegobuvir + GS-9256 + ribavirin led to a higher HCV RNA decline after 28 days of treatment compared to tegobuvir + GS-9256 alone ( $-5.1 \log_{10}$  vs.  $-4.1 \log_{10}$ , respectively), indicating that ribavirin might be an important component of interferon-free DAA combination therapies. SVR data of these and additional combination therapy regimens are expected in the near future.

Additional trials investigated all-oral combination regimens with ribavirin in HCV genotype 2 and 3 patients. 12 weeks of PSI-7977 plus ribavirin resulted in 100% RVR, EOTR, and SVR rates in a small number of treatment-naïve patients ( $n=10$ ) (Gane 2011). In contrast, during treatment with the cyclophilin A inhibitor alisporivir in combination with ribavirin, only approximately 50% of HCV genotype 2 and 3 patients became HCV RNA-negative at treatment week 6 (Pawlotsky 2011). Nevertheless, these data highlight the impressive potential of all-oral regimens, when agents with little risk of antiviral resistance development such as nucleoside analog NS5B inhibitors are used in combination with ribavirin.

**Table 3. Selected trials evaluating DAA combination therapies.**

DAA(s) combined	Additional medication	Phase
BMS-650032 (NS3-4A inhibitor) + BMS-790052 (NS5A inhibitor)	+ / - PEG-IFN $\alpha$ and ribavirin	II
BI-201335 (NS3-4A inhibitor) + BI-207127 (non-nuc. NS5B inhibitor)	+ ribavirin + / - PEG-IFN $\alpha$	II
GS-9190 (non-nuc. NS5B inhibitor) + GS-92568 (NS3-4A inhibitor)	+ / - ribavirin + / - PEG-IFN $\alpha$	II
Danoprevir (NS3-4A inhibitor) + RG-7128 (nuc. NS5B inhibitor)	followed by PEG-IFN $\alpha$ and ribavirin	II
Telaprevir (NS3-4A inhibitor) + VX-222 (non-nuc. NS5B inhibitor)	+ / - ribavirin + / - PEG-IFN $\alpha$	II
PSI-938 (purine nuc. NS5B inhibitor) + PSI-7977 (pyrimidine nuc. NS5B inhibitor)	-	II

## Novel interferons

Over the last years, attempts have been made to reduce side effects and treatment discomfort of PEG-IFN  $\alpha$ . However, interferons with longer half-life and sustained plasma concentrations (e.g., albinterferon, a fusion protein of IFN  $\alpha$  2b with human albumin) have so far shown no overall benefit with respect to SVR rates (Zeuzem 2010). Still promising is the development of pegylated interferon lambda 1 (PEG-IFN lambda 1). Like other type 3 interferons, IFN lambda 1, which is also called interleukin-29 (IL-29), binds to a different receptor than IFN  $\alpha$ , but downstream signaling pathways of IFN lambda and IFN  $\alpha$  are largely comparable. The IFN lambda receptor is predominantly expressed in hepatocytes. Thus, interferon-related side effects may be less frequent during PEG-IFN lambda treatment. A Phase I clinical trial evaluating pegylated interferon lambda with or without ribavirin was completed (Muir 2010). Interferon lambda was well-tolerated and the majority of



patients achieved a greater than 2 log<sub>10</sub> decline of HCV RNA by 4 weeks. According to an interim analysis of a subsequent Phase II clinical trial, PEG-IFN lambda (240 ug, 180 ug, or 120 ug once weekly) was compared to PEG-IFN  $\alpha$ -2a. PEG-IFN lambda at doses of 240 or 180 ug resulted in approximately 10% higher RVR and approximately 20% higher cEVR rates, a lower frequency of flu-like symptoms, but with more frequent aminotransferase and bilirubin elevations than PEG-IFN  $\alpha$ -2a ([Zeuzem 2011](#)).

## Conclusions

Telaprevir- and boceprevir-based triple therapy of treatment-naïve and treatment-experienced HCV genotype 1 patients results in substantially increased SVR rates compared to PEG-IFN- $\alpha$  and ribavirin alone. The approval of these agents represents a major breakthrough in the treatment of chronic hepatitis C. However, successful use of these drugs will require a precise classification of response patterns to previous treatment, careful on-treatment monitoring of HCV viral load and emergence of antiviral resistance as well as of additional side effects and numerous possible drug-drug interactions. Next-generation NS3-4A protease inhibitors and NS5A inhibitors may have even more favorable properties than telaprevir and boceprevir in terms of HCV genotype coverage, safety profiles, less pronounced drug-drug interactions, or possible once-daily administration. However, the triple therapy approach has several limitations. First of all, concomitant IFN  $\alpha$  and ribavirin are necessary to avoid the development of antiviral resistance. Consequently, the efficacy of triple therapy was limited in prior null responders to PEG-IFN  $\alpha$  and ribavirin, and triple therapy cannot be administered to patients with contraindications to PEG-IFN  $\alpha$  or ribavirin. Recent data indicate that the development of DAA combination therapies in all-oral or quadruple treatment regimens will likely be a very potent option for these patients. In such DAA combination regimens, the inclusion of drugs with a high genetic barrier to resistance such as nucleoside NS5B inhibitors or drugs targeting host factors such as alisporivir may be important.

## References

- Afdhal N, O'Brien C, Godofsky E. Valopicitabine alone or with PEG-interferon/ribavirin retreatment in patients with HCV-1 infection and prior non-response to PEGIFN/RBV: One-year results. *J Hepatol* 2007;46:5.
- Ahmed-Belkacem A, Ahnou N, Barbotte L, et al. Silibinin and related compounds are direct inhibitors of hepatitis C virus RNA-dependent RNA polymerase. *Gastroenterology* 2010;138:1112-22. ([Abstract](#))
- Ali S, Leveque V, Le Pogam S, et al. Selected replicon variants with low-level in vitro resistance to the hepatitis C virus NS5B polymerase inhibitor PSI-6130 lack cross-resistance with R1479. *Antimicrob Agents Chemother* 2008;52:4356-69. ([Abstract](#))
- Bacon BR, Gordon SC, Lawitz E, et al. Boceprevir for previously treated chronic HCV genotype 1 infection. *N Engl J Med* 2011;364:1207-17. ([Abstract](#))
- Barnard RJ, Zeuzem S, Vierling J, Sulkowski M, Manns M, Long J. Analysis of resistance-associated amino acid variants in non-SVR patients enrolled in a retrospective long-term follow-up analysis of boceprevir phase 3 clinical trials. *Hepatology* 2011;54:164.
- Bartenschlager R, Frese M, Pietschmann T. Novel insights into hepatitis C virus replication and persistence. *Adv Virus Res* 2004;63:71-180. ([Abstract](#))

- Beaulieu PL. Non-nucleoside inhibitors of the HCV NS5B polymerase: progress in the discovery and development of novel agents for the treatment of HCV infections. *Curr Opin Investig Drugs* 2007;8:614-34. (Abstract)
- Brainard DM, Petry A, Van Dyck K, et al. Safety and antiviral activity of MK-5172, a novel HCV NS3/4A protease inhibitor with potent activity against known resistance mutants, in genotype 1 and 3 HCV-infected patients. *Hepatology* 2010;52:706.
- Chayama K, Takahashi S, Toyota J, et al. Dual therapy with the NS5A inhibitor BMS-790052 and the NS3 protease inhibitor BMS-650032 in HCV genotype 1b-infected null responders. *Hepatology* 2011, in press. (Abstract)
- Cooper C, Lawitz E, Ghali P, et al. Antiviral activity of the non-nucleoside polymerase inhibitor, VCH-759, in chronic hepatitis C patients: Results from a randomized, double-blind, placebo-controlled, ascending multiple dose study. *Hepatology* 2007;46:864.
- Davis GL, Nelson DR, Terrault N, et al. A randomized, open-label study to evaluate the safety and pharmacokinetics of human hepatitis C immune globulin (Civacir) in liver transplant recipients. *Liver Transpl* 2005;11:941-9. (Abstract)
- Erhardt A, Deterding K, Benhamou Y, et al. Safety, pharmacokinetics and antiviral effect of BILB 1941, a novel hepatitis C virus RNA polymerase inhibitor, after 5 days oral treatment. *Antivir Ther* 2009;14:23-32. (Abstract)
- Ferenci P, Scherzer TM, Kerschner H, et al. Silibinin is a potent antiviral agent in patients with chronic hepatitis C not responding to pegylated interferon/ribavirin therapy. *Gastroenterology* 2008;135:1561-7. (Abstract)
- Flisiak R, Feinman SV, Jablkowski M, et al. The cyclophilin inhibitor Debio 025 combined with PEG IFN alpha 2a significantly reduces viral load in treatment-naive hepatitis C patients. *Hepatology* 2009;49:1460-8. (Abstract)
- Flisiak R, Horban A, Gally P, et al. The cyclophilin inhibitor Debio-025 shows potent anti-hepatitis C effect in patients coinfecting with hepatitis C and human immunodeficiency virus. *Hepatology* 2008;47:817-26. (Abstract)
- Flisiak R, Pawlowsky JM, Crabbe R, Callistru PI, Kryczka W, Häussinger D. Once daily alisporivir (Debio025) plus pegIFNalpha2a/ribavirin results in superior sustained virologic response (SVR) in chronic hepatitis C genotype 1 treatment naive patients. *J Hepatol* 2011;54:24.
- Fridell RA, Wang C, Sun JH, et al. Genotypic and phenotypic analysis of variants resistant to hepatitis C virus nonstructural protein 5A replication complex inhibitor BMS-790052 in Humans: In Vitro and In Vivo Correlations. *Hepatology* 2011, in press. (Abstract)
- Gane EJ, Roberts SK, Stedman CA, et al. Oral combination therapy with a nucleoside polymerase inhibitor (RG7128) and danoprevir for chronic hepatitis C genotype 1 infection (INFORM-1): a randomised, double-blind, placebo-controlled, dose-escalation trial. *Lancet* 2010;376:1467-75. (Abstract)
- Gane EJ, Stedman CA, Hyland RH, et al. Once daily PSI-7977 plus RBV: pegylated interferon-alpha not required for complete rapid viral response in treatment-naive patients with HCV Gt2 or Gt3. *Hepatology* 2011;54:18.
- Gao M, Nettles RE, Belema M, et al. Chemical genetics strategy identifies an HCV NS5A inhibitor with a potent clinical effect. *Nature* 2010;465:96-100. (Abstract)
- Gaudieri S, Rauch A, Pfafferott K, et al. Hepatitis C virus drug resistance and immune-driven adaptations: relevance to new antiviral therapy. *Hepatology* 2009;49:1069-82. (Abstract)
- Hezode C, Hirschfield GM, Ghesquiere W, et al. BMS-790052, a NS5A replication complex inhibitor, combined with peginterferon alfa-2a and ribavirin in treatment-naive HCV-genotype 1 or 4 patients: phase 2b A1444010 study interim week 12 results. *Hepatology* 2011;54:115.
- Hinrichsen H, Benhamou Y, Wedemeyer H, et al. Short-term antiviral efficacy of BILN 2061, a hepatitis C virus serine protease inhibitor, in hepatitis C genotype 1 patients. *Gastroenterology* 2004;127:1347-55. (Abstract)
- Jacobson IM, McHutchison JG, Dusheiko G, et al. Telaprevir for previously untreated chronic hepatitis C virus infection. *N Engl J Med* 2011;364:2405-16. (Abstract)
- Jacobson IM, Pockros PJ, Lalezari JP, et al. Virologic response rates following 4 weeks of filibuvir in combination with pegylated interferon-alpha-2a and ribavirin in chronically infected HCV genotype 1 patients. *J Hepatol* 2010;52:465.
- Janssen HL, Reesink HW, Zeuzem S, et al. A randomized, double-blind, placebo controlled safety and anti-viral proof of concept study of miraviren, an oligonucleotide targeting

- mir-122, in treatment naive patients with genotype 1 chronic HCV infection. *Hepatology* 2010;54:1071.
- Kim JL, Morgenstern KA, Griffith JP, et al. Hepatitis C virus NS3 RNA helicase domain with a bound oligonucleotide: the crystal structure provides insights into the mode of unwinding. *Structure* 1998;6:89-100. (Abstract)
- Kim JL, Morgenstern KA, Lin C, et al. Crystal structure of the hepatitis C virus NS3 protease domain complexed with a synthetic NS4A cofactor peptide. *Cell* 1996;87:343-55. (Abstract)
- Kneteman NM, Howe AY, Gao T, et al. HCV796: A selective nonstructural protein 5B polymerase inhibitor with potent anti-hepatitis C virus activity in vitro, in mice with chimeric human livers, and in humans infected with hepatitis C virus. *Hepatology* 2009;49:745-52. (Abstract)
- Koch U, Narjes F. Allosteric inhibition of the hepatitis C virus NS5B RNA dependent RNA polymerase. *Infect Disord Drug Targets* 2006;6:31-41. (Abstract)
- Lamarre D, Anderson PC, Bailey M, et al. An NS3 protease inhibitor with antiviral effects in humans infected with hepatitis C virus. *Nature* 2003;426:186-9. (Abstract)
- Landford RE, Hildebrandt-Eriksen ES, Petri A, et al. Therapeutic silencing of microRNA-122 in primates with chronic hepatitis C virus infection. *Science* 2010;327:198-201. (Abstract)
- Lawitz E, Lalezari JP, Hassanein T, et al. Once-daily PSI-7977 plus peg/RBV in treatment-naive patients with HCV GT1: robust end of treatment response rates are sustained post-treatment. *Hepatology* 2011;54:113.
- Lenz O, Fevery B, Vigen L, et al. TMC435 in combination with peginterferon alpha-2a/ribavirin in treatment-naive patients infected with HCV genotype 1: virology analysis of the Pillar study. *Hepatology* 2011;54:985.
- Lesburg CA, Cable MB, Ferrari E, Hong Z, Mannarino AF, Weber PC. Crystal structure of the RNA-dependent RNA polymerase from hepatitis C virus reveals a fully encircled active site. *Nat Struct Biol* 1999;6:937-43. (Abstract)
- Lin C, Gates CA, Rao BG, et al. In vitro studies of cross-resistance mutations against two hepatitis C virus serine protease inhibitors, VX-950 and BILN 2061. *J Biol Chem* 2005;280:36784-91. (Abstract)
- Lindenbach BD, Evans MJ, Syder AJ, et al. Complete replication of hepatitis C virus in cell culture. *Science* 2005;309:623-6. (Abstract)
- Lohmann V, Korner F, Koch J, Herian U, Theilmann L, Bartenschlager R. Replication of subgenomic hepatitis C virus RNAs in a hepatoma cell line. *Science* 1999;285:110-3.
- Lok AS, Gardiner DF, Lawitz E. Quadruple therapy with BMS-790052, BMS-650032 and Peg-IFN/RBV for 24 weeks results in 100% SVR12 in HCV genotype null responders. *J Hepatol* 2011;54:536.
- Lorenz IC, Marcotrigiano J, Dentzer TG, Rice CM. Structure of the catalytic domain of the hepatitis C virus NS2-3 protease. *Nature* 2006;442:831-5. (Abstract)
- Manns M, Reesink H, Berg T, et al. Rapid viral response of once-daily TMC435 plus pegylated interferon/ribavirin in hepatitis C genotype-1 patients: a randomized trial. *Antivir Ther* 2011;16:1021-33. (Abstract)
- McCown MF, Rajyaguru S, Kular S, Cammack N, Najera I. GT-1a or GT-1b subtype-specific resistance profiles for hepatitis C virus inhibitors telaprevir and HCV-796. *Antimicrob Agents Chemother* 2009;53:2129-32. (Abstract)
- Meylan E, Curran J, Hofmann K, et al. Cardif is an adaptor protein in the RIG-I antiviral pathway and is targeted by hepatitis C virus. *Nature* 2005;437:1167-72. (Abstract)
- Moradpour D, Penin F, Rice CM. Replication of hepatitis C virus. *Nat Rev Microbiol* 2007;5:453-63. (Abstract)
- Muir AJ, Shiffman ML, Zaman A, et al. Phase 1b study of pegylated interferon lambda 1 with or without ribavirin in patients with chronic genotype 1 hepatitis C virus infection. *Hepatology* 2010;52:822-32. (Abstract)
- Nelson DR, Gane EJ, Jacobson IM, Di Bisceglie AM, Alves K, Koziel MJ. VX-222/Telaprevir in combination with peginterferon-alfa-2a and ribavirin in treatment-naive genotype 1 HCV patients treated for 12 weeks: Zenith study, SVR 12 interim analyses. *Hepatology* 2011;54:1442.
- Nettles RE, Gao M, Bifano M, et al. Multiple ascending dose study of BMS-790052, an NS5A replication complex inhibitor, in patients infected with hepatitis C virus genotype 1. *Hepatology* 2011, in press.

- Pawlotsky JM, Flisiak R, Rasenack J, et al. Once daily alisporivir interferon-free regimens achieve high rates of early HCV clearance in previously untreated patients with HCV genotype 2 or 3. *Hepatology* 2011;54:1074.
- Pockros P, Jensen DM, Tsai N. First SVR data with the nucleoside analogue polymerase inhibitor mericitabine (RG7128) combined with peginterferon/ribavirin in treatment-naive HCV G1/4 patients: interim analysis of the JUMP-C trial. *J Hepatol* 2011;54:538.
- Pockros P, Nelson D, Godofsky E, et al. High relapse rate seen at week 72 for patients treated with R1626 combination therapy. *Hepatology* 2008;48:1349-50. (Abstract)
- Pockros PJ, Nelson D, Godofsky E, et al. R1626 plus peginterferon Alfa-2a provides potent suppression of hepatitis C virus RNA and significant antiviral synergy in combination with ribavirin. *Hepatology* 2008;48:385-97. (Abstract)
- Poordad F, McCone J Jr, Bacon BR, et al. Boceprevir for untreated chronic HCV genotype 1 infection. *N Engl J Med* 2011;364:1195-206. (Abstract)
- Reesink HW, Fanning GC, Farha KA, et al. Rapid HCV-RNA decline with once daily TMC435: a phase I study in healthy volunteers and hepatitis C patients. *Gastroenterology* 2010;138:913-21. (Abstract)
- Reesink HW, Zeuzem S, Weegink CJ, et al. Rapid decline of viral RNA in hepatitis C patients treated with VX-950: a phase Ib, placebo-controlled, randomized study. *Gastroenterology* 2006;131:997-1002. (Abstract)
- Reiser M, Hinrichsen H, Benhamou Y, et al. Antiviral efficacy of NS3-serine protease inhibitor BILN-2061 in patients with chronic genotype 2 and 3 hepatitis C. *Hepatology* 2005;41:832-5. (Abstract)
- Rosignol JF, Elfert A, El-Gohary Y, Keeffe EB. Improved virologic response in chronic hepatitis C genotype 4 treated with nitazoxanide, peginterferon, and ribavirin. *Gastroenterology* 2009;136:856-62. (Abstract)
- Sarrazin C, Kieffer TL, Bartels D, et al. Dynamic hepatitis C virus genotypic and phenotypic changes in patients treated with the protease inhibitor telaprevir. *Gastroenterology* 2007;132:1767-77. (Abstract)
- Sarrazin C, Rouzier R, Wagner F, et al. SCH 503034, a novel hepatitis C virus protease inhibitor, plus pegylated interferon alpha-2b for genotype 1 nonresponders. *Gastroenterology* 2007;132:1270-8. (Abstract)
- Sarrazin C, Zeuzem S. Resistance to direct antiviral agents in patients with hepatitis C virus infection. *Gastroenterology* 2010;138:447-62. (Abstract)
- Schiano TD, Charlton M, Younossi Z, et al. Monoclonal antibody HCV-AbXTL68 in patients undergoing liver transplantation for HCV: results of a phase 2 randomized study. *Liver Transpl* 2006;12:1381-9. (Abstract)
- Sherman KE, Flamm SL, Afdhal NH, et al. Response-guided telaprevir combination treatment for hepatitis C virus infection. *N Engl J Med* 2011;365:1014-24. (Abstract)
- Sherman KE, Sulkowski M, Zoulim F, Alberti A. Follow-up of SVR durability and viral resistance in patients with chronic hepatitis C treated with telaprevir-based regimens: interim analysis of the extend study. *Hepatology* 2011;54:1471.
- Shi ST, Polyak SJ, Tu H, Taylor DR, Gretch DR, Lai MM. Hepatitis C virus NS5A colocalizes with the core protein on lipid droplets and interacts with apolipoproteins. *Virology* 2002;292:198-210. (Abstract)
- Susser S, Vermehren J, Forestier N, et al. Analysis of long-term persistence of resistance mutations within the hepatitis C virus NS3 protease after treatment with telaprevir or boceprevir. *J Clin Virol* 2011. (Abstract)
- Tellinghuisen TL, Marcotrigiano J, Rice CM. Structure of the zinc-binding domain of an essential component of the hepatitis C virus replicase. *Nature* 2005;435:374-9. (Abstract)
- Wagoner J, Negash A, Kane OJ, et al. Multiple effects of silymarin on the hepatitis C virus lifecycle. *Hepatology* 2010;51:1912-21. (Abstract)
- Wakita T, Pietschmann T, Kato T, et al. Production of infectious hepatitis C virus in tissue culture from a cloned viral genome. *Nat Med* 2005;11:791-6. (Abstract)
- Welsch C, Domingues FS, Susser S, et al. Molecular basis of telaprevir resistance due to V36 and T54 mutations in the NS3-4A protease of the hepatitis C virus. *Genome Biol* 2008;9:R16. (Abstract)
- Wohnsland A, Hofmann WP, Sarrazin C. Viral determinants of resistance to treatment in patients with hepatitis C. *Clin Microbiol Rev* 2007;20:23-38. (Abstract)

- Zeuzem S, Andreone P, Pol S, et al. Telaprevir for retreatment of HCV infection. *N Engl J Med* 2011;364:2417-28. ([Abstract](#))
- Zeuzem S, Arora S, Bacon B, Box T, Charlton M. Pegylated interferon-lambda shows superior viral response with improved safety and tolerability versus pegIFN-alfa-2a in hCV patients (G1/2/3/4): merge phase IIB through week 12. *J Hepatol* 2011;54:538.
- Zeuzem S, Asselah T, Angus P, et al. Efficacy of the Protease Inhibitor BI 201335, Polymerase Inhibitor BI 207127, and Ribavirin in Patients With Chronic HCV Infection. *Gastroenterology* 2011, in press. ([Abstract](#))
- Zeuzem S, Berg T, Moeller B, et al. Expert opinion on the treatment of patients with chronic hepatitis C. *J Viral Hepat* 2009;16:75-90. ([Abstract](#))
- Zeuzem S, Buggisch P, Agarwal K, et al. The protease inhibitor GS-9256 and non-nucleoside polymerase inhibitor tegobuvir alone, with RBV or peginterferon plus RBV in hepatitis C. *Hepatology* 2011, in press. ([Abstract](#))
- Zeuzem S, Sulkowski MS, Lawitz EJ, et al. Albinterferon Alfa-2b was not inferior to pegylated interferon-alpha in a randomized trial of patients with chronic hepatitis C virus genotype 1. *Gastroenterology* 2010;139:1257-66. ([Abstract](#))

# 15. Management of Adverse Drug Reactions

*Martin Schaefer and Stefan Mauss*

## Introduction

Good adherence is a key factor for success in the treatment of hepatitis C. However, almost all patients on treatment with interferon and ribavirin will experience adverse events that can threaten good adherence. Therefore, proactive clinical management is crucial to avoid suboptimal therapy and treatment discontinuations.

The most common adverse events in patients on treatment with pegylated interferon plus ribavirin are flu-like symptoms, myalgia, sleep disturbances, asthenia, gastrointestinal disorders and depressive episodes (Table 1).

**Table 1. Incidence of most reported IFN  $\alpha$ -induced psychiatric side effects.** Data from Outpatient Department, Essen-Mitte Clinics, Essen.

Psychiatric side effects	Incidence
Fatigue	50-80%
Sleep disturbances	45-65%
Irritability	60-85%
Cognitive disturbances with impairments of concentration and memory	45-60%
Depressive episodes	20-60%
Mild	30-60%
Moderate	20-30%
Severe	5-10%
Delirium, psychosis	1-6%
Suicidal syndrome	<1%

For most adverse events, clinical trials with dose adjustment have not been done, and because of this, recommendations in this review are necessarily partially based on clinical experience.

## Flu-like symptoms, fever, arthralgia and myalgia

Flu-like symptoms, fever, arthralgia and myalgia appear a few hours after the PEG-IFN injection and may last for up to three days. One common approach is the use of

paracetamol or other NSAIDs immediately before or after the injection of interferon. Flu-like symptoms usually diminish spontaneously over the first weeks of treatment (Figure 1).

Low platelets are a contraindication for the use of acetylsalicylic acid, diclofenac or ibuprofen because of the inhibition of platelet aggregation. High doses of paracetamol may result in liver toxicity. Doses exceeding 2 g/day of paracetamol are not recommended.

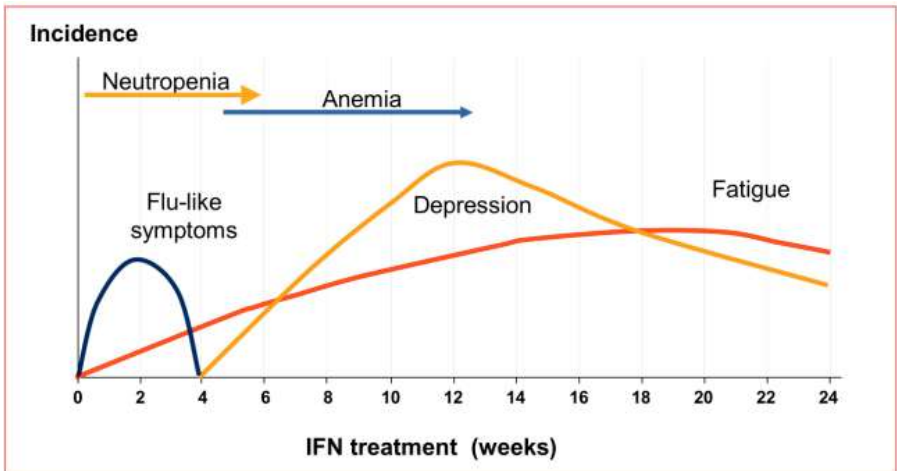


Figure 1. Time course of interferon-associated adverse events.

## Gastrointestinal disorders

Nausea can be mitigated by prokinetic agents such as metoclopramide or domperidone taken before the ribavirin. This may also positively influence the frequently observed loss of appetite.

Dry mouth has been reported as a result of inhibition of saliva production, a frequent complication of ribavirin, which may continue after discontinuation of therapy.

## Weight loss

The average weight loss in interferon-based controlled studies is around 6-10% for a treatment period of 48 weeks (Seyam 2004). This may be predominantly due to loss of appetite and reduction in calorie intake. The weight loss is rapidly reversible upon discontinuation of therapy.

## Asthenia and fatigue

Asthenia and fatigue are frequent complaints of patients that usually increase slowly in intensity over the first couple weeks of therapy (Figure 1). In patients with marked anemia these symptoms can be improved by raising low hemoglobin with

the use of erythropoietin, reduction of ribavirin or red blood cell transfusion (Pockros 2004). Asthenia is also reported by patients without marked anemia. In these patients hypothyroidism may be the explanation. Symptomatic treatment of asthenia and fatigue in patients without an underlying complication such as anemia, depression or hypothyroidism is difficult.

Chronic fatigue has been successfully treated in individual cases with antidepressants or tryptophan (Sammot 2002; Schaefer 2008). A first prospective randomised controlled trial showed superior effects of the 5-HT<sub>3</sub> receptor antagonist ondansetron compared to placebo (Piche 2005). However, currently available data does not offer specific treatment recommendations.

## Cough and dyspnea

Cough while on therapy is frequently reported and is most probably due to edema of the mucosa of the respiratory system. Therefore, advanced, not well-controlled asthma bronchiale may be a contraindication for hepatitis C therapy. Dyspnea is another frequent complaint with a more complex etiology involving mucosa swelling, anemia and asthenia.

## Disorders of the thyroid gland

Hypothyroidism while on interferon-based therapy is reported with an incidence of 3-10% (Bini 2004, Tran 2005). Hyperthyroidism is less frequently observed with an incidence of 1-3% (Bini 2004, Tran 2005). Interferon-induced thyroiditis or the induction of thyroid antibodies is reported as an underlying mechanism. Hypothyroidism is treated via substitution of thyroid hormone whereas clinical symptomatic hyperthyroidism may be treated with  $\beta$ -blockers or carbimazole. Premature termination of interferon-based therapy is usually not necessary. About half of the cases of hypothyroidism are reversible upon discontinuation of interferon-based therapy, although some cases may need prolonged periods of thyroid hormone replacement therapy.

## Psychiatric adverse events

### Incidence and profile of psychiatric adverse events

The most commonly emerging IFN  $\alpha$ -induced psychiatric adverse events are outlined in Table 1. However, data on the frequency of psychiatric side effects differs depending on the design of the trial. Most hepatological trials are only monitored for depression as a single symptom without using depression scales or diagnostic instruments, leading to an underreporting of mild to moderate depressive episodes. Most psychiatric trials used self-rating scales (e.g., SDS-scale, BDI-Scale) or monitor patients via expert rating scales (Hamilton Depression Scale [HAMDS] or Montgomery Asperg Depression Scale [MADRS]) to detect depressive syndromes and treatment-related mood changes even if total scores do not fulfil DSM-IV criteria for major depression. Regarding these more sensitive psychiatric rating methods, over 50% of patients suffer from sleep disorders, chronic fatigue, irritability or cognitive disturbances (Schaefer 2007, Schaefer 2002, Dieperink 2000, Renault 1987). Anxiety occurs in 30-45%, especially during the first 2 months



of treatment. Mild depression with symptoms like reduced self-esteem, anhedonia, loss of interest, rumination, a diminished libido and spontaneous crying can be observed in 30-60% of the patients. 20-30% of treated patients develop moderate to severe depressive episodes (Bonnaccorso 2002, Dieperink 2000, Renault 1987, Schaefer 2002, Malaguarnera 2002). Major depression has been reported in 15-55% (Schäfer 2007). Suicidal ideation is seen in 5-6% of patients, while suicide attempts have been reported in single cases (Janssen 1994, Sockalingam 2010). Mania has been reported as a sporadically appearing side effect. Contrary to assumptions, patients with pre-existing psychiatric disturbances do not appear to have a greater risk for development of depression or attempting suicide (Schaefer 2007, Schaefer 2003, Pariante 2002). However, patients with intravenous drug abuse not stabilized in a substitution treatment program (e.g., methadone) seem more likely to discontinue treatment in the first three months compared to controls (Schaefer 2003, Mauss 2004, Schaefer 2007).

Antidepressants frequently used in trials are selective serotonin re-uptake inhibitors (SSRIs) such as citalopram, escitalopram, paroxetine or sertraline. The introduction of SSRIs and other current antidepressants has markedly improved the adverse event profile of antidepressants. Therefore, depending on the major symptoms, current sedating or activating antidepressants, especially SSRIs, are treatment of choice for interferon-induced depressive mood disorders (Table 2). In patients with predominantly agitation and aggression, other strategies, e.g., modern antipsychotics, may be added.

The efficacy of antidepressants for the treatment of interferon  $\alpha$ -induced depression has been shown in several open uncontrolled cohorts (Farah 2002, Gleason 2002, Kraus 2001, Schramm 2000, Hauser 2002, Gleason 2005). In a first prospective randomized controlled trial an improvement of depressive symptoms after treatment of IFN-associated depression was shown with citalopram compared to placebo (Kraus 2008). In particular because of the favourable adverse event profile, SSRIs seem to be most appropriate for treatment of IFN  $\alpha$ -associated depressive symptoms. However, antidepressants with different receptor profiles (i.e., mirtazapine) and classic antidepressants (i.e., nortriptyline) are also effective (Kraus 2001, Valentine 1995). Nevertheless, tricyclic antidepressants should be used as second choice because of pharmacological interactions, anticholinergic side effects, a higher risk for development of delirium, and liver or myocardial toxicity. To reduce early occurring adverse events of SSRIs (headache, nausea, agitation), treatment with antidepressants should be started at a low dose with subsequent dose increase depending on the effect and tolerability. In general, a therapeutically relevant antidepressive effect cannot be expected before day 8-14 of treatment. In case of non-response, the dose can be escalated. Treatment adherence should be assessed by monitoring serum levels before patients are switched to a different antidepressant.

Benzodiazepines can be given for a short period in case of severe sleep disturbances, irritability or depression. However, benzodiazepines should be avoided in patients with a history of IV drug or alcohol over-use because of their potential to induce addiction.

In the case of psychotic symptoms, antipsychotics (e.g., risperidone, olanzapine) can be used at low doses, but patients should be monitored carefully by a

psychiatrist. One important risk factor for the development of psychotic symptoms is a history of drug use.

Although history of major depression or suicide attempts is considered a contraindication for interferon-based therapy, treatment of patients with pre-existing psychiatric disorders can be initiated in close collaboration with an experienced psychiatrist in a well-controlled setting (Schaefer 2004, Schaefer 2007).

It must be mentioned that so far there is no systematic experience with combination of the recently approved HCV protease inhibitors and antidepressants. While the new antiviral drugs telaprevir or boceprevir do not induce specific psychiatric side effects, drug-drug interactions may complicate the use of antidepressants and sleep medications.

### **Preemptive therapy with antidepressants**

One double-blind randomised study with patients with malignant melanoma demonstrated that 14 days of pre-treatment with 20 mg paroxetine per day reduced the incidence of depression during interferon therapy significantly (Musselmann 2001). Pre-treatment with paroxetine also had a positive effect on the development of fears, cognitive impairments and pain during interferon treatment, but not on symptoms such as fatigue, sleep disturbances, anhedonia and irritability (Capuron 2002). A recent prospective controlled trial with HCV-infected patients demonstrated that pre-treatment with citalopram significantly reduced depression during the first 6 months of antiviral therapy in patients with psychiatric illness compared to controls (Schaefer 2005). Furthermore, prophylactic treatment with SSRIs was shown to reduce the severity of depressive symptoms in patients who had suffered from severe depression during previous treatment of hepatitis C with interferon  $\alpha$  (Kraus 2005). A recent trial confirmed a protective effect of preemptive initiation of treatment with antidepressants before starting interferon-based therapy in cases of elevated depression scores (Raison 2007). However, three other trials could not show significant effects on reduction of depressive symptoms nor overall incidence of major depression, although these trials were either small in size or had short observation times (Morasco 2007, Morasco 2010, Diez-Quevedo 2010). In summary, current data support the view that all patients with pre-existing depressive symptoms should receive a prophylactic treatment with antidepressants. However, larger prospective controlled studies are needed in order to answer the question if antidepressants should be given before antiviral plus interferon-based therapy, independent of pre-existing psychiatric disorders.

### **Sleep disturbances**

Patients who have difficulties in falling asleep can be treated with zopiclone or trimipramine. Zolpidem may be used for patients with interrupted or shortened sleep patterns. Although the risk of addiction is markedly reduced compared with other benzodiazepines, only small amounts of zopiclone or zolpidem should be prescribed at a time and therapy should be limited to the period of interferon-based therapy. As sleeping disorders can be an early symptom of depression, it is also important to assess the possible presence of other depressive symptoms when considering the use of sleeping aids.

## Hematological and immunologic effects

Interferon-based therapy is accompanied by a marked drop in white blood cells in general, neutrophils and absolute, although not relative, CD4+ cell count. This change of the cellular immune system does not result in an increased number of serious infections even in HIV-coinfected patients (Fried 2002, Manns 2001, Torriani 2004). In general, the incidence of serious infections is low (<5%) in patients on interferon-based therapy.

G-CSF increases neutrophils in patients treated with interferon-based therapies. However G-CSF has not been proven to have a clinical benefit in clinical trials for this purpose and its use is off-label. Hemolytic anemia induced by ribavirin is further aggravated by the myelosuppressive effect of interferon inhibiting compensatory reticulocytosis (De Franceschi 2000). As a consequence, anemia (<10 g/dl) is reported in up to 20% of patients (Hadziyannis 2004). In severe cases of anemia dose reduction of ribavirin is required. In rare cases red blood cell transfusion may be necessary. Erythropoietin can be successfully used to correct the ribavirin-induced anemia at least partially and to avoid ribavirin dose reduction or red blood cell transfusions. In addition erythropoietin use was associated with an improved quality of life. However, prospective controlled trials have not shown a positive effect on the efficacy of hepatitis C therapy in patients who take erythropoietin (Afdahl 2004, Pockros 2004, Shiffman 2007). At present, erythropoietin is not approved for correction of ribavirin-induced anemia in hepatitis C therapy.

Mild to moderate thrombocytopenia is frequently seen in patients with advanced liver fibrosis and may complicate interferon-based therapy. Reduction of interferon dosing may be indicated to reverse severe thrombocytopenia. In studies eltrombopag has been used successfully to increase platelet count in patients with hepatitis C associated thrombocytopenia (McHutchison 2007). In recent trials eltrombopag even increased efficacy of hepatitis C treatment in cirrhotic patients, although the occurrence of portal vein thrombosis was observed in a number of patients cautioning its widespread use (Afdhal 2011).

## Skin disorders and hair loss

Some skin disorders such as lichen ruber planus, necrotising vasculitis or porphyrea cutanea tarda are associated with hepatitis C infection. The effects of hepatitis C therapy are often not well-studied and based only on information gathered through cohorts (Berk 2007).

Interferon and ribavirin therapy may have an effect on the skin itself including dry skin, itching, eczema and new or exacerbated psoriasis. Ointments with rehydrating components, urea or steroids can be used depending on the nature of the skin disorders. In severe cases a dermatologist should be involved. In particular, eczema and psoriasis may last substantially longer than the treatment period with interferon-based therapy.

Local skin reactions to the injection of pegylated interferon are common and usually present as red indurations lasting days to weeks. Repeated injections at the same site may cause ulcers and should be avoided. Hypersensitivity reactions to pegylated interferons are reported anecdotally.

Hair loss is frequent, usually appearing after the first months of therapy and continuing for some weeks after the cessation of therapy. Alopecia is very rare and

hair loss is usually fully reversible, although the structure of the hair may be different after therapy.

### **Adverse events with telaprevir and boceprevir**

Triple combination therapy of pegylated interferon, ribavirin plus one of the newer HCV protease inhibitors telaprevir or boceprevir is standard of care for the treatment of most genotype 1 patients. This treatment provides better efficacy, but also new challenges for adherence and management of adverse events. In general all adverse events caused by interferon and ribavirin remain, however some may be accentuated or new adverse events may occur.

In addition, boceprevir and telaprevir are simultaneous inducers and inhibitors of multiple enzymes of the cytochrome P450 system. For this reason, drug-drug interactions are not easy to predict and involve frequently used drugs such as sedatives, antidepressants, antibiotics, immunosuppressants, oral corticosteroids, statins and calcium channel blockers. As this is an evolving area, for updated information, the website [www.hep-druginteractions.org](http://www.hep-druginteractions.org) should be checked regularly.

Boceprevir and telaprevir have to be taken three times a day with food or a fat-containing meal, respectively. Pill burden is high with 12 pills for boceprevir and 6 for telaprevir. Dosing and taking the medication not fasting are crucial for efficacy. Boceprevir or telaprevir doses should never be reduced in case of toxicities, but rather discontinued or kept at the standard dose. Reducing the dose of these HCV protease inhibitors will result in treatment failure due to lower drug exposure.

Frequent adverse events seen with telaprevir are itching and rash, with the first occurring in the majority of patients. Itching can be orally treated with antihistamines, e.g., cetirizine, but efficacy seems limited. Rash is usually mild to moderate while serious skin reactions seem to be rare. Discontinuation is rarely necessary. Use of corticosteroid-based ointments, e.g., betamethasone 0.1% together with rehydrating and/or urea-containing creams are the treatments of choice for rash. For a serious case of psoriasis a consultation of an experienced dermatologist is advisable. Anal symptoms ranging from discomfort to pain and bleeding are also common. Depending on the severity, local therapy with a zinc paste or corticosteroid ointments are used.

A more frequent and more pronounced anemia than what is seen with interferon plus ribavirin may require dose adjustment of ribavirin or red blood cell transfusion. The use of erythropoietin for mitigation of anemia is not approved, but can be tried where reimbursement is possible.

Nausea and diarrhea are frequently seen in patients on telaprevir and may require symptomatic therapy (Hézode 2009, McHutchison 2009, McHutchison 2010, Marcellin 2010).

With boceprevir, anemia is the most important adverse event requiring dose adjustment of ribavirin or red blood cell transfusion in a considerable number of patients. Dysgeusia is another frequent complaint that resolves upon discontinuation (Bacon 2011, Poordad 2011).

## Adherence

Adherence data from retrospective analyses suggest that at least 80% of the cumulative doses of ribavirin and interferon should be taken by patients as a prerequisite for treatment success. Cumulative doses of less than 80% were associated with a steep drop in sustained virologic response (Camma 2005). Another surrogate of adherence is the premature treatment discontinuation rate, which usually ranges from 10–15% with pegylated interferon and ribavirin (Fried 2002, Manns 2001).

The added mandatory intake of food as a complication of HCV protease inhibitors has heightened the adherence concerns.

Despite these increased complications, discontinuation rates in the triple-therapy arms were only slightly higher in the registration trials, leading to the approval of boceprevir and telaprevir, indicating a better management of drug-related toxicities (Bacon 2011, Marcellin 2010, McHutchinson 2010, Poordad 2011).

## Conclusion

In summary, the toxicity of interferon-based therapy plus ribavirin is considerable and requires active management and profound knowledge, particularly about the management of psychiatric adverse events.

The first generation of HCV protease and polymerase inhibitors will improve the efficacy of therapy, in particular in HCV genotype 1 patients, but at the cost of increased toxicities during therapy. Early assessment and robust management of adverse events may prevent premature treatment discontinuations and improve the efficacy of hepatitis C therapy.

## References

- Afdhal NH, Dieterich DT, Pockros PJ, et al. Epoetin alfa maintains ribavirin dose in HCV-infected patients: a prospective, double-blind, randomized controlled study. *Gastroenterology* 2004;126:1302-11. ([Abstract](#))
- Afdhal NH, Dusheiko G, Giannini EG, et al. Final Results of ENABLE 1, a Phase 3, Multicenter Study of Eltrombopag as an Adjunct for Antiviral Treatment of Hepatitis C Virus-Related Chronic Liver Disease Associated With Thrombocytopenia. *Hepatology* 2011; 54:1427-8.
- Bacon BR, Gordon SC, Lawitz E, et al. Boceprevir for previously treated chronic HCV genotype 1 infection. *N Engl J Med* 2011;364:1207-17. ([Abstract](#))
- Berk DR, Mallory SB, Keeffe EB, Ahmed A. Dermatologic disorders associated with chronic hepatitis C: effect of interferon therapy. *Clin Gastroenterol Hepatol* 2007;5:142-51. ([Abstract](#))
- Bini EJ, Mehandru S. Incidence of thyroid dysfunction during interferon alfa-2b and ribavirin therapy in men with chronic hepatitis C: a prospective cohort study. ([Abstract](#)) *Arch Intern Med* 2004; 164:2371-76.
- Bonaccorso S, Marino V, Puzella, et al. Increased depressive ratings in patients with hepatitis C receiving interferon-alpha-based immunotherapy are related to interferon-alpha-induced changes in the serotonergic system. *J Clin Psychopharmacol* 2002; 22:86-90. ([Abstract](#))
- Cammà C, Licata A, Cabibbo G, Latteri F, Craxi A. Treatment of hepatitis C: critical appraisal of the evidence. *Expert Opin Pharmacother* 2005;6:399-408. ([Abstract](#))
- Capuron L, Ravaut A, Neveu PJ, Miller AH, Maes M, Dantzer R. Association between decreased serum tryptophan concentrations and depressive symptoms in cancer patients undergoing cytokine therapy. *Mol Psychiatry* 2002;7:468-473. ([Abstract](#))

- De Franceschi L, Fattovich G, Turrini F, et al. Hemolytic anemia induced by ribavirin therapy in patients with chronic hepatitis C virus infection: role of membrane oxidative damage. *Hepatology* 2000; 31:997-1004. ([Abstract](#))
- Dieperink E, Willenbring M, Ho SB. Neuropsychiatric symptoms associated with hepatitis C and interferon alpha: A review. *Am J Psychiatry* 2000;157:867-76. ([Abstract](#))
- Diez-Quevedo C, Masnou H, Planas R, Castellvi P, Gimenez D, Morillas RM, et al. Prophylactic treatment with escitalopram of pegylated interferon alfa-2a-induced depression in hepatitis C: a 12-week, randomized, double-blind, placebo-controlled trial. *J Clin Psychiatry* 2011;72:522-8. ([Abstract](#))
- Farah A. Interferon-induced depression treated with citalopram. *J Clin Psychiatry* 2002; 63:166-7. ([Abstract](#))
- Fried M, Shiffman M, Reddy R, et al. Peginterferon alfa-2a plus ribavirin for chronic hepatitis C virus infection. *N Engl J Med* 2002;347:975-82. ([Abstract](#))
- Gleason OC, Yates WR, Isbell MD, Philippsen MA. An open-label trial of citalopram for major depression in patients with hepatitis C. *J Clin Psychiatry* 2002;63:194-8. ([Abstract](#))
- Gleason OC, Yates WR, Philippsen MA. Major depressive disorder in hepatitis C: an open-label trial of escitalopram. *Prim Care Companion J Clin Psychiatry* 2005;7:225-30. ([Abstract](#))
- Hadziyannis SJ, Sette H Jr, Morgan TR, et al. Peginterferon-alpha2a and ribavirin in combination therapy in chronic hepatitis C: a randomized study of treatment duration and ribavirin dose. *Ann Intern Med* 2004;140:346-55. ([Abstract](#))
- Hauser P, Khosla J, Aurora H, et al. A prospective study of the incidence and open-label treatment of interferon-induced major depressive disorder in patients with hepatitis C. *Mol Psychiatry* 2002;7:942-7. ([Abstract](#))
- Janssen HL, Brouwer JT, van der Mast RC, Schalm SW. Suicide associated with alfa-interferon therapy for chronic viral hepatitis. *J Hepatol* 1994;21:241-3. ([Abstract](#))
- Kraus MR, Schafer A, Scheurlen M. Paroxetine for the prevention of depression induced by interferon alfa. *N Engl J Med* 2001;345:375-6. ([Abstract](#))
- Kraus MR, Schafer A, Faller H, Csef H, Scheurlen M. Paroxetine for the treatment of interferon-alpha-induced depression in chronic hepatitis C. *Aliment Pharmacol Ther* 2002;16:1091-9. ([Abstract](#))
- Kraus MR, Schafer A, Al-Taie O, Scheurlen M. Prophylactic SSRI during interferon alpha re-therapy in patients with chronic hepatitis C and a history of interferon-induced depression. *J Viral Hepat* 2005;12:96-100. ([Abstract](#))
- Kraus MR, Schafer A, Schottker K, et al. Therapy of interferon-induced depression in chronic hepatitis C with citalopram: A randomized, double-blind, placebo-controlled study. *Gut*. 2008;57:531-6. ([Abstract](#))
- Malaguarnera M, Laurino A, Di F, et al. Neuropsychiatric effects and type of IFN-alpha in chronic hepatitis C. *J Interferon Cytokine Res* 2001;21:273-8. ([Abstract](#))
- Manns M, McHutchison J, Gordon S, et al. Peginterferon alfa-2b plus ribavirin compared with interferon alfa-2b plus ribavirin for initial treatment of chronic hepatitis C: a randomised trial. *Lancet* 2001;358:958-65. ([Abstract](#))
- McHutchison JG, Dusheiko G, Shiffman ML, et al. Eltrombopag for thrombocytopenia in patients with cirrhosis associated with hepatitis C. *N Engl J Med* 2007;357:2227-36. ([Abstract](#))
- Mauss S, Berger F, Goelz J, Jacob B, Schmutz G. A prospective controlled study of interferon-based therapy of chronic hepatitis C in patients on methadone maintenance. *Hepatology* 2004;40:120-4. ([Abstract](#))
- Morasco BJ, Rifai MA, Loftis JM, Indest DW, Moles JK, Hauser P. A randomized trial of paroxetine to prevent interferon-alpha-induced depression in patients with hepatitis C. *J Affect Disord* 2007;103:83-90. ([Abstract](#))
- Morasco BJ, Loftis JM, Indest DW, et al. Prophylactic antidepressant treatment in patients with hepatitis C on antiviral therapy: a double-blind, placebo-controlled trial. *Psychosomatics* 2010;51:401-8. ([Abstract](#))
- Musselman DL, Lawson DH, Gumnick JF, et al. Paroxetine for the prevention of depression induced by high-dose interferon alfa. *N Engl J Med* 2001;344:961-6. ([Abstract](#))
- Pariante CM, Landau S, Carpinello B. Interferon alfa-induced adverse effects in patients with a psychiatric diagnosis. *N Engl J Med* 2002;347:148-9. ([Abstract](#))
- Piche T, Vanbiervliet G, Cherikh F, et al. Effect of ondansetron, a 5-HT3 receptor antagonist, on fatigue in chronic hepatitis C: a randomised, double blind, placebo controlled study. *Gut* 2005;54:1169-73. ([Abstract](#))

- Pockros PJ, Shiffman ML, Schiff ER, et al. Epoetin alfa improves quality of life in anemic HCV-infected patients receiving combination therapy. *Hepatology* 2004; 40:1450-8. ([Abstract](#))
- Poordad F, McCone J Jr, Bacon BR, et al. Boceprevir for untreated chronic HCV genotype 1 infection. *N Engl J Med* 2011;364:1195-206. ([Abstract](#))
- Raison CL, Woolwine BJ, Demetrashvili MF, et al. Paroxetine for prevention of depressive symptoms induced by interferon-alpha and ribavirin for hepatitis C. *Aliment Pharmacol Ther* 2007;25:1163-74. ([Abstract](#))
- Renault PF, Hoofnagle JH, Park Y, et al. Psychiatric complications of long-term interferon alfa therapy. *Arch Intern Med* 1987;147:1577-80. ([Abstract](#))
- Sammut S, Bethus I, Goodall G, Muscat R. Antidepressant reversal of interferon-alpha-induced anhedonia. *Physiol Behav* 2002;75:765-72. ([Abstract](#))
- Schaefer M, Engelbrecht MA, Gut O, et al. Interferon alpha [IFNalpha] and psychiatric syndromes: a review. *Prog Neuropsychopharmacol Biol Psychiatry* 2002;26:731-46. ([Abstract](#))
- Schaefer M, Schmidt F, Folwaczny C et al. Adherence and mental side effects during hepatitis C treatment with interferon alfa and ribavirin in psychiatric risk groups. *Hepatology* 2003;37:443-51. ([Abstract](#))
- Schaefer M, Heinz A, Backmund M. Treatment of chronic hepatitis C in patients with drug dependence: time to change the rules? *Addiction* 2004;99:1167-75. ([Abstract](#))
- Schafer A, Wittchen HU, Seufert J, Kraus MR. Methodological approaches in the assessment of interferon-alfa-induced depression in patients with chronic hepatitis C - a critical review. *Int J Methods Psychiatr Res* 2007;16:186-201. ([Abstract](#))
- Schaefer M, Hinzpeter A, Mohmand A, et al. Hepatitis C treatment in "difficult-to-treat" psychiatric patients with pegylated interferon-alpha and ribavirin: Response and psychiatric side effects. *Hepatology* 2007;46:991-8. ([Abstract](#))
- Schaefer M, Schwaiger M, Garkisch AS, et al. Prevention of interferon-alpha associated depression in psychiatric risk patients with chronic hepatitis C. *J Hepatol* 2005;42:793-8. ([Abstract](#))
- Schafer A, Wittchen HU, Seufert J, Kraus MR. Methodological approaches in the assessment of interferon-alfa-induced depression in patients with chronic hepatitis C - a critical review. *Int J Methods Psychiatr Res* 2007;16:186-201. ([Abstract](#))
- Schramm TM, Lawford BR, Macdonald GA, Cooksley WG. Sertraline treatment of interferon-alfa-induced depressive disorder. *Med J Aust*, 2000;173:359-61. ([Abstract](#))
- Seyam MS, Freshwater DA, O'Donnell K, Mutimer DJ. Weight loss during pegylated interferon and ribavirin treatment of chronic hepatitis C. *J Viral Hepat* 2005;12:531-5. ([Abstract](#))
- Shiffman ML, Salvatore J, Hubbard S, et al. Treatment of chronic hepatitis C virus genotype 1 with peginterferon, ribavirin, and epoetin alfa. *Hepatology* 2007;46:371-9. ([Abstract](#))
- Torriani FJ, Rodriguez-Torres M, Rockstroh JK, et al. Peginterferon Alfa-2a plus ribavirin for chronic hepatitis C virus infection in HIV-infected patients. *N Engl J Med* 2004;351:438-50. ([Abstract](#))
- Tran HA, Jones TL, Batey RG. The spectrum of thyroid dysfunction in an Australian hepatitis C population treated with combination Interferon-alpha 2-beta and Ribavirin. *BMC Endocr Disord* 2005;5:8. ([Abstract](#))
- Valentine AD, Meyers CA. Successful treatment of interferon-alpha-induced mood disorder with nortriptyline. *Psychosomatics* 1995;36:418-9. ([Abstract](#))

## 16. Extrahepatic Manifestations of Chronic HCV

*Karl-Philipp Puchner, Albrecht Böhlig and Thomas Berg*

### Introduction

Patients with chronic hepatitis C virus (HCV) infection are at risk of a great number of extrahepatic manifestations (EHMs) (Table 1) – up to 40-76% of patients infected with HCV develop at least one EHM during the course of the disease (Cacoub 2000, Cacoub 1999). EHMs may often be the first and only clinical sign of chronic hepatitis C infection. Evidence of HCV infection should always be sought out in cases of non-specific chronic fatigue and/or rheumatic, hematological, endocrine or dermatological disorders. The pathogenesis of EHM is still not fully understood, although most studies suggest that the presence of mixed cryoglobulinemia, particular lymphotropism of the virus, molecular mimicry and non-cryoglobulinemic autoimmune phenomena constitute the major pathogenic factors (Ferri 2007). Nevertheless, pathogenesis and epidemiology of many EHMs requires further investigation (Figure 1). Our aim is to give a brief insight into the epidemiology, pathogenesis, clinical relevance and therapeutic management of HCV-associated EHM (Zignego 2007a).

### Mixed cryoglobulinemia

Cryoglobulinemia refers to the presence of abnormal immunoglobulins in the serum, which have the unusual property of precipitating at temperatures below 37°C and redissolving at higher temperatures. The phenomenon of cryoprecipitation was first described in 1933 (Wintrobe 1933). Cryoglobulins (CGs) are nowadays classified, on the basis of their clonality, into three types (Table 2). Type II CG and type III CG, consisting of monoclonal and/or polyclonal immunoglobulins, are prevalent in patients with a chronic HCV infection, while type I CGs, consisting exclusively of monoclonal components, are mostly found in patients with lymphoproliferative disorders (multiple myeloma, B cell lymphoma, Waldenström macroglobulinaemia). Type II or type III mixed cryoglobulinemia is found in 19%-50% of patients with chronic HCV, but leads to clinical manifestations, through



vascular precipitation of immunocomplexes, in only 30% of them (Lunel 1994; Wong 1996). Asymptomatic mixed cryoglobulinemia, during the course of chronic HCV infection, may evolve into symptomatic disease. Patients with symptomatic mixed cryoglobulinemia exhibit higher cryoglobulin concentrations (cryocrit >3%) (Weiner 1998) and lower concentrations of complement factors C3 and C4. Thus CG-triggered complement activation may constitute a key incidence in cryoglobulinemia-derived pathogenesis. Factors that seem to favour the development of MC are female sex, age, alcohol intake (>50g/d), advanced liver fibrosis and steatosis (Lunel 1994, Wong 1996, Saadoun 2006).

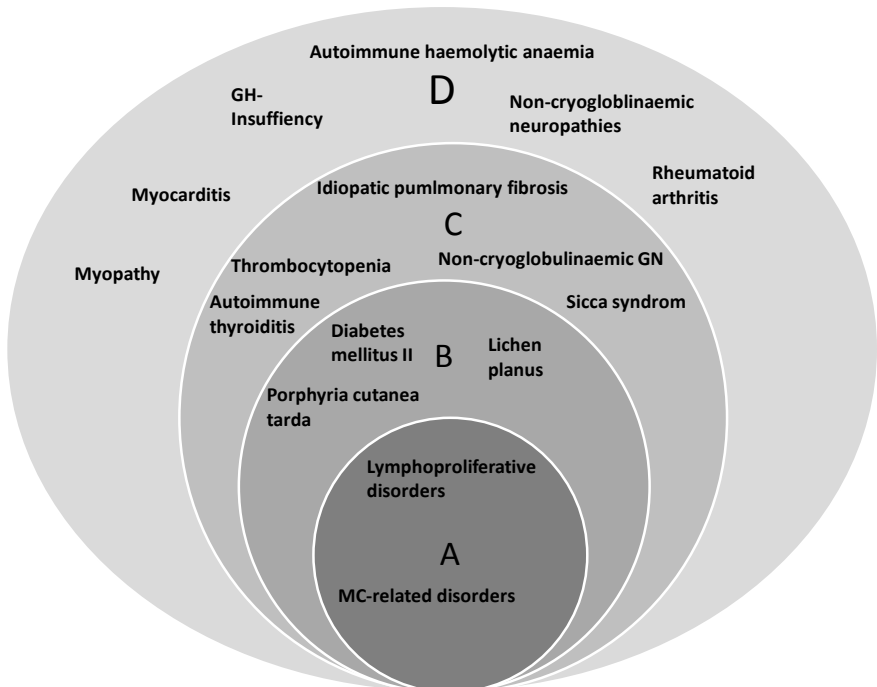
**Table 1. Extrahepatic manifestations of chronic hepatitis C infection.**

<b>Organ/System involved</b>	<b>Manifestation</b>
<b>Endocrine</b>	<ul style="list-style-type: none"> <li>• Autoimmune thyroidopathies (in particular, Hashimoto thyroiditis)</li> <li>• Insulin resistance/diabetes mellitus*</li> <li>• GH-insufficiency</li> </ul>
<b>Rheumatic disorders</b>	<ul style="list-style-type: none"> <li>• Mixed cryoglobulinemia*</li> <li>• Cryoglobulinemic vasculitis*</li> <li>• Peripheral neuropathy*</li> <li>• Membrano-proliferative glomerulonephritis (GN)*</li> <li>• Membranous GN*</li> <li>• Rheumatoid arthralgias/oligopolyarthritits</li> <li>• Rheumatoid factor positivity*</li> <li>• Sicca syndrome</li> </ul>
<b>Hematologic disorders</b>	<ul style="list-style-type: none"> <li>• Lymphoproliferative disorders/Non-Hodgkin Lymphomas*</li> <li>• Immune thrombocytopenic purpura (ITP)</li> <li>• Monoclonal gammopathies*</li> <li>• Autoimmune hemolytic anemia</li> </ul>
<b>Dermatologic disorders</b>	<ul style="list-style-type: none"> <li>• Palpable purpura</li> <li>• Porphyria cutanea tarda (PCT)</li> <li>• Lichen planus</li> <li>• Pruritus</li> </ul>
<b>Miscellaneous</b>	<ul style="list-style-type: none"> <li>• Chronic fatigue*, subclinical cognitive impairment, psychomotoric deceleration, symptoms of depression*</li> <li>• Myopathy</li> <li>• Cardiomyopathy/Myocarditis</li> <li>• Idiopathic pulmonal fibrosis</li> </ul>

\* Associations that rest upon strong epidemiological prevalence and/or clear pathogenetic mechanisms.

**Table 2. Types of cryoglobulinemia.**

Type	Clonality
Type I	Monoclonal immunoglobulins (IgG or IgM)
Type II	Polyclonal immunoglobulins (mainly IgG) and monoclonal IgM with rheumatoid factor activity (RF)
Type III	Polyclonal IgG and IgM



**Figure 1. Schematic representation of EHM categories (modified after Zignego 2007a).** A) Associations with strong epidemiological evidence and clear pathogenetic mechanisms; B) Associations with high prevalence, but unclear pathogenetic mechanisms; C) Associations for which the high prevalence in HCV collectives could be due to HCV infection and/or confounding factors; D) Anecdotal observations.

## Diagnosis

Detection of CG is carried out by keeping patient serum at 4°C for up to 7 days. After cryoprecipitate is visible, CG can be purified and characterized using immunofixation electrophoresis. In case of evidence of mixed cryoglobulinemia in HCV-positive patients, the presence of cryoglobulinemic syndrome must be sought. Vigilant monitoring is required, as asymptomatic mixed cryoglobulinemia patients may develop MC-related disorders in the course of the disease. The diagnosis of the MC syndrome is based on serologic, pathologic and clinical criteria (Table 3).

**Table 3. Diagnostic criteria of cryoglobulinemic syndrome.**

Serologic	Histopathologic	Clinical
<ul style="list-style-type: none"> <li>• C4 reduction</li> <li>• Positive rheumatoid factor (RF)</li> <li>• CGs type II or III</li> <li>• HCV antibodies</li> </ul>	<ul style="list-style-type: none"> <li>• Leukocytoclastic vasculitis</li> <li>• Infiltrates of monoclonal B-cells</li> </ul>	<ul style="list-style-type: none"> <li>• Purpura</li> <li>• Fatigue</li> <li>• Arthralgia</li> <li>• Membranoproliferative GN</li> <li>• Peripheral neuropathy</li> </ul>

In the presence of mixed CG, low C4 counts, leucocytoclastic vasculitis and purpura, a definite symptomatic MC can be diagnosed. Rheumatoid factor (RF) determination constitutes a reliable surrogate parameter for detection of CG. Finally, presence of CG may impair HCV RNA determination as viral RNA can accumulate in precipitated cryocrit (Colantoni 1997).

## Clinical presentation

HCV-related MC proceeds mostly asymptotically and has no significant influence on the course of chronic liver inflammation. On the other hand, symptomatic mixed cryoglobulinemia is associated with higher mortality (Ferri 2004).

### Systemic vasculitis

HCV-related vasculitis relies on a deposition of immunocomplexes containing CGs, complement and large amounts of HCV antigens in the small- and medium-sized blood vessels. HCV accumulates in the CG-immunoglobulins. Pathohistological findings reveal a leucocytoclastic vasculitis (Agnello 1997). The most common symptoms of mixed cryoglobulinemic vasculitis are weakness, arthralgia and purpura (the Meltzer and Franklin triad). Mixed cryoglobulinemic vasculitis may also lead to Raynaud's Syndrome and Sicca Syndrome, glomerulonephritis and peripheral neuropathy.

### Renal impairment

The predominant renal impairment associated with mixed cryoglobulinemia is the membranous proliferative glomerulonephritis (MPGN), characterized in most cases by proteinuria, mild hematuria and mild renal insufficiency. The presence of kidney impairment is considered to be a negative prognostic factor in the course of the disease (Ferri 2004). In 15% of patients, MC-related nephropathy may progress towards terminal chronic renal failure requiring dialysis (Tarantino 1995).

### Peripheral neuropathy

Peripheral neuropathy, on the basis of endoneural microangiopathy, constitutes a further typical complication of mixed cryoglobulinemia. MC-related neuropathy, presenting clinically as mononeuropathy or polyneuropathy, is mostly sensory and is characterized by numbness, burning skin crawling and pruritus, predominantly in the hands and feet (Tembl 1999, Lidove 2001). Epidemiological data from Italy suggests that peripheral neuropathy is the second most common symptom after the Meltzer and Franklin triad in patients with symptomatic HCV-associated mixed cryoglobulinemia (Ferri 2004).

## Cirrhosis

The causal association between CG and progression of liver fibrosis suggested by numerous authors has not been confirmed in a recently published 10-year prospective study. The 10-year rates of progression to cirrhosis were similar in cryoglobulinemic and non-cryoglobulinemic HCV-infected patients (Vigano 2007). With respect to this data, it is unlikely that mixed cryoglobulinemia constitutes an independent risk factor for the progression of liver fibrosis.

## Malignant lymphoproliferative disorders/NHL

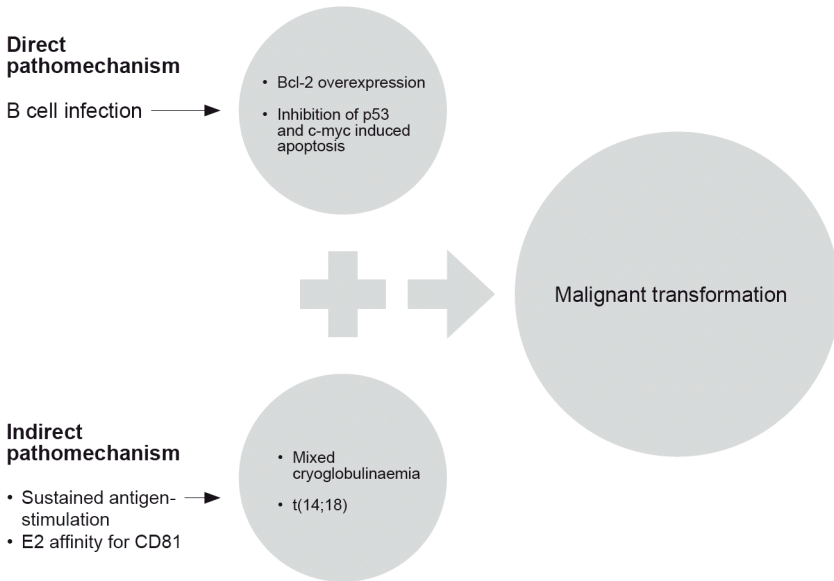
The association between infectious agents and potentially reversible “antigen driven” lymphoproliferative disorders, such as *Helicobacter pylori*-related gastric marginal zone B cell lymphoma has been known for many decades. Recent data suggest a causative association between HCV and Non-Hodgkin Lymphoma (NHL) (Mele 2003, Duberg 2005, Giordano 2007). HCV infection leads per se to a twofold higher risk of developing NHL (Mele 2003, Duberg 2005). The most prevalent HCV-associated lymphoproliferative disorders according to the REAL/WHO classification are: follicular lymphoma, B cell chronic lymphocytic leukemia/small lymphocyte lymphoma, diffuse large B cell lymphoma and marginal zone lymphoma, including the mucosa-associated lymphoid tissue lymphoma. Overall, marginal zone lymphoma appears to be the most frequently encountered low grade B cell lymphoma in HCV patients.

HCV-associated lymphoproliferative disorders (LPDs) are observed over the course of MC. 8-10% of mixed cryoglobulinemia type II evolve into B cell NHL after long-lasting infection. However, a remarkably high prevalence of B cell NHL was also found in HCV patients without mixed cryoglobulinemia (Silvestri 1997). Genetic predisposition and other factors seem to have a major impact on the development of LPDs in HCV-positive patients (Matsuo 2004).

## Etiology and pathogenesis of LPDs in patients with HCV infection

In the development of LPDs direct and indirect pathogenic HCV-associated factors (Figure 2) are seen. Sustained B cell activation and proliferation, noticed during chronic HCV infection, is an indirect pathogenic mechanism.

Direct pathogenic mechanisms are based on lymphotropic properties of HCV, hence on the very invasion of HCV into the B cells. HCV RNA sequences were first detected in mononuclear peripheral blood cells (Zignego 1992). Especially CD19+ cells seem to be permissive for certain HCV quasispecies (Roque Afonso 1999). Active replication of the HCV genome in B cells is associated with activation of anti-apoptotic gene bcl-2 and inhibition of p53 or c-Myc-induced apoptosis (Sakamuro 1995, Ray 1996). In this light, direct involvement of HCV in the immortalisation of B cells can be envisioned (Zignego 2000, Machida 2004).



**Fig 2. Pathomechanisms involved in the development of malignant lymphoproliferative disorders in patients with chronic HCV infection.** Indirect pathomechanism: Sustained antigen stimulation, like binding of viral envelope protein to CD81 receptor, leads to excessive B cell proliferation, which in turn favors development of mixed cryoglobulinemia and/or genetic aberrations, such as t(14;18) translocation. Direct pathomechanism: Viral infection of B cells, as viral replication in them may result in activation of proto-oncogenes (i.e., Bcl-2) and/or inhibition of apoptotic factors (i.e., p53, c-myc). One of the factors favoring this polyclonal B cell activation and proliferation is probably the HCV E2 protein, which binds specifically to CD81, a potent B cell activator (Cormier 2004).

## Treatment of lymphoproliferative disorders

Because of the close correlation between the level of viral suppression and improvement of HCV-associated extrahepatic symptoms, the most effective antiviral strategy should be considered when dealing with HCV-related extrahepatic diseases. The protease inhibitors boceprevir and telaprevir have been shown to improve significantly sustained virologic response rate in HCV type 1-infected patients when given in combination with peg-interferon plus ribavirin as compared to peg-interferon and ribavirin alone, and can be therefore regarded as the treatment of choice in HCV type 1-infected patients with extrahepatic manifestations. However, certain protease-inhibitor-associated contraindications, especially drug-drug interaction due to their metabolism via the CYP3A isoenzymes, have to be taken into account and all concomitant medications need to be assessed and adjusted. For further information, see the other HCV chapters.

### Mixed cryoglobulinemia

While asymptomatic MC per se does not constitute an indication for treatment, symptomatic mixed cryoglobulinemia should always be treated. Because asymptomatic cryoglobulinemia may evolve into symptomatic in the course of

disease, vigilant monitoring is required and introduction of antiviral therapy in terms of prophylaxis should be considered.

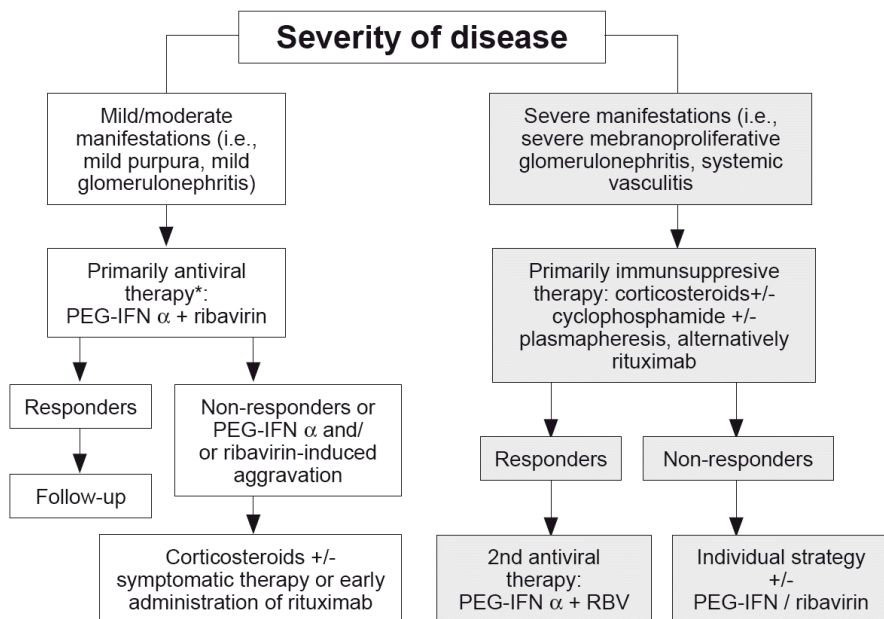
Because a causal correlation between HCV infection and mixed cryoglobulinemia has been established, the therapeutic approach of symptomatic mixed cryoglobulinemia should primarily concentrate on the eradication of the virus. Indeed, clinical improvement of MC is reported in 50 to 70% of patients receiving antiviral therapy with IFN  $\alpha$  and RBV and mostly correlates with a drastic reduction of HCV RNA concentrations (Calleja 1999). However, cryoglobulinemic vasculitis following successful antiviral treatment persists in a small collective (Levine 2005). IFN  $\alpha$  has been shown to be a promising therapeutic tool irrespective of virologic response. Due to its antiproliferative properties on IgM-RF producing B cells and stimulation of macrophage-mediated clearance of immunocomplexes, IFN  $\alpha$  may lead to clinical amelioration even in virological nonresponders. Therefore, therapeutic success should be primarily evaluated on the basis of clinical response irrespective of virologic response. In case of treatment failure of antiviral therapy and/or fulminant manifestations, contraindications or severe side effects, alternative therapeutic strategies such as cytostatic immunosuppressive therapy and/or plasmapheresis should be considered (Craxi 2008) (Figure 3, Table 4). Recent data show rituximab as an effective and safe treatment option for MC even in advanced liver disease. Moreover, B-cell depletion has been shown to improve cirrhotic syndrome by mechanisms that remain to be further studied (Petarca 2010).

### **Systemic vasculitis**

In cases of severe systemic vasculitis, initial therapy with rituximab, a monoclonal chimeric antibody against CD20 B cell specific antigen, is suggested. Its efficacy and safety have also been demonstrated in patients with symptomatic MC resistant to IFN  $\alpha$  therapy, even though HCV RNA increased approximately twice the baseline levels in responders (Sansono 2003). In light of this, combined application of rituximab with PEG-IFN  $\alpha$  plus ribavirin in cases of severe mixed cryoglobulinemia-related vasculitis resistant to antiviral therapy seems to be the optimal therapeutic strategy, achieving amelioration of MC-related symptoms and a complete eradication of HCV in responders (Saadoun 2008). In severe rituximab-refractory mixed cryoglobulinaemia-related vasculitis or acute manifestations, cycles of plasma exchange plus corticosteroids and eventually cyclophosphamide are indicated. Further studies showed that low dose interleukin-2 can lead to clinical improvement of vasculitis and has immunologic effects such as recovery of regulatory T cells (Saadoun 2011).

### **Peripheral neuropathy**

Effectiveness of antiviral therapy on cryoglobulinemic-induced peripheral neuropathy is still being debated. While HCV-related peripheral neuropathy responsive to antiviral therapy with IFN  $\alpha$  and ribavirin in 4 patients with chronic HCV has been reported (Koskinas 2007), several authors report on an aggravation of cryoglobulinemic neuropathy or even *de novo* occurrence of demyelinating polyneuropathy during IFN  $\alpha$  and PEG-IFN  $\alpha$  treatment (Boonyapist 2002, Khiani 2008). Therefore, application of IFN  $\alpha$  in presence of HCV-related neuropathy requires a cautious risk-benefit assessment.



**Figure 3. Therapy algorithm for symptomatic HCV-related mixed cryoglobulinemia (modified from Craxi 2008).** Antiviral therapy, on the basis of PEG-IFN  $\alpha$  and ribavirin plus/minus protease inhibitors, is regarded as first line therapy in cases of mild/moderate manifestations. In case of contraindications, patients should be treated primarily with corticosteroids. Non-response to antiviral therapy or drug-induced aggravation makes application of corticosteroids essential. Long-term therapy with corticosteroids may result in elevation of viral load and progression of hepatic disease. In light of this, rituximab represents an attractive alternative, because in this case, drug-induced viral load elevation is minor. In patients with severe manifestations, treatment should focus on immunosuppression ( $\pm$  plasmapheresis). Due to its excellent immunosuppressive properties and relatively mild side effect profile, use of rituximab should be favored. In case of good clinical response, consecutive antiviral treatment with PEG-IFN  $\alpha$  and ribavirin may serve as maintenance therapy. Therapy refractory cases require individual treatment according to the particular center's experience. Supplementation of therapeutic strategy with antiviral therapy should be considered.

As eradication of *Helicobacter pylori* may lead to complete remission of MALT lymphoma, antiviral therapy can lead to regression of low-grade NHL in patients with HCV-related malignant lymphoproliferative disorders. PEG-IFN  $\alpha$  plus ribavirin ( $\pm$  protease inhibitors) should be regarded in such cases as first-line therapy (Giannelli 2003, Vallisa 2005). Thus, remission of the hematologic disorders is closely associated with virologic response or rather achievement of sustained virologic response. Effectiveness of IFN  $\alpha$  in this context should be ascribed primarily to the drug's antiviral and less to its anti-proliferative properties.

**Table 4. Treatment of cryoglobulinemia-related disorders in patients with chronic HCV infection.**

Author	Patients	Treatment	Result
Zuckerman	N=9 symptomatic-MC non-responders to IFN $\alpha$ monotherapy	IFN $\alpha$ 3x/wk + ribavirin 15 mg/kg/d	CGs undetectable within 6 weeks in 7/9 patients; clinical improvement in 9/9 within 10 weeks
Sansonno	N=20 MC vasculitis and peripheral neuropathy resistant to IFN $\alpha$ monotherapy	Rituximab 375 mg/m <sup>2</sup> / 4x/wk	16 patients complete clinical response; 12 sustained response throughout follow-up. Viremia increase in responders.
Saadoun	N=16 MC vasculitis in relapsers or non- responders to IFN $\alpha$ /PEG-IFN $\alpha$ + RBV	Rituximab 375 mg/m <sup>2</sup> / 4x/wk; PEG-IFN $\alpha$ 1.5 ug/kg/wk + RBV (600-1200 mg/d) for 12 months	10/16 complete clinical response; CGs and RNA HCV undetectable in responders
Bruchfeld	N=7 HCV-related renal manifestations (2/7 MC-related)	IFN $\alpha$ + low-dose ribavirin (200-600 mg) or PEG-IFN $\alpha$ + low-dose ribavirin	Improvement of GRF and proteinuria in 4/7 patients and sustained viral response in 5/7.
Roccatello	N=6 MC systematic manifestations predominantly renal (5/6)	Rituximab 375 mg/m <sup>2</sup> /4x/wk + rituximab 375 mg/m <sup>2</sup> 1 month and 2 months later	Decrease of cryocrit and proteinuria at months 2, 6, 12.
Koskinas	N=4 MC patients with severe sensory-motor polyneuropathy	INF $\alpha$ -2b 1.5ug/kg/wk + ribavirin 10.6 mg/kg/d for 48 weeks	Significant improvement of neurological parameters in 4/4; undetectable HCV RNA and lower CG levels in 3/4 at the end of therapy.

Treatment of HCV-infected patients with high-grade NHL should be based on cytostatic chemotherapy. HCV infection does not constitute a contraindication for cytostatic chemotherapy. Unlike HBV infection, antiviral prophylaxis before chemotherapy introduction is not obligatory. Chemotherapy may lead to a substantial increase in viremia. Consecutive exacerbation of the infection, making discontinuation of chemotherapy mandatory, is unlikely to occur. However, treatment-related liver toxicity is more frequent in HCV-positive NHL and is often associated with severe hepatic manifestations (Besson 2006, Arcaini 2009). Current data suggest that antiviral treatment may serve as maintenance therapy for achieving sustained remission of NHL after chemotherapy completion (Gianelli 2003).



## Further hematological manifestations

### HCV-associated thrombocytopenia

Thrombocytopenic conditions (platelet counts below  $150 \times 10^3/\mu\text{L}$ ) are often observed in patients with chronic hepatitis C and result mainly from advanced liver fibrosis and manifest cirrhosis (Wang 2004). Lack of hepatic-derived thrombopoietin can *inter alia* be recognized as an important causal factor (Afdhal 2008). As HCV RNA can be abundant in platelets (Takehara 1994) and megakaryocytes of thrombocytopenic patients, direct cytopathic involvement of HCV can be hypothesized (Bordin 1995, De Almeida 2004). Furthermore, it has been suggested that exposure to HCV may be a causative factor for the production of platelet-associated immunoglobulins, inducing thrombocytopenia through a similar immunological mechanism to that operating in immune thrombocytopenic purpura (ITP) (Aref 2009). There is a high HCV prevalence in patients with ITP (García-Suaréz 2000), and these patients exhibit diverse characteristics to HCV-negative patients with ITP, which supports the hypothesis of direct viral involvement in the development of thrombocytopenia (Rajan 2005).

There is no consensus regarding the optimum treatment of HCV-related ITP. Along with classical therapeutic approaches such as corticosteroids, intravenous immunoglobulins and splenectomy, antiviral therapy constitutes another option. A substantial increase of platelets after application of antiviral therapy is registered in a significant percentage of patients with HCV-related ITP (Iga 2005), although evidence from further studies is required to confirm this hypothesis. However, caution is recommended in thrombocytopenic patients treated with PEG-IFN  $\alpha$  plus ribavirin, as significant aggravation of HCV-related ITP may occur on this regimen (Fattovich 1996). On the other hand, long-term use of steroids or immunosuppressive drugs respectively is limited by an increased risk of fibrosis progression or a substantial elevation of virus. A new orally active thrombopoietin receptor agonist, eltrombopag, may be used in thrombocytopenic HCV patients in the future. Its efficacy was recently documented in patients with HCV-related ITP (Bussel 2007) as well as in HCV-positive patients suffering from thrombocytopenia due to cirrhosis (McHutchison 2007). However in a recent study treating patients with eltrombopag in combination with PEG-IFN  $\alpha$  and ribavirin, portal vein thrombosis was observed in a number of patients as an unexpected complication (Afdhal 2011). In case of refractory disease or aggravation during the course of antiviral therapy, rituximab should be considered (Weitz 2005).

### HCV-related autoimmune hemolytic anemia

Interpretation of autoimmune hemolytic anemia (AHA) as a possible EHM is based mainly on a few well-documented case reports (Chao 2001, Fernández 2006, Srinivasan 2001). AHA has been frequently observed in HCV patients treated with IFN  $\alpha$  with and without ribavirin and consequently recognized as a possible side effect of antiviral treatment (De la Serna-Higuera 1999, Nomura 2004). Recently, a large-scale epidemiological study confirmed a high incidence of AHA in HCV patients undergoing antiviral treatment. However, the incidence rate of AHA in treatment-naïve HCV patients was statistically insignificant (Chiao 2009). In this light, there is, for the time being, little evidence for regarding AHA as a possible EHM of chronic HCV infection.

## HCV-related glomerulonephritis

Glomerulonephritis (GN) constitutes a rare extrahepatic complication of chronic HCV. Predominant manifestations are cryoglobulinemic or non-cryoglobulinemic membranous proliferative GN and mesangioproliferative GN. Far less common is membranous nephropathy (Arase 1998). Other forms of GN do not correlate significantly with HCV infection (Daghestani 1999). Microhematuria and proteinuria are among the most frequent medical findings in patients with membranous proliferative GN. Approximately 50% of patients exhibit a mild renal insufficiency. 20-25% may present an acute nephritic syndrome (hematuria, hypertension and proteinuria), as in 25% of patients nephrotic syndrome represents the initial manifestation. In contrast, >80% of patients with HCV-related membranous nephropathy suffer primarily a nephrotic syndrome (Doutrelepon 1993, Rollino 1991). The mesangioproliferative form proceeds mostly asymptotically, with typical findings such as hematuria and proteinuria often missing (McGuire 2006).

The pathomechanism of renal impairment is yet not fully understood. It can be hypothesized that glomerular injury is primarily caused by a deposition of circulating immunocomplexes containing anti-HCV antibodies, HCV antigens and complement factors. Formation and deposition of such immunocomplexes occurs also in the absence of CGs. HCV-proteins in glomerular and tubulointerstitial structures are immunohistologically detectable in approximately 70% of patients with chronic HCV (Sansonno 1997). Further possible pathomechanisms of glomerular injury encompass formation of glomerular autoantibodies, glomerular impairment due to chronic hepatic injury, or IgM overproduction with consecutive glomerular IgM deposition as result of HCV-triggered cryoglobulinemia type II. GN prevalence in HCV patients is estimated at 1.4% and is comparably high due to its prevalence among blood donors (Paydas 1996).

HCV-induced GN has mostly a benign prognosis (Daghestani 1999). 10-15% of patients with nephritic syndrome experience spontaneous complete or partial remission. Frequently persisting mild proteinuria exhibits no tendency to progression. It is estimated that only approximately 15% of the patients with HCV-related GN develop terminal renal failure requiring dialysis (Tarantino 1995). Nevertheless, presence of kidney impairment is considered to be a negative prognostic factor for long-term survival (Ferri 2004).

Patients with HCV-related GN should be primarily treated with antivirals. In cases of mild renal impairment, sustained viral response normally leads to amelioration of proteinuria or even full remission of GN. With high baseline viremia and advanced renal insufficiency, antiviral therapy is subject to certain limitations (Sabry 2002). Despite amelioration of proteinuria achieved after antiviral therapy, significant improvement of renal function is often lacking (Alric 2004). PEG-IFN and ribavirin dosage must be cautiously adjusted to glomerular filtration rate (GFR), in order to mainly prevent ribavirin accumulation with consecutive hemolytic anemia (Fabrizi 2008). Even in advanced renal failure, use of ribavirin is recommended due to the superior efficacy of combination therapy vs. IFN monotherapy (Bruchfeld 2003, Baid-Agrawal 2008). In patients with GFR <30 ml/min ribavirin dosage should not exceed 600 mg/week. Careful dosage augmentation may be undertaken in the absence of side effects. Ribavirin dosages

up to 100-400 mg/day was done under vigilant blood level monitoring in dialysis patients. Ribavirin-induced hemolytic anemia was efficiently treated by administration of erythropoietin and erythrocyte concentrates (van Leusen 2008). As determination of ribavirin blood levels is not an established laboratory procedure, implementation of such a therapeutic approach in clinical routine remains arduous. No dose reduction is required with respect to renal impairment for the two licensed protease inhibitors boceprevir and telaprevir (see also Chapters 14 and 15).

Fulminant manifestations with impending acute renal failure make administration of corticosteroids, immunosuppressive drugs such as cyclophosphamide and eventually plasmapheresis necessary (Garini 2007, Margin 1994). In cases of simultaneous bone marrow B cell infiltration and/or resistance to conventional therapy, application of rituximab is indicated (Roccatello 2004). Rituximab may be used as an alternative first line therapy in severe renal manifestations (Roccatello 2008). Antiviral and immunosuppressive therapy should always be supplemented with ACE inhibitors or AT1 receptor antagonists (Kamar 2006).

## Endocrine manifestations

Thyroid disease is found more commonly in patients with chronic HCV infection than in the general population. About 13% of HCV-infected patients have hypothyroidism and up to 25% have thyroid antibodies (Antonelli 2004). There is also evidence that IFN  $\alpha$  may induce thyroid disease or unmask preexisting silent thyroidopathies (Graves disease, Hashimoto thyroiditis) (Prummel 2003). In addition, some studies suggest that thyroid autoimmune disorders were significantly present in patients with chronic hepatitis C during but not before IFN  $\alpha$  therapy (Marazuela 1996, Vezali 2009). Therefore, the role of chronic hepatitis C infection per se in the development of thyroid disorders remains to be determined. The presence of autoantibodies against thyroid with/without clinical manifestations increases the risk of developing an overt thyroiditis significantly during antiviral therapy. Therefore, monitoring of the thyroid function should be performed during treatment.

Association between chronic HCV infection and development of insulin resistance and diabetes mellitus has been discussed in the past (Knobler 2000; Mason 1999, Hui 2003, Mehta 2003). In the meantime, a causal association is backed up by studies demonstrating that antiviral therapy with consecutive sustained viral response correlates with improved diabetic metabolic status and resolution of insulin resistance (Kawaguchi 2007). A recently published meta-analysis of retrospective and prospective studies confirms a high risk for the development of diabetes mellitus type II in patients with chronic HCV infection (OR=1.68, 95%, CI 1.15-2.20) (White 2008). Viral induction of insulin resistance seems to be HCV-specific, as prevalence of diabetes mellitus in HBV-infected patients is significantly lower (White 2008, Imazeki 2008). The pathomechanism of HCV-induced insulin resistance is yet not fully understood. It has been suggested that the appearance of insulin resistance could correlate with certain genotypes of HCV. Furthermore, HCV-dependent upregulation of cytokine suppressor SOC-3 may be responsible for the induction of cell desensitisation towards insulin. Insulin

resistance in turn represents an independent risk factor for progression of liver fibrosis in patients with chronic HCV infection (Moucari 2008, Kawaguchi 2004).

Finally, a link between HCV, growth hormone (GH) insufficiency and low insulin-like growth factor (IGF-1) has been hypothesized. Reduced GH secretion could be the result of a direct inhibitory effect of HCV infection at the level of the pituitary or hypothalamus (Plöckinger 2007).

## **Dermatologic and miscellaneous manifestations**

A multitude of cutaneous disorders has been sporadically associated with chronic HCV infection (Hadziyannis 1998). Epidemiologic studies have confirmed the existence of a strong correlation between the sporadic form of porphyria cutanea tarda (PTC) and HCV, though the presence of HCV in PTC patients seems to be subject to strong regional factors. Indeed, HCV prevalence in PTC patients is higher than 50% in Italy, while only 8% in Germany (Fargion 1992, Stölzel 1995).

Strong evidence of a close association between HCV and lichen planus was provided by studies performed in Japan and southern Europe (Nagao 1995, Carozzo 1996), yet these observations do not apply to all geographic regions (Ingafou 1998). HLA-DR6 has been recognized as a major predisposing factor for development of lichen planus in HCV-positive patients. One hypothesis suggests that geographical fluctuation of HLA-DR6 is responsible for the diverse prevalence among HCV patients (Gandolfo 2002).

Idiopathic pulmonary fibrosis (IPF) represents potentially an EHM, as prevalence of anti-HCV in patients with this disease is notably high (Ueda 1992). Interestingly, alveolar lavage in therapy-naïve HCV patients yielded frequent findings consistent with a chronic alveolitis. Alveolar lavage in the same patients after completion of antiviral therapy showed a remission of inflammatory activity (Yamaguchi 1997). Involvement of CGs in the genesis of IPF is also probable (Ferri 1997).

Numerous central nervous manifestations have been described in association with HCV infection. Cryoglobulinemic or non-cryoglobulinemic vasculitis of cerebral blood vessels may be responsible for the relatively high prevalence of both ischemic and hemorrhagic strokes in young HCV-positive patients (Cacoub 1998). Transverse myelopathies leading to symmetrical paraparesis and sensory deficiency have been recently observed (Aktipi 2007).

Furthermore, chronic HCV infection is associated with significant impairment of quality of life. 35-68% of HCV patients suffer from chronic fatigue, subclinical cognitive impairment and psychomotor deceleration. Symptoms of depression are evident in 2-30% of HCV patients examined (Perry 2008, Forton 2003, Carta 2007). Psychometric as functional magnetic resonance spectroscopy studies suggest altered neurotransmission in HCV-positive groups (Weissenborn 2006, Forton 2001). In addition, significant tryptophan deficiency is detectable in patients with chronic HCV infection. Resulting deficiency of the tryptophan-derived serotonin is likely to favor an occurrence of depressive disorders. There is evidence to suggest that antiviral therapy can lead to elevation of tryptophan blood levels and thus contribute to amelioration of depressive symptoms in HCV patients (Zignego 2007c).

Occasionally, chronic HCV infection has been seen in association with cardiac pathologies such as chronic myocarditis and dilatative/hypertrophic

cardiomyopathy. Pathogenesis seems to rely on genetic predisposition and is assumed to be immunologically triggered (Matsumori 2000).

## References

- Afdhal N, McHutchison J, Brown R, Jacobson I, Manns M, Poordad F, et al. Thrombocytopenia associated with chronic liver disease. *J Hepatol* 2008;48:1000-7. ([Abstract](#))
- Afdhal NH, Dusheiko G, Giannini EG, et al. Final Results of ENABLE 1, a Phase 3, Multicenter Study of Eltrombopag as an Adjunct for Antiviral Treatment of Hepatitis C Virus-Related Chronic Liver Disease Associated With Thrombocytopenia. *Hepatology* 2011;54:1427-8.
- Agnello V, G. Ábel. Localization of hepatitis C virus in cutaneous vasculitic lesions in patients with type II cryoglobulinemia. *Arthritis Rheumatism* 1997;40:2007-2015. ([Abstract](#))
- Aktipi KM, Ravaglia S, Ceroni M. Severe recurrent myelitis in patients with hepatitis C virus infection. *Neurology* 2007;68:468-9. ([Abstract](#))
- Alric L, Plaisier E, Thébault S, Péron JM, Rostaing L, Pourrat J, et al. Influence of antiviral therapy in hepatitis C virus-associated cryoglobulinemic MPGN. *Am J Kidney Dis* 2004;43:617-23. ([Abstract](#))
- Antonelli A, Ferri C, Pampana A, et al. Thyroid disorders in chronic hepatitis C. *Am J Med* 2004;117:10-3. ([Abstract](#))
- Arase Y, Ikeda K, Murashima N, Chayama K, Tsubota A, Koida I, et al. Glomerulonephritis in autopsy cases with hepatitis C virus infection. *Intern Med* 1998;37:836-40. ([Abstract](#))
- Arcaini L, Merli M, Passamonti F, Bruno R, Brusamolino E, Sacchi P, et al. Impact of treatment-related liver toxicity on the outcome of HCV-positive non-Hodgkin's lymphomas. 2010;85:45-50. ([Abstract](#))
- Aref S, Sleem T, El Menshawly N, Ebrahiem L, Abdella D, Fouda M, et al. Antiplatelet antibodies contribute to thrombocytopenia associated with chronic hepatitis C virus infection. *Hematology* 2009;14:277-81. ([Abstract](#))
- Baid-Agrawal S, Pascual M, Moradpour D, Frei U, Tolkoff-Rubin N. Hepatitis C virus infection in haemodialysis and kidney transplant patients. *Rev Med Virol* 2008;18(2):97-115. ([Abstract](#))
- Besson C, Canioni D, Lepage E, Pol S, Morel P, Lederlin P, et al. Characteristics and outcome of diffuse large B-cell lymphoma in hepatitis C virus-positive patients in LNH 93 and LNH 98 Groupe d'Etude des Lymphomes de l'Adulte programs. *J Clin Oncol* 2006;24:953-60. ([Abstract](#))
- Boonyapisit K, Katirji B. Severe exacerbation of hepatitis C-associated vasculitic neuropathy following treatment with interferon alpha: a case report and literature review. *Muscle Nerve* 2002;25:909-13. ([Abstract](#))
- Bordin G, Ballare M, Zigrossi P, Bertoncelli MC, Paccagnino L, et al. A laboratory and thrombokinetic study of HCV-associated thrombocytopenia: a direct role of HCV in bone marrow exhaustion? *Clin Exp Rheumatol* 1995;Suppl 13:S39-43. ([Abstract](#))
- Bruchfeld A, Lindahl K, Stahle L, Schvarcz R. Interferon and ribavirin treatment in patients with hepatitis C-associated renal disease and renal insufficiency. *Nephrol Dial Transplant* 2003;18:1573-80. ([Abstract](#))
- Bussel JB, Cheng G, Saleh MN, Psaila B, Kovaleva L, Meddeb B, et al. Eltrombopag for the treatment of chronic idiopathic thrombocytopenic purpura. *New Engl J M* 2007;357:2237-47. ([Abstract](#))
- Cacoub P, Sbai A, Hausfater P, et al. Central nervous system involvement in hepatitis C virus infection. *Gastroenterol Clin Biol* 1998;22:631-33. ([Abstract](#))
- Cacoub P, Poynard T, Ghillani P, et al. Extrahepatic manifestations of chronic hepatitis C. MULTIVIRC group. *Multidepartment Virus C. Arthritis Rheum* 1999;42:2204-12. ([Abstract](#))
- Cacoub P, Renou C, Rosenthal E, et al. Extrahepatic manifestations associated with hepatitis C virus infection. A prospective multicenter study of 321 patients. *Groupe d' Etude et de Recherche en Médecine Interne et Maladies Infectieuses sur le Virus de l'Hépatite C. Médecine* 2000;79:47-56. ([Abstract](#))
- Calleja JL, Albillos A, Moreno-Otero R, et al. Sustained response to interferon-alpha or to interferon-alpha plus ribavirin in hepatitis C virus-associated symptomatic mixed cryoglobulinaemia. *Aliment Pharmacol Ther* 1999;13:1179-86. ([Abstract](#))

- Carrozzo M, Gandolfo S, Carbone M, Colombatto P, Broccoletti R, Garzino-Demo P, et al. Hepatitis C virus infection in Italian patients with oral lichen planus: a prospective case-control study. *J Oral Pathol Med* 1996;25:527-33. ([Abstract](#))
- Carta MG, Hardoy MC, Garofalo A, Pisano E, Nonnoi V, Intilla G, et al. Association of chronic hepatitis C with major depressive disorders: irrespective of interferon-alpha therapy. *Clin Pract Epidemiol Ment Health* 2007;3:22. ([Abstract](#))
- Chao TC, Chen CY, Yang YH, et al. Chronic hepatitis C virus infection associated with primary warm-type autoimmune hemolytic anemia. *J Clin Gastroenterol* 2001;33:232-33. ([Abstract](#))
- Chiao EY, Engels EA, Kramer JR, Pietz K, Henderson L, Giordano TP, Landgren O. Risk of immune thrombocytopenic purpura and autoimmune hemolytic anemia among 120 908 US veterans with hepatitis C virus infection. *Arch Intern Med* 2009;169:357-63. ([Abstract](#))
- Colantoni A, De Maria N, Idilman R, Van Thiel DH. Polymerase chain reaction for the detection of HCV-RNA: cryoglobulinaemia as a cause for false negative results. *Ital J Gastroenterol Hepatol* 1997;29:273-77. ([Abstract](#))
- Cormier EG, Tsamis F, Kajumo F, Durso RJ, Gardner JP, Dragic T. CD81 is an entry coreceptor for hepatitis C virus. *Proc Natl Acad Sci US* 2004;101:7270-4. ([Abstract](#))
- Craxi A, Laffi G, Zignego AL. Hepatitis C virus (HCV) infection: a systemic disease. *Mol Aspects Med* 2008;29:85-95. ([Abstract](#))
- Daghestani L, Pomeroy C. Renal manifestations of hepatitis C infection. *Am J Med* 1999;106:347-54. ([Abstract](#))
- De Almeida AJ, Campos-de-Magalhaes M, Okawa MY, Vieira de Oliveira R, et al. Hepatitis C virus-associated thrombocytopenia: a controlled prospective, virological study. *Ann Hematol* 2004;83:434-40. ([Abstract](#))
- De la Serna-Higuera C, Bárcena-Marugán R, Sanz-de Villalobos E. Hemolytic anemia secondary to alpha-interferon treatment in a patient with chronic C hepatitis. *J Clin Gastroenterol* 1999;28:358-9. ([Abstract](#))
- Doutrelepont J-M, Adler M, Willems M, Durez P, Yap SH. Hepatitis C virus infection and membranoproliferative glomerulonephritis. *Lancet* 1993;341:317. ([Abstract](#))
- Duberg AS, Nordström M, Törner A, Reichard O, Strauss R, Janzon R, et al. Non-Hodgkin's lymphoma and other nonhepatic malignancies in Swedish patients with hepatitis C virus infection. *Hepatology* 2005;41:652-59. ([Abstract](#))
- Fabrizi F, Lunghi G, Messa P, Martin P. Therapy of hepatitis C virus-associated glomerulonephritis: current approaches. *J Nephrol* 2008;21:813-25. ([Abstract](#))
- Fargion S, Piperno A, Cappellini MD, et al. Hepatitis C virus and porphyria cutanea tarda: evidence of a strong association. *Hepatology* 1992;16:1322-6. ([Abstract](#))
- Fattovich G, Giustina G, Favarato S, Ruol A. A survey of adverse events in 11,241 patients with chronic viral hepatitis treated with alpha interferon. *J Hepatol* 1996;24:38-47. ([Abstract](#))
- Fernández A. An unusual case of autoimmune hemolytic anemia in treatment naïve hepatitis C virus infection. *Hematology* 2006;11:385-87. ([Abstract](#))
- Ferri C, La Civita L, Fazzi P, Solfanelli S, Lombardini F, Begliomini E, et al. Intestinal lung fibrosis and rheumatic disorders in patients with hepatitis C virus infection. *Br J Rheumatol* 1997;36:360-65. ([Abstract](#))
- Ferri C, Sebastiani M, Guiggiolo D, Cazzato M, Longombardo G, Antonelli A, et al. Mixed cryoglobulinaemia: demographic, clinical, and serologic features and survival in 231 patients. *Semin Arthritis Rheum* 2004;33:355-74. ([Abstract](#))
- Ferri C, Antonelli A, Mascia M.T, et al. B cells and mixed cryoglobulinemia. *Autoimmun Rev* 2007;7:114-20. ([Abstract](#))
- Forton DM, Allsop JM, Main J, et al. Evidence for a cerebral effect of the hepatitis C virus. *Lancet* 2001;358:38-9. ([Abstract](#))
- Forton DM, Taylor-Robinson SD, Thomas HC. Cerebral dysfunction in chronic hepatitis C infection. *J Viral Hepat* 2003;10:81-6. ([Abstract](#))
- Gandolfo S, Carrozzo M. Lichen planus and hepatitis C virus infection. *Minerva Gastroenterol Dietol* 2002;48:89. ([Abstract](#))
- García-Suárez J, Burgaleta C, Hernanz N, Albarran F, Tobaruela P, Alvarez-Mon M. HCV-associated thrombocytopenia: clinical characteristics and platelet response after recombinant alpha2b-interferon therapy. *Br J Haematol* 2000;110:98-103 ([Abstract](#))
- Garini G, Allegri L, Lannuzzella F, Vaglio A, Buzio C. HCV-related cryoglobulinemic glomerulonephritis: implications of antiviral and immunosuppressive therapies. *Acta Biomed* 2007;78:51-9. ([Abstract](#))

- Giannelli F, Moscarella S, Giannini C, Caini P, Monti M, et al. Effect of antiviral treatment in patients with chronic HCV infection and t(14;18) translocation. *Blood* 2003;102:1196-201. (Abstract)
- Giordano TP, Henderson L, Landgren O, Chiao EY, Kramer JR, El-Serag H, Engels EA. Risk of non-Hodgkin lymphoma and lymphoproliferative precursor diseases in US veterans with hepatitis C virus. *JAMA* 2007;297:2010-7. (Abstract)
- Hadziyannis SJ. Skin diseases associated with hepatitis C virus infection. *J Eur Acad Dermatol Venereol* 1998;10:12-21. (Abstract)
- Hui JM, Sud A, Farrell GC, Bandara P, et al. Insulin resistance is associated with chronic hepatitis C virus infection and fibrosis progression. *Gastroenterology* 2003;125:1695-704. (Abstract)
- Iga D, Tomimatsu M, Endo H, Ohkawa S-I, Yamada O. Improvement of thrombocytopenia with disappearance of HCV RNA in patients treated by interferon- $\alpha$  therapy: possible etiology of HCV-associated immune thrombocytopenia. *Eur J Haematol* 2005;75:417-23. (Abstract)
- Imazeki F, Yokosuka O, Fukai K, Kanda T, Kojima H, Saisho H. Prevalence of diabetes mellitus and insulin resistance in patients with chronic hepatitis C: comparison with hepatitis B virus-infected and hepatitis C virus-cleared patients. *Liver international* 2008;28:355-62. (Abstract)
- Ingafou M, Porter SR, Scully C, Teo CG. No evidence of HCV infection or liver disease in British patients with oral lichen planus. *Int J Oral Maxillofac Surg* 1998;27:65-6. (Abstract)
- Kamar N, Rostaing L, Alric L. Treatment of hepatitis C-virus-related glomerulonephritis. *Kidney Int* 2006;69:436-9. (Abstract)
- Kawaguchi T, Yoshida T, Harada M, Hisamoto T, Nagao Y, et al. Hepatitis C virus down-regulates insulin receptor substrates 1 and 2 through up-regulation of suppressor of cytokine signaling 3. *Am J Pathol* 2004;165:1499-508. (Abstract)
- Kawaguchi T, Ide T, Taniguchi E, et al. Clearance of HCV improves insulin resistance,  $\beta$ -cell function, and hepatic expression of insulin receptor substrates 1 and 2. *Am J Gastroenterol* 2007;102:1-7. (Abstract)
- Khiani V, Kelly T, Adeel S, Jensen D, Mohanty SR. Acute inflammatory demyelinating polyneuropathy associated with pegylated interferon  $\alpha$  2a therapy for chronic hepatitis C virus infection. *World J Gastroenterol* 2008;14:318-21. (Abstract)
- Knobler H, Schihmanter R, Zifroni A, Fenakel G, Schattner A. Increased risk of diabetes in noncirrhotic patients with chronic hepatitis C virus infection. *Mayo Clin Proc* 2000;75:355-9. (Abstract)
- Koskinas J, Kilidireas C, Karandreas N, Kountouras D, Savvas S, et al. Severe hepatitis C virus-related cryoglobulinaemic sensory-motor polyneuropathy treated with pegylated interferon- $\alpha$ 2b and ribavirin: clinical, laboratory and neurophysiological study. *Liver Int* 2007;27:414-20. (Abstract)
- Levine JW, Gota C, Fessler BJ, et al. Persistent cryoglobulinemic vasculitis following successful treatment of hepatitis C virus. *J Rheumatol* 2005;32:1164-7. (Abstract)
- Lidove O, Cacoub P, Maisonneuve T, Servan J, Thibault V, Piette JC, et al. Hepatitis C virus infection with peripheral neuropathy is not always associated with cryoglobulinaemia. *Ann Rheum Dis* 2001;60:290-2. (Abstract)
- Lunel F, Musset L, Cacoub P, Franguel L, Cresta P, Perri M, et al. Cryoglobulinemia in chronic liver diseases: role of hepatitis C virus and liver damage. *Gastroenterology* 1994;106:1291-300. (Abstract)
- Machida K, Cheng KT, Sung VM, Shimodaira S, Lindsay KL, et al. Hepatitis C virus induces a mutator phenotype: enhanced mutations of immunoglobulin and protooncogenes. *Proc Natl Acad Sci USA* 2004;101:4262-7. (Abstract)
- Mason AL, Lau JY, Hoang N, et al. Association of diabetes mellitus and chronic hepatitis C virus infection. *Hepatology* 1999;29:328-33. (Abstract)
- Marazuela M, Garcia-Buey L, Gonzalez-Fernandez B, et al. Thyroid autoimmune disorders in patients with chronic hepatitis C before and during interferon- $\alpha$  therapy. *Clinical Endocrinology* 1996;44:635-42. (Abstract)
- Margin S, Craxi A, Fabiano C, et al. Hepatitis C viraemia in chronic liver disease: relationship to interferon  $\alpha$  or corticosteroid treatment. *Hepatology* 1994;19:273-9. (Abstract)
- Matsumori A, Yutani C, Ikeda Y, Kawai S, Sasayama S. Hepatitis C virus from the hearts of patients with myocarditis and cardiomyopathy. *Lab Invest* 2000;80:1137-42. (Abstract)

- Matsuo K, Kusano A, Sugumar A, Nakamura S, Tajima K, Mueller NE. Effect of hepatitis C virus infection on the risk of non-Hodgkin's lymphoma: a meta-analysis of epidemiological studies. *Cancer Sci* 2004;95:745-52. (Abstract)
- McGuire BM, Julian BA, Bynon JS Jr, Cook WJ, King SJ, Curtis JJ, et al. Brief communication: Glomerulonephritis in patients with hepatitis C cirrhosis undergoing liver transplantation. *Ann Intern Med* 2006;144:735-41. (Abstract)
- McHutchison JG, Dusheiko G, Shiffman ML, Rodriguez-Torres M, Sigal S, Bourliere M, et al. Eltrombopag for thrombocytopenia in patients with cirrhosis associated with hepatitis C. *N Engl J Med* 2007;357:2227-36. (Abstract)
- Mele A, Pulsoni A, Bianco E, Musto P, Szklo A, Sanpaolo MG, et al. Hepatitis C virus and B-cell non-Hodgkin lymphomas: an Italian multicenter case-control study. *Blood* 2003;102:996-9. (Abstract)
- Mehta SH, Brancati FL, Strathdee SA, Pankow JS, et al. Hepatitis C virus infection and incident type 2 diabetes. *Hepatology* 2003;38:50-6. (Abstract)
- Moucari R, Asselah T, Cazals-Hatem D, Voitot H, et al. Insulin resistance in chronic hepatitis C: Association with genotypes 1 and 4, serum HCV RNA level, and liver fibrosis. *Gastroenterology* 2008;134:416-23. (Abstract)
- Nagao Y, Sata M, Tanikawa K, Itoh K, Kameyama T. Lichen planus and hepatitis C virus in the northern Kyushu region of Japan. *Eur J Clin Invest* 1995;25:910-4. (Abstract)
- Nomura H, Tanimoto H, Kajiwara E, Shimono J, Maruyama T, Yamashita N, et al. Factors contributing to ribavirin-induced anemia. *J Gastroenterol Hepatol* 2004;19:1312-7. (Abstract)
- Paydas S., N. Seyrek, G. Gonlusen, Y. Sagliker. The frequencies of hepatitis B virus markers and hepatitis C virus antibody in patients with glomerulonephritis. *Nephron* 1996;74:617-9. (Abstract)
- Perry W, Hilsabeck RC, Hassanein TI. Cognitive dysfunction in chronic hepatitis C: a review. *Dig Dis Sci* 2008;53:307-21. (Abstract)
- Petrarca A, Rigacci L, Caini P, et al. Safety and efficacy of rituximab in patients with hepatitis C virus-related mixed cryoglobulinemia and severe liver disease. *Blood* 2010;116:335-42. (Abstract)
- Plöckinger U, Krüger D, Bergk A, Weich V, Wiedenmann B, Berg T. Hepatitis-C patients have a reduced growth hormone (GH) secretion which improves during long-term therapy with pegylated interferon- $\alpha$ . *Am J Gastroenterol* 2007;102:2724-31. (Abstract)
- Prummel MF, Laurberg P. Interferon-alpha and autoimmune thyroid disease. *Thyroid* 2003;13:547-51. (Abstract)
- Rajan SK, Espina BM, Liebman HA. Hepatitis C virus-related thrombocytopenia: clinical and laboratory characteristics compared with chronic immune thrombocytopenic purpura. *Br J Haematol* 2005;129:818-24. (Abstract)
- Ray RB, Meyer K, Ray R. Suppression of apoptotic cell death by hepatitis C virus core protein. *Virology* 1996;226:176-82. (Abstract)
- Roccatello D, Baldovino S, Rossi D, Mansouri M, Naretto C, et al. Long-term effects of anti-CD20 monoclonal antibody treatment of cryoglobulinaemic glomerulonephritis. *Nephrol Dial Transplant* 2004;19:3054-61. (Abstract)
- Roccatello D, Baldovino S, Rossi D, Giachino O, Mansouri M, et al. Rituximab as a Therapeutic Tool in Severe Mixed Cryoglobulinemia. *Clin Rev Allergy Immunol* 2008;34:111-7. (Abstract)
- Rollino C., D. Roccatello, O Giachino, B. Basolo, G. Piccoli. Hepatitis C virus Infection and membranous glomerulonephritis. *Nephron* 1991;59:319-20. (Abstract)
- Roque Afonso AM, Jiang J, Penin F, Tareau C, Samuel D, Petit MA, et al. Nonrandom distribution of hepatitis C virus quasispecies in plasma and peripheral blood mononuclear cell subsets. *J Virol* 1999;73:9213-21. (Abstract)
- Saadoun D, Asselah T, Resche-Rigon M, Bedossa P, Valla D, et al. Cryoglobulinemia is associated with steatosis and fibrosis in chronic hepatitis C. *Hepatology* 2006;43:1337-45. (Abstract)
- Saadoun D, Resche-Rigon M, Sene D, Perard L, Piette JC, Cacoub P. Rituximab combined with Peg-Interferon-Ribavirin in refractory HCV-associated cryoglobulinemia vasculitis. *Ann Rheum Dis* 2008;67:1431-36. (Abstract)
- Saadoun D, Rosenzweig M, Joly F, et al. Regulatory T-cell responses to low-dose interleukin-2 in HCV-induced vasculitis. *N Engl J Med* 2011;365:2067-77. (Abstract)



- Sabry AA, Sobh MA, Sheaashaa HA, Kudesia G, Wild G, Fox S, et al. Effect of combination therapy (ribavirin and interferon) in HCV-related glomerulopathy. *Nephrol Dial Transplant* 2002;17:1924-30. ([Abstract](#))
- Sakamuro D, Furukawa T, Takegami T. Hepatitis C virus nonstructural protein NS3 transforms NIH 3T3 cells. *J Virol* 1995;69:3893-6. ([Abstract](#))
- Sansonno D, Gesualdo L, Manno C, Schena FP, Dammacco F. Hepatitis C virus-related proteins in kidney tissue from hepatitis C virus-infected patients with cryoglobulinemic membranoproliferative glomerulonephritis. *Hepatology* 1997;25: 1237-44. ([Abstract](#))
- Sansonno D, De Re V, Lauletta G, Tucci FA, Boiocchi M, Dammacco F. Monoclonal antibody treatment of mixed cryoglobulinemia resistant to interferon alpha with an anti-CD20. *Blood* 2003;101:3818-26. ([Abstract](#))
- Silvestri F, Barillari G, Fanin R, Pipan C, Falasca E, Salmaso F, et al. Hepatitis C virus infection among cryoglobulinemic and non-cryoglobulinemic B-cell non-Hodgkin's lymphomas. *Haematologica* 1997;82:314-7. ([Abstract](#))
- Srinivasan R. Autoimmune hemolytic anemia in treatment na?ve chronic hepatitis C infection. *J Clin Gastroenterol* 2001;32:245-7. ([Abstract](#))
- Stölzel U, Köstler E, Koszka C, Stöffler-Meilicke M, Schuppan D, Somasundaram R, et al. Low prevalence of hepatitis C virus infection in porphyria cutanea tarda in Germany. *Hepatology* 1995;21:1500-3. ([Abstract](#))
- Takehara K, Otsuka T, Arai T, Matsuzaki Y, et al. Detection of hepatitis C virus (HCV) in platelets of type C chronic liver diseases by polymerase chain reaction (PCR). *Gastroenterology* 1994;106:A995.
- Tarantino A, Campise M, Banfi G, Confalonieri R, Bucci A, Montoli A, et al. Long-term predictors of survival in essential mixed cryoglobulinemic glomerulonephritis. *Kidney Int* 1995;47:618-23. ([Abstract](#))
- Tembl JJ, Ferrer JM, Sevilla MT, Lago A, Mayordomo F, Vilchez JJ. Neurologic complications associated with hepatitis C virus infection. *Neurology* 1999;19:889-95. ([Abstract](#))
- Ueda T, Ohta K, Suzuki N, Yamaguchi M, Hirai K, et al. Idiopathic pulmonary fibrosis and high prevalence of serum antibodies to hepatitis C virus. *Am Rev respire Dis* 1992;146:266-8. ([Abstract](#))
- Vallisa D, Bernuzzi P, Arcaini L, Sacchi S, Callea V, Marasca R, et al. Role of anti-hepatitis C virus (HCV) treatment in HCV-related, low-grade, B-cell, non-Hodgkin's lymphoma: a multicenter Italian experience. *J Clin Oncol* 2005;23:468-73. ([Abstract](#))
- van Leusen R, Adang RP, de Vries RA, Cnossen TT, Konings CJ, Schalm SW, Tan AC. Pegylated interferon alfa-2a (40 kD) and ribavirin in haemodialysis patients with chronic hepatitis C. *Nephrol Dial Transplant* 2008;23:721-5 ([Abstract](#))
- Vezali E, Elefsiniotis I, Mihas C, Konstantinou E, Saroglou G. Thyroid dysfunction in patients with chronic hepatitis C: Virus-or therapy-related? *J Gastroenterol Hepatol* 2009;24:1024-9. ([Abstract](#))
- Vigano M, Lampertico P, Rumi MG, Folli C, Maggioni L, et al. Natural history and clinical impact of cryoglobulins in chronic Hepatitis C: 10-year prospective study of 343 patients. *Gastroenterology* 2007;133:835-42. ([Abstract](#))
- Wang CS, Yao WJ, Wang ST, Chang TT, Chou P. Strong association of Hepatitis C virus (HCV) infection and thrombocytopenia: implications from a survey of a community with hyperendemic HCV infection. *Clin Infect Dis* 2004;39:790-6. ([Abstract](#))
- Weiner SM, Berg T, Berthold C, Weber S, Peters T, Blum H, et al. A clinical and virological study of hepatitis C virus-related cryoglobulinemia in Germany. *J Hepatol* 1998;29:375-84 ([Abstract](#))
- Weissenborn K, Ennen JC, Bokemeyer M, Ahl B, Wurster U, Tillmann H, et al. Monoaminergic neurotransmission is altered in hepatitis C virus infected patients with chronic fatigue and cognitive impairment. *Gut*. 2006;55:1624-30. ([Abstract](#))
- Weitz IC. Treatment of immune thrombocytopenia associated with interferon therapy of hepatitis C with the anti-CD20 monoclonal antibody, rituximab. *Am J Hematol* 2005;78:138-41. ([Abstract](#))
- White DL, Ratzliff V, El-Serag HB. Hepatitis C infection and risk of diabetes: A systematic review and meta-analysis. *J Hepatol* 2008;49:831-44. ([Abstract](#))
- Wintrobe M, Buell M. Hyperproteinemia associated with multiple myeloma. With report of a case in which extraordinary hyperproteinemia was associated with thrombosis of the retinal veins and symptoms suggesting Raynaud's disease. *Bull Johns Hopkins Hosp* 1933;52:156-65.

- Wong VS, Egner W, Elsey T, Brown D, Alexander GJ. Incidence, character and clinical relevance of mixed cryoglobulinaemia in patients with chronic hepatitis C virus infection. *Clin Exp Immunol* 1996;104:25-31. ([Abstract](#))
- Yamaguchi S, Kubo K, Fujimoto K, Hanaoka M, Hayasaka M, et al. Bronchoalveolar lavage fluid findings in patients with chronic hepatitis C before and after treatment with interferon alpha. *Thorax* 1997;52:33-7. ([Abstract](#))
- Zignego AL, Macchia D, Monti M, Thiers V, Mazzetti M, Foschi M, et al. Infection of peripheral mononuclear blood cells by hepatitis C virus. *J Hepatol* 1992;382-6. ([Abstract](#))
- Zignego AL, Giannelli F, Marrocchi ME, Mazzocca A, Ferri C, Giannini C, et al. T(14;18) translocation in chronic hepatitis C virus infection. *Hepatology* 2000;31:474-9. ([Abstract](#))
- Zignego AL, Ferri C, Pileri SA, Caini P, Bianchi FB. Extrahepatic manifestations of the Hepatitis C Virus infection: a general overview and guidelines for clinical approach. *Dig Liver Dis* 2007a;39:2-17 ([Abstract](#))
- Zignego AL, Giannini C, Ferri C. Hepatitis C virus-related lymphoproliferative disorders: an overview. *World J Gastroenterol* 2007b;13:2467-78. ([Abstract](#))
- Zignego AL, Cozzi A, Carpenedo R, Giannini C, Rosselli M, Biagioli T, et al. HCV patients, psychopathology and tryptophan metabolism: analysis of the effects of pegylated interferon plus ribavirin treatment. *Dig Liver Dis* 2007c;39:107-11. ([Abstract](#))

# 17. Management of HBV/HIV coinfection

*Stefan Mauss and Jürgen Kurt Rockstroh*

## Introduction

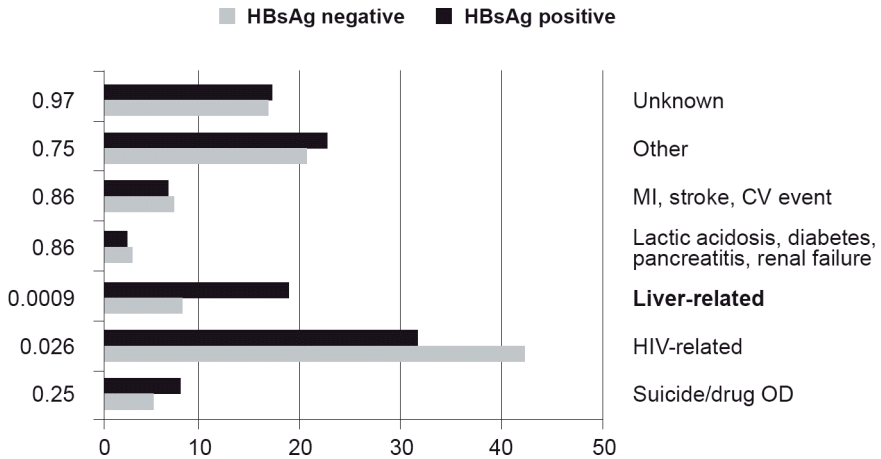
The prevalence and transmission routes of HBV coinfection in the HIV+ population vary substantially by geographic region (Alter 2006, Konopnicki 2005). In the United States and Europe the majority of HIV+ homosexual men have evidence of past HBV infection, and 5-10% show persistence of HBs antigen with or without replicative hepatitis B as defined by the presence of HBV DNA (Konopnicki 2005). Overall, rates of HBV/HIV coinfection are slightly lower among intravenous drug users compared to homosexual men and much lower among people infected through heterosexual contact (Núñez 2005).

In endemic regions of Africa and Asia, the majority of HBV infections are transmitted vertically at birth or before the age of 5 through close contact within households, medical procedures and traditional scarification (Modi 2007). The prevalence among youth in some Asian countries has substantially decreased since the introduction of vaccination on nationwide scales (Shepard 2006). In Europe vaccination of children and members of risk groups is reimbursed by health care systems in most countries.

The natural history of hepatitis B is altered by simultaneous infection with HIV. Immune control of HBV is negatively affected leading to a reduction of HBs antigen seroconversion. If HBV persists, the HBV DNA levels are generally higher in untreated patients (Bodsworth 1989, Bodsworth 1991, Hadler 1991). In addition, with progression of cellular immune deficiency, reactivation of HBV replication despite previous HBs antigen seroconversion may occur (Soriano 2005). In the untreated HIV-positive population, faster progression to liver cirrhosis is reported for HBV/HIV-coinfected patients (Puoti 2006). Moreover, hepatocellular carcinoma may develop at an earlier age and is more aggressive in this population (Puoti 2004, Brau 2007).

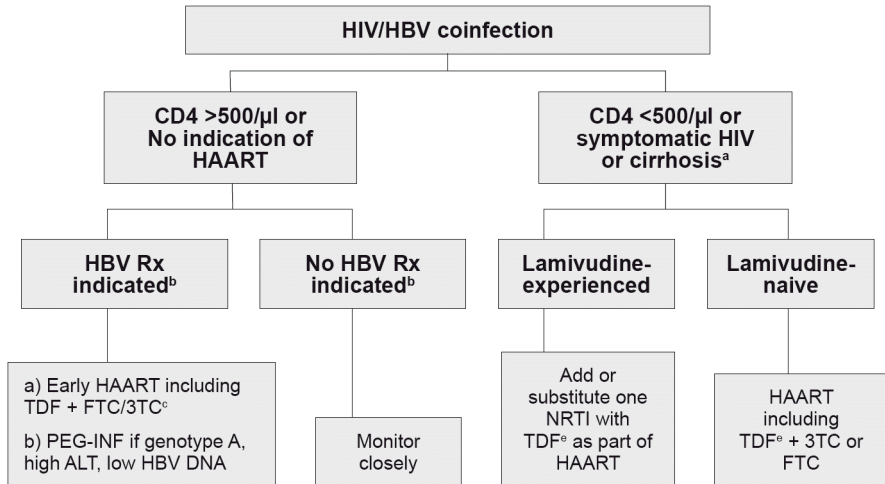
Being HBV-coinfected results in increased mortality for HIV-positive individuals, even after the introduction of highly active antiretroviral combination therapy (HAART), as demonstrated by an analysis of the EuroSIDA Study, which shows a 3.6-fold higher risk of liver-related deaths among HBsAg-positive patients compared to HBsAg-negative individuals (Konopnicki 2005, Nikolopoulos 2009) (Figure 1). In the Multicentre AIDS Cohort Study (MACS), an 8-fold increased risk of liver-related mortality was seen among HBV/HIV-coinfected compared to HIV-

monoinfected individuals, particularly among subjects with low nadir CD4-positive cell counts (Thio 2002). An independent observation from a large cohort confirming this association is the reduction in mortality for HBV/HIV-coinfected patients treated with lamivudine compared to untreated patients (Puoti 2007). This result is even more remarkable because lamivudine is one of the least effective HBV polymerase inhibitors due to a rather rapid development of resistance. In general, due to its limited long-term efficacy, lamivudine monotherapy for HBV cannot be considered as appropriate therapy (Matthews 2011).



**Figure 1. Association of HBV/HIV coinfection and mortality (Konopnicki 2005).** More than one cause of death allowed per patient; p-values from chi-squared tests.

These two large cohort studies (EuroSIDA and MACS) plus data from HBV monoinfection studies showing a reduction in morbidity and mortality justify treatment of hepatitis B in HBV/HIV-coinfected patients. HBV is often treated simultaneously with HIV, as some nucleoside and nucleotide reverse transcriptase inhibitors are active as HBV polymerase inhibitors as well. Therefore, antiretroviral therapy should be adjusted according to HBV status wherever possible to avoid higher pill burden and additional toxicities. A less frequent but more challenging situation is the initiation of HBV therapy in HIV-coinfected individuals who are not on antiretroviral therapy. Treatment with interferon is one possible therapeutic option in this situation. The main limitation of some HBV polymerase inhibitors may be induction of HIV resistance by the anti-HBV agents as they act simultaneously as HIV reverse transcriptase inhibitors.



**Figure 2. Treatment algorithm for therapy of HBV in HIV-coinfected patients (EACS 2011).**

a) Cirrhotic patients should be referred for variceal assessment, have regular HCC monitoring and be referred early for transplant assessment.

b) See Figure 5 for assessment of HBV Rx indication. Some experts strongly think that any HBV-infected patient requiring HAART should receive TDF + 3TC or FTC unless history of TDF intolerance, particularly in HIV/HBV coinfecting patients with advanced liver fibrosis (F3/F4).

c) If patient is unwilling to go on early HAART, adefovir and telbivudine may be used as an alternative to control HBV alone. Recently a case report suggested anti-HIV activity of telbivudine. *In vitro* data using an assay able to demonstrate anti-HIV activity of entecavir failed to detect an influence of telbivudine on the replicative capacity of HIV-1. Treatment duration: in patients not requiring HAART and on treatment with telbivudine +/- adefovir, or those on HAART where nucleoside backbone needs changing, anti-HBV therapy may be stopped cautiously in HBeAg+ patients who have achieved HBe seroconversion or HBs seroconversion for at least six months or, after HBs seroconversion; for at least six months in those who are HBeAg-.

d) Treatment length: 48 weeks for PEG-INF; on-treatment quantification of HBsAg in patients with HBeAg-negative chronic hepatitis B treated with PEG-INF may help identify those likely to reach HBs-antigen seroconversion with this therapy and optimize treatment strategies.

e) In some cases of tenofovir intolerance (i.e., renal disease), entecavir or tenofovir in doses adjusted to renal clearance in combination with effective HAART may be advisable. NRTI substitution should only be performed if feasible and appropriate from the perspective of maintaining HIV suppression. Caution is warranted in switching from a tenofovir-based regimen to drugs with a lower genetic barrier, e.g., FTC/3TC, in particular in lamivudine-pretreated cirrhotic patients, as viral breakthrough due to archived YMDD mutations has been observed. This has also been described in individuals with previous 3TC HBV resistance who have been switched from tenofovir to entecavir.

## HBV therapy in HBV/HIV-coinfected patients without HIV therapy

The recommendations of the updated European AIDS Clinical Society (EACS) for the treatment of chronic hepatitis B in HIV-coinfected patients without antiretroviral therapy are shown in Figure 2 (EACS 2011). Starting hepatitis B therapy depends on the degree of liver fibrosis and the HBV DNA level. Using the level of HBV

replication as the basis for treatment decisions is an important change of paradigm in HBV therapy. This decision is based on the results of the REVEAL study (Iloeje 2006). REVEAL followed the natural course of chronic hepatitis B without liver cirrhosis in about 3700 Taiwanese patients for more than 10 years. In these HBV-monoinfected patients an HBV DNA of >10,000 copies/ml (i.e., 2000 IU/ml) had a markedly increased risk of developing liver cirrhosis and hepatocellular carcinoma (Figure 3). This association was even observed in patients with normal ALT levels (Chen 2006) (Figure 4).

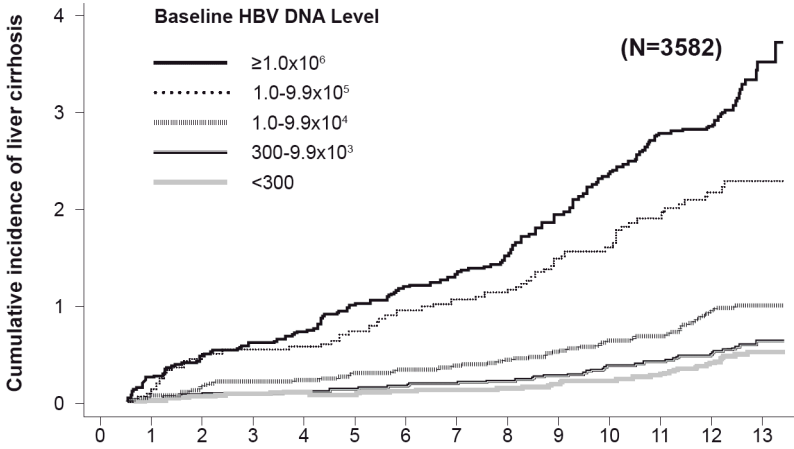


Figure 3. REVEAL Study: Association of HBV DNA levels and liver cirrhosis (Iloeje 2006).

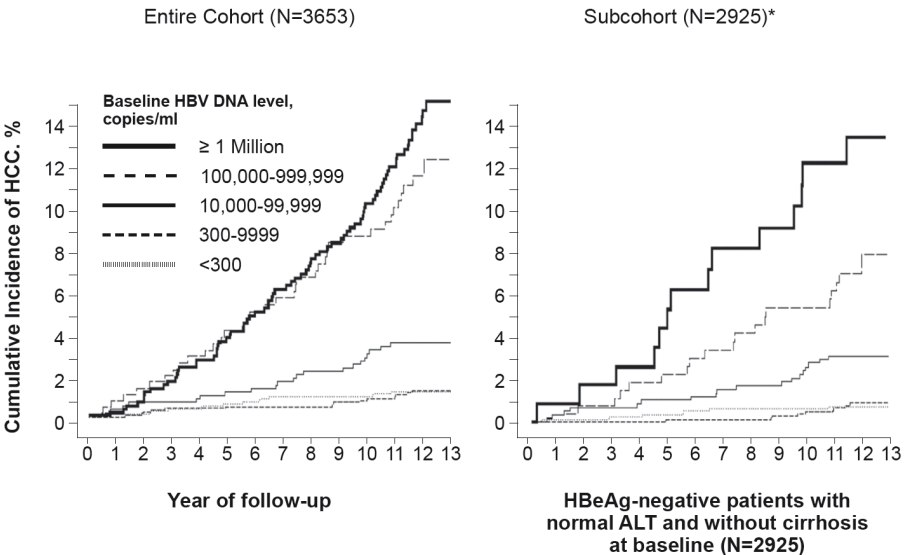


Figure 4. REVEAL Study: Association of HBV DNA with the development of hepatocellular carcinoma (Chen 2006).

It should be mentioned that this cohort consisted of Asian patients without HIV coinfection predominantly infected at birth or in early childhood. However, the results were considered too important not to form part of the management of HIV-coinfected patients.

Usually patients with an HBV DNA of less than 2000 IU/ml have no substantial necroinflammatory activity in the liver and therefore a benign course of fibrosis progression and a low risk for the development of hepatocellular carcinoma. However, especially in patients harbouring HBV precore mutants, fluctuations in HBV DNA and ALT are not rare. Monitoring of the activity of the HBV DNA and ALT accompanied by an abdominal ultrasound every 6-12 months is recommended. In the case of HBV DNA <2000 IU/ml and elevated transaminases and/or signs of advanced liver fibrosis, alternative causes of hepatitis and liver toxicity should be excluded.

For patients with HBV DNA >2000 IU/ml the ALT level is the next decision criterion. Patients with normal ALT should be assessed for liver fibrosis by liver biopsy or elastometry. In case of lack of substantial liver fibrosis (METAVIR stage F0/1) monitoring of the activity of the HBV DNA and ALT accompanied by an ultrasound every 3-6 months is recommended. In the presence of liver fibrosis of METAVIR F2 or higher, hepatitis B treatment should be initiated.

For patients with HBV DNA >2000 IU/ml and increased ALT, treatment for HBV is an option particularly in the presence of relevant liver fibrosis.

In patients not taking antiretroviral therapy, pegylated interferon  $\alpha$ -2a or -2b seems a suitable option. However, data in the literature for HIV-coinfected patients on interferon therapy for HBV infection are limited and not very encouraging (Núñez 2003). For pegylated interferons no data from larger cohorts exist and one study combining pegylated interferon with adefovir did not show encouraging results (Ingiliz 2008). Favourable factors for treatment success with interferon are low HBV DNA, increased ALT, HBV genotype A or infection with HBV wild type.

Alternatively patients can be treated with polymerase inhibitors. However, due to their antiretroviral activity tenofovir, emtricitabine and lamivudine are contraindicated in the absence of effective HIV therapy. In contrast to *in vitro* data reported by the manufacturer, antiretroviral activity and induction of the HIV reverse transcriptase mutation M184V was reported for entecavir (MacMahon 2007). Currently only telbivudine and adefovir are considered reasonably safe treatment options. There is limited *in vivo* data for adefovir to support this recommendation (Delaugerre 2002; Sheldon 2005). For telbivudine *in vitro* data are available showing a specific inhibitory activity on the HBV polymerase and no effect on HIV (Avilla 2009). However, in contrast with this, two case reports have suggested antiretroviral activity of telbivudine (Low 2009, Milazzo 2009).

Because of its greater antiviral efficacy, telbivudine is preferred by most experts to adefovir (Chan 2007). Alternatively an add-on strategy of telbivudine to adefovir in the case of not fully suppressive antiviral therapy or primary combination therapy of both drugs can be considered although clinical data are not yet available for this strategy.

As both drugs have limitations in the setting of HBV-monoinfected patients due to considerable development of resistance to telbivudine and the limited antiviral efficacy of adefovir, the initiation of antiretroviral therapy using tenofovir plus

lamivudine or emtricitabine should be considered, particularly in HIV-coinfected patients with advanced liver fibrosis.

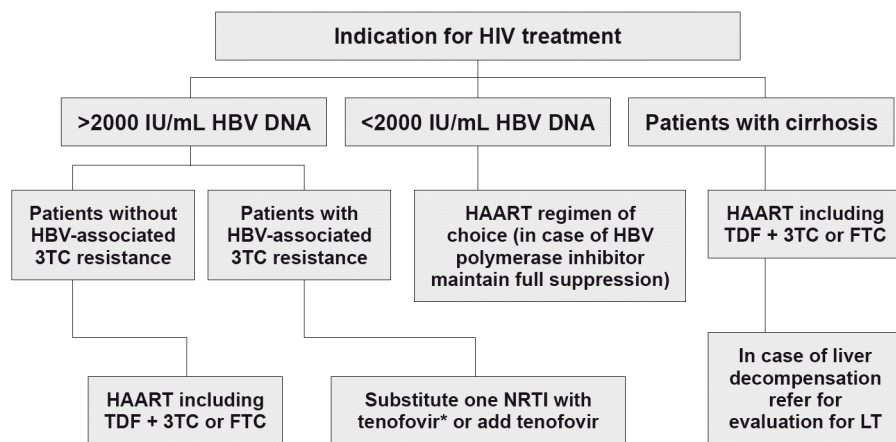
The treatment duration is determined by HBe antigen or HBs antigen seroconversion, like with HBV-monoinfected patients. In case of infection with a precore mutant HBs antigen seroconversion is the biological endpoint.

## Treatment of chronic hepatitis B in HBV/HIV-coinfected patients

For patients on antiretroviral therapy a wider choice of polymerase inhibitors is available. In principle, the treatment algorithm of Figure 5 is based on the same principles as outlined above (EACS 2011).

Initiating antiretroviral therapy with tenofovir resulted in higher rates of HBe antigen loss and seroconversion as expected from HBV-monoinfected patients (Schmutz 2006, Piroth 2010). This may be due to the additional effect of immune reconstitution in HIV-coinfected patients adding another aspect to the immunological control of HBV replication.

For patients with HBV DNA <2000 IU/ml and no relevant liver fibrosis no specific antiretroviral regimen is recommended. However when choosing an HBV polymerase inhibitor, the complete suppression of HBV DNA is important to avoid the development of HBV resistance mutations. The activity of the HBV infection in these patients should be assessed at least every six months as part of routine monitoring of the HIV infection including an ultrasound due to the slightly increased risk of hepatocellular carcinoma.



**Figure 5. Treatment algorithm for HBV therapy in patients with antiretroviral therapy (EACS 2011).**

When HBV DNA is above 2000 IU/ml in naïve patients a combination of tenofovir plus lamivudine/emtricitabine to treat both infections is recommended. Even for patients who harbour lamivudine-resistant HBV due to previous therapies



this strategy stands. The recommendation to continue lamivudine/emtricitabine is based on the delay of resistance to adefovir seen when doing so (Lampertico 2007).

For patients with liver cirrhosis a maximally active continuous HBV polymerase inhibitor therapy is important to avoid hepatic decompensation and reduce the risk of developing hepatocellular carcinoma. Tenofovir plus lamivudine/emtricitabine is the treatment of choice. If the results are not fully suppressive, adding entecavir should be considered (Ratcliffe 2011). At least every six months, assessment of the liver by ultrasound for early detection of hepatocellular carcinoma is necessary. In patients with advanced cirrhosis gastroscopy should be performed as screening for esophageal varices.

For patients with hepatic decompensation and full treatment options for HBV and stable HIV infection, liver transplantation should be considered, as life expectancy seems to be the same as for HBV-monoinfected patients (Coffin 2007, Tateo 2009). Patients with hepatocellular carcinoma may be considered liver transplant candidates as well, although according to preliminary observations from small cohorts, the outcome may be worse than for HBV-monoinfected patients with hepatocellular carcinoma (Vibert 2008).

In general, tenofovir can be considered the standard of care for HBV in HIV-coinfected patients, because of its efficacy and its strong HBV polymerase activity. Tenofovir has been a long-acting and effective therapy in the vast majority of treated HBV/HIV-coinfected patients (van Bömmel 2004, Mathews 2009, Martin-Carbonero 2011, Thibaut 2011). No conclusive pattern of resistance mutations has been identified in studies or cohorts (Snow-Lampart 2011). But resistance is likely to occur in patients with long-term therapy as with any other antiviral. In prospective controlled studies tenofovir was clearly superior to adefovir for treatment of HBe antigen-positive and HBe antigen-negative patients (Marcellin 2008).

The acquisition of adefovir resistance mutations and multiple lamivudine resistance mutations may impair the activity of tenofovir (Fung 2005, Lada 2008, van Bömmel 2010), although even in these situations tenofovir retains activity against HBV (Berg 2008, Petersen 2009).

In lamivudine-resistant HBV the antiviral efficacy of entecavir in HIV-coinfected patients is reduced, as it is in HBV monoinfection (Shermann 2008). Because of this and the property of tenofovir as an approved antiretroviral, tenofovir is the preferred choice in treatment-naïve HIV-coinfected patients who have an antiretroviral treatment indication. The use of entecavir, telbivudine

or adefovir as an add-on to tenofovir or other drugs in the case of not fully suppressive antiviral therapy has not been studied in HIV-coinfected patients so far. The decision to do so is made on a case-by-case basis.

It was a general belief originating from the history of antiretroviral therapy that combination therapy of tenofovir plus lamivudine/emtricitabine would be superior to tenofovir monotherapy, in particular in patients with highly replicative HBV infection. However, to date no conclusive studies supporting this are available (Schmutz 2006, Mathews 2008, Mathews 2009).

In the case of development of HIV resistance to tenofovir it is important to remember its HBV activity before switching to another regimen without antiviral activity against HBV. Discontinuation of the HBV polymerase inhibitor without

maintaining the antiviral pressure on HBV can lead to necroinflammatory flares that can result in acute liver decompensation in serious cases.

A matter of concern is the potentially nephrotoxic effect of tenofovir. In patients treated with tenofovir monotherapy nephrotoxicity is rarely observed (Heathcote 2011, Mauss 2011). However in HIV-infected patients treated with tenofovir as part of an antiretroviral combination therapy renal impairment has been frequently reported and may be associated in particular with the combined use of tenofovir and HIV protease inhibitors (Mauss 2005, Fux 2007, Goicoechea 2008). Regular monitoring of renal function in HBV/HIV-coinfected patients including estimated glomerular filtration rate and assessment of proteinuria is necessary.

## Management of resistance to HBV polymerase inhibitors

Issues concerning the avoidance and management of resistance to HBV polymerase inhibitors are discussed in detail in Chapter 10.

## Conclusion

The number of available HBV polymerase inhibitors for chronic hepatitis B has increased substantially over the last few years. In general though, the choice is confined to two mostly non-cross-resistant classes, the nucleotide and nucleoside compounds. In HIV-coinfected patients where antiretroviral therapy is not indicated the choice is more limited with only adefovir and telbivudine as treatment options. Alternative options in these patients may be interferon therapy or the initiation of full antiretroviral therapy, which is currently preferred by most experts, although both toxicities and costs may increase.

For HBV/HIV-coinfected patients on antiretroviral therapy the treatment of choice is tenofovir in the majority of treatment-naïve or lamivudine-pretreated cases. Due to rapid development of resistance in not fully suppressive HBV therapy lamivudine or emtricitabine monotherapy should not be considered in the vast majority of cases. A combination of tenofovir plus lamivudine or emtricitabine as a primary combination therapy has theoretical advantages, but studies supporting this concept have not been published to date.

In general, treatment of HBV as a viral disease follows the same rules as HIV therapy, aiming at a full suppression of the replication of the virus to avoid the development of resistance. Successful viral suppression of hepatitis B results in inhibition of necroinflammatory activity, reversion of fibrosis and the ultimate goal of immune control of the infection.

## References

- Alter M. Epidemiology of viral hepatitis and HIV co-infection. *J Hepatol* 2006; 44:6-9. ([Abstract](#))
- Lin K, Karwowska S, Lam E, Limoli K, Evans TG, Avila C. Telbivudine exhibits no inhibitory activity against HIV-1 clinical isolates in vitro. *Antimicrob Agents Chemother* 2010;54:2670-3. ([Abstract](#))
- Berg T, Marcellin P, Zoulim F, et al. Tenofovir is effective alone or with emtricitabine in adefovir-treated patients with chronic-hepatitis B virus infection. *Gastroenterology* 2010;139:1207-17. ([Abstract](#))

- Bodsworth N, Donovan B, Nightingale BN. The effect of concurrent human immunodeficiency virus infection on chronic hepatitis B: a study of 150 homosexual men. *J Infect Dis* 1989;160:577-82. ([Abstract](#))
- Bodsworth NJ, Cooper DA, Donovan B. The influence of human immunodeficiency virus type 1 infection on the development of the hepatitis B virus carrier state. *J Infect Dis* 1991;163:1138-40. ([Abstract](#))
- Brau N, Fox R, Xiao P, et al. Presentation and outcome of hepatocellular carcinoma in HIV-infected patients: A US-Canadian multicenter study. *J Hepatol* 2007;47:527-37. ([Abstract](#))
- Chan HL, Heathcote EJ, Marcellin P, et al. Treatment of Hepatitis B e Antigen-Positive Chronic Hepatitis with Telbivudine or Adefovir: A Randomized Trial. *Ann Intern Med* 2007;147:2-11. ([Abstract](#))
- Chen CJ, Yang HI, Su J, Jen CL, et al. REVEAL-HBV Study Group. Risk of hepatocellular carcinoma across a biological gradient of serum hepatitis B virus DNA level. *JAMA* 2006;4:295:65-73. ([Abstract](#))
- Coffin CS, Stock PG, Dove LM, et al. Virologic and clinical outcomes of hepatitis B virus infection in HIV-HBV coinfecting transplant recipients. *Am J Transplant* 2010;10:1268-75. ([Abstract](#))
- Delaugerre C, Marcelin AG, Thibault V, et al. Human immunodeficiency virus (HIV) Type 1 reverse transcriptase resistance mutations in hepatitis B virus (HBV)-HIV-coinfecting patients treated for HBV chronic infection once daily with 10 milligrams of adefovir dipivoxil combined with lamivudine. *Antimicrob Agents Chemother* 2002;46:1586-8. ([Abstract](#))
- EACS guidelines 2011.  
[http://www.europeanaidscinicalsociety.org/index.php?option=com\\_content&view=article&id=59&Itemid=41](http://www.europeanaidscinicalsociety.org/index.php?option=com_content&view=article&id=59&Itemid=41) ([Abstract](#))
- Fung SK, Andreone P, Han SH, et al. Adefovir-resistant hepatitis B can be associated with viral rebound and hepatic decompensation. *J Hepatol* 2005;43:937-43. ([Abstract](#))
- Fux CA, Simcock M, Wolbers M, et al. Swiss HIV Cohort Study. Tenofovir use is associated with a reduction in calculated glomerular filtration rates in the Swiss HIV Cohort Study. *Antivir Ther* 2007;12:1165-73. ([Abstract](#))
- Goicoechea M, Liu S, Best B, et al. California Collaborative Treatment Group 578 Team. Greater tenofovir-associated renal function decline with protease inhibitor-based versus nonnucleoside reverse-transcriptase inhibitor-based therapy. *J Infect Dis* 2008;197:102-8. ([Abstract](#))
- Hadler SC, Judson FN, O'Malley PM, et al. Outcome of hepatitis B virus infection in homosexual men and its relation to prior human immunodeficiency virus infection. *J Infect Dis* 1991;163:454-9. ([Abstract](#))
- Heathcote EJ, Marcellin P, Buti M, et al. Three-year efficacy and safety of tenofovir disoproxil fumarate treatment for chronic hepatitis B. *Gastroenterology* 2011;140:132-43. ([Abstract](#))
- Iloeje UH, Yang HI, Su J, Jen CL, You SL, Chen CJ. Risk Evaluation of Viral Load Elevation and Associated Liver Disease/Cancer-In HBV (the REVEAL-HBV) Study Group. Predicting cirrhosis risk based on the level of circulating hepatitis B viral load. *Gastroenterology* 2006;130:678-86. ([Abstract](#))
- Ingiliz P, Valantin MA, Thibault V, et al. Efficacy and safety of adefovir dipivoxil plus pegylated interferon-alpha2a for the treatment of lamivudine-resistant hepatitis B virus infection in HIV-infected patients. *Antivir Ther* 2008;13:895-900. ([Abstract](#))
- Konopnicki D, Mocroft A, de Wit S, et al. Hepatitis B and HIV: prevalence, AIDS progression, response to highly active antiretroviral therapy and increased mortality in the EuroSIDA cohort. *AIDS* 2005;19:593-601. ([Abstract](#))
- Lada O, Gervais A, Branger M, et al. Long-term outcome of primary non-responders to tenofovir therapy in HIV/HBV-co-infected patients: impact of HBV genotype G. *Liver Int* 2012;32:93-101. ([Abstract](#))
- Lampertico P, Viganò M, Manenti E, Iavarone M, Sablon E, Colombo M. Low resistance to adefovir combined with Lamivudine: a 3-year study of 145 Lamivudine-resistant hepatitis B patients. *Gastroenterology* 2007;133:1445-51. ([Abstract](#))
- Low E, Cox A, Atkins M and Nelson M. Telbivudine Has Activity against HIV. Proceedings of the 12th Conference on Retroviruses and Opportunistic Infections; Montréal, Canada; 2009 February 8-11; poster 813a

- Marcellin P, Heathcote EJ, Buti M, et al. Tenofovir disoproxil fumarate versus adefovir dipivoxil for chronic hepatitis B. *N Engl J, et al. Clinical and virological outcomes in HIV-infected patients with chronic hepatitis B on long-term nucleos(t)ide analogues. AIDS* 2011;25:73-9.
- Matthews GV, Avihingsanon A, Lewin SR, et al. A randomized trial of combination hepatitis B therapy in HIV/HBV coinfecting individuals in Thailand. *Hepatology* 2008;48:1062-9. ([Abstract](#))
- Matthews GV, Seaberg E, Dore GJ, Bowden S, Lewin SR, Sasadeusz J, et al. Combination HBV therapy is linked to greater HBV DNA suppression in a cohort of lamivudine-experienced HIV/HBV coinfecting individuals. *AIDS* 2009;23:1707-15. ([Abstract](#))
- Matthews GV, Manzini P, Hu Z, et al. Impact of lamivudine on HIV and hepatitis B virus-related outcomes in HIV/hepatitis B virus individuals in a randomized clinical trial of antiretroviral therapy in southern Africa. *AIDS* 2011;25:1727-35. ([Abstract](#))
- Mauss S, Berger F, Schmutz G. Antiretroviral therapy with tenofovir is associated with mild renal dysfunction. *AIDS* 2005;19:93-5. ([Abstract](#))
- Mauss S, Berger F, Filmann N, et al. Effect of HBV polymerase inhibitors on renal function in patients with chronic hepatitis B. *J Hepatol* 2011;55:1235-40. ([Abstract](#))
- McMahon MA, Jilek BL, Brennan TP, et al. The HBV drug entecavir - effects on HIV-1 replication and resistance. *N Engl J Med* 2007;356:2614-21. ([Abstract](#))
- Milazzo L, Caramma I, Lai A, et al. Telbivudine in the treatment of chronic hepatitis B: experience in HIV type-1-infected patients naive for antiretroviral therapy. *Antivir Ther* 2009;14:869-72. ([Abstract](#))
- Modi A, Feld J. Viral hepatitis and HIV in Africa. *AIDS Rev* 2007;9:25-39. ([Abstract](#))
- Núñez M, Puoti M, Camino N, Soriano V. Treatment of chronic hepatitis B in the human immunodeficiency virus-infected patient: present and future. *Clin Infect Dis* 2003;37:1678-85. ([Abstract](#))
- Nikolopoulos GK, Paraskevis D, Hatzitheodorou E, et al. Impact of hepatitis B virus infection on the progression of AIDS and mortality in HIV-infected individuals: a cohort study and meta-analysis. *Clin Infect Dis* 2009;48:1763-71. ([Abstract](#))
- Núñez M, Soriano V. Management of patients co-infected with hepatitis B virus and HIV. *Lancet Infect Dis* 2005;5:374-82. ([Abstract](#))
- Petersen J, Ratziu V, Buti M, et al. Entecavir plus tenofovir combination as rescue therapy in pre-treated chronic hepatitis B patients: An international multicenter cohort study. *J Hepatol* 2011. [Epub ahead of print] ([Abstract](#))
- Piroth L, Pol S, Lacombe K, Miallhes P, et al. Management and treatment of chronic hepatitis B virus infection in HIV positive and negative patients: the EPIB 2008 study. *J Hepatol* 2010;53:1006-12. ([Abstract](#))
- Puoti M, Bruno R, Soriano V, et al. Hepatocellular carcinoma in HIV-infected patients: epidemiological features, clinical presentation and outcome. *AIDS* 2004;18:2285-93. ([Abstract](#))
- Puoti M, Cozzi-Lepri A, Arici C, et al. Impact of lamivudine on the risk of liver-related death in 2,041 HBsAg- and HIV-positive individuals: results from an inter-cohort analysis. *Antivir Ther* 2006;11:567-74. ([Abstract](#))
- Puoti M, Torti C, Bruno R. Natural history of chronic hepatitis B in co-infected patients. *J Hepatol* 2006;44:65-70. ([Abstract](#))
- Ratcliffe L, Beadsworth MB, Pennell A, Phillips M, Vilar FJ. Managing hepatitis B/HIV co-infected: adding entecavir to truvada (tenofovir disoproxil/emtricitabine) experienced patients. *AIDS* 2011;25:1051-6. ([Abstract](#))
- Schmutz G, Nelson M, Lutz T, et al. Combination of tenofovir and lamivudine versus tenofovir after lamivudine failure for therapy of hepatitis B in HIV-coinfection. *AIDS* 2006;20:1951-4.
- Sheldon JA, Corral A, Rodés B, et al. Risk of selecting K65R in antiretroviral-naive HIV-infected individuals with chronic hepatitis B treated with adefovir. *AIDS* 2005;19:2036-8. ([Abstract](#))
- Shepard CW, Simard EP, Finelli L, Fiore AE, Bell BP. Hepatitis B virus infection: epidemiology and vaccination. *Epidemiol, et al. Entecavir therapy for lamivudine-refractory chronic hepatitis B: improved virologic, biochemical, and serology outcomes through 96 weeks. Hepatology* 2008;48:99-108. ([Abstract](#))
- Snow-Lampart A, Chappell B, Curtis M, et al. No resistance to tenofovir disoproxil fumarate detected after up to 144 weeks of therapy in patients mono-infected with chronic hepatitis B virus. *Hepatology* 2011;53:763-73.

- Soriano V, Puoti M, Bonacini M. Care of patients with chronic hepatitis B and HIV co-infection: recommendations from an HIV-HBV international panel. *AIDS* 2005;19:221-240.
- Soriano V, Mocroft A, Peters L, et al. Predictors of hepatitis B virus genotype and viraemia in HIV-infected patients with chronic hepatitis B in Europe. *J Antimicrob Chemother* 2010;65:548-55. ([Abstract](#))
- Tateo M, Roque-Afonso AM, Antonini TM, et al. Long-term follow-up of liver transplanted HIV/hepatitis B virus coinfecting patients: perfect control of hepatitis B virus replication and absence of mitochondrial toxicity. *AIDS* 2009;23:1069-76. ([Abstract](#))
- Thibault V, Stitou H, Desire N, Valantin MA, Tubiana R, Katlama C. Six-year follow-up of hepatitis B surface antigen concentrations in tenofovir disoproxil fumarate treated HIV-HBV-coinfecting patients. *Antivir Ther* 2011;16:199-205. ([Abstract](#))
- Thio C, Seaberg E, Skolasky R. HIV-1, hepatitis B virus, and risk of liver-related mortality in the Multicenter AIDS Cohort Study (MACS). *Lancet* 2002;360:1921-6. ([Abstract](#))
- Van Bömmel F, Wünsche T, Mauss S, et al. Comparison of adefovir and tenofovir in the treatment of lamivudine-resistant hepatitis B virus infection. *Hepatology* 2004;40:1421-5. ([Abstract](#))
- Van Bömmel F, de Man RA, Wedemeyer H, et al. Long-term efficacy of tenofovir monotherapy for hepatitis B virus-monoinfected patients after failure of nucleoside/nucleotide analogues. *Hepatology* 2010;51:73-80. ([Abstract](#))

## 18. Management of HCV/HIV Coinfection

*Christoph Boesecke, Stefan Mauss, Jürgen Kurt Rockstroh*

### **Epidemiology of HIV and HCV coinfection**

HIV and HCV share transmission pathways, which explains the high rate of coinfection with both viruses. Of the 33.3 million HIV-infected persons worldwide in 2009 it is estimated that at least 5 million of them had concomitant hepatitis C virus infection. While both viruses are transmitted with high efficacy via blood-to-blood contact, HCV is less easily transmitted sexually. Thus, the prevalence of hepatitis C coinfection within different countries, regions and populations is closely related to the prevalence of blood-borne transmission (mainly intravenous drug use) of HIV. Among HIV-infected patients in Europe, Australia and the US, at least one out of four is coinfecting with hepatitis C (Rockstroh 2004). Hepatitis C coinfection rates as high as 70% can be found in Eastern European countries like Belarus and the Ukraine and in Middle Eastern countries such as Iran where intravenous drug use (IVDU) is the main route of HIV transmission (SeyedAlinaghi 2011). On the other hand, in Central European countries such as Belgium, Austria or Germany, where sexual intercourse dominates as mode of HIV transmission, hepatitis C coinfection rates are rather low, between 10 and 15% (Rockstroh 2005, CDC 2011). Similar rates can be found in HIV-positive patients in Australia (Jin 2009) and the UK (Turner 2009). Interestingly, recent data from the US indicate that 25% to 35% of patients with HIV are coinfecting with HCV (Singal 2009, CDC 2011) reflecting the contribution of at-risk populations such as prison inmates to the overall numbers. 65-70% of HIV-positive prisoners in the US are coinfecting with hepatitis C, in contrast to 18-25% of the general US HIV-positive population (Weinbaum 2005, CDC 2011). In Asia, coinfection rates of up to 85% have been observed among Chinese plasma donors whereas in countries with predominantly heterosexual HIV transmission like Thailand coinfection rates are around 10% (Qian 2006). In sub-Saharan Africa, where again the primary route of transmission of HIV is sexual, HCV coinfection rates so far have been reported to be relatively low.

Although the traditional route of HCV transmission is blood-borne and includes IVDU, snorting drugs, sharing toothbrushes/razors, and tattooing (Bollepalli 2007), recent epidemic outbreaks among HIV-positive men who have sex with men (MSM) from several major European cities such as London, Paris, Amsterdam, and Berlin as well as more recent reports from the US, Canada Australia and Taiwan

document that HCV may well be sexually transmitted and should therefore also be taken into account at regular STD screenings (Gotz 2005, Danta 2007, Vogel 2009, Vogel 2010, Matthews 2011, Schmidt 2011).

HCV is detected in 4-8% of infants born to HCV-infected mothers (Bevilacqua 2009). Dual HCV/HIV infection increases the risk for transmission of both viruses and high levels of HCV viremia in the mother increases the risk of perinatal HCV transmission (Zanetti 1995). However, in HIV/HCV-coinfected mothers receiving HAART and undergoing cesarean section the risk of HCV transmission is strikingly reduced to less than 1%.

In summary, the prevalence of hepatitis C within the HIV-infected population is far higher than in the general population where the global burden of hepatitis C is estimated to be roughly 2%. This highlights the importance of preventing further spread of hepatitis C infection as one of the major co-morbidities in HIV-infected individuals. The average estimated risk of transmission for hepatitis C in HIV is depicted in Table 1. Although they share common routes of infection, the viruses are transmitted with varying efficacy depending upon the mode of transmission.

**Table 1. Average estimated risk of transmission for HIV, HCV and HCV/HIV coinfection.**

Mode of transmission	HIV	HCV	HCV / HIV coinfection
Perinatal	7-50%	1-7%	1-20%
Sexual contact*	1-3%	<1%	<4%
Needle stick injury	0.3%	<1%	Unknown

\* On sexual contact the sexual risk refers to cumulative exposure

## Diagnosis of HCV in HIV coinfection

The presence of HCV can be confirmed serologically by the detection of antibodies to the virus via ELISA testing. Loss of HCV antibodies observed in rare cases in very advanced immune deficiency in HIV/HCV coinfection does not necessarily indicate viral clearance (Criber 1999). Therefore, a single negative HCV antibody ELISA does not necessarily exclude HCV infection in HIV-positive patients, especially in severe immune deficiency. Additionally, a rise of liver transaminases has been proven to be more sensitive in the detection of acute HCV infection in HIV-positive patients than repeated testing for the presence of antibodies against HCV (Thomson 2009). However, in more than 80% of HIV-positive individuals with positive HCV antibodies, HCV RNA is detected in the blood. Higher concentrations of HCV RNA are found in HIV-positive individuals than in HIV-negative patients with hepatitis C (Perez-Olmeda 2002). Interestingly, recent data from a cross-trial comparison showed that HIV-positive patients were less likely to present with elevated serum ALT and clinical signs or symptoms of hepatitis than HIV-negative patients (Vogel 2009). In observations from hemophiliac patients, mean HCV RNA concentrations increased by 1 log<sub>10</sub> over the first two years after HIV seroconversion (Eyster 1994). Levels of HCV viremia increase eight times faster in HIV-positive individuals than in HIV-negative patients with hepatitis C. The highest concentrations for HCV viremia have been reported in patients who subsequently developed liver failure.

Interestingly, spontaneous clearance of HCV RNA has been observed in some HIV/HCV-coinfected patients experiencing significant immune reconstitution following HAART initiation (Fialaire 1999, Thomson 2009). In contrast, there are also patients with positive HCV antibodies and negative HCV RNA in which HCV RNA was noted to re-emerge frequently in combination with a flare of liver transaminases after initiation of HAART. Therefore, regular monitoring of HCV RNA levels is warranted in HIV/HCV-coinfected patients.

The distribution of HCV genotypes in HIV-positive patients reflects the route of transmission. Genotype 1b accounts for 2/3 of post-transfusion HCV infections and is the predominant genotype in hemophiliacs. In contrast, genotypes 1a and 3a are more common in intravenous drug users (Pol 1994, Soriano 2008).

## Natural course of hepatitis C in HIV coinfection

Various studies have demonstrated that underlying HIV infection weakens the immune response to hepatitis C, thereby diminishing the chance of spontaneous viral clearance of HCV infection. Interestingly, data from the European epidemic of sexually transmitted acute hepatitis C infection in HIV-positive individuals suggest that despite underlying HIV infection spontaneous resolution of HCV may occur in up to 20-30% of newly infected patients (Vogel 2010, Thomson 2010). Recently, genome-wide association studies identified single nucleotide polymorphisms (SNP) near the IL28B gene encoding for interferon lambda that comprise a crucial part of the host's innate immune defence against HCV in HCV mono-infection (Thomas 2009). Individuals with the CC genotype were more than three times likely to clear HCV RNA and to better respond to standard HCV therapy compared with individuals with CT and TT genotypes (Rauch 2010, Grebely 2010, Nattermann 2011, Rallón 2011). Similar observations have been made in HIV/HCV coinfecting individuals (Clausen 2010). Interestingly, these SNPs could explain differences in spontaneous clearance rates between different ethnicities as the frequency of the protective allele varies across ethnic groups with a much lower frequency in those of African origin compared to Asian patients with Europeans being in-between (Thomas 2009).

Numerous large cohort studies have demonstrated that once chronic hepatitis C is established the presence of HIV leads to a faster HCV clinical progression due to the lack of critical CD4+ T cell responses against HCV (Danta 2008). In the American multicenter Hemophiliac Cohort Study liver failure occurred in 9% of multitransfused HCV/HIV-coinfected adult hemophiliacs without an AIDS-defining opportunistic infection or malignancy (Eyster 1993). In the same time period, no case of liver failure was observed in HCV-positive HIV-negative hemophiliacs. Subsequently, several studies have confirmed the unfavorable course of hepatitis C in HIV-coinfected hemophiliacs, particularly in the setting of progressive immunodeficiency and lower CD4 counts (Rockstroh 1996, Puoti 2000).

In addition, the time interval between HCV exposition and development of cirrhosis was found to be shortened in coinfecting subjects. Indeed, within 10-15 years of initial HCV infection, 15-25% of HIV-coinfected patients develop cirrhosis compared with 2-6% of HIV-negative patients (Soto 1997). Importantly, mortality due to advanced liver disease occurs ten years earlier in coinfecting hemophiliacs than in HIV-negative hemophiliacs with hepatitis C (Darby 1997). The incidence of



hepatocellular carcinoma seems also to be higher in coinfecting patients (Giordano 2004).

## Effect of hepatitis C on HIV infection

As clear as HIV's influence on the accelerated disease progression for HCV-associated liver disease is, HCV's influence on the course of HIV disease is conflicting. The Swiss Cohort first revealed a blunted CD4 cell response associated with a faster progression to AIDS after initiation of HAART in HIV/HCV-coinfecting patients (Greub 2000). Interestingly, four-year follow-up data from the same cohort study did not detect significant differences with regard to CD4 cell count recovery between HCV-positive and HCV-negative HIV-positive patients (Kaufmann 2003). Subsequent studies have indeed found that after adjusting for use of HAART, no difference in CD4 cell count recovery can be observed (Sulkowski 2002). Updated information from an analysis of the EuroSIDA cohort, after taking into account ongoing chronic (persistent HCV replication) and resolved (positive HCV antibodies but negative HCV RNA) hepatitis C infection, confirm that no difference in CD4 cell count recovery is observed in patients with chronic hepatitis C infection and detectable HCV RNA in comparison to HIV-monoinfecting patients (Rockstroh 2005). In addition, data from the same cohort revealed that CD4-positive T cell recovery in HIV-positive patients with maximal suppression of HIV replication is not influenced by HCV serostatus in general or HCV genotype or level of HCV in particular (Peters 2009).

## Effect of HAART on hepatitis C

In HIV/HCV-coinfecting patients starting antiretroviral therapy a transient increase in HCV RNA levels may occur at week 4 but thereafter no significant changes in concentrations of HCV RNA happen over the first six months of treatment (Rockstroh 1998). However, a  $1 \log_{10}$  decrease of HCV RNA has been reported in HIV/HCV-coinfecting individuals receiving more than 12 months of HAART and having significant immune reconstitution. Other investigators, however, have not observed this decrease in HCV RNA. Moreover, eradication of HCV has been reported in individual patients receiving HAART following CD4 count recovery.

There is increasing evidence that HAART-induced immune reconstitution might reverse the unfavorable accelerated course for hepatitis C in patients with severe HIV-associated immune deficiency (Verma 2006, Vogel 2009). Taking into account that liver disease progresses especially in those whose CD4 count drops below  $200/\mu\text{l}$  it is appealing to think that CD4 increases on HAART may impact the further course of liver disease. In an early study of 162 individuals with HIV/HCV coinfection who underwent liver biopsy, the use of protease inhibitors as part of their HAART regimen was associated with significantly lower rates of progression of liver fibrosis that could not be explained by other cofactors (Benhamou 2000). These findings were then confirmed by several cohort analyses which showed that HIV/HCV-coinfecting individuals on HAART had significantly lower liver-related mortality than patients receiving either suboptimal (one or two nucleoside reverse transcriptase inhibitors) or no antiretroviral therapy (Qurishi 2003).

One paper also addressed the amount of immune reconstitution achieved on HAART and the subsequent risk for developing hepatic decompensation in HIV/HCV-coinfected individuals commencing HAART (Pineda 2007). Those patients who experienced the highest CD4 cell count gain on HAART were the least likely to develop further complications of liver disease, again highlighting a favourable impact of HAART-induced immune reconstitution on the course of liver disease. As a consequence, the current antiretroviral treatment guidelines of the European AIDS Clinical Society recommend earlier initiation of antiretroviral therapy in HIV patients with HCV coinfection (CD4 T cell count between 350-500/ $\mu$ l in asymptomatic patients).

Short-term and long-term virologic success rates of HAART in HIV/HCV coinfection are, however, limited by an increased risk of hepatotoxicity. Various studies have shown that the presence of HCV is independently associated with an increased risk of rises in serum aminotransferases highlighting the need for close monitoring.

## Treatment of hepatitis C in HIV coinfection

The most important reason to treat hepatitis C in HIV-coinfected individuals is the unfavourable course of hepatitis C in the setting of HIV coinfection particularly with the increased life expectancy gained by successful HAART. An increased risk of hepatotoxicity after HAART initiation in HIV/HCV-coinfected patients, possibly limiting the long-term benefit of HAART in this particular group, further underlines the need for successful treatment of hepatitis C (Sulkowski 2000). Several studies have been able to demonstrate that successful treatment of hepatitis C dramatically reduces subsequent complications of preexisting liver disease. This implies that once viral clearance is achieved with hepatitis C combination therapy the prognosis of liver disease dramatically improves (even in the presence of already developed liver cirrhosis) and once HCV infection is eradicated further liver complications are very unlikely.

The goal of hepatitis C treatment is to achieve persistently negative HCV RNA levels. This is generally referred to as a sustained virologic response (SVR). It is defined as negative HCV RNA six months after completion of HCV therapy. Negative HCV RNA at the end of the treatment period is described as an end-of-treatment response (EOT). Negative HCV RNA after four weeks of HCV treatment initiation is referred to as rapid treatment response (RVR). Failure to respond to treatment is referred to as non-response.

The combination of pegylated interferon and ribavirin is still regarded as standard therapy in coinfecting patients. Table 2 summarizes the main results from randomized clinical trials investigating the efficacy of pegylated interferon and ribavirin in HIV/HCV-coinfected individuals. Data from the GESIDA study show similar efficacy and safety for both pegylated IFN  $\alpha$ -2b and pegylated IFN  $\alpha$ -2a in the treatment of chronic HCV infection in HIV-infected patients (Berenguer 2009).

Overall, SVR rates of up to 50% can be achieved (Torriani 2004; Nunez 2007). The difference in rates of SVR in various studies can be explained mainly by differences in ribavirin dosages used, fibrosis stage and probably variations in the IL28B genotype. In the initial HCV treatment trials in HIV-coinfected individuals, due to the fear of interactions between ribavirin and commonly used NRTIs for HIV

treatment, 800 mg daily dose of ribavirin was chosen for most patients independent of the prevailing genotype. This led to suboptimal SVR rates. However, in the PRESCO trial, where weight-adjusted daily ribavirin dosages of 1000-1200 mg were used independent of genotype, SVR rates almost doubled in comparison to some of the earlier studies such as APRICOT, most likely due to the higher ribavirin levels. In spite of this, data from the PARADIGM trial, a double-blind, multicenter study comparing 800 vs 1000/1200 mg of ribavirin plus PEG-IFN in HCV/HIV-coinfected patients showed no significant differences in the rates of SVR (Rodriguez-Torres 2009).

In the current guidelines, daily administration of ribavirin 1000 mg (<75 kg body weight) and 1200 mg (>75 kg body weight) BID is recommended for HCV therapy in HIV coinfection for all genotypes in combination with pegylated interferon.

**Table 2. Results from randomized clinical trials investigating the efficacy of pegylated interferon plus ribavirin in HIV/HCV-coinfected individuals.**

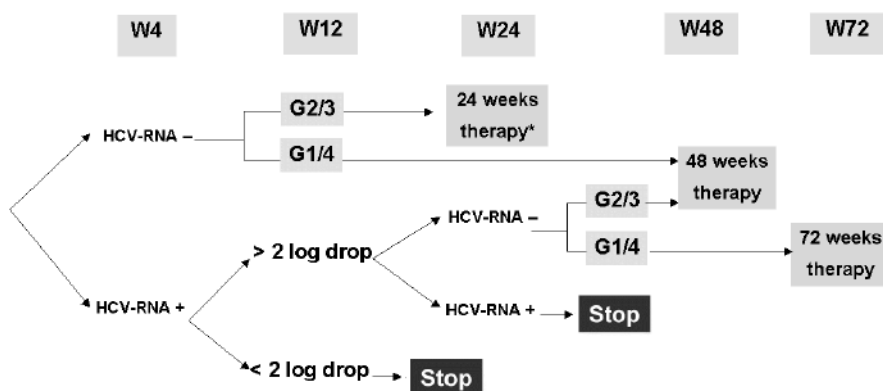
	ACTG5071	APRICOT	RIBAVIC	Laguno	PRESCO
Patients (n)	66	289	194	52	389
PEG-IFN $\alpha$	2a	2a	2b	2b	2a
IV drug use	-	62%	80%	75%	90%
Liver cirrhosis	11%	15%	39% (F3-F4)	19%	28% (F3-F4)
Genotype 1,4	77%	67%	61%	63%	61%
Normal ALT	34%	0%	16%	0%	0%
Mean CD4+	495	520	477	570	546
HAART	85%	83%	83%	94%	74%
Discontinuation rate due to AE*	12%	25%	17%	17%	9%
Discontinuation rate due to other reasons	-	31%	39%	23%	7%
EOT (ITT)**	41%	49%	35%	52%	67%
SVR (ITT)***	27%	40%	27%	44%	50%

\*adverse events, \*\*end-of-treatment response, intent-to-treat analysis, \*\*\*sustained virological response, intent-to-treat

The standard dosage for PEG-IFN  $\alpha$ -2a is 180  $\mu$ g s.c. once weekly and for PEG-IFN  $\alpha$ -2b 1.5  $\mu$ g/kg body weight s.c. once weekly. Duration of therapy is individualized taking into account factors for HCV treatment response such as genotype, baseline viral load and virologic response (see Figure 1). Results from the PRESCO trial indicate that at least some patients may benefit from a longer duration of HCV combination therapy, of up to 72 weeks (see Figure 1). This mainly refers to patients infected with HCV genotypes 1 and 4 (Núñez 2007) for whom poorer response rates have been extensively shown when compared with genotypes 2 and 3.

Based on 4 baseline variables (serum HCV RNA, HCV genotype, liver fibrosis staging using elastometry, and IL28B genotyping), the Prometheus index has recently been developed and can optionally be used as a risk calculator for predicting the likelihood of SVR using PEG-IFN/ribavirin therapy in HIV-HCV-coinfected patients. It is freely available on the web (<http://goo.gl/oPBJ9>), like the Framingham score for predicting cardiovascular risk (EACS 2011).

With the registration of the first oral direct acting antivirals (DAAs) telaprevir and boceprevir, treatment recommendations for hepatitis C genotype 1 patients will change depending on the availability of these new agents. So far, only interim data is available for both agents (24-week treatment response data) showing significantly higher rates of undetectable HCV RNA with triple therapy when compared with standard PEG-IFN plus ribavirin in coinfecting patients, similar to the rates seen in Phase II and III trials in HCV mono-infection (Sherman 2011, Sulikowski 2011). For patients with HCV genotype 1 infection, telaprevir can be added to PEG-IFN/RBV standard treatment for 12 weeks at 750 mg every 8 hours. In case of successful treatment response at week 4 (HCV RNA <1000 IU/mL), telaprevir should be continued until week 12. If HCV RNA at week 12 is still <1000 IU/mL, dual therapy with PEG-IFN/RBV should be continued until week 24. If HCV RNA is <20 IU/mL at week 24, dual therapy with PEG-IFN/RBV should be continued for another 24 weeks resulting in a total treatment duration of 48 weeks.



**Figure 1. Algorithm for management of hepatitis C in HIV coinfection.** Proposed optimal duration of hepatitis C virus (HCV) therapy in HIV/HCV-coinfecting patients (w: week; G: genotype) (modified according to Rockstroh 2009).

\*In patients with low baseline viral load (<400,000 IU/l) and minimal liver fibrosis.

Due to drug-drug interactions and limited drug-interaction studies, telaprevir can currently only be safely combined with raltegravir, boosted atazanavir or efavirenz (with efavirenz, telaprevir doses need to be increased to 1125 mg every 8 hours) in combination with tenofovir and emtricitabine or abacavir and lamivudine. Recently published pharmacokinetic (PK) data on the combination of telaprevir with raltegravir shows no influence on telaprevir PK, but telaprevir increased raltegravir levels by about 30%. This interaction is not considered clinically significant and suggests that these drugs can be used together without dose adjustment or concerns regarding effect on safety or efficacy (van Heeswijk 2011). Treatment with boceprevir for patients with HCV genotype 1 infection is different, with a mandatory 4-week lead-in Phase with PEG-IFN/RBV to reduce hepatitis C viral load and subsequently lower the risk of rapidly developing resistance against boceprevir. If a >2 log drop in HCV RNA is achieved at week 4 boceprevir is added

to PEG-IFN/RBV. Therapy duration then depends on response rates at subsequent time-points. So far, no official recommendations exist as clinical trials are ongoing.

While boceprevir seemed to have a lower potential for drug-drug interactions with ART vs. telaprevir due to its simultaneous metabolism by the aldo-keto reductase and the cytochrome P450 pathway (Dore 2011), recent study results have changed that view. Coadministration of boceprevir reduced mean trough concentrations of ritonavir-boosted atazanavir, lopinavir and darunavir by 49, 43 and 59 percent, respectively. Mean reductions of 34 to 44 percent and 25 to 36 percent were observed in AUC and C<sub>max</sub> of atazanavir, lopinavir and darunavir. Coadministration of ritonavir-boosted atazanavir with boceprevir did not alter the exposure of boceprevir, but coadministration of boceprevir with lopinavir/ritonavir or ritonavir-boosted darunavir decreased the exposure of boceprevir by 45 and 32 percent, respectively. Due to these interactions the concomitant use of boceprevir with HIV protease inhibitors is not recommended (Merck 2012).

Unlike HAART, HCV treatment offers the possibility of eradicating HCV within defined treatment periods and this clearly appears potentially advantageous for the subsequent management of the patient's HIV infection. Every patient should be considered for HCV treatment when the benefits of therapy outweigh the risks. Benefits of therapy also need to be measured in the context of rapid liver fibrosis progression in HIV/HCV coinfection and improved HCV treatment outcome under optimized management in these patients. Information on liver fibrosis staging is important for making treatment decisions in coinfecting patients. However, a liver biopsy is not mandatory for decisions on treatment of chronic HCV infection. Recently introduced noninvasive markers such as blood tests or transient elastography constitute new and exciting means of assessing liver disease in HIV and hepatitis-coinfecting individuals (Rockstroh 2009, Resino 2011). When liver biopsy or non-invasive tests for assessing hepatic fibrosis (e.g., elastometry by Fibroscan®, Echosense, France) demonstrate lower grades of liver fibrosis (F0-F1) regardless of HCV genotype, treatment can be deferred. Assessment of fibrosis should be repeated frequently to monitor progression. It is especially important to perform a liver disease stage assessment in patients with a low likelihood of achieving SVR. In addition, insulin resistance (which can be determined using the homeostasis model assessment of insulin resistance [HOMA-IR] score) has been reported as a negative predictor of achieving SVR and therefore may also be considered during evaluation.

Current therapy is particularly recommended in all patients with a high likelihood of achieving an SVR, i.e., patients infected with genotype 2 or 3 and those infected with genotype 1 if the viral load is below 600,000 IU/ml and/or if the IL28B-CC genotype is present (EACS 2011). If chronic hepatitis C is detected early in the course of HIV infection (before the initiation of HAART) treatment for chronic HCV is advised. However, if a coinfecting patient has severe immune deficiency (CD4 count <200 cells/ml), the CD4 count should be improved using HAART before beginning HCV treatment. Patients with a CD4 relative percentage of >25% are more likely to achieve SVR than those with lower CD4 percentages (Opravit 2008). If an early virologic response of at least 2 log<sub>10</sub> reduction in HCV RNA compared with baseline is not achieved by week 12, treatment should be discontinued as an SVR is unlikely. The current European recommendations for treatment initiation of PEG-INF and ribavirin for HIV/HCV-coinfecting patients are

shown in Figure 1. The procedures for diagnosis of hepatitis C, assessment of liver disease stage and control examinations before and during HCV therapy are summarized in Table 3.

**Table 3. Diagnostic procedures for hepatitis C in HIV coinfection** (adapted from Rockstroh 2008).

<b>Diagnosis of hepatitis C</b>
HCV Ab (positive 1-5 months after infection, may rarely be lost with immunosuppression)
HCV RNA levels (while not prognostic for progression, it is for response to treatment)
<b>Status of liver damage</b>
Grading of fibrosis (e.g., Fibroscan, liver biopsy, serum fibromarkers)
Hepatic synthetic function (e.g., coagulation, protein, albumin, CHE)
Ultrasound and AFP every 6 months in cirrhotics (gastroscopy upon diagnosis of cirrhosis and every 1-2 years thereafter)
<b>Before HCV treatment</b>
HCV genotype and serum HCV RNA

## The choice of antiretrovirals while on HCV therapy

The choice of the best-tolerated HIV drugs is crucial for completing the planned treatment duration of hepatitis C therapy of 24-72 weeks (Vogel 2010). ddI use has been independently associated with increased adverse event rates including lactic acidosis and hepatic decompensation in patients who have liver cirrhosis prior to commencement of PEG-IFN/RBV therapy (Mauss 2006). Apparently, ribavirin enhances the phosphorylation of ddI and thereby leads to an increased risk of pancreatitis and mitochondrial toxicity in subjects receiving concomitant ribavirin and ddI therapy (Moreno 2004). ddI use is therefore contraindicated in combination with ribavirin, especially in patients who have already developed liver cirrhosis. The use of HIV antiretrovirals such as AZT and d4T are also discouraged whenever possible, as increased toxicity can be expected. RBV + AZT is associated with enhanced anemia (Alvarez 2006) while RBV + d4T is associated with increased mitochondrial toxicity and weight loss and a high potential to worsen pre-existing lipodystrophy. Patients on atazanavir-containing HAART may develop jaundice due to an increase in total serum bilirubin levels following initiation of ribavirin (Rodriguez-Novoa 2008). As abacavir and ribavirin are both guanosine analogs it is speculated that there may be interference or competition in the phosphorylation pathway. Data from cohorts using lower dosages of ribavirin suggest lower SVR results in patients on abacavir-containing HAART (Bani-Sadr 2007). However, in the presence of therapeutic ribavirin levels no difference was observed between abacavir and other nucleosides in achieving SVR in HIV/HCV-coinfected patients receiving PEG-IFN/ribavirin therapy and concomitant HAART in other cohorts (Laufer 2008, Amorosa 2010, Berenguer 2011).

## Treatment of HCV for relapsers or non-responders

Patients with a history of previous HCV therapy who were either non-responders or who relapsed while on previous HCV therapy need to be reassessed with regard to new HCV treatment optimizing the dose and duration (see Table 4) as well as potentially adding a new HCV protease inhibitor in HCV GT 1 patients. As soon as

sustained virologic response results from currently ongoing pilot trials of the new HCV protease inhibitors in HIV/HCV coinfection become available, treatment recommendations for hepatitis C genotype 1 in HIV-positive patients will change. Recent results from the SLAM-C trial (ACTG 5178) have attenuated hopes that maintenance therapy with PEG-IFN might be beneficial for non-responders.

**Table 4. Classification of and interventions for HCV/HIV-coinfected patients who are non-responders/relapsers to prior IFN-based therapies.**

Category	Subgroup	Recommended intervention
Suboptimal treatment	Suboptimal schedule <ul style="list-style-type: none"> <li>• Interferon monotherapy</li> <li>• Low doses of ribavirin</li> <li>• Short length of therapy</li> </ul>	Re-treatment using combination therapy of PEG-IFN $\alpha$ plus weight-based dose of ribavirin
	Limiting toxicities & poor adherence	Optimal support (SSRI, paracetamol/NSAID*, adherence support, use of hematopoietic growth factors**)
Optimal treatment with virologic failure	Relapse (HCV RNA negative at the end of treatment)	Re-treatment using combination therapy of PEG-IFN plus weight-based ribavirin dosing (consider longer treatment duration)
	Non-response (no HCV RNA negativization during treatment)	Wait until new antivirals become available either through clinical trials or upon licensure

\*NSAID, non-steroidal anti-inflammatory drugs; PEG, polyethylene glycol; SSRI, selective serotonin reuptake inhibitors.

\*\*Data on the use of hematopoietic growth factors in HIV/HCV co-infection so far is limited to an improvement in quality of life but not antiviral efficacy; treatment with growth factors is currently mostly off-label in Europe.

## Treatment of acute HCV in HIV

As SVR rates following treatment of acute HCV infection are higher than for treatment of chronic HCV, HCV RNA should be measured at initial presentation and 4 weeks later in patients with acute HCV infection. Treatment should be offered in patients without a decrease of 2  $\log_{10}$  of HCV RNA at 4 weeks compared with initial HCV RNA and to patients with persistent serum HCV RNA 12 weeks after diagnosis of acute HCV. Duration of treatment should be based on rapid virologic response (RVR) regardless of genotype. Patients who do not achieve a  $\geq 2 \log_{10}$  decrease in HCV RNA level at week 12 should discontinue therapy (NEAT 2010). Uncontrolled pilot studies of treatment of acute HCV infection in HIV-coinfected

patients demonstrate SVR rates above 60% mostly with combination therapy of PEG-IFN/RBV for 24-48 weeks (Boesecke 2011). Furthermore, recently presented data from a large European cohort for the first time revealed the beneficial influence of GT 2/3 infection on treatment outcomes in the setting of acute hepatitis C suggesting different cure rates depending on HCV genotype similar to the genotype effects seen in chronic HCV therapy. In this cohort, patients with GT 2/3 infection were almost three times more likely to reach SVR than patients with GT 1/4 infection (Boesecke 2011). Unfortunately, clear guidance on treatment duration or the role of ribavirin is difficult at this point due to the lack of controlled data.

## **Liver transplantation in HIV/HCV-coinfected patients**

In general, HIV/HCV-coinfected individuals develop more rapid HCV-related hepatic injuries such as liver fibrosis and cirrhosis. Additionally, HIV/HCV coinfection is associated with an increased rate of hepatocellular carcinoma (HCC). Typically HCC occurs in HIV/HCV-coinfected patients at an earlier age and the course is more aggressive with a shorter survival compared to HCV-monoinfected individuals. Therefore, the presence of esophageal varices using upper-gastrointestinal endoscopy should be monitored in patients with liver cirrhosis every 1-2 years, and an ultrasound of the liver and a serum  $\alpha$ -fetoprotein determination should be performed at least every 6 months in patients with F3/F4 fibrosis according to the recommendations of the European Consensus Guidelines (Alberti 2005).

Liver transplantation should be considered in patients with decompensated liver cirrhosis, as this is a contraindication for HCV treatment. To fulfill the selection criteria for a liver transplant in HIV/HCV-coinfected individuals the CD4+ count has to be at least 100 cells/ml. Additionally, the patient has to have either undetectable HIV viremia (<400 copies/ml) or at least rational treatment options to control HIV infection successfully after liver transplantation. Further contraindications for transplantation are opportunistic diseases, ongoing alcohol or drug abuse, HCC metastasis in other organs, a second malignant disease, cardiopulmonary disease or older age with an elevated risk of mortality related to the operation. Recent data from a large US cohort sheds light on survival rates after liver transplantation (Mindikoglu 2008). The estimated 2-year survival rate was found to be somewhat lower in HIV-positive patients (70%) compared with HIV-negative patients (81%). This was mostly attributable to HBV or HCV coinfection. Other studies have shown good outcome results in the setting of HBV/HIV coinfection when compared to HBV mono-infection (Vogel 2005, Baccarani 2011). This highlights the major problem in HCV/HIV-coinfected transplant recipients: HCV re-infection of the transplanted organ. Recurrence of chronic hepatitis C in the liver graft is frequently observed in HIV-positive patients and a more rapid progression to graft cirrhosis and liver disease-related mortality compared to HCV-monoinfected patients has been reported. Therefore, combination therapy with pegylated interferon plus ribavirin seems to be the best management option 1-3 months after liver transplantation and after re-infection with hepatitis C virus is detected.



In the context of post-transplant immunosuppression, it is important to point out that there are crucial pharmacokinetic drug-drug interactions at the level of the cytochrome P450 metabolism and P-glycoprotein induction between the key immunosuppressive drugs tacrolimus or cyclosporin A and the antiretroviral agents used for HIV therapy. In addition the HCV protease inhibitors telaprevir and boceprevir increase the drug levels of tacrolimus and cyclosporin A substantially. Determinations of the plasma levels of the antiretroviral drugs and tacrolimus or ciclosporine are necessary. Furthermore, the doses of cyclosporin A or tacrolimus usually need to be reduced when the patient is treated concomitantly with an HIV protease inhibitor, especially if boosted with ritonavir (Vogel 2004). By contrast, NNRTIs can lower the concentrations of immunosuppressive drugs. The increase of drug levels of tacrolimus and to a lesser extent ciclosporin A by telaprevir may prevent the concomitant use of these drugs with telaprevir.

## Conclusion

HIV has been shown to accelerate the progression of hepatitis C and to result in higher liver disease-related mortality and morbidity in HIV/HCV-coinfected patients compared to HCV- or HIV-monoinfected individuals. Enhanced hepatotoxicity of HAART as well as drug-drug interactions between HAART and ribavirin clearly underline the need for specific treatment strategies. A number of important clinical studies have established PEG-IFN plus ribavirin combination therapy as the current gold standard allowing sustained virologic response rates of almost 50% in HIV/HCV-coinfected individuals under optimized management conditions (weight-based ribavirin and individualized treatment duration).

Nevertheless, the proportion of patients not treatable or those who relapse, especially in patients with genotype 1 infection, remains high. However as soon as sustained viral response results from currently ongoing pilot trials of the new HCV protease inhibitors in HIV/HCV coinfection become available treatment recommendations for hepatitis C genotype 1 in HIV patients will change.

## References

- Alberti A, Clumeck N, Collins S, et al. ECC Jury. Short statement of the first European Consensus Conference on the treatment of chronic hepatitis B and C in HIV co-infected patients. *J Hepatol.* 2005;42:615-24. ([Abstract](#))
- Alvarez D, Dieterich DT, Brau N, Moorehead L, Ball L, Sulkowski MS. Zidovudine use but not weight-based ribavirin dosing impacts anaemia during HCV treatment in HIV-infected persons. *J Viral Hepat.* 2006;13:683-9. ([Abstract](#))
- Amorosa VK, Slim J, Mounzer K, et al. The influence of abacavir and other antiretroviral agents on virological response to HCV therapy among antiretroviral-treated HIV-infected patients. *Antivir Ther.* 2010;15:91-9. ([Abstract](#))
- Baccarani U, Adani GL, Bragantini F, et al. Long-term outcomes of orthotopic liver transplantation in human immunodeficiency virus-infected patients and comparison with human immunodeficiency virus-negative cases. *Transplant Proc.* 2011;43:1119-22. ([Abstract](#))
- Bani-Sadr F, Denoed L, Morand P, et al. Agence Nationale pour la Recherche contre le SIDA et les Hépatites Virales HC02-Ribavic Study Team. Early virologic failure in HIV-coinfected hepatitis C patients treated with the peginterferon-ribavirin combination: does abacavir play a role? *J Acquir Immune Defic Syndr.* 2007;45:123-5. ([Abstract](#))

## 314 Hepatology 2012

- Benhamou Y, Demartino V, Boche T et al: Factors effecting liver fibrosis in human immunodeficiency virus and hepatitis C virus coinfecting patients. Impact of protease inhibitor therapy. *Hepatology* 2001;34:283-7. (Abstract)
- Berenguer J, González-García J, López-Aldeguer J, Von-Wichmann MA, Quereda C, Hernando A, et al. Pegylated interferon  $\alpha$ -2a plus ribavirin versus pegylated interferon  $\alpha$ -2b plus ribavirin for the treatment of chronic hepatitis C in HIV-infected patients. *J Antimicrob Chemother.* 2009;63:1256-63. (Abstract)
- Berenguer J, von Wichmann MA, Quereda C, et al. Effect of accompanying antiretroviral drugs on virological response to pegylated interferon and ribavirin in patients co-infected with HIV and hepatitis C virus. *J Antimicrob Chemother.* 2011;66:2843-9. (Abstract)
- Bevilacqua E, Fabris A, Floreano P, Pembrey L, Newell ML, Tovo PA, Amoroso A; EPHN collaborators. Genetic factors in mother-to-child transmission of HCV infection. *Virology* 2009;390:64-70. (Abstract)
- Boesecke C, Rockstroh JK. Treatment of acute hepatitis C infection in HIV-infected patients. *Curr Opin HIV AIDS.* 2011;6:278-84.
- Boesecke C, Stellbrink HJ, Mauss S, et al. Does Baseline HCV Genotype Have an Impact upon Treatment Outcome of Acute HCV Infection in HIV Co-Infected Individuals? 18th Conference on Retroviruses and Opportunistic Infections, Boston, U.S.A. 2011, Abstract #Q-138.
- Bollepalli S, Mathieson K, Bay C, Hillier A, Post J, Van Thiel DH, Nadir A. Prevalence of risk factors for hepatitis C virus in HIV-infected and HIV/hepatitis C virus-coinfecting patients. *Sex Transm Dis.* 2007 Jun;34:367-70. (Abstract)
- Centers for Disease Control and Prevention (CDC). Sexual transmission of hepatitis C virus among HIV-infected men who have sex with men--New York City, 2005-2010. *MMWR Morb Mortal Wkly Rep.* 2011;60:945-50. (Abstract)
- Clausen LN, Weis N, Astvad K, et al. Interleukin-28B polymorphisms are associated with hepatitis C virus clearance and viral load in a HIV-1-infected cohort. *J Viral Hepat.* 2011;18:e66-74. (Abstract)
- Cribier B, Rey D, Schmitt C et al: High hepatitis C viremia and impaired antibody response in patients coinfecting with HIV. *AIDS* 1995; 9: 1131-1136. (Abstract)
- Danta M, Semmo N, Fabris P, Brown D, Pybus OG, Sabin CA, et al. Impact of HIV on host-virus interactions during early hepatitis C virus infection. *J Infect Dis.* 2008;197:1558-66. (Abstract)
- Danta M, Brown D, Bhagani S, et al. and Acute HCV (HAAC) group. Recent epidemic of acute hepatitis C virus in HIV-positive men who have sex with men linked to high-risk sexual behaviours. *AIDS.* 2007;21:983-91. (Abstract)
- Darby SC, Ewart DW, Giangrande PL, et al. Mortality from liver cancer and liver disease in haemophilic men and boys in UK given blood products contaminated with hepatitis C. UK Haemophilia Centre Directors' Organisation. *Lancet* 1997; 350: 1425-1431. (Abstract)
- Dore GJ, Matthews GV, Rockstroh J. Future of hepatitis C therapy: development of direct-acting antivirals. *Curr Opin HIV AIDS.* 2011;6:508-13. (Abstract)
- European AIDS Clinical Society. EACS Guidelines. Version 6.0, October 2011. [http://www.europeanaidsclinicalociety.org/images/stories/EACS-Pdf/eacsguidelines-v6\\_english.pdf](http://www.europeanaidsclinicalociety.org/images/stories/EACS-Pdf/eacsguidelines-v6_english.pdf)
- Eyster ME, Diamondstone LS, Lien JM et al: Natural history of hepatitis C virus infection in multitransfused hemophiliacs: effect of coinfection with human immune deficiency virus - a multicenter hemophiliac cohort study. *J Acquir Immune Def Syndr* 1993; 6: 602-610. (Abstract)
- Fialaire P, Payan C, Vitour D et al: Sustained disappearance of hepatitis C viremia in patients receiving protease inhibitor therapy for human immunodeficiency virus infection. *J Infect Dis* 1999; 180: 574-575. (Abstract)
- Giordano TP, Kramer JR, Soucek J, Richardson P, El-Serag HB. Cirrhosis and hepatocellular carcinoma in HIV-infected veterans with and without the hepatitis C virus: a cohort study, 1992-2001. *Arch Intern Med.* 2004;164:2349-54. (Abstract)
- Gotz HM, van Doormun G, Niesters HG et al: A cluster with acute hepatitis C virus infection among men who have sex with men - results from contact tracing and public health implications. *AIDS* 2005; 19: 969-974. (Abstract)
- Grebely J, Petoumenos K, Hellard M, et al; ATACH Study Group. Potential role for interleukin-28B genotype in treatment decision-making in recent hepatitis C virus infection. *Hepatology.* 2010;52:1216-24. (Abstract)

- Greub G, Ledergerber B, Battegay M et al: Clinical progression, survival and immune recovery during antiretroviral therapy in patients with HIV-1 and hepatitis C virus coinfection. *Lancet* 2003; 356: 1800-1805. ([Abstract](#))
- Jin F, Prestage GP, Matthews GV, Zablotska I, Rawston P, Kippax SC, Kaldor J, Grulich AE. Prevalence, incidence and risk factors for hepatitis C in homosexual men: Data from two cohorts of HIV negative and HIV positive men in Sydney, Australia. *Sex Transm Infect.* 2010; 86:25-8.
- Kaufmann GR, Perrin L, Pantaleo G, et al. CD4 T-lymphocyte recovery in individuals with advanced HIV-1 infection receiving potent antiretroviral therapy for 4 years: the Swiss HIV Cohort Study. *Arch Intern Med* 2003; 163: 2187-2195. ([Abstract](#))
- Laufer N, Laguno M, Perez I, Cifuentes C, Murillas J, Vidal F, et al. Abacavir does not influence the rate of virological response in HIV-HCV-coinfected patients treated with pegylated interferon and weight-adjusted ribavirin. *Antivir Ther.* 2008;13:953-7. ([Abstract](#))
- Matthews GV, Pham ST, Hellard M, et al. Patterns and characteristics of hepatitis C transmission clusters among HIV-positive and HIV-negative individuals in the Australian trial in acute hepatitis C. *Clin Infect Dis.* 2011;52:803-11. ([Abstract](#))
- Mauss S, Valenti W, DePamphilis J, et al. Risk factors for hepatic decompensation in patients with HIV/HCV coinfection and liver cirrhosis during interferon-based therapy. *AIDS.* 2004;18:F21-25. ([Abstract](#))
- Merck. Dear Healthcare Professional Important Healthcare Warning. Results of Pharmacokinetic Study in Healthy Volunteers Given VICTRELIS™ (boceprevir) and Ritonavir-Boosted HIV Protease Inhibitors May Indicate Clinically Significant Drug Interactions for Patients Coinfected with Chronic Hepatitis C and HIV. DHPP-letter-3-FEB.pdf. 2012.
- Mindikoglu AL, Regev A, Magder LS. Impact of human immunodeficiency virus on survival after liver transplantation: analysis of United Network for Organ Sharing database. *Transplantation* 2008;85:359-68. ([Abstract](#))
- Moreno A, Quereda C, Moreno L, Perez-Elías MJ, Muriel A, Casado JL, et al. High rate of didanosine-related mitochondrial toxicity in HIV/HCV-coinfected patients receiving ribavirin. *Antivir Ther.* 2004;9:133-8. ([Abstract](#))
- Nattermann J, Vogel M, Nischalke HD, et al. Genetic Variation in IL28B and Treatment-Induced Clearance of Hepatitis C Virus in HIV-Positive Patients With Acute and Chronic Hepatitis C. *J Infect Dis.* 2011;203:595-601. ([Abstract](#))
- The European AIDS Treatment Network (NEAT) Acute Hepatitis C Infection Consensus Panel. Acute hepatitis C in HIV-infected individuals: recommendations from the European AIDS Treatment Network (NEAT) consensus conference. *AIDS.* 2011;25:399-409. ([Abstract](#))
- Nunez M, Miralles C, Berdun MA, et al for the PRESCO study group: Role of weight-based ribavirin dosing and extended duration of therapy in chronic hepatitis C in HIV-infected patients: The PRESCO trial. *AIDS Res Hum Retrovir* 2007, 23: 972-982. ([Abstract](#))
- Opravil M, Sasadeusz J, Cooper DA, et al: Effect of baseline CD4 cell count on the efficacy and safety of peg-interferon-a 2a (40 kd) + ribavirin in patients with HIV-HCV coinfection. *J Acquir Immune Def Syndr* 2008; 47: 36-49. ([Abstract](#))
- Perez-Olmeda M, Rios P, Nunez M, Garcia-Samaniego J, Romero M, Soriano V. Virological characteristics of hepatitis C virus infection in HIV-infected individuals with chronic hepatitis C: implications for treatment. *AIDS* 2002; 16: 493-495. ([Abstract](#))
- Peters L, Mocroft A, Soriano V, Rockstroh JK, Losso M, Valerio L, et al. Hepatitis C virus coinfection does not influence the CD4 cell recovery in HIV-1-infected patients with maximum virologic suppression. *J Acquir Immune Defic Syndr.* 2009;50:457-63. ([Abstract](#))
- Pineda JA, García-García JA, Aguilar-Guisado M, et al. Grupo para el Estudio de las Hepatitis Viricas de la Sociedad Andaluza de Enfermedades Infecciosas (SAEI). Clinical progression of hepatitis C virus-related chronic liver disease in human immunodeficiency virus-infected patients undergoing highly active antiretroviral therapy. *Hepatology.* 2007;46:622-30.
- Pol S, Thiers V, Nousbaum J, et al. Changing distribution of HCV genotypes in Europe in the last decades. *J Hepatol* 1994; 21: S13.
- Puoti M, Bonacini M, Spinetti A, Putzolu V, Govindarajan S, Zaltron S, et al. Liver fibrosis progression is related to CD4 cell depletion in patients coinfecting with hepatitis C virus and human immunodeficiency virus. *J Infect Dis.* 2001;183:134-7. ([Abstract](#))

## 316 Hepatology 2012

- Qian HZ, Vermund SH, Kaslow RA, et al. Co-infection with HIV and hepatitis C virus in former plasma/blood donors: challenge for patient care in rural China. *AIDS* 2006; 20: 1429-1435. (Abstract)
- Qurishi N, Kreuzberg C, Lüchters G et al. Effect of antiretroviral therapy on liver-related mortality in patients with HIV and hepatitis C coinfection. *Lancet* 2003; 362: 1708-1713. (Abstract)
- Rauch A, Kutalik Z, Descombes P, et al. Genetic variation in IL28B is associated with chronic hepatitis C and treatment failure: a genome-wide association study. *Gastroenterology* 2010;138:1338-1345. (Abstract)
- Rallón NI, Soriano V, Naggie S, et al. IL28B gene polymorphisms and viral kinetics in HIV/hepatitis C virus-coinfected patients treated with pegylated interferon and ribavirin. *AIDS*. 2011;25:1025-33. (Abstract)
- Resino S, Asensio C, Bellón JM, et al. Diagnostic accuracy of the APRI, FIB-4, and the Forns index for predicting liver fibrosis in HIV/HCV-coinfected patients: A validation study. *J Infect*. 2011;63:402-5. (Abstract)
- Rockstroh JK, Spengler U, Sudhop T, et al: Immunosuppression may lead to progression of hepatitis C virus associated liver disease in hemophiliacs coinfecting with HIV. *Am J Gastroenterol* 1996; 91: 2563-2568. (Abstract)
- Rockstroh JK, Theisen A, Kaiser R, et al: Antiretroviral triple therapy decreases the HIV viral load and does not alter hepatitis C virus serum levels in HIV/HCV-coinfected hemophiliacs. *AIDS* 1998; 12: 829-830. (Abstract)
- Rockstroh JK, Spengler U. HIV and HCV coinfection. *Lancet Infect Dis* 2004; 4: 437-444. (Abstract)
- Rockstroh JK, Mocroft A, Soriano V, et al: Influence of hepatitis C virus infection on HIV-1 disease progression and response to highly antiretroviral therapy. *J Infect Dis* 2005; 192: 992-1002. (Abstract)
- Rockstroh JK. Hot topics in HIV and hepatitis coinfection: noninvasive diagnosis of liver disease, liver transplantation, and new drugs for treatment of hepatitis coinfection. *HIV Clin Trials* 2009;10:110-5. (Abstract)
- Rodríguez-Nóvoa S, Morello J, González M, Vispo E, Barreiro P, González-Pardo G, et al. Increase in serum bilirubin in HIV/hepatitis-C virus-coinfected patients on atazanavir therapy following initiation of pegylated-interferon and ribavirin. *AIDS*. 2008;22:2535-7. (Abstract)
- Rodriguez-Torres M, Slim J, Bhatti L, Sterling RK, Sulkowski MS, Hassanein T, et al. Standard versus high dose ribavirin in combination with peginterferon alfa-2a (40KD) in genotype 1 (G1) HCV patients coinfecting with HIV: Final results of the PARADIGM study. *AASLD* 2009, Abstract 1561.
- Schmidt AJ, Rockstroh JK, Vogel M, et al. Trouble with bleeding: risk factors for acute hepatitis C among HIV-positive gay men from Germany--a case-control study. *PLoS One* 2011;6:e17781. (Abstract)
- SeyedAlinaghi S, Jam S, Mehrkhani F, et al. Hepatitis-C and hepatitis-B co-infections in patients with human immunodeficiency virus in Tehran, Iran. *Acta Med Iran* 2011; 49:252-7. (Abstract)
- Sherman KE, Rockstroh JK, Dieterich DT, et al. Telaprevir in Combination with Peginterferon Alfa-2a/Ribavirin in HCV/HIV Coinfected Patients: A 24-Week Treatment Interim Analysis. The 62nd Annual Meeting of the American Association for the Study of Liver Diseases 2011, San Francisco, USA. Abstract LB-8.
- Singal AK, Anand BS. Management of hepatitis C virus infection in HIV/HCV co-infected patients: clinical review. *World J Gastroenterol*. 2009;15:3713-24. (Abstract)
- Soriano V, Mocroft A, Rockstroh J, et al. Spontaneous viral clearance, viral load, and genotype distribution of hepatitis C virus (HCV) in HIV-infected patients with anti-HCV antibodies in Europe. *J Infect Dis* 2008;198:1337-1344. (Abstract)
- Soto B, Sanchez-Quijano A, Rodrigo L, et al. Human immunodeficiency virus infection modifies the natural history of chronic parenterally-acquired hepatitis C with an unusually rapid progression to cirrhosis. *J Hepatol* 1997; 26: 1-5. (Abstract)
- Sulkowski NS, Thomas DL, Chaisson RE, Moore D. Hepatotoxicity associated with antiretroviral in adults infected with human immunodeficiency virus and the role of hepatitis C or B virus infection. *JAMA* 2000; 283: 74-80. (Abstract)
- Sulkowski MS, Moore RD, Mehta SH, et al. Hepatitis C and progression of HIV disease. *JAMA* 2002;288:199-206. (Abstract)

- Sulkowski M, Pol S, Cooper C, et al. Boceprevir Plus Peginterferon/Ribavirin for the Treatment of HCV/HIV Co-Infected Patients. Infectious Diseases Society of America, 49th Annual Meeting 2011, Boston, USA. Abstract LB-37.
- Thomas DL, Thio CL, Martin MP, et al. Genetic variation in IL28B and spontaneous clearance of hepatitis C virus. *Nature* 2009;461:798-801. ([Abstract](#))
- Thomson EC, Nastouli E, Main J, Karayiannis P, Eliahoo J, Muir D, McClure MO. Delayed anti-HCV antibody response in HIV-positive men acutely infected with HCV. *AIDS*. 2009;23:89-93. ([Abstract](#))
- Thomson E, Fleming VM, Main J, et al. Predicting spontaneous clearance of acute hepatitis C virus in a large cohort of HIV-1-infected men. *Gut*. 2011;60:837-45. ([Abstract](#))
- Torriani FJ, Rodriguez-Torres M, Rockstroh JK et al: peg-interferon-a 2a + ribavirin for chronic hepatitis C virus infection in HIV-infected patients. *New Engl J Med* 2004; 358: 438-450. ([Abstract](#))
- Turner J, Bansil L, Gilson R, Gazzard B, Walsh J, Pillay D, et al. The prevalence of hepatitis C virus (HCV) infection in HIV-positive individuals in the UK - trends in HCV testing and the impact of HCV on HIV treatment outcomes. *J Viral Hepat*. 2010; 17:569-77. ([Abstract](#))
- Van Heeswijk R, Garg V, Boogaerts G, et al. The pharmacokinetic interaction between telaprevir and raltegravir in healthy volunteers. 51st ICAAC Chicago USA 2011, Abstract A1-1738a.
- Verma S, Wang CH, Govindarajan S, Kanel G, Squires K, Bonacini M. Do type and duration of antiretroviral therapy attenuate liver fibrosis in HIV-hepatitis C virus-coinfected patients? *Clin Infect Dis*. 2006;42:262-70. ([Abstract](#))
- Vogel M, Voigt E, Michaelis HC, et al. Management of drug-to-drug interactions between cyclosporin A and the protease inhibitor saquinavir/ritonavir in liver transplanted HIV-infected patients. *Liver Transplant* 2004;10: 939-944. ([Abstract](#))
- Vogel M, Voigt E, Schäfer N, Goldmann G, Schwarz N, Kalff JC, et al. Orthotopic liver transplantation in human immunodeficiency virus (HIV)-positive patients: outcome of 7 patients from the Bonn cohort. *Liver Transpl*. 2005;11:1515-21. ([Abstract](#))
- Vogel M, Deterding K, Wiegand J, Grüner NH, Baumgarten A, Jung MC, et al. Hep-Net. Initial presentation of acute hepatitis C virus (HCV) infection among HIV-negative and HIV-positive individuals-experience from 2 large German networks on the study of acute HCV infection. *Clin Infect Dis*. 2009;49:317-9.
- Vogel M, Rockstroh JK. Liver disease: the effects of HIV and antiretroviral therapy and the implications for early antiretroviral therapy initiation. *Curr Opin HIV AIDS*. 2009;4:171-5.
- Vogel M, Rockstroh JK. Treatment of acute hepatitis C in HIV infection. *J Antimicrob Chemother*. 2010;65:4-9. ([Abstract](#))
- Vogel M, Ahlenstiel G, Hintsche B, et al. The influence of HAART on the efficacy and safety of pegylated interferon and ribavirin therapy for the treatment of chronic HCV infection in HIV-positive individuals. *Eur J Med Res* 2010; 15:102-111. ([Abstract](#))
- Weinbaum CM, Sabin KM, Santibanez SS. Hepatitis B, hepatitis C, and HIV in correctional populations: a review of epidemiology and prevention. *AIDS* 2005; 19 Suppl 3: S41-46. ([Abstract](#))
- Zanetti AR, Tanzi E, Paccagnini S, et al. Mother-to-infant transmission of hepatitis C virus. Lombard study group on vertical HCV transmission. *Lancet* 1995;345: 289-291. ([Abstract](#))

## 19. HBV/HCV Coinfection

*Carolynne Schwarze-Zander and Jürgen Kurt Rockstroh*

### **Epidemiology of HBV/HCV coinfection**

Hepatitis B (HBV) and hepatitis C (HCV) viruses are the most common causes of chronic liver disease worldwide. Due to shared routes of transmission, coinfection with HBV and HCV is not uncommon among individuals in HBV endemic areas who also have a high risk of parenteral infections, such as injection drug users (Pallas 1999), patients on hemodialysis (Reddy 2005), patients undergoing organ transplantation (Aroldi 2005) and HIV-positive individuals (Zhou 2007). Due to a lack of large-scale population-based studies the exact number of HBV/HCV coinfecting patients is unknown. Dual infection ranges from 9% to 30%, depending on the geographic region (Zarski 1998, Liaw 1995). These numbers may underestimate the true number of people with HBV/HCV coinfection as there is a well-known entity of occult HBV infection (patients with negative hepatitis B surface antigen [HBsAg] but detectable serum HBV DNA) in patients with chronic hepatitis C (Cacciola 1999).

### **Screening for HBV/HCV coinfection**

Persons with a first episode of acute hepatitis should be screened for all viral causes including HBV and HCV (see Chapter 8 on diagnostic tests in acute and chronic hepatitis B and Chapter 12 for hepatitis C). Some patients may be inoculated with both viruses simultaneously and will present with acute hepatitis due to both viruses. In addition, HBV superinfection in patients with chronic hepatitis C, and HCV superinfection in patients with chronic hepatitis B have both been reported (Liaw 2004, Liaw 2000, Liaw 2002). Therefore, episodes of acute hepatitis in patients with known chronic HBV or HCV infection, especially those with ongoing risk behaviour for infection with the other virus such as injection drug users, should prompt screening for superinfection. In addition, in patients with chronic hepatitis C, ruling out occult HBV infection beyond HBsAg testing, i.e., by polymerase chain reaction (PCR), should be done when clinically indicated.

## Viral interactions between HBV and HCV

Patients with both HBV and HCV infections may show a large spectrum of virologic profiles. HCV infection can suppress HBV replication and it has been shown that HBV/HCV-coinfected patients have lower HBV DNA levels, decreased activity of HBV DNA polymerase, and decreased expression of HBsAg and hepatitis B core antigen in the liver (Chu 1998). Moreover, patients with chronic HBV infection who become superinfected with HCV can undergo seroconversion of HBsAg (Liaw 1994, Liaw 1991). Several authors have reported that HBV can reciprocally inhibit HCV replication as well (Sato 1994). Specifically, HBV DNA replication has been shown to correlate with decreased HCV RNA levels in coinfecting patients (Zarski 1998). Furthermore, coinfecting patients have been shown to have lower levels of both HBV DNA and HCV RNA than corresponding mono-infected controls, indicating that simultaneous suppression of both viruses by the other can also occur (Jardi 2001). Thus, HBV or HCV can play the dominant role, HBV and HCV can inhibit each other simultaneously and they can alternate their dominance (Liaw 1995). Both viruses have the ability to induce seroconversion of the other. The chronology of infection may have a role in determining the dominant virus. The overall effect appears to be HCV suppression of HBV (Liaw 2001). Interestingly, recent *in vitro* studies found no evidence of direct interference between the two viruses, making also interindividual differences in innate and/or adaptive host immune responses responsible for viral interference observed in coinfecting patients (Bellecave 2009, Eyre 2009).

## Clinical scenarios of HBV and HCV infection

Different scenarios of infection have been described with HBV/HCV coinfection including acute hepatitis with HBV and HCV (Alberti 1995), occult HBV coinfection of chronic hepatitis C (Sagnelli 2001), and superinfection by either virus in patients with preexisting chronic hepatitis due to the other virus (Figure 1). Frequently the sequence of infection cannot be defined.

### Acute hepatitis by simultaneous infection of HBV and HCV

Simultaneous coinfection with HBV and HCV is rarely seen, but the interaction of HBV and HCV appears to be similar to chronic infection. In acute infection with HBV and HCV, patients showed delayed HBsAg appearance and a shorter hepatitis B surface antigenemia compared to those with acute HBV alone (Mimms 1993). Biphasic alanine aminotransferase (ALT) elevation was found in some patients, although rates of viral clearance were similar to those in HBV or HCV mono-infected patients (Alberti 1995).

### HCV superinfection

HCV superinfection is frequent in endemic areas of HBV infection, such as Asia, South America and sub-Saharan Africa (Liaw 2002, Liaw 2004), which can result in the suppression of HBV replication and termination of HBsAg carriage. However, long-term follow-up analyses have described a higher rate of liver cirrhosis and hepatocellular carcinoma (Liaw 2004). Fulminant hepatic failure was significantly higher among patients with underlying HBV infection than those without (23% vs. 3%) (Chu 1999, Wu 1994, Chu 1994).

## HBV superinfection

HBV superinfection is less common in HCV-infected patients and very limited data is available. In one report a patient became seronegative for HCV RNA after HBV superinfection, indicating that superinfection of HBV may lead to suppression of HCV (Liaw 2000, Wietzke 1999). Other reports have shown that HBV superinfection may be associated with acute deterioration of liver function among patients with chronic HCV infection, and the risk of fulminant hepatitis may be increased (Sagnelli 2002).

## Occult HBV infection in patients with HCV infection

Occult HBV infection, defined as detectable HBV DNA in liver or serum and undetectable HBsAg (Ozaslan 2009, Torbenson 2002), has been identified in up to 50% of patients with chronic HCV. Importantly, a relation to HCV treatment outcomes has been described (Zignego 1997, Fukuda 2001, Sagnelli 2001). HCV infection with occult HBV infection has been associated with higher ALT levels, greater histological activity index and liver disease more often progressing to liver cirrhosis (Fukuda 1999, Cacciola 1999, Sagnelli 2001).

## Chronic hepatitis in HBV/HCV coinfection

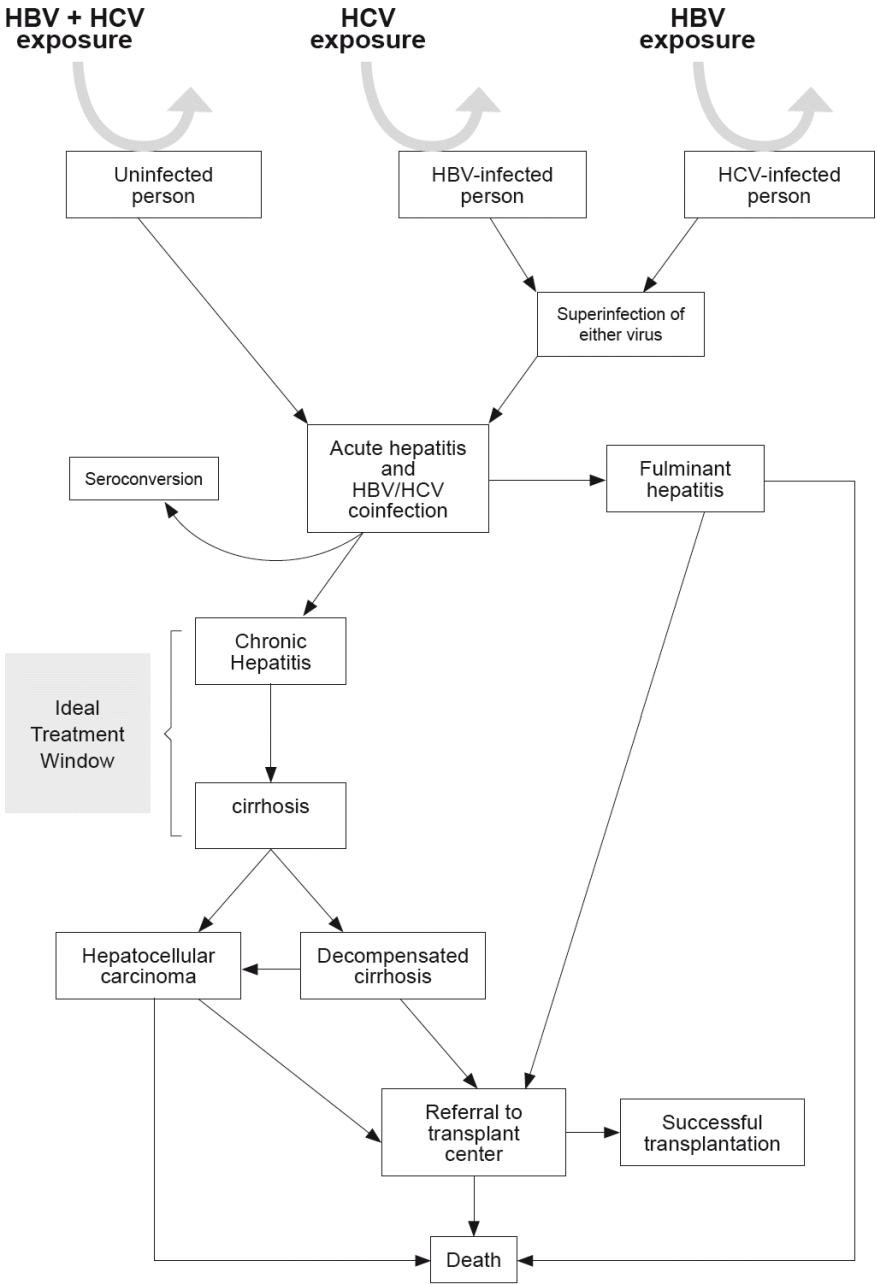
Patients with detectable serum HBV DNA and HCV RNA are at highest risk of progression to cirrhosis and liver decompensation and therefore should be considered for treatment. Active HCV infection (HCV RNA+) in the setting of inactive HBsAg (HBsAg+/HBV DNA-) behaves similarly to patients with HCV mono-infection. Another possibility is active HBV infection in patients with inactive or prior HCV infection (HBV DNA+/HCV RNA-/anti-HCV+). This immune profile is less common, and may indicate HBV suppression of HCV. A longitudinal study of virologic monitoring of 103 HBV/HCV coinfecting patients revealed fluctuation of the virological pattern (Raimondo 2006). Thus, close follow-up of levels of viremia is needed for correct diagnosis and decision on what would be the most successful treatment.

Table 1 shows the immune profiles found in patients with chronic HBV/HCV infection.

**Table 1. Immune profiles in patients with chronic HBV/HCV hepatitis.**

	HBV and HCV active	Occult HBV in chronic active HCV	HCV active in HBsAg carrier
HBsAg	+	—	+
HBV DNA	+	+	—
Anti-HCV	+	+	+
HCV RNA	+	+	+





**Figure 1. Clinical scenarios of HBV/HCV coinfection** (modified after Crockett & Keeffe 2005).

## Cirrhosis

Higher rates of cirrhosis have been demonstrated in HBV/HCV-coinfected patients. In comparison to patients with HBV monoinfection, higher rates of cirrhosis (44% vs. 21%) and decompensated liver disease (24% vs. 6%) were demonstrated in coinfecting patients (Fong 1991). Compared to HCV monoinfected patients a higher rate of cirrhosis (95% vs. 49%) and more decompensated liver disease (Child-Pugh class C 37% vs. 0%) were found in HBV/HCV-coinfected patients (Mohamed Ael 1997).

## Hepatocellular carcinoma

In many studies coinfection with HBV and HCV has been shown to be associated with an increased risk of HCC development (Kaklamani 1991, Mohamed Ael 1997).

In one longitudinal study incidence of HCC was 6.4 per person years in HCV/HBV-coinfected patients compared to 2.0 in HBV and 3.7 in HCV monoinfection. The cumulative risk of developing HCC after 10 years was 45% in HBV/HCV-coinfected patients compared to 16% in HBV- and 28% in HCV-monoinfected patients (Chiaromonte 1999). HBV/HCV-coinfected patients should undergo a screening routine for HCC with liver ultrasound and  $\alpha$ -fetoprotein levels in serum at least every 6 months.

## Treatment of HBV and HCV coinfection

Currently there are no well-established treatment guidelines for HBV/HCV-coinfected patients. Generally, treatment guidelines for monoinfected patients should be applied to coinfecting patients. In patients with HBV/HCV coinfection treatment should be initiated when inclusion criteria for standard treatment guidelines of HBV and HCV monoinfection are met (see Chapter 9 on therapy of HBV and Chapter 13 on treatment of HCV). As with HBV and HCV monoinfection, treatment of coinfecting patients should be started in patients with active chronic hepatitis or cirrhosis before liver decompensation occurs. Due to the variety of virological profiles in HBV/HCV coinfection it is important to assess the dominant virus prior to initiating therapy.

Due to loss of viral suppression from the successfully treated dominant virus, deterioration of liver disease has been reported (Yalcin 2003), thus caution must be exercised upon initiation of therapy.

In coinfecting patients with dominance of HCV infection, treatment with IFN (Weltman 1995, Villa 2001, Utili 1999) and IFN plus ribavirin (Chuang 2005, Hung 2005, Liu 2003) has been well-studied and proven effective. However, more recent studies show that combination therapy with pegylated IFN and ribavirin are even more efficient in inducing virological results (see Table 2).

HCV RNA response was similar to results seen in HCV monoinfection with up to 83% in HCV genotype 2/3 and 72% in HCV genotype 1 achieving sustained virological response (Liu 2009). In one small study including 17 HCV/HBV-coinfected patients these successful results were not confirmed (Senturk 2008). Importantly, HBV replication may become detectable in up to 36% of patients with undetectable pretreatment HBV DNA levels (Potthoff 2009, Liu 2009). Thus, close monitoring of both viruses is recommended during and after combination therapy.

**Table 2. Peg-IFN plus ribavirin treatment trials in HBV/HCV-coinfected patients.**

Patients (n)	HCV SVR (%)	HBV DNA negative (%)	HBsAg loss (%)	HBV reactivation # (%)	Reference
19	74	33	0	31	Potthoff, 2008
161	72*, 83**	56	11	35	Liu, 2009
17	6	na	na	na	Senturk, 2008
50	40*, 75**	100	0	24	Yu, 2009

\*HCV GT1,\*\* HCV GT2/3, na=not applicable, # HBV DNA negative pretreatment

In patients with dominance of HBV disease IFN +/- HBV polymerase inhibitors are an option, although until now there is only data for lamivudine in a small cohort of 8 HBV (HBeAg and HBV DNA-pos) and HCV (HCV RNA-pos) coinfecting patients (Marrone 2004). In this study, clearance of HBeAg was found in 3/8, two patients showing HBeAg seroconversion, and clearance of HBV DNA was observed in 3/8 at the end of therapy. HBV DNA became detectable again in 2 patients at the end of follow-up. HCV clearance was observed in 50%. Based on these observations nucleos(t)ide analogs such as tenofovir, adefovir, entecavir and telbivudine showing a higher genetic barrier in combination with PEG-IFN are a possible treatment option. However, studies are needed to estimate the treatment value of these newer drugs in this clinical scenario.

## Conclusion

Coinfection with HBV and HCV is not uncommon, especially within areas of high hepatitis B prevalence. HBV/HCV coinfection is a challenge for clinicians due to the complex interaction of HBV and HCV, and the propensity for developing severe liver disease. No treatment standard has been established for HBV/HCV-coinfected patients. Treatment decisions must be made based upon identification of the dominant virus. Combination therapy of PEG-IFN plus ribavirin has been shown to be highly effective in inducing virological response of HCV in patients with HBV/HCV coinfection. The availability of direct acting antivirals against HCV will open new pathways in treatment, which should be replicated in HBV/HCV coinfection. However, to date, in coinfection of HBV/HCV no treatment experience with these new agents has been reported. Finally, caution must be exercised in treating coinfecting patients, as flares of the untreated virus may occur.

## References

- Alberti A, Pontisso P, Chemello L, et al. The interaction between hepatitis B virus and hepatitis C virus in acute and chronic liver disease. *J Hepatol* 1995;22(1 Suppl):38-41. ([Abstract](#))
- Aroldi A, Lampertico P, Montagnino G, et al. Natural history of hepatitis B and C in renal allograft recipients. *Transplantation* 2005;79:1132-6. ([Abstract](#))
- Bellecave P, Gouttenoire J, Gajer M et al. Hepatitis B and C virus coinfection: a novel model system reveals the absence of direct viral interference. *Hepatology* 2009;50:46-55. ([Abstract](#))
- Cacciola I, Pollicino T, Squadrito G, et al. Occult hepatitis B virus infection in patients with chronic hepatitis C liver disease. *N Engl J Med* 1999;341:22-6. ([Abstract](#))

- Chiaromonte M, Stroffolini T, Vian A, et al. Rate of incidence of hepatocellular carcinoma in patients with compensated viral cirrhosis. *Cancer* 1999;85:2132-7. (Abstract)
- Chu CJ, Lee SD. Hepatitis B virus/hepatitis C virus coinfection: epidemiology, clinical features, viral interactions and treatment. *J Gastroenterol Hepatol* 2008;23:512-20. (Abstract)
- Chu CM, Sheen IS, Liaw YF. The role of hepatitis C virus in fulminant viral hepatitis in an area with endemic hepatitis A and B. *Gastroenterology* 1994;107:189-95. (Abstract)
- Chu CM, Yeh CT, Liaw YF. Low-level viremia and intracellular expression of hepatitis B surface antigen (HBsAg) in HBsAg carriers with concurrent hepatitis C virus infection. *J Clin Microbiol* 1998;36:2084-6. (Abstract)
- Chuang WL, Dai CY, Chang WY, et al. Viral interaction and responses in chronic hepatitis C and B coinfecting patients with interferon-alpha plus ribavirin combination therapy. *Antivir Ther* 2005;10:125-33. (Abstract)
- Crockett SD, Keeffe EB. Natural history and treatment of hepatitis B virus and hepatitis C virus coinfection. *Ann Clin Microbiol Antimicrob* 2005;4:13. (Abstract)
- Eyre NS, Phillips RJ, Bowden S, et al. Hepatitis B virus and hepatitis C virus interaction in Huh-7 cells. *J Hepatol* 2009;51:446-57. (Abstract)
- Fong TL, Di Bisceglie AM, Waggoner JG, et al. The significance of antibody to hepatitis C virus in patients with chronic hepatitis B. *Hepatology* 1991;14:64-. (Abstract)
- Fukuda R, Ishimura N, Hamamoto S, et al. Co-infection by serologically-silent hepatitis B virus may contribute to poor interferon response in patients with chronic hepatitis C by down-regulation of type-I interferon receptor gene expression in the liver. *J Med Virol* 2001;63:220-7. (Abstract)
- Fukuda R, Ishimura N, Niigaki M, et al. Serologically silent hepatitis B virus coinfection in patients with hepatitis C virus-associated chronic liver disease: clinical and virological significance. *J Med Virol* 1999;58:201-7. (Abstract)
- Hung CH, Lee CM, Lu SN, et al. Combination therapy with interferon-alpha and ribavirin in patients with dual hepatitis B and C virus infection. *J Gastroenterol Hepatol* 2005;20:727-32. (Abstract)
- Jardi R, Rodriguez F, Buti M, et al. Role of hepatitis B, C, and D viruses in dual and triple infection: influence of viral genotypes and hepatitis B precore and basal core promoter mutations on viral replicative interference. *Hepatology* 2001;34:404-10. (Abstract)
- Liaw YF. Role of hepatitis C virus in dual and triple hepatitis virus infection. *Hepatology* 1995;22:1101-8. (Abstract)
- Liaw YF. Concurrent hepatitis B and C virus infection: Is hepatitis C virus stronger? *J Gastroenterol Hepatol* 2001;16:597-8. (Abstract)
- Liaw YF. Hepatitis C virus superinfection in patients with chronic hepatitis B virus infection. *J Gastroenterol* 2002;37 Suppl 13:65-8. (Abstract)
- Liaw YF, Chen YC, Sheen IS, et al. Impact of acute hepatitis C virus superinfection in patients with chronic hepatitis B virus infection. *Gastroenterology* 2004;126:1024-9. (Abstract)
- Liaw YF, Lin SM, Sheen IS, et al. Acute hepatitis C virus superinfection followed by spontaneous HBeAg seroconversion and HBsAg elimination. *Infection* 1991;19:250-1. (Abstract)
- Liaw YF, Yeh CT, Tsai SL. Impact of acute hepatitis B virus superinfection on chronic hepatitis C virus infection. *Am J Gastroenterol* 2000;95:2978-80. (Abstract)
- Liu CJ, Chen PJ, Lai MY et al. Ribavirin and interferon is effective for hepatitis C virus clearance in hepatitis B and C dually infected patients. *Hepatology* 2003;37:568-76. (Abstract)
- Liu CJ, Chuang WL, Lee CM, et al. Peginterferon alfa-2a plus ribavirin for the treatment of dual chronic infection with hepatitis B and C viruses. *Gastroenterology* 2009;136(2):496-504. (Abstract)
- Marrone A, Zampino R, D'Onofrio M, et al. Combined interferon plus lamivudine treatment in young patients with dual HBV (HBeAg positive) and HCV chronic infection. *J Hepatol* 2004;41:1064-5. (Abstract)
- Mimms LT, Moseley JW, Hollinger FB, et al. Effect of concurrent acute infection with hepatitis C virus on acute hepatitis B virus infection. *BMJ* 1993;307:1095-7. (Abstract)
- Mohamed Ael S, al Karawi MA, Mesa GA. Dual infection with hepatitis C and B viruses: clinical and histological study in Saudi patients. *Hepatogastroenterology* 1997;44:1404-6. (Abstract)
- Ozaslan E, Purnak T. Controversies about occult hepatitis B virus infection. *World J Gastroenterol* 2009;15:4986-7. (Abstract)

- Pallas JR, Farinas-Alvarez C, Prieto D, et al. Coinfections by HIV, hepatitis B and hepatitis C in imprisoned injecting drug users. *Eur J Epidemiol* 1999;15:699-704. ([Abstract](#))
- Potthoff A, Wedemeyer H, Boecher WO, et al. The HEP-NET B/C co-infection trial: A prospective multicenter study to investigate the efficacy of pegylated interferon-alpha2b and ribavirin in patients with HBV/HCV co-infection. *J Hepatol* 2008;49:688-94. ([Abstract](#))
- Potthoff A, Berg T, Wedemeyer H, et al. Late hepatitis B virus relapse in patients co-infected with hepatitis B virus and hepatitis C virus after antiviral treatment with pegylated interferon-a2b and ribavirin. *Scand J Gastroenterol* 2009;44:1487-90. ([Abstract](#))
- Raimondo G, Brunetto MR, Pontisso P, et al. Longitudinal evaluation reveals a complex spectrum of virological profiles in hepatitis B virus/hepatitis C virus-coinfected patients. *Hepatology* 2006;43:100-7. ([Abstract](#))
- Reddy GA, Dakshinamurthy KV, Neelaprasad P, et al. Prevalence of HBV and HCV dual infection in patients on haemodialysis. *Indian J Med Microbiol* 2005;23:41-3. ([Abstract](#))
- Sagnelli E, Coppola N, Messina V, et al. HBV superinfection in hepatitis C virus chronic carriers, viral interaction, and clinical course. *Hepatology* 2002;36:1285-91. ([Abstract](#))
- Sagnelli E, Coppola N, Scolastico C, et al. HCV genotype and "silent" HBV coinfection: two main risk factors for a more severe liver disease. *J Med Virol* 2001;64:350-5. ([Abstract](#))
- Sato S, Fujiyama S, Tanaka M, et al. Coinfection of hepatitis C virus in patients with chronic hepatitis B infection. *J Hepatol* 1994;21:159-66. ([Abstract](#))
- Senturk H, Tahan V, Canbakan B, et al. Chronic hepatitis C responds poorly to combination therapy in chronic hepatitis B carriers. *Neth J Med* 2008;66:191-5. ([Abstract](#))
- Torbenson M, Thomas DL. Occult hepatitis B. *Lancet Infect Dis* 2002;2:479-86. ([Abstract](#))
- Utili R, Zampino R, Bellopede P, et al. Dual or single hepatitis B and C virus infections in childhood cancer survivors: long-term follow-up and effect of interferon treatment. *Blood* 1999;94:4046-52. ([Abstract](#))
- Villa E, Grotola A, Buttafoco P, et al. High doses of alpha-interferon are required in chronic hepatitis due to coinfection with hepatitis B virus and hepatitis C virus: long term results of a prospective randomized trial. *Am J Gastroenterol* 2001;96:2973-7. ([Abstract](#))
- Wietzke P, Schott P, Braun F, et al. Clearance of HCV RNA in a chronic hepatitis C virus-infected patient during acute hepatitis B virus superinfection. *Liver* 1999;19:348-53. ([Abstract](#))
- Weltman MD, Brotodihardio A, Crewe EB, et al. Coinfection with hepatitis B and C or B, C and delta viruses results in severe chronic liver disease and responds poorly to interferon-alpha treatment. *J Viral Hepat* 1995;2:39-45. ([Abstract](#))
- Wu JC, Chen CL, Hou MC, et al. Multiple viral infection as the most common cause of fulminant and subfulminant viral hepatitis in an area endemic for hepatitis B: application and limitations of the polymerase chain reaction. *Hepatology* 1994;19:836-40. ([Abstract](#))
- Yalcin K, Degertekin H, Yildiz F, et al. A severe hepatitis flare in an HBV-HCV coinfecting patient during combination therapy with alpha-interferon and ribavirin. *J Gastroenterol* 2003;38:796-800. ([Abstract](#))
- Yu JW, Sun LJ, Zhao YH, Kang P, et al. Analysis of the efficacy of treatment with peginterferon ?-2a and ribavirin in patients coinfecting with hepatitis B virus and hepatitis C virus. *Liver Int* 2009;29:1485-93. ([Abstract](#))
- Zarski JP, Bohn B, Bastie A, et al. Characteristics of patients with dual infection by hepatitis B and C viruses. *J Hepatol* 1998;28:27-33. ([Abstract](#))
- Zhou J, Dore GJ, Zhang F, et al. Hepatitis B and C virus coinfection in The TREAT Asia HIV Observational Database. *J Gastroenterol Hepatol* 2007;22:1510-8. ([Abstract](#))

## 20. Assessment of Hepatic Fibrosis in Chronic Viral Hepatitis

*Frank Grünhage and Frank Lammert*

### Introduction

Non-invasive methods for the assessment of liver fibrosis are increasingly being used versus invasive liver biopsy thanks to patient acceptance and the low but ever-present morbidity of biopsies. Non-invasive tests should be able to discriminate between non-significant (stages F0-F1) and significant (stages  $\geq$ F2) fibrosis to help either delay or initiate antiviral treatment. In addition, non-invasive markers should be able to reliably predict liver cirrhosis in order to initiate further diagnostics to exclude portal hypertension and to initiate surveillance strategies with progressive fibrosis. Non-invasive strategies are also warranted for monitoring the disease while on therapy and ideally document a regression of fibrosis in the long term.

Yet, despite recent advances in the use of surrogate markers and the development of new technical developments such as elastography, liver histology remains the gold standard for fibrosis staging (Goodman 2007). Currently an intense debate regarding non-invasive tests is going on and a number of participants of this discussion have suggested to not accept the claim of liver histology as the gold standard and define the role of histology as the best available standard (Bedossa 2009). Nevertheless, until today most experts agree that non-invasive techniques will not replace liver biopsies completely although they will help reduce the number of biopsies required (Leroy 2007, Pinzani 2005, Sebastiani 2006). While non-invasive fibrosis tests are suitable for the diagnosis of liver cirrhosis, they have been questioned for clinical practice as they lack the potential to discriminate the stages of fibrosis. This specific dogma is now being questioned, and entirely non-invasive algorithms have been developed that include a differentiation of the stages of fibrosis (Boursier 2011a, Boursier 2011b).

## Mechanisms of liver fibrosis in chronic viral hepatitis

Liver fibrosis is characterised by the loss of hepatocytes, destruction of hepatic (micro)architecture, proliferation of hepatic (myo)fibroblasts, and excess deposition of extracellular matrix components (Friedman 2008). Endstage liver fibrosis (cirrhosis) may include insufficient detoxification, hepatocellular carcinoma, portal hypertension, renal and pulmonary failure, and is associated with excess mortality. In chronic viral hepatitis, fibrosis develops as a consequence of the host immunological response. This immunological response activates antiviral defence mechanisms that aim to clear infected hepatocytes. The mechanisms underlying fibrogenesis in HBV or HCV are complex (Friedman 2007).

A key feature of hepatic fibrosis is the activation and proliferation of hepatic stellate cells. Quiescent hepatic stellate cells store vitamin A and reside in the subendothelial space of Disse. Chronic liver injury leads to activation of these cells, which become contractile, produce extracellular matrix components and secrete pro-inflammatory cytokines and chemokines like transforming growth factor  $\beta$ . The activation of these cells is believed to represent the key event in hepatic fibrogenesis (Friedman 2008). Hepatic stellate cell activation depends on signalling by Kupffer cells, endothelial cells, hepatocytes, and platelets. The deposition of the extracellular matrix is constantly opposed by degradation of these proteins. In progressive liver fibrosis, this balance is skewed in favour of excess extracellular matrix deposition. Matrix metalloproteinases and their regulators (tissue inhibitors of metalloproteinases, TIMPs) control matrix deposition and degradation. In liver fibrogenesis, TIMP-1 is also produced by activated hepatic stellate cells.

Liver histology, by helping visualise the fibrosis, has been considered the gold standard for assessment and measurement of progression of fibrosis. However, the disadvantages of this method have motivated researchers and clinicians to look into more non-invasive strategies. These strategies are based either on single serum surrogate markers, compositional scores derived from combinations of different surrogate markers, or modifications of imaging techniques.

## Liver biopsy – the gold standard for staging of liver fibrosis

In the majority of liver centres worldwide, liver biopsy is performed as a “blind” or ultrasound-guided puncture, as either an out- or in-patient procedure. Liver punctures are considered to be relatively safe procedures with complication rates ranging from 0.75% up to 13.6% (Myers 2008, Piccinino 1986, van der Poorten 2006). The most frequent complications are minor bleeding or pain. After efficient substitution with clotting factors, percutaneous liver biopsy is also possible in patients with inherited bleeding disorders with no obvious increase of complication rates (DiMichele 2003, Schwarz 2008). Procedure-related mortality rates are reported to range from 0.001 to 0.003% (Piccinino 1986). Of note, excess rates with severe bleedings and biopsy related deaths have been reported after percutaneous biopsy in populations with advanced fibrosis, cirrhosis, or hepatic tumors (Terjung 2003). Thus, liver biopsies in these patients should always be performed as in-

patient procedures, since >90% of complications are detected within the first 24 hours (Piccinino 1986).

Transjugular puncture of the liver via cannulation of a hepatic vein is an alternative, which can be performed in patients with severe coagulation deficiencies. It is resource intensive and carries a risk of intrahepatic hemorrhage or capsule perforation with intraabdominal bleeding. Complication rates are lower as compared to percutaneous biopsies and range from 2.5% (Mammen 2008) to 6.5% with a reported mortality rate of up to 0.09% in high-risk groups (Kalambokis 2007). However, the quality of specimens from transjugular biopsies may be lower because of the higher fragmentation of specimens and the lower numbers of portal fields in transjugular biopsies (Cholongitas 2006).

Laparoscopy and mini-laparoscopy are even more invasive procedures for obtaining liver biopsies. A recent randomized trial showed a higher detection rate of liver cirrhosis as compared to percutaneous biopsies with lower complication rates for laparoscopy (Denzer 2007). No data is available for detection of lesser fibrosis stages. Thus, we recommend this procedure only in selected cases if the results will have an impact on the clinical management of the patient (Helmreich-Becker 2003).

The quality and reliability of fibrosis staging via histopathological assessment of liver biopsy specimens depends largely on the size of the specimen and the number of portal fields. The biopsy should be 20-25 mm long and more than 11 portal tracts should be visible (Bedossa 2003, Cholongitas 2006, Rousselet 2005). However, in daily practice these requirements may not be easy to achieve; and even if a large enough biopsy is acquired, the specimen only reflects about 1/50,000 of the whole liver. Thus, liver biopsies are particularly prone to sampling errors and may – like non-invasive markers – have difficulties in discriminating between adjacent stages of fibrosis (i.e., F1 vs. F2 or F2 vs. F3). Recent studies report up to one stage difference between specimens from the right and the left lobe in up to 38% of biopsies (Regev 2002, Siddique 2003). Discrepancies of more than one stage are rare (Regev 2002, Siddique 2003, Skripenova 2007). Intra- and inter-observer variability may be unaffected by specimen sizes but can lead to discrepancies in up to 20% of cases, even if one stage difference between estimates is accepted (Gronbaek 2002, Petz 2003). Standardized automatic staging via image analysis may improve interobserver variability (Hui 2004, Calvaruso 2009).

All staging systems for liver fibrosis are based on the definition of categorical stages of liver fibrosis that describe the increase of deposition of collagen and the progressive destruction of liver architecture ranging from no fibrosis to cirrhosis with a variable number of intermediate stages (Table 1). The use of categories decreases interobserver variation, but also results in a loss of information that may be covered by more detailed scoring systems (Standish 2006).

Whereas the METAVIR score is considered best in HCV fibrosis, there is a wide variability in the use of other staging systems in patients with chronic viral hepatitis. In Germany, current guidelines recommend the staging system defined by Desmet & Scheuer (Table 1) (Batts 1995, Desmet 1994, Ishak 1995, Knodell 1981, Schirmacher 2004, French Cooperative Study Group 1994).



**Table 1. Commonly used liver fibrosis staging scores.**

Staging System	Fibrosis stages	Remark
METAVIR Score	F0, F1, F2, F3, F4	Best evaluated in HCV fibrosis (The French METAVIR Cooperative Study Group 1994)
Knodell Score	F0, F1, F3, F4	No intermediate stage (Knodell 1981)
Desmet & Scheuer	Analogous to METAVIR	Recommended by German guidelines for the assessment of liver fibrosis (Desmet 1994, Schirmacher 2004)
Batts & Ludwig	Similar to METAVIR	(Batts 1995)
Ishak Score	F0, F1, F2, F3, F4, F5, F6	(Ishak 1995)

## Surrogate markers of liver fibrosis in chronic viral hepatitis

Liver fibrosis develops as a continuous process rather than in a stepwise manner. Thus, so-called surrogate markers, which are also continuous variables, may provide more precise information. Surrogate markers can be subdivided into direct and indirect markers. Direct markers reflect changes in the content of extracellular matrix proteins (such as collagen) in the liver. In contrast, indirect markers reflect alterations in hepatic function, increase in portal hypertension with subsequent splenic enlargement, and/or grade of hepatic inflammation that may correlate with liver fibrosis stage (Table 2) (see <http://hepatologytextbook.com/link.php?id=7>). Direct and indirect markers may be used alone or - more commonly - in combination ("composite scores"). The calculation of such scores can be simple or based on complicated formulas (e.g., Fibrotest/Fibrosure) (Table 2). Most studies of non-invasive markers were performed in HCV patients, while studies in HBV or coinfecting cohorts are sparse (Pinzani 2008). Primary endpoints of the studies that evaluated surrogate markers vary from discrimination of no fibrosis and cirrhosis to the determination of fibrosis stages. However, for the clinical management of patients with chronic viral hepatitis both are needed. Whereas the former is needed to identify patients in need of urgent treatment, the latter may separate those patients with an indication for antiviral treatment due to significant fibrosis from those with no or minor fibrosis in whom treatment may be postponed.

From the whole range of surrogate markers only a few are in clinical use. The simple APRI score has been widely studied in HCV and HBV as well as in coinfecting patients (Cacoub 2008, Lebensztejn 2005, Vallet-Pichard 2008, Wai 2006). A recent comprehensive meta-analysis of the performance of the APRI test showed that its major strength is the exclusion of significant fibrosis, defined as F2-F4, or cirrhosis with cut-offs of 0.5 and 1.0, respectively. However, the authors conclude that using this marker alone, only about one third of all biopsies can be avoided. Importantly, the test performance varied with the quantity of advanced fibrosis in the different patient groups (Shaheen 2007, Shaheen 2008). Fibrotest has also achieved some clinical significance. However, this test may not be available for all patients. Recent meta-analyses of the predictive performance of Fibrotest

summarize that the reliability for the detection of advanced fibrosis or cirrhosis is adequate for clinical practice, and a cut-off of 0.6 has been suggested (Poynard 2007, Shaheen 2008, Shaheen 2007). Of note, the reliability for the detection of earlier fibrosis stages appears to be relatively low (Poynard 2007, Shaheen 2008). In summary, surrogate markers may support the clinical decision making process, but a single surrogate marker or score cannot replace the liver biopsy. On the other hand, attempts have been made to combine different surrogate markers and biopsy in clinical decision algorithms that aim to reduce the need for liver punctures (Table 2). Increasingly efforts are made to combine surrogate markers with transient elastography, and it seems that some progress can be expected in precise prediction of different fibrosis stages, which may eventually replace liver biopsy for fibrosis staging.

## Transient elastography

Transient elastography (TE) is a non-invasive technique to assess liver fibrosis (Sandrin 1999). TE allows the assessment of liver fibrosis by calculating the velocity of a low-frequency transient shear wave produced by a mechanical probe that is placed directly on the skin of the patient. The velocity of the wave that penetrates the liver tissue depends on the actual stiffness of the liver, which in turn correlates with the extent of liver fibrosis. In practice, a probe is placed in an intercostal space at a position that is comparable to the position for standard liver biopsy. Ten successful measurements are usually necessary for the assessment of liver stiffness. This can be done in less than 5 minutes. At present TE machines are exclusively available from Echosense (FibroScan<sup>®</sup>). Liver stiffness is expressed in kilo Pascal (kPa). The method is easy to learn, quick, results are available immediately, and a technical assistant can perform the procedure. TE displays robust intra- and inter-observer variability (Fraquelli 2007) and may be applied in children and adults (de Ledinghen 2007). Recently a special S probe for testing children and patients with small intercostals spaces was introduced, and normal reference values for different ages were defined (Engelmann 2011).

Evaluation of liver stiffness in subjects without apparent liver disease shows that liver stiffness is influenced by gender and body mass index (BMI). In general, liver stiffness is higher in men than in women ( $5.81 \pm 1.54$  vs.  $5.23 \pm 1.59$  kPa) (Roulot 2008). Interestingly, TE may be used as a screening tool for the general population to identify patients with unrecognized liver disease (Roulot 2011).

It is important to note that the applicability of TE is limited to relatively lean patients ( $BMI < 28 \text{ kg/m}^2$ ), patients without ascites, and “cooperative” patients. A special probe for obese patients has recently broadened the applicability of TE and is recommended for patients with a skin-capsular distance of  $> 2.5$  cm but below 3.5 cm (Myers 2011). In addition, TE is hampered in those with acute liver injury such as acute viral or alcoholic hepatitis, or chronic viral hepatitis flares, which may lead to an overestimation of liver fibrosis (Arena 2008, Coco 2007, Sagir 2008). Unlike liver histology, no published data is available on the variability (“sampling error”) of TE results. TE correlates well with other surrogate markers of liver fibrosis such as APRI and FIB-4 (Vidovic 2010). In patients with chronic liver disease eligible for TE, liver stiffness values correlate well with the stage of fibrosis, irrespective of the underlying disease etiology. TE has been evaluated in patients with chronic viral

hepatitis, PBC, PSC, and NASH. Due to high acceptance by patients, it can easily be used to monitor progression or regression of fibrosis in patients under observation or on therapy (Wilson 2006, Wong 2011). TE has been evaluated for the detection of liver fibrosis in patients with acute and chronic viral hepatitis and has also been positively evaluated for HIV/HCV-coinfected patients and in patients with HCV recurrence post-transplantation (Carrion 2006, de Ledinghen 2006, Maida 2007). In chronic viral hepatitis, it is unknown whether there is a difference in TE results between patients with chronic HBV, HCV, and/or HIV/HCV-coinfected patients.

In some clinical situations, e.g., older patients or patients with risk factors for therapy, a positive decision for treatment of chronic hepatitis B and C is guided by the diagnosis of significant fibrosis. The presence of F2 fibrosis indicates significant liver fibrosis, which justifies treatment according to treatment guidelines for chronic hepatitis B, C and coinfecting patients (Sarrazin 2010).

Recent studies comparing TE with liver biopsy demonstrate both high sensitivity and specificity for the detection of advanced fibrosis and cirrhosis. However, TE performance is less reliable for the detection of fibrosis stages  $\geq 2$  as compared to more advanced stages of liver fibrosis (sensitivity 56-67%), resulting in moderate negative predictive values. Thus, assessment of liver fibrosis by TE alone may result in the underestimation of liver fibrosis in some patients. Vice versa, if TE predicts significant fibrosis, a biopsy will not be necessary. One drawback in clinical practice is that the different TE studies suggest slightly different cut-off values (Table 3). A recent meta-analysis that evaluated the predictive performance of TE in patients with chronic liver disease suggested that the optimal cut-off value for the diagnosis of significant fibrosis is 7.65 kPa and 13.01 kPa for cirrhosis (Friedrich-Rust 2008). This cut-off proved to be robust, especially in patients with chronic HCV infection.

In addition to the assessment of liver fibrosis stages, TE may also be used to predict the presence of portal hypertension and thus the need to evaluate the patient for the presence of esophageal varices (Rockey 2008). Whether TE is reliable enough to predict the stage of cirrhosis is still debatable and needs further studies (Foucher 2006).

Increasing knowledge from studies on transient elastography also revealed a number of conditions that may produce false positive results the user should be aware of. These conditions include acute and chronic cardiac failure, valsalva maneuver, hepatitis flare, pulmonary hypertension, amyloidosis, cholestasis, pregnancy and steatosis, with the latter being more relevant for HCV than for HBV-infected patients (Fraquelli 2007, Arena 2008).

Another relevant artifact is the examination of a patient within 2 hours after a meal, which may increase resistance by up to 2 kPa (Mederacke 2009).

The spectrum of interpretation of elevated TE results has been broadened recently. For instance, a cut-off value of  $>25$  kPa has been associated with  $>45$ -fold increased risk to develop HCC in viral hepatitis. However, the risk seems to increase in a linear fashion starting from a cut-off of 10 kPa (Fung 2011, Masuzaki 2009). Furthermore, TE values  $>21.1$  are associated with portal hypertension as well as the risk of portal hypertension-related complications and suggest endoscopy to confirm or exclude esophageal varices and to initiate or decline the need for primary prophylaxis with propranolol (Castera 2011, Robic 2011).

**Table 3. Cut-off values for transient elastography in different study populations.**

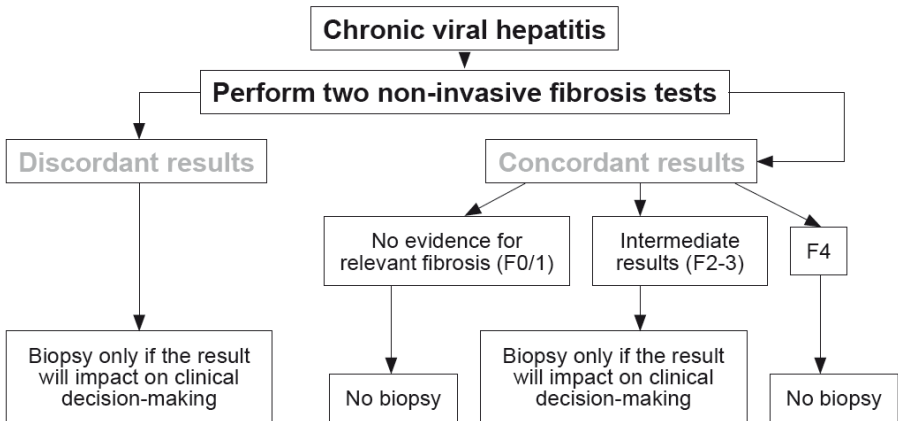
Study	Population	Cut off (kPa)				
		F=0	F≥1	F≥2	F≥3	F=4
Castera	HCV N=183	n.d.	n.d.	7.1	9.5	12.5
				Se: 0.67	Se: 0.73	Se: 0.87
				Sp: 0.95	Sp: 0.91	Sp: 0.91
				PPV: 0.95	PPV: 0.87	PPV: 0.77
				NPV: 0.48	NPV: 0.81	NPV: 0.97
Ziol	HCV N=327	n.d.	n.d.	8.8	9.6	14.6
				Se: 0.56	Se: 0.86	Se: 0.86
				Sp: 0.91	Sp: 0.85	Sp: 0.96
				PPV: 0.88	PPV: 0.71	PPV: 0.78
				NPV: 0.56	NPV: 0.93	NPV: 0.97
Foucher	HCV / HBV N=711	n.d.	n.d.	7.2	12.5	17.6
				Se: 0.64	Se: 0.65	Se: 0.77
				Sp: 0.85	Sp: 0.95	Sp: 0.97
				PPV: 0.90	PPV: 0.90	PPV: 0.91
				NPV: 0.52	NPV: 0.80	NPV: 0.92
Ogawa	HCV / HBV N=229	3.5	6.4	9.5	11.4	15.4
				Se: 0.67	Se: 0.67	Se: 0.67
				Sp: 0.95	Sp: 0.95	Sp: 0.95
				PPV: .95	PPV: .95	PPV: .95
				NPV: .48	NPV: .48	NPV: .48
		6.3	6.7	9.1	13.7	26.4
				Se: 0.67	Se: 0.67	Se: 0.67
				Sp: 0.95	Sp: 0.95	Sp: 0.95
				PPV: 0.95	PPV: 0.95	PPV: 0.95
				NPV: 0.48	NPV: 0.48	NPV: 0.48
Arena	HCV N=150			7.8	10.8	14.8
				Se: 0.83	Se: 0.91	Se: 0.94
				Sp: 0.82	Sp: 0.94	Sp: 0.92
				PPV: 0.83	PPV: 0.89	PPV: 0.73
				NPV: 0.79	NPV: 0.95	NPV: 0.98
De Ledinghen	HIV/HCV N=72	n.d.	n.d.	4.5	n.d.	11.8
				Se: 0.93		Se: 1.0
				Sp: 0.18		Sp: 0.93
				PPV: n.d.		PPV: n.d.
				NPV: n.d.		NPV: n.d.

## Other imaging techniques for the assessment of liver fibrosis

A number of different imaging techniques such as conventional ultrasound, real-time elastography, acoustic radiation force imaging (ARFI), portal venous transit time, NMR imaging and CT have been used for the assessment of liver fibrosis. None of these methods has yet achieved an overall clinical acceptance regarding the detection of early liver fibrosis, either due to low sensitivity and/or specificity, or high costs. The most promising candidate for everyday usability may be the ARFI technique that has been integrated in high-end ultrasound machines. This technique allows the measurement of liver fibrosis in an area of interest rather than a global assessment as with the transient elastography method. This may be an advantage as different regions of the liver may be studied separately but may – like histology – also be a source of “sampling bias” and low reproducibility. Compared to transient elastography the available data from large populations is sparse. A recent meta-analysis managed to combine data from 518 individuals. Nevertheless, in this analysis the overall accuracy for the prediction of fibrosis stage  $\geq F2$ ,  $\geq F3$  and cirrhosis as determined by ROC analysis were 0.87, 0.91, 0.93, respectively (Friedrich-Rust 2012).

## Clinical decision algorithms

Until now, no non-invasive marker for the staging of liver fibrosis has been able to replace the liver histology as the gold standard. This is largely due to the fact that outcome studies with clear endpoints like mortality have not been performed and that a clear differentiation of fibrosis stage by non-invasive strategies has been unreliable. But the advantages of these non-invasive tests in comparison to liver biopsy are striking. In order to overcome test limitations and to benefit from their specific advantages, a frequent strategy is to combine different noninvasive tests, thereby using liver biopsy only in case of doubt. However, former algorithms vary greatly in performance and acceptance. Whereas some authors have calculated a reduction in liver biopsies of 30%, others have estimated reductions of up to 80% (Leroy 2007, Sebastiani 2004, Sebastiani 2006, Sebastiani 2007). New strategies with sophisticated algorithms may overcome all these limitations and combination of TE with FibroMeter achieved results that may give detailed and reliable information on liver fibrosis stage without any need for histology. However, only one study from France has described this method, which needs to be cross-validated by independent groups (Boursier 2011a, Boursier 2011b).



**Figure 1. Potential clinical decision algorithm for safer liver biopsies in patients with chronic viral hepatitis.**

## Summary

Non-invasive tests have not replaced liver biopsies today, but smart combinations of non-invasive tools can save many patients from the more invasive procedure. Whatever the current standard of care, the patient should be informed about the non-invasive tests, their applicability and their limitations. The decision to biopsy should ultimately be made together with the informed patient.

## References

- Arena U. Acute viral hepatitis increases liver stiffness values measured by transient elastography. *Hepatology* 2008;47:380-4.
- Batts KP, Ludwig J. Chronic hepatitis. An update on terminology and reporting. *Am J Surg Pathol* 1995;19:1409-17. ([Abstract](#))
- Bedossa P, Carrat F. Liver biopsy: the best, not the gold standard. *J Hepatol* 2009;50:1-3. ([Abstract](#))
- Bedossa P, Dargere D, Paradis V. Sampling variability of liver fibrosis in chronic hepatitis C. *Hepatology* 2003;38:1449-57. ([Abstract](#))
- Boursier J, de Ledinghen V, Zarski JP, Fouchard-Hubert I, Gallois Y, Oberti F, Cales P. Comparison of 8 diagnostic algorithms for liver fibrosis in hepatitis C: New algorithms are more precise and entirely non-invasive. *Hepatology* 2011a. Epub ahead of print.
- Boursier J, de Ledinghen V, Zarski JP, Rousselet MC, Sturm N, Foucher J, et al. A new combination of blood test and fibroscan for accurate non-invasive diagnosis of liver fibrosis stages in chronic hepatitis C. *Am J Gastroenterol* 2011b;106:1255-63. ([Abstract](#))
- Cacoub P, Carrat F, Bedossa P, Lambert J, Penaranda G, Perronne C, et al. Comparison of non-invasive liver fibrosis biomarkers in HIV/HCV co-infected patients: The fibrovisc study - ANRS HC02. *J Hepatol* 2008;48:765-73. ([Abstract](#))
- Calvaruso V, Burroughs AK, Standish R, Manousou P, Grillo F, Leandro G, et al. Computer-assisted image analysis of liver collagen: relationship to Ishak scoring and hepatic venous pressure gradient. *Hepatology* 2009;49:1236-44. ([Abstract](#))
- Carrion JA, Navasa M, Bosch J, Bruguera M, Gilabert R, Forns X. Transient elastography for diagnosis of advanced fibrosis and portal hypertension in patients with hepatitis C recurrence after liver transplantation. *Liver Transpl* 2006;12:1791-8. ([Abstract](#))

- Castera L, Pinzani M, Bosch J. Non Invasive Evaluation of Portal Hypertension Using Transient Elastography. *J Hepatol* 2011. Epub ahead of print. ([Abstract](#))
- Cholongitas E, Senzolo M, Standish R, Marelli L, Quaglia A, Patch D, et al. A systematic review of the quality of liver biopsy specimens. *Am J Clin Pathol* 2006;125:710-21. ([Abstract](#))
- Coco B, Oliveri F, Maina AM, Ciccorossi P, Sacco R, Colombatto P, et al. Transient elastography: a new surrogate marker of liver fibrosis influenced by major changes of transaminases. *J Viral Hepat* 2007;14:360-9. ([Abstract](#))
- de Ledington V. Diagnosis of hepatic fibrosis and cirrhosis by transient elastography in HIV/hepatitis C virus co-infected patients. *J Acquir Immune Defic Syndr* 2006;41:175-9. ([Abstract](#))
- de Ledington V, Le Bail B, Rebouissoux L, Fournier C, Foucher J, Miette V, et al. Liver stiffness measurement in children using FibroScan: feasibility study and comparison with Fibrotest, aspartate transaminase to platelets ratio index, and liver biopsy. *J Pediatr Gastroenterol Nutr* 2007;45:443-50. ([Abstract](#))
- Denzer U, Arnoldy A, Kanzler S, Galle PR, Dienes HP, Lohse AW. Prospective randomized comparison of minilaparoscopy and percutaneous liver biopsy: diagnosis of cirrhosis and complications. *J Clin Gastroenterol* 2007;41:103-10. ([Abstract](#))
- Desmet VJ, Gerber M, Hoofnagle JH, Manns M, Scheuer PJ. Classification of chronic hepatitis: diagnosis, grading and staging. *Hepatology* 1994;19:1513-20. ([Abstract](#))
- DiMichele DM, Mirani G, Wilfredo Canchis P, Trost DW, Talal AH. Transjugular liver biopsy is safe and diagnostic for patients with congenital bleeding disorders and hepatitis C infection. *Haemophilia* 2003;9:613-8. ([Abstract](#))
- Engelmann G, Gebhardt C, Wenning D, Wuhl E, Hoffmann GF, Selmi B, et al. Feasibility study and control values of transient elastography in healthy children. *Eur J Pediatr* 2011. ([Abstract](#))
- Foucher J, Chanteloup E, Vergniol J, Castera L, Le Bail B, Adhoute X, et al. Diagnosis of cirrhosis by transient elastography (FibroScan): a prospective study. *Gut* 2006;55:403-8. ([Abstract](#))
- Fraquelli M, Rigamonti C, Casazza G, Conte D, Donato MF, Ronchi G, Colombo M. Reproducibility of transient elastography in the evaluation of liver fibrosis in patients with chronic liver disease. *Gut* 2007;56:968-73. ([Abstract](#))
- Fraquelli M, Rigamonti C, Casazza G, Donato MF, Ronchi G, Conte D, et al. Etiology-related determinants of liver stiffness values in chronic viral hepatitis B or C. *J Hepatol* 2011;54:621-8. ([Abstract](#))
- Friedman SL. Hepatic stellate cells: protean, multifunctional, and enigmatic cells of the liver. *Physiol Rev* 2008;88:125-72. ([Abstract](#))
- Friedman SL, Rockey DC, Bissell DM. Hepatic fibrosis 2006: report of the Third AASLD Single Topic Conference. *Hepatology* 2007;45:242-9. ([Abstract](#))
- Friedrich-Rust M, Nierhoff J, Lupsor M, Sporea I, Fierbinteanu-Braticevici C, Strobel D, et al. Performance of Acoustic Radiation Force Impulse imaging for the staging of liver fibrosis: a pooled meta-analysis. *J Viral Hepat* 2012;19:e212-e9. ([Abstract](#))
- Friedrich-Rust M, Ong MF, Martens S, Sarrazin C, Bojunga J, Zeuzem S, Herrmann E. Performance of transient elastography for the staging of liver fibrosis: a meta-analysis. *Gastroenterology* 2008;134:960-74. ([Abstract](#))
- Fung J, Lai CL, Seto WK, Wong DK, Yuen MF. Prognostic significance of liver stiffness for hepatocellular carcinoma and mortality in HBeAg-negative chronic hepatitis B. *J Viral Hepat* 2011;18:738-44. ([Abstract](#))
- Goodman ZD. Grading and staging systems for inflammation and fibrosis in chronic liver diseases. *J Hepatol* 2007;47:598-607. ([Abstract](#))
- Gronbaek K, Christensen PB, Hamilton-Dutoit S, Federspiel BH, Hage E, Jensen OJ, Vyberg M. Interobserver variation in interpretation of serial liver biopsies from patients with chronic hepatitis C. *J Viral Hepat* 2002;9:443-9. ([Abstract](#))
- Helmreich-Becker I, Schirmacher P, Denzer U, Hensel A, Meyer zum Buschenfelde KH, Lohse AW. Minilaparoscopy in the diagnosis of cirrhosis: superiority in patients with Child-Pugh A and macronodular disease. *Endoscopy* 2003;35:55-60. ([Abstract](#))
- Hui AY, Liew CT, Go MY, Chim AM, Chan HL, Leung NW, Sung JJ. Quantitative assessment of fibrosis in liver biopsies from patients with chronic hepatitis B. *Liver Int* 2004;24:611-8. ([Abstract](#))
- Ishak K, Baptista A, Bianchi L, Callea F, De Groote J, Gudat F., et al. Histological grading and staging of chronic hepatitis. *J Hepatol* 1995;22:696-9. ([Abstract](#))

- Kalambokis G, Manousou P, Vibhakorn S, Marelli L, Cholongitas E, Senzolo M, et al. Transjugular liver biopsy--indications, adequacy, quality of specimens, and complications--a systematic review. *J Hepatol* 2007;47:284-94. (Abstract)
- Knodell RG, Ishak KG, Black WC, Chen TS, Craig R, Kaplowitz N, et al. Formulation and application of a numerical scoring system for assessing histological activity in asymptomatic chronic active hepatitis. *Hepatology* 1981;1:431-5.
- Lebensztejn DM, Skiba E, Sobaniec-Lotowska M, Kaczmarek M. A simple noninvasive index (APRI) predicts advanced liver fibrosis in children with chronic hepatitis B. *Hepatology* 2005;41:1434-5. (Abstract)
- Leroy V. Prospective comparison of six non-invasive scores for the diagnosis of liver fibrosis in chronic hepatitis C. *J Hepatol* 2007;46:775-82. (Abstract)
- Maida I, Soriano V, Barreiro P, Rivas P, Labarga P, Nunez M. Liver fibrosis stage and HCV genotype distribution in HIV-HCV coinfecting patients with persistently normal transaminases. *AIDS Res Hum Retroviruses* 2007;23:801-4. (Abstract)
- Mammen T, Keshava SN, Eapen CE, Raghuram L, Moses V, Gopi K, et al. Transjugular liver biopsy: a retrospective analysis of 601 cases. *J Vasc Interv Radiol* 2008;19:351-8. (Abstract)
- Masuzaki R, Tateishi R, Yoshida H, Goto E, Sato T, Ohki T, et al. Prospective risk assessment for hepatocellular carcinoma development in patients with chronic hepatitis C by transient elastography. *Hepatology* 2009;49:1954-61. (Abstract)
- Mederacke I, Wursthorn K, Kirschner J, Rifai K, Manns MP, Wedemeyer H, Bahr MJ. Food intake increases liver stiffness in patients with chronic or resolved hepatitis C virus infection. *Liver Int* 2009;29:1500-6. (Abstract)
- Myers RP, Fong A, Shaheen AA. Utilization rates, complications and costs of percutaneous liver biopsy: a population-based study including 4275 biopsies. *Liver Int* 2008;28:705-12. (Abstract)
- Myers RP, Pomier-Layrargues G, Kirsch R, Pollett A, Duarte-Rojo A, Wong D, Beaton M, Levstik M, Crotty P, Elkashab M. Feasibility and diagnostic performance of the fibroscan xl probe for liver stiffness measurement in overweight and obese patients. *Hepatology* 2011. Epub ahead of print.
- Petz D, Klauck S, Rohl FW, Malfertheiner P, Roessner A, Rocken C. Feasibility of histological grading and staging of chronic viral hepatitis using specimens obtained by thin-needle biopsy. *Virchows Arch* 2003;442:238-44. (Abstract)
- Piccinino F, Sagnelli E, Pasquale G, Giusti G. Complications following percutaneous liver biopsy. A multicentre retrospective study on 68,276 biopsies. *J Hepatol* 1986;2:165-73. (Abstract)
- Pinzani M. Fibrosis in chronic liver diseases: diagnosis and management. *J Hepatol* 2005;42:S22-36. (Abstract)
- Pinzani M, Vizzutti F, Arena U, Marra F. Technology Insight: noninvasive assessment of liver fibrosis by biochemical scores and elastography. *Nat Clin Pract Gastroenterol Hepatol* 2008;5:95-106. (Abstract)
- Poynard T, Morra R, Halfon P, Castera L, Ratziu V, Imbert-Bismut F, et al. Meta-analyses of FibroTest diagnostic value in chronic liver disease. *BMC Gastroenterol* 2007;7:40. (Abstract)
- Regev A, Berho M, Jeffers LJ, Milikowski C, Molina EG, Pyrsopoulos NT, et al. Sampling error and intraobserver variation in liver biopsy in patients with chronic HCV infection. *Am J Gastroenterol* 2002;97:2614-8. (Abstract)
- Robic MA, Procopet B, Metivier S, Peron JM, Selves J, Vinel JP, Bureau C. Liver stiffness accurately predicts portal hypertension related complications in patients with chronic liver disease: A prospective study. *J Hepatol* 2011. (Abstract)
- Rockey DC. Noninvasive assessment of liver fibrosis and portal hypertension with transient elastography. *Gastroenterology* 2008;134:8-14. (Abstract)
- Roulot D, Costes JL, Buyck JF, Warzocha U, Gambier N, Czernichow S, et al. Transient elastography as a screening tool for liver fibrosis and cirrhosis in a community-based population aged over 45 years. *Gut* 2011;60:977-84. (Abstract)
- Roulot D, Czernichow S, Le Clesiau H, Costes JL, Vergnaud AC, Beaugrand M. Liver stiffness values in apparently healthy subjects: Influence of gender and metabolic syndrome. *J Hepatol* 2008;48:606-13. (Abstract)
- Rousselet MC, Michalak S, Dupre F, Croue A, Bedossa P, Saint-Andre JP, Cales P. Sources of variability in histological scoring of chronic viral hepatitis. *Hepatology* 2005;41:257-64. (Abstract)



- Sagir A, Erhardt A, Schmitt M, Haussinger D. Transient elastography is unreliable for detection of cirrhosis in patients with acute liver damage. *Hepatology* 2008;47:592-5. (Abstract)
- Sandrin L, Catheline S, Tanter M, Hennequin X, Fink M. Time-resolved pulsed elastography with ultrafast ultrasonic imaging. *Ultrason Imaging* 1999;21:259-72. (Abstract)
- Sarrazin C, Berg T, Ross RS, Schirmacher P, Wedemeyer H, Neumann U, et al. [Prophylaxis, diagnosis and therapy of hepatitis C virus (HCV) infection: the German guidelines on the management of HCV infection]. *Z Gastroenterol*;48:289-351. (Abstract)
- Schirmacher P, Fleig WE, Dienes HP. [Biopsy diagnosis of chronic hepatitis]. *Z Gastroenterol* 2004;42:175-85. (Abstract)
- Schwarz KB, Zellos A, Stamato L, Boitnott J, Perlman E, Chong S, Casella JF. Percutaneous liver biopsy in hemophiliac children with chronic hepatitis C virus infection. *J Pediatr Gastroenterol Nutr* 2008;46:423-8.
- Sebastiani G. Stepwise combination of algorithms of non-invasive markers to diagnose significant fibrosis in chronic hepatitis C. *J Hepatol* 2004;44:686-93. (Abstract)
- Sebastiani G, Alberti A. Non invasive fibrosis biomarkers reduce but not substitute the need for liver biopsy. *World J Gastroenterol* 2006;12:3682-94. (Abstract)
- Sebastiani G, Vario A, Guido M, Alberti A. Sequential algorithms combining non-invasive markers and biopsy for the assessment of liver fibrosis in chronic hepatitis B. *World J Gastroenterol* 2007;13:525-31. (Abstract)
- Shaheen AA, Myers RP. Diagnostic accuracy of the aspartate aminotransferase-to-platelet ratio index for the prediction of hepatitis C-related fibrosis: a systematic review. *Hepatology* 2007;46:912-21. (Abstract)
- Shaheen AA, Myers RP. Systematic Review and Meta-Analysis of the Diagnostic Accuracy of Fibrosis Marker Panels in Patients with HIV/Hepatitis C Coinfection. *HIV Clin Trials* 2008;9:43-51. (Abstract)
- Shaheen AA, Wan AF, Myers RP. FibroTest and FibroScan for the prediction of hepatitis C-related fibrosis: a systematic review of diagnostic test accuracy. *Am J Gastroenterol* 2007;102:2589-600. (Abstract)
- Siddique I, El-Naga HA, Madda JP, Memon A, Hasan F. Sampling variability on percutaneous liver biopsy in patients with chronic hepatitis C virus infection. *Scand J Gastroenterol* 2003;38:427-32. (Abstract)
- Skripenova S, Trainer TD, Krawitt EL, Blaszyk H. Variability of grade and stage in simultaneous paired liver biopsies in patients with hepatitis C. *J Clin Pathol* 2007;60:321-4. (Abstract)
- Standish RA, Cholongitas E, Dhillon A, Burroughs AK, Dhillon AP. An appraisal of the histopathological assessment of liver fibrosis. *Gut* 2006;55:569-78. (Abstract)
- Terjung B, Lemnitzer I, Dumoulin FL, Effenberger W, Brackmann HH, Sauerbruch T, Spengler U. Bleeding complications after percutaneous liver biopsy. An analysis of risk factors. *Digestion* 2003;67:138-45. (Abstract)
- TFMCSG. Intraobserver and interobserver variations in liver biopsy interpretation in patients with chronic hepatitis C. The French METAVIR Cooperative Study Group. *Hepatology* 1994;20:15-20. (Abstract)
- Vallet-Pichard A, Mallet V, Pol S. Predictive value of FIB-4 versus fibrotest, APRI, FIBROINDEX and FORNS to noninvasively estimate fibrosis in hepatitis C. *Hepatology* 2008;47:762-3. (Abstract)
- van der Poorten D, Kwok A, Lam T, Ridley L, Jones DB, Ngu MC, Lee AU. Twenty-year audit of percutaneous liver biopsy in a major Australian teaching hospital. *Intern Med J* 2006;36:692-9. (Abstract)
- Vidovic N, Lochowsky RS, Goldmann G, Rockstroh J, Wasmuth JC, Spengler U, et al. Correlation of transient elastography with APRI and FIB-4 in a cohort of patients with congenital bleeding disorders and HCV or HIV/HCV coinfection. *Haemophilia* 2010;16:778-85. (Abstract)
- Wai CT, Cheng CL, Wee A, Dan YY, Chan E, Chua W, et al. Non-invasive models for predicting histology in patients with chronic hepatitis B. *Liver Int* 2006;26:666-72. (Abstract)
- Wilson LE, Torbenonson M, Astemborski J, Faruki H, Spoler C, Rai R, et al. Progression of liver fibrosis among injection drug users with chronic hepatitis C. *Hepatology* 2006;43:788-95. (Abstract)
- Wong GL, Wong VW, Choi PC, Chan AW, Chim AM, Yiu KK, et al. On-treatment monitoring of liver fibrosis with transient elastography in chronic hepatitis B patients. *Antivir Ther* 2011;16:165-72. (Abstract)

## 21. Diagnosis, Prognosis & Therapy of Hepatocellular Carcinoma

*Ulrich Spengler*

### Classification of HCC

Tumors are classified in order to stratify patients with respect to their survival prognosis, to select and offer optimised therapeutic options at any tumor stage. In HCC the Barcelona Clinic Liver Cancer (BCLC) Classification has been adopted as the international standard, which is recommended by both the American Association for the Study of Liver Diseases (AASLD) and the European Association for the Study of the Liver (EASL) (Table 1). The BCLC classification takes into account several aspects of the disease: the patient's general state of health, the severity of the liver disease as well as the extent of tumor spread (Llovet 1999). Patients in stages BCLC 0 and A have a considerably better prognosis than patients in advanced stages of liver cancer (Mazzaferro 1996). Nevertheless approximately only 25% of patients with liver cancer are diagnosed at an early stage. Both EASL and AASLD guidelines also provide recommendations regarding which therapy is best suited to treat patients at each stage of the BCLC classification. Unlike classification schemes in other types of malignancies, the BCLC classification is particularly helpful because it is entirely based on clinical parameters - molecular characteristics are not yet able to reliably assess individual prognosis of patients with HCC.

**Table 1. Barcelona Clinic Liver Cancer (BCLC) Classification.**

Tumor stage	General state of health	Tumor characteristics	Child stage
0 Very early	Good	Single nodule <2 cm	A & B
A Early	Good	Single nodule <5 cm, 3 nodules <3 cm	A & B
B Intermediate	Good	Large, multiple nodules	A & B
C Advanced	Reduced	Vascular invasion, extrahepatic secondaries	A & B
D Terminal	Severely reduced	Any form	C

## Epidemiology

HCC constitutes the sixth most frequent form of cancer worldwide, and it holds third place concerning malignancy-related mortality (Parkin 2005). Incidence rates of HCC are steadily rising both in Europe and the US.

Chronic hepatitis B is the major risk factor for developing HCC in Africa and Asia, while in the US, Europe and Japan chronic hepatitis C is the leading cause of HCC. Eighty percent of liver cancers are found in cirrhotic livers, which themselves carry a high risk for HCC. Chronic carriers of hepatitis B virus (HBV) have a 100-fold increased risk as compared to a non-infected healthy reference population. Recent reports from Taiwan indicate a direct link between HBV viral loads and the risk of developing liver cancer within 10 years (Chen 2006, Iloeje 2006). The risk of HCC is significantly increased once HBV viral loads exceed 2000 IU/ml irrespective of the degree of hepatic inflammation. In developing countries exposure to aflatoxins further increases this risk of HCC.

Approximately 130-170 million people are infected with the hepatitis C virus worldwide, 20 to 30% of whom will develop liver cirrhosis, which carries a 3-5% annual risk of ultimately progressing to liver cancer. In practical terms this means that approximately one third of cirrhotic patients with hepatitis C will go on to develop HCC. Unlike hepatitis B a close relationship between HCV viral loads and the risk of developing HCC apparently does not exist (Bralet 2000). As a general rule patients will not develop liver cancer in chronic hepatitis C before their disease has progressed to the stage of cirrhosis. Consumption of alcohol or tobacco enhances the risk of HCC (Donato 2002, Gelatti 2005). Beyond that, obesity (Calle 2003) and diabetes mellitus (Davila 2005) must be considered neglected but nevertheless pivotal factors that can multiply the risk of liver cancer in western countries resulting in 4 to 40-fold increased HCC rates among patients with chronic viral hepatitis. Finally a genetic polymorphism in the adiponutrin gene seems to predispose patients with alcoholic and non-alcoholic fatty liver disease to develop cirrhosis and HCC (Fallet 2011, Nischalke 2011)

## Surveillance of patients at high risk and early HCC diagnosis

Surveillance is cost effective if the expected HCC risk exceeds 1.5% per year in hepatitis C and 0.2% per year in hepatitis B. Surveillance has to be based on ultrasound examination at 6-month intervals. When 3- versus 6-month surveillance intervals were compared in a randomized study involving 1200 patients, there was no evidence that the shorter interval improved rates of early diagnosis and therapeutic outcomes. However, if patients with cirrhosis harbour nodular lesions, the 3-month control interval is preferred due to the high potential of malignancy and growth characteristics of such lesions (Yao 2006). Alpha-fetoprotein (AFP) has insufficient sensitivity and specificity, and thus is no longer recommended for HCC surveillance. The consistent use of ultrasound in patients with a high risk for HCC enables us to diagnose early carcinoma in 30% of patients who then have a reasonable chance of curative therapy.

## Diagnosis

The diagnosis of HCC can either be made by detecting malignantly transformed hepatocytes in a liver biopsy or by dynamic contrast-enhanced radiological imaging techniques demonstrating intense arterial uptake followed by wash-out of contrast in the delayed venous phases reflecting arterialed perfusion of the tumor. Contrast-enhanced ultrasound may falsely suggest HCC in some patients with cholangiocarcinoma, and it should not be used as the only diagnostic tool for HCC (Vilana 2010). Nevertheless, novel diagnostic algorithms enable the diagnosis of HCC in a cirrhotic liver without histopathology or reference to elevated tumor markers.

The distinction between a dysplastic nodule and early HCC poses a particularly challenging task for the pathologist. Staining for glypican 3, heat shock protein 70, and glutamine synthetase is advised in this situation, and positivity for any two of these three markers confirms the presence of HCC (International Working Party 2009).

Radiological diagnosis of HCC uses detection of hyper-vascularized nodular lesions. Contrast-enhanced computed tomography (CT) or nuclear magnetic spin resonance tomography (MRT) are considered to be equivalent diagnostic tools, and international consensus guidelines accept a diagnosis of HCC without histopathology if the patient with a nodular lesion in a cirrhotic liver exhibits the following sequence of events: in the arterial phase, HCC enhances more intensely than the surrounding liver, because arterial blood in the liver is diluted by venous blood from the portal venous circulation, whereas HCC contains only arterial blood. In the venous phase, HCC enhances less than the liver, reflecting the fact that HCC does not have a portal venous blood supply and that the arterial blood flowing into the lesion no longer contains contrast. This phenomenon is termed “washout”. In the delayed phase “washout” persists, and occasionally HCC can only be detected in this phase of a dynamic study. Thus, a four-phase dynamic study is needed to reliably make a diagnosis of HCC (unenhanced, arterial, venous and delayed venous phases). Contrast enhancement in the early arterial phase, which disappears in the late venous phase, is highly specific for HCC.

The current recommendations for the diagnosis of HCC are summarized in Figure 1. For lesions smaller than 1 cm detailed investigation is not recommended because most lesions will represent regenerative nodules rather than HCC. However, close follow-up in 3-month intervals should be offered using the same imaging technique that detected the lesion in the first place.

For lesions larger than 1 cm, either dynamic MRI or multidetector CT scans should be performed. If findings are characteristic for HCC as described above, a firm diagnosis of HCC can be made and no further studies are necessary. If the findings are not typical for HCC, then the alternative dynamic imaging technique should be applied. If this supplementary radiological investigation yields typical features, the diagnosis of HCC is confirmed. Otherwise, a guided biopsy of the lesion should be performed. Contrast-enhanced CT and MRI exhibit excellent diagnostic sensitivity and specificity if the rules regarding early hypervascularity and washout are strictly applied. The presence of arterial hypervascularisation alone is not sufficient for a diagnosis of HCC, which requires the presence of venous washout as an essential second diagnostic component. In equivocal situations the

diagnosis must be clarified by biopsies, which may have to be repeated within a short period of time.

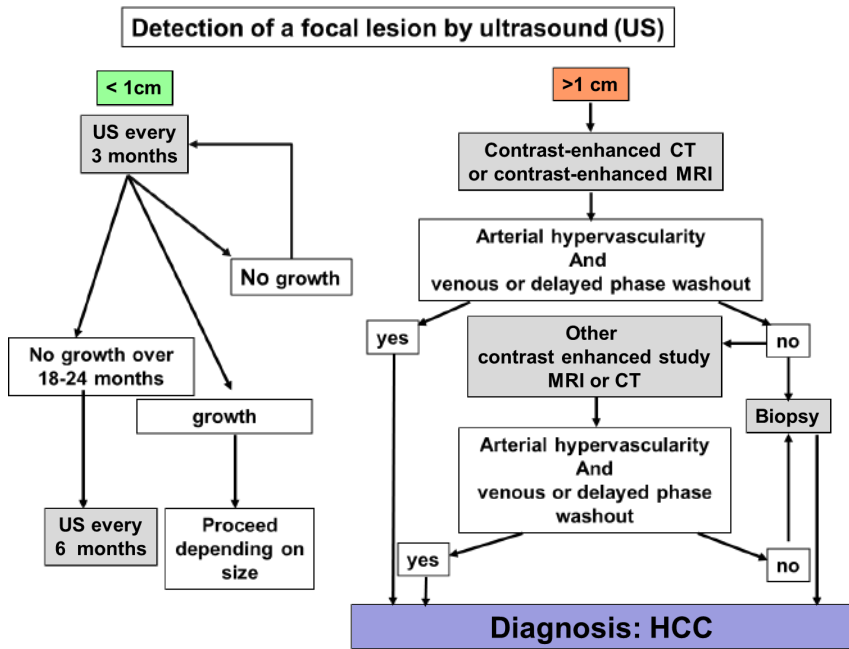


Figure 1. Diagnostic algorithm for the diagnosis of hepatocellular carcinoma depending on tumor size.

## Stage-adapted therapy for liver cancer

Patients with early HCC have excellent chances for curative cancer treatment. They can achieve 5-year survival rates of 50-70% by surgical resection, liver transplantation or percutaneous ablative procedures. With more advanced HCC, local transarterial embolisation and multikinase inhibitor therapy can still prolong life. Figure 2 gives a summary and concise overview of stage-adapted therapy for hepatocellular carcinoma.

### Potentially curative therapy in BCLC stages 0-A

**Surgical resection** constitutes the backbone of curative treatment in patients with early HCC. It is the treatment of choice in patients with localised tumor spread and small-sized cancers and tumors in a non-cirrhotic liver (evidence grade IIIA). Prognosis after surgical resection is excellent, if the tumor is not larger than 2 cm in diameter (5-year survival rates 70-90% with rates of tumor recurrence below 10%). Excluding patients with poor liver function keeps perioperative mortality below 5%. Favourable criteria for surgical resection comprise single nodules less than 5 cm in size or a maximum of 3 nodules in a single liver lobe. Patients should be carefully selected to diminish the risk of postoperative liver failure. Patients should have only moderately impaired liver function (cirrhosis stage Child’s A), should not have

portal hypertension (hepatic-portal-vein pressure gradient >10 mm Hg, presence of esophageal varices or splenomegaly together with reduced platelet counts <100,000/ $\mu$ l) and should have a serum bilirubin in the normal range. Right hepatectomy in cirrhotic patients has a higher risk of inducing hepatic decompensation than left hepatectomy.

**Liver transplantation** is an alternative therapeutic option, if the liver cancer cannot be cured by local resection due to anatomical reasons, if residual liver function after resection is anticipated to be poor, or if there is multi-nodular tumor spread into both liver lobes (evidence grade IIIA). Commonly patients with HCC are selected for liver transplant according to the so-called Milan criteria, i.e., the patient has a single nodule of less than 5 cm in diameter or at most 3 nodules, none of which exceeds 3 cm in diameter (Mazzaferro 1996). Milan criteria patients usually achieve survival rates of 80% and 70% one and five years after liver transplantation. However, it has been demonstrated that selected patients with more extensive stages of liver cancer can be transplanted with reasonable long-term outcomes (Yao 2001). Selection of patients according to the so-called San Francisco criteria comprises solitary large nodules up to 6.5 cm as well as multi-nodular HCC with a maximum of 3 nodules, each of which must be smaller than 4.5 cm with a total sum of all nodule diameters below 8 cm. Patients who remain within these extended selection criteria can still reach 70-80% five-year survival rates after liver transplantation. However, there is very limited data to support extending selection criteria for liver transplantation (Pomfret 2010).

A central issue in liver transplantation is the process of fair organ allocation. Shortage of donor organs is particularly critical in patients with liver cancer, because the tumor will continue to expand while the patient is on the waiting list, and can ultimately reach a stage that makes liver transplantation a futile option. It has been estimated that after one year on the waiting list approximately 40% of patients can no longer be cured by liver transplant (Poon 2007). In the Eurotransplant registry donor livers are allocated to patients according to their MELD scores. To circumvent the problem that patients with early HCC who are eligible for liver transplantation have rather low MELD scores, Eurotransplant accepts the diagnosis of HCC within the Milan criteria as a so-called standard exemption, allocating additional points on top of the patient's lab-MELD score in an incremental time-dependent fashion.

Most transplant centres treat liver cancers locally while the patient is on the waiting list, mostly using transarterial chemoembolisation. This strategy probably also facilitates patient selection for liver transplantation, because those with stable disease after chemoembolisation achieve a greater than 90% five-year survival rate after liver transplantation, while only 35% of patients in the group with progressive tumor expansion survive five years post-liver transplantation (Otto 2006).

**Radiofrequency ablation** can also cure HCC that is limited to a distinct region of the liver and is especially applied in older patients or patients with significant comorbidity. A cohort study on percutaneous radiofrequency ablation demonstrated that complete ablation of lesions smaller than 2 cm is possible in more than 90% of patients with local recurrence in less than 1% (Livraghi 2008). In larger tumors five-year survival rates are somewhat lower, at 70-80% for nodules less than 3 cm in diameter, and 50% for tumors between 3 and 5 cm (Lopez 2006). A cumulative

meta-analysis has suggested that survival is better after radio frequency ablation than after ethanol injection (Cho 2009).

**Adjuvant therapy**, in the context of resection, liver transplantation or local-ablative procedures, does seem to offer additional benefits. Thus far, antiviral treatment of hepatitis B with nucleos(t)ide analogs remains the single approved treatment after removal or local destruction of HCC.

**Tumor recurrence** is frequent after putatively curative treatment of HCC. The best predictors of HCC recurrence are microvascular invasion and/or additional tumor sites besides the primary lesion. There is no effective adjuvant therapy to reduce recurrence rates. However, it is noteworthy that even the most modern CT and MRT scanner still underestimate the extent of vascular invasion in 30% of patients with early HCC. Treatment of recurrence is a poorly studied area. Solitary nodules might be amenable to repeat resection, but HCC recurrence is frequently multifocal owing to intrahepatic dissemination of the tumor. Some patients with HCC recurrence after primary resection might benefit from salvage transplantation.

### **Palliative therapy in BCLC stages B and C**

Palliative treatment remains the only therapeutic option for patients with advanced stages of liver cancer that cannot be controlled by local therapy.

**Arterial chemoembolisation** is the most frequent palliative intervention offered to patients with HCC and is considered for patients with non-surgical HCC that are also not suited for percutaneous ablation and do not have extrahepatic tumor spread. HCC exhibits intense neoangiogenic activity, so that even well-differentiated HCCs become highly dependent on arterial blood supply. Thus, hepatic arterial obstruction is performed either by angiographic transarterial embolisation or transarterial chemoembolisation. Usually lipiodol combined with an embolising agent such as gelatin or microspheres is mixed with cytostatic drugs and applied to the liver via an intra-arterial catheter. Suitable cytotoxic agents are doxorubicin, mitomycin and cis-platinum, but the optimal combination of drugs and treatment schedules has not been established. In randomised studies demonstrating a benefit of chemoembolisation, doxorubicin or cis-platinum were administered in 3-4 angiographic sessions per year. Chemoembolisation carries the risk of ischemic damage to the liver, potentially leading to fulminant liver failure. To minimize this risk chemoembolisation should be offered only to patients with good residual hepatic function, who have asymptomatic multi-nodular liver cancer without vascular invasion or extrahepatic tumor spread. Vice versa patients with decompensated liver disease (liver cirrhosis, Child's B or C) or imminent hepatic failure should not undergo chemoembolisation. The side effects of interarterial chemoembolisation are the same as for systemic chemotherapy and comprise nausea, vomiting, bone marrow depression, alopecia and renal damage. As a complication of hepatic ischemia, more than 50% of patients also develop a so-called post-embolisation syndrome with fever, abdominal pain and a moderate degree of ileus. Fasting and fluid replacement is mandatory, but the post-embolisation syndrome is usually self-limited and patients can be discharged safely after 2 days.

Objective response rates vary between 16% and 60%, but less than 2% of patients achieve complete remission. Residual tumor cells recover their blood supply and the tumors continue to grow. Thus, repeated therapy is needed.

Chemoembolisation is currently the only palliative treatment demonstrated to significantly improve patient survival in controlled studies (Llovet 2002). However, it cannot be offered to patients with portal vein thrombosis or HCC-induced portal vein occlusion.

**Radiotherapy applying Yttrium-90 microspheres** has been developed as a novel alternative palliative treatment of liver cancer with unexpectedly impressive anti-tumoral activity in selected individual cases (Sangro 2006, Jacobs 2007, Salem 2006, Liu 2004). Of note, unlike chemoembolisation, some types of microspheres do not occlude the blood vessels and can also be applied in the presence of portal vein thrombosis. Radioembolisation has been shown to induce tumor necrosis. However, there are no data comparing its efficacy to other palliative treatment modalities.

**Molecular-targeted therapeutic strategies** offer new hope for effective palliative therapy in liver cancer. Sorafenib (Nexavar®) is an orally available multi-kinase inhibitor acting on several distinct tyrosine kinases (VEGFR2, PDGFR, c-kit receptor) as well on serine/threonine kinases (b-Raf and p38). Thus, by inhibiting angiogenesis and cellular proliferation, sorafenib can block two of the major signalling pathways of HCC expansion. In a Phase III study (the SHARP trial) involving 602 patients, sorafenib 400 mg BID was well tolerated and associated with improved survival in 44% of patients resulting in 3 months extended survival in treated patients (10.7 months in the sorafenib arm versus 7.9 months in the control arm). Diarrhea, weight loss, hand-foot syndrome and hypophosphatemia were the most important side effects in patients on sorafenib. The efficacy of sorafenib has been confirmed in a second randomized placebo-controlled trial, mostly involving patients with HBV-associated HCC (Cheng 2009). Sorafenib has established itself as first option in patients with HCC who can no longer be treated with potentially more effective local therapies. The SHARP trial largely included patients with preserved liver function. Although the pharmacologic profile is favourable, data in Child-Pugh class B patients are scarce (Abou Alfa 2011). It has been demonstrated that sorafenib can be safely combined with chemoembolisation therapy (Pawlik 2011), although it remains unclear if this strategy actually offers any clinical benefit to the patients. Finally, further antagonists targeting VEGFR, EGFR, ERBB2, Akt/mTor or Wnt/ $\beta$ -catenin signal transmission pathways are currently under evaluation in Phase II studies.

**Systemic chemotherapy** has been proven repeatedly not to offer survival benefits, whether given as a single agent or as part of combination chemotherapy (Llovet 2003). Likewise, anti-hormonal therapy with tamoxifen or octreotide has not provided improved patient survival when studied under controlled conditions (Gallo 2006, Yuen 2002).



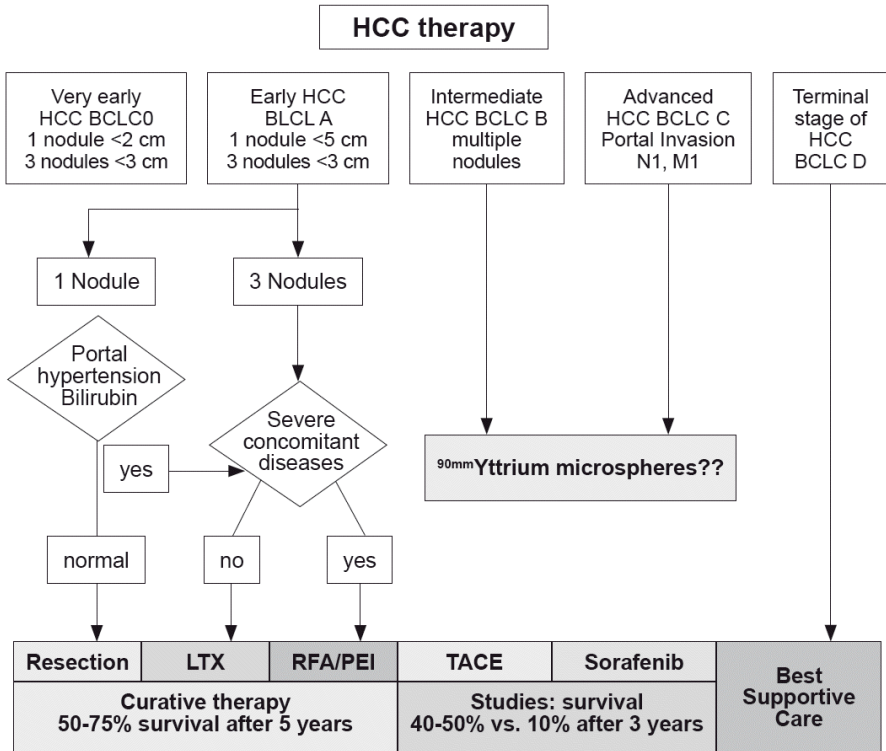


Figure 2. Overview of stage-adapted therapy of liver cancer relative to the BLCL criteria.

## Prophylaxis of liver cancer

Despite conspicuous progress concerning the diagnosis and therapy of HCC, its prognosis has not improved very much over time. Thus, prophylactic measures are of pivotal importance. Vaccination against HBV, as is now recommended by many national vaccination councils, has been proven in Taiwan to markedly reduce HBV infection rates along with the incidence of HCC as a complication of chronic hepatitis B in later life (Lok 2004).

Patients with chronic HBV and patients with chronic hepatitis C should be offered antiviral therapy as effective secondary prophylaxis of HCC. Although HBe-antigen-positive (van Zonneveld 2004) and HBe-antigen-negative patients with chronic hepatitis B showed reduced incidence rates of HCC when successfully treated with interferon (Papatheoridis 2001, Brunetto 2002, Lampertico 2003), antiviral therapy with nucleos(t)ide analogs seems to reduce the risk of HCC less convincingly (Papatheoridis 2010, Papatheoridis 2011). Also several meta-analyses suggest that successful interferon therapy will reduce the risk of HCC in chronic hepatitis C (Camma 2001, Papatheoridis 2001a, Veldt 2004). However, patients who have cirrhosis prior to starting antiviral therapy should be maintained on close HCC surveillance programs, since the risk of developing liver cancer remains high in these patients even after sustained virologic elimination is achieved (Yu 2006).

Therapeutic management of additional risk factors such as obesity and poorly controlled diabetes mellitus provide additional chances for prophylactic measures to reduce the risk of HCC development. Finally, consumption of two or more cups of coffee per day seems to reduce the risk of liver cancer by 40-50% in patients with chronic viral hepatitis (Gelatti 2005, Bravi 2007, Larsson 2007, Wakai 2007).

## References

- Abou-Alfa GK, Amadori D, Santoro A, et al. Safety and Efficacy of Sorafenib in Patients with Hepatocellular Carcinoma (HCC) and Child-Pugh A versus B Cirrhosis. *Gastrointest Cancer Res* 2011;4:40-4. (Abstract)
- Bralet MP, Regimbeau JM, Pineau P, et al. Hepatocellular carcinoma occurring in nonfibrotic liver: epidemiologic and histopathologic analysis of 80 French cases. *Hepatology* 2000;32:200-4. (Abstract)
- Bravi F, Bosetti C, Tavani A, et al. Coffee drinking and hepatocellular carcinoma risk: a meta-analysis. *Hepatology* 2007;46:430-5. (Abstract)
- Brunetto MR, Oliveri F, Coco B, Leandro G, Colombatto P, Gorin JM, Bonino F. Outcome of anti-HBe positive chronic hepatitis B in alpha-interferon treated and untreated patients: a long term cohort study. *J Hepatol* 2002;36:263-70. (Abstract)
- Camma C, Giunta M, Andreone P, Craxi A. Interferon and prevention of hepatocellular carcinoma in viral cirrhosis: an evidence-based approach. *J Hepatol* 2001;34:593-602. (Abstract)
- Calle EE, Rodriguez C, Walker-Thurmond K, Thun MJ. Overweight, obesity, and mortality from cancer in a prospectively studied cohort of U.S. adults. *N Engl J Med* 2003;348:1625-38. (Abstract)
- Chen CJ, Yang HI, Su J, et al. REVEAL-HBV Study Group. Risk of hepatocellular carcinoma across a biological gradient of serum hepatitis B virus DNA level. *JAMA* 2006;295:65-73. (Abstract)
- Cheng AL, Kang YK, Chen Z, et al. Efficacy and safety of sorafenib in patients in the Asia-Pacific region with advanced hepatocellular carcinoma: a phase III randomised, double-blind, placebo-controlled trial. *Lancet Oncol* 2009;10:25-34. (Abstract)
- Cho YK, Kim JK, Kim MY, Rhim H, Han JK. Systematic review of randomized trials for hepatocellular carcinoma treated with percutaneous ablation therapies. *Hepatology*. 2009;49:453-9. (Abstract)
- Davila JA, Morgan RO, Shaib Y, McGlynn KA, El-Serag HB. Diabetes increases the risk of hepatocellular carcinoma in the United States: a population based case control study. *Gut* 2005;54:533-9. (Abstract)
- Donato F, Tagger A, Gelatti U, et al. Alcohol and hepatocellular carcinoma: the effect of lifetime intake and hepatitis virus infections in men and women. *Am J Epidemiol* 2002;155:323-31. (Abstract)
- Falleti E, Fabris C, Cmet S, et al. PNPLA3 rs738409C/G polymorphism in cirrhosis: relationship with the aetiology of liver disease and hepatocellular carcinoma occurrence. *Liver Int* 2011;31:1137-43. (Abstract)
- Gallo C, De Maio E, Di Maio M, et al, CLIP (Cancer of the Liver Italian Programme) Investigators. Tamoxifen is not effective in good prognosis patients with hepatocellular carcinoma. *BMC Cancer* 2006 24;6:196. (Abstract)
- Gelatti U, Covolo L, Talamini R, et al. N-Acetyltransferase-2, glutathione S-transferase M1 and T1 genetic polymorphisms, cigarette smoking and hepatocellular carcinoma: a case-control study. *Int J Cancer* 2005;115:301-6. (Abstract)
- Gelatti U, Covolo L, Franceschini M, et al. Brescia HCC Study Group. Coffee consumption reduces the risk of hepatocellular carcinoma independently of its aetiology: a case-control study. *J Hepatol* 2005;42:528-34. (Abstract)
- Iloeje UH, Yang HI, Su J, Jen CL, You SL, Chen CJ, Risk Evaluation of Viral Load Elevation and Associated Liver Disease/Cancer-In HBV (the REVEAL-HBV) Study Group. Predicting cirrhosis risk based on the level of circulating hepatitis B viral load. *Gastroenterology* 2006;130:678-86. (Abstract)
- International Working Party. Pathologic diagnosis of early hepatocellular carcinoma: a report of the international consensus group for hepatocellular neoplasia. *Hepatology* 2009;49:658-64 (Abstract)

- Jakobs TF, Hoffmann RT, Poepperl G, et al. Mid-term results in otherwise treatment refractory primary or secondary liver confined tumours treated with selective internal radiation therapy (SIRT) using (90)Yttrium resin-microspheres. *Eur Radiol* 2007;17:1320-30.
- Lampertico P, Del Ninno E, Viganò M, et al. Long-term suppression of hepatitis B e antigen-negative chronic hepatitis B by 24-month interferon therapy. *Hepatology* 2003;37:756-63. (Abstract)
- Larsson SC, Wolk A. Coffee consumption and risk of liver cancer: a meta-analysis. *Gastroenterology* 2007;132:1740-5. (Abstract)
- Liaw YF. Prevention and surveillance of hepatitis B virus-related hepatocellular carcinoma. *Semin Liver Dis* 2005;25 Suppl1:40-7. (Abstract)
- Liu MD, Uaje MB, Al-Ghazi MS, et al. Use of Yttrium-90 TheraSphere for the treatment of unresectable hepatocellular carcinoma. *Am Surg* 2004;70:947-53. (Abstract)
- Livraghi T, Meloni F, Di Stasi M, Rolle E, Solbiati L, Tinelli C, Rossi S. Sustained complete response and complications rates after radiofrequency ablation of very early hepatocellular carcinoma in cirrhosis: Is resection still the treatment of choice? *Hepatology* 2008;47:82-9. (Abstract)
- Llovet JM, Bruix J. Systematic review of randomized trials for unresectable hepatocellular carcinoma: Chemoembolization improves survival. *Hepatology* 2003;37:429-42. (Abstract)
- Llovet JM, Bustamante J, Castells A, et al. Natural history of untreated nonsurgical hepatocellular carcinoma: rationale for the design and evaluation of therapeutic trials. *Hepatology* 1999;29:62-7. (Abstract)
- Llovet JM, Real MI, Montana X, et al. Barcelona Liver Cancer Group. Arterial embolisation or chemoembolisation versus symptomatic treatment in patients with unresectable hepatocellular carcinoma: a randomised controlled trial. *Lancet* 2002; 359:1734-9. (Abstract)
- Lok AS. Prevention of hepatitis B virus-related hepatocellular carcinoma. *Gastroenterology*. 2004;127(Suppl 1):S303-9.
- Lopez P, Villanueva A, Llovet JM. Updated systematic review of randomized controlled trials in hepatocellular carcinoma. 2002-2005. *Aliment Pharmacol Ther* 2006; 23:1535-1547. (Abstract)
- Mazzaferro V, Regalia E, Doci R, et al. Liver transplantation for the treatment of small hepatocellular carcinomas in patients with cirrhosis. *N Engl J Med* 1996;334:693-9. (Abstract)
- Nischalke HD, Berger C, Luda C, et al. The PNPLA3 rs738409 148M/M Genotype Is a Risk Factor for Liver Cancer in Alcoholic Cirrhosis but Shows No or Weak Association in Hepatitis C Cirrhosis. *PLoS One* 2011;6:e27087. (Abstract)
- Otto G, Herber S, Heise M, et al. Response to transarterial chemoembolization as a biological selection criterion for liver transplantation in hepatocellular carcinoma. *Liver Transpl* 2006;12:1260-7. (Abstract)
- Papatheodoridis GV, Manesis E, Hadziyannis SJ. The long-term outcome of interferon-alpha treated and untreated patients with HBeAg-negative chronic hepatitis B. *J Hepatol* 2001;34:306-13. (Abstract)
- Papatheodoridis GV, Papadimitropoulos VC, Hadziyannis SJ. Effect of interferon therapy on the development of hepatocellular carcinoma in patients with hepatitis C virus-related cirrhosis: a meta-analysis. *Aliment Pharmacol Ther* 2001;15:689-98. (Abstract)
- Papatheodoridis GV, Manolakopoulos S, Touloumi G, et al.; HEPNET. Greece Cohort Study Group. Virological suppression does not prevent the development of hepatocellular carcinoma in HBeAg-negative chronic hepatitis B patients with cirrhosis receiving oral antiviral(s) starting with lamivudine monotherapy: results of the nationwide HEPNET. Greece cohort study. *Gut* 2011;60:1109-16.
- Papatheodoridis GV, Lampertico P, Manolakopoulos S, Lok A. Incidence of hepatocellular carcinoma in chronic hepatitis B patients receiving nucleos(t)ide therapy: a systematic review. *J Hepatol* 2010;53:348-56. (Abstract)
- Parkin DM, Bray F, Ferlay J, Pisani P. Global cancer statistics, 2002. *CA Cancer J Clin* 2005;55:74-108. (Abstract)
- Pawlik TM, Reyes DK, Cosgrove D, Kamel IR, Bhagat N, Geschwind JF. Phase II trial of sorafenib combined with concurrent transarterial chemoembolization with drug-eluting beads for hepatocellular carcinoma. *J Clin Oncol* 2011;29:3960-7. (Abstract)

- Pomfret EA, Washburn K, Wald C, et al. Report of a national conference on liver allocation inpatients with hepatocellular carcinoma in the United States. *Liver Transpl* 2010;16:262-78. ([Abstract](#))
- Poon RT, Fan ST, Lo CM, Liu CL, Wong J. Difference in tumor invasiveness in cirrhotic patients with hepatocellular carcinoma fulfilling the Milan criteria treated by resection and transplantation: impact on long-term survival. *Ann Surg* 2007;245:51-8. ([Abstract](#))
- Salem R, Hunter RD. Yttrium-90 microspheres for the treatment of hepatocellular carcinoma: a review. *Int J Radiat Oncol Biol Phys* 2006;66(2 Suppl):S83-8. ([Abstract](#))
- Sangro B, Bilbao JI, Boan J, et al. Radioembolization using 90Y-resin microspheres for patients with advanced hepatocellular carcinoma. *Int J Radiat Oncol Biol Phys* 2006;66:792-800. ([Abstract](#))
- van Zonneveld M, Honkoop P, Hansen BE, et al. Long-term follow-up of alpha-interferon treatment of patients with chronic hepatitis B. *Hepatology* 2004;39:804-10. ([Abstract](#))
- Veldt BJ, Saracco G, Boyer N, et al. Long term clinical outcome of chronic hepatitis C patients with sustained virological response to interferon monotherapy. *Gut* 2004;53:1504-8. ([Abstract](#))
- Wakai K, Kurozawa Y, Shibata A, et al. JACC Study Group. Liver cancer risk, coffee, and hepatitis C virus infection: a nested case-control study in Japan. *Br J Cancer* 2007;97:426-8. ([Abstract](#))
- Vilana R, Forner A, Bianchi L, et al. Intrahepatic peripheral cholangiocarcinoma in cirrhosis patients may display a vascular pattern similar to hepatocellular carcinoma on contrast-enhanced ultrasound. *Hepatology* 2010;51:2020-9. ([Abstract](#))
- Yao FY. Should surveillance for hepatocellular carcinoma be increased in patients with cirrhosis and small liver nodules? *Nature Clin Pract Gastroenterol Hepatol* 2006;3:544-5. ([Abstract](#))
- Yao FY, Ferrell L, Bass NM, et al. Liver transplantation for hepatocellular carcinoma: expansion of the tumor size limits does not adversely impact survival. *Hepatology* 2001;33:1394-403. ([Abstract](#))
- Yu ML, Lin SM, Lee CM, et al. A simple noninvasive index for predicting long-term outcome of chronic hepatitis C after interferon-based therapy. *Hepatology* 2006;44:1086-97. ([Abstract](#))
- Yuen MF, Poon RT, Lai CL, et al. A randomized placebo-controlled study of long-acting octreotide for the treatment of advanced hepatocellular carcinoma. *Hepatology* 2002;36:687-91. ([Abstract](#))
- Zhang BH, Yang BH, Tang ZY. Randomized controlled trial of screening for hepatocellular carcinoma. *J Cancer Res Clin Oncol* 2004;130:417-422. ([Abstract](#))

## 22. Update in Transplant Hepatology

*S. Beckebaum, G. Gerken, V. R. Cicinnati*

### Introduction

The first attempt at heterotopic grafting of a liver in a dog was reported more than 50 years ago (Welch 1955). The first known experimental orthotopic liver transplantation (LT) was reported in 1956 at the University of California (Cannon 1956). In the early sixties, a human-to-human LT was performed in a 3-year-old child with congenital biliary atresia who died intraoperatively (Starzl 1963). The next two transplant recipients lived for 22 days and 1 week, respectively (Starzl 1963). Starzl finally transplanted several patients with success in 1967 (Starzl 1968).

With the advances in immunosuppression, surgical techniques, organ preservation and improvements in patient management, LT has become the gold standard in the treatment of advanced chronic liver disease and fulminant hepatic failure. This chapter focuses on important issues in the field of transplant hepatology and may provide helpful information to physicians involved in the care of adult LT recipients. It includes indications for LT, current organ allocation policy, pretransplant evaluation, management while on the waiting list, living donor liver transplantation (LDLT), and management of early and long-term complications post-LT.

### Timing and indications for liver transplantation

Appropriate selection of candidates and timing of LT is crucial in reducing mortality and improving outcomes in LT recipients. A patient is considered too healthy to undergo LT if the expected survival is greater without LT. Therefore, criteria are needed in order to select patients who can most benefit from transplantation. In 2002, the Organ Procurement and Transplantation Network, along with the United Network of Organ Sharing (UNOS), developed a new system based on the model for end-stage liver disease (MELD) (Table 1) to prioritize patients on the waiting list. In the Eurotransplant countries, the Child-Pugh Turcotte score was replaced by the MELD score in December 2006.

The lab MELD score is a numerical scale using the three laboratory parameters depicted in Table 1 and ranging from 6 (less ill) to 40 (severely ill).

In a large study (Merion 2005) investigating the survival benefit of LT candidates, those transplanted with a MELD score <15 had a significantly higher mortality risk as compared to those remaining on the waiting list, while candidates with a MELD score of 18 or higher had a significant transplant benefit.

**Table 1. Calculation of the MELD\* Score.**

---


$$\begin{aligned} \text{MELD Score} = & 0.957 \times \log (\text{creatinine mg/dL}) \\ & 0.378 \times \log (\text{bilirubin mg/dL}) \\ & 1.120 \times \log (\text{INR}^{**}) \\ & + 0.643 \end{aligned}$$


---

\*Model of End-stage Liver Disease

\*\*International Normalized Ratio

However, the MELD score does not accurately predict mortality in approximately 15-20% of patients. Therefore MELD-based allocation allows exceptions for patients whose score may not reflect the severity of their liver disease. These exceptions include hepatocellular carcinoma (HCC), non-metastatic hepatoblastoma, adult polycystic liver degeneration, primary hyperoxaluria type 1, small for size syndrome, cystic fibrosis, familial amyloid polyneuropathy, hepatopulmonary syndrome, portopulmonary hypertension, urea cycle disorders, hereditary hemorrhagic telangiectasia (Osler-Weber-Rendu disease), hemangioendothelioma of the liver, biliary sepsis, primary sclerosing cholangitis (PSC) and cholangiocarcinoma. Patients with standard exceptions will be assigned a higher MELD score (match MELD) than that assigned by the patient's laboratory test results (lab MELD). This results in an increasing proportion of patients transplanted for HCC and other exceptions over time (Massie 2011).

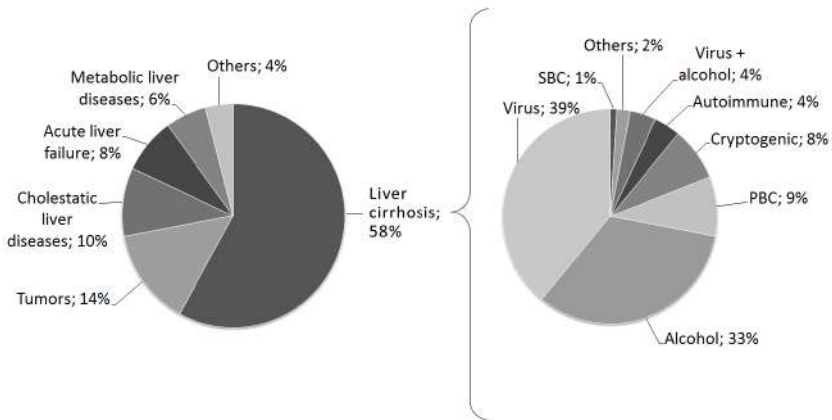
MELD has proved to be accurate as a predictor of waiting list mortality, but has shown to be less accurate to predict post-transplant outcome. For instance, MELD allocation resulted in decreased waiting list mortality; whereas post-transplant morbidity has increased due to transplantation of a higher proportion of sicker recipients with MELD scores >30 (Dutkowski 2011). Moreover, since the introduction of MELD, the quality of donor organs has been impaired and the threshold for organ allocation has increased from a match MELD of 25 to 34 (Schlitt 2011).

A potential modification of the MELD allocation system currently under investigation is to allocate organs by not only taking into account pretransplant mortality but also donor-related factors for estimation of the donor risk index (DRI) (Feng 2006) and post-transplant mortality.

Furthermore, standardization of laboratory assays and variants of MELD including incorporation of parameters such as sodium or cholinesterase have been proposed to overcome the limitations of the current scoring system (Choi 2009, Weissmüller 2008).

Candidates for LT must have irreversible acute or chronic end-stage liver disease. Hepatitis C virus (HCV)- or alcohol-induced liver disease account for the most common disease indications in adults with liver cirrhosis (<http://www.eltr.org>) (Figure 1). Other indications include cholestatic liver disorders (primary biliary

cirrhosis [PBC], PSC), hepatitis B virus (HBV) infection, autoimmune hepatitis (AIH), inherited metabolic diseases (Wilson's Disease, hemochromatosis,  $\alpha$ -1-antitrypsin deficiency), nonalcoholic steatohepatitis, HCC, and acute or acute-on-chronic hepatic failure. In children, biliary atresia and metabolic liver diseases are the most common indications. Contraindications for LT include active alcohol and drug abuse, extrahepatic malignancies, sepsis, uncontrolled pulmonary hypertension, and coexistent medical disorders such as severe cardiopulmonary condition, technical or anatomical barriers such as thrombosis of the entire portal and superior mesenteric venous system. Previous malignancy history must be carefully considered and likelihood of recurrence estimated.



**Figure 1. Indications for liver transplantation (LT).** Primary diseases leading to LT in Europe 1988 - 2010 (Data kindly provided from European Liver Transplant Registry, <http://www.eltr.org>).

## Patient evaluation

Evaluation of a potential transplant candidate is a complex and time-consuming process that requires a multidisciplinary approach. Requirements for evaluation may differ slightly between transplant centers. The evaluation process must identify extrahepatic diseases that may exclude the patient from transplantation or require treatment before surgical intervention. The protocol we use for evaluation of potential transplant candidates is shown in Table 2.

## Pretransplant management issues

In cases of recurrent variceal hemorrhage despite prior interventional endoscopic therapy (and non-selective beta-blockade) or refractory ascites, transjugular intrahepatic portosystemic shunts (TIPS) have been used as an approach to lower portal pressure and as a bridging therapy for transplant candidates. The identification of predisposing factors and the application of lactulose, nonabsorbed antibiotics and protein-restricted diets remain essential for prophylaxis and management of hepatic encephalopathy (HE).

**Table 2. Evaluation protocol for potential transplant candidates.**


---

▪ Physical examination
▪ Diagnostic tests (baseline laboratory testing; serologic, tumor/virologic, and microbiological screening; autoantibodies; thyroid function tests)
▪ Ultrasonography with Doppler
▪ Abdominal MRI or CT scan
▪ Chest X-rays
▪ Electrocardiogram (ECG), stress ECG, 2-dimensional echocardiography (if abnormal or risk factors are present: further cardiological screening)
▪ Upper and lower endoscopy
▪ Pulmonary function testing
▪ Mammography (females >35 years)
▪ Physician consultations (anesthesiologist, gynecologist, urologist, cardiologist, neurologist, dentist, ENT physician)
▪ A meticulous psychosocial case review (medical specialist in psychosomatic medicine, psychiatry or psychology)

---

Hepatorenal syndrome (HRS) represents a complication of end-stage liver disease and is a risk factor for acute kidney injury (AKI) in the early postoperative phase (Saner 2011). It is classified into type 1 HRS characterized by a rapid impairment of renal function with a poor prognosis; type 2 HRS is a moderate steady renal impairment. Vasoconstrictors including commonly used terlipressin in combination with volume expansion, have been shown to be effective for restoration of arterial blood flow and serve as a bridging therapy to LT. Extracorporeal liver support systems based on exchange or detoxification of albumin have been successfully employed in indicated cases. After wait-listing, laboratory values must be updated according to the recertification schedule shown in Table 3.

**Table 3. Recertification schedule of MELD data.**

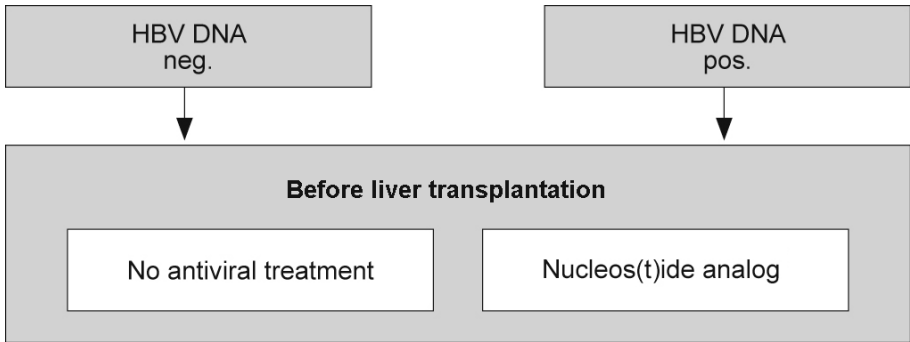
Score	Recertification	Lab values
≥25	every 7 days	≤48 hours old
24-19	every 30 days	≤7 days old
18-11	every 90 days	≤14 days old
≤10	every year	≤30 days old

Special attention regarding specific, disease-related therapy prior to surgery should be given to transplant candidates undergoing LT for HCC or virally-related liver diseases.

## Waiting list monitoring of hepatitis B liver transplant candidates

The goal of antiviral therapy in HBV patients on the waiting list is to achieve viral suppression to undetectable HBV DNA levels using sensitive tests (Figure 2) (Cornberg 2011). Several studies have demonstrated clinical benefits under viral suppression in patients with decompensated cirrhosis as reflected by a decrease in CPT score, improvement of liver values and resolution of clinical complications (Kapoor 2000, Schiff 2007, Nikolaidis 2005).





**Figure 2. Management of HBV patients prior to liver transplantation (LT).** In all viremic patients awaiting LT for HBV-related liver damage, efficient antiviral therapy is required. Suppression of HBV DNA may lead to clinical stabilisation resulting in removal from the waiting list or in a delay in the need for LT. Neg., negative, pos., positive.

A major concern of long-term lamivudine (LAM) therapy is the emergence of mutations in the YMDD motif of the DNA polymerase which could result in clinical decompensation in patients with liver cirrhosis (Beckebaum 2008, Beckebaum 2009). Therefore potent nucleos(t)ide analogs (entecavir [ETV] or tenofovir [TDF]) with a high resistance barrier are preferred.

### Waiting list monitoring and treatment of hepatitis C liver transplant candidates

The number of studies investigating the tolerability and efficacy of antiviral therapy in HCV patients before LT is limited (Crippin 2002, Iacobellis 2007, Everson 2005, Triantos 2005). Wait-listed patients who have a viral response on antiviral therapy have a lower reinfection rate and better outcome after LT (Thomas 2003, Picciotto 2007). Thus, there is an indication for therapy with pegylated interferon (PEG-IFN) plus ribavirin (RBV) in patients with compensated HCV cirrhosis on the waiting list. Results from antiviral clinical studies show sustained viral response (SVR) rates between 20% and 40% (Melero 2009). Adverse effects are frequent including cytopenias, bacterial infections and hepatic decompensation requiring dose reduction or treatment withdrawal. Hematopoietic growth factors have shown to increase patient compliance and to avoid dose reductions, but it remains questionable whether they result in higher SVR rates. Antiviral therapy in decompensated cirrhosis and with MELD score  $\geq 18$  should be restricted to selected cases and monitored by a transplant center.

### Adjunctive treatment and staging of HCC transplant candidates

Under MELD allocation, patients must meet the Milan criteria (one tumor  $\leq 5$  cm in diameter or up to three tumors, all  $\leq 3$  cm) to qualify for exceptional HCC waiting list consideration. Diagnosis of HCC is confirmed if the following criteria are met according to the German Guidelines for Organ Transplantation (Bundesärztekammer 2008): (1) liver biopsy-proven or (2) AFP  $>400$  ng/mL and hypervascular liver lesion detectable in one imaging technique (magnetic resonance

imaging [MRI], spiral computed tomography [CT], angiography) or (3) hypervascular liver lesion detectable in 2 different imaging techniques. Patients are registered at a MELD score equivalent to a 15% probability of pretransplant death within 3 months. Patients will receive additional MELD points equivalent to a 10% increase in pretransplant mortality to be assigned every 3 months until these patients receive a transplant or become unsuitable for LT due to progression of their HCC. The listing center must enter an updated MELD score exception application in order to receive additional MELD points. The US National Conference on Liver Allocation in Patients with HCC recommended the introduction of a calculated continuous HCC priority score, that incorporates the MELD score, AFP level and rate of tumor growth, for identifying patients with a good vs. a poor outcome (Pomfret 2010). Further investigations are necessary to determine the survival benefit of HCC patients considering these features.

Pre-listing, the patient should undergo a thorough assessment to rule out extrahepatic spread and/or vascular invasion. The assessment should include CT scan or MRI of the abdomen, pelvis and chest. We perform trimonthly routine follow-up examinations (MRI or CT scan) of wait-listed HCC patients for early detection of disease progression. It has been shown that waiting list drop-out rates can be reduced by the application of bridging therapies such as transarterial chemoembolisation or radiofrequency ablation (Roayie 2007). Recently, transarterial radionuclide therapies such as Yttrium-90 microsphere transarterial radioembolisation (TARE) have been tested for bridging therapy in selected cases (Toso 2010, Khalaf 2010). Bridging therapy should be considered in particular in patients outside of the Milan criteria, with a likely waiting time of longer than 6 months and those within the Milan criteria with high-risk characteristics of HCC. Sorafenib has been administered in a few studies before LT to investigate the safety and efficacy of this oral multikinase inhibitor in the neoadjuvant setting (Fijiki 2011, Di Benedetto 2011).

Accurate discrimination of HCC patients with good and poor prognosis by specific criteria (genomic or molecular strategies) is highly warranted to select appropriate treatment options (Tournoux-Facon 2011, Marsh 2003, Finkelstein 2003). In patients with alcohol-related liver disease and HCC, a multidisciplinary approach and thorough work-up of both the alcoholic and oncologic problem is mandatory (Sotiropoulos 2008a).

## **Living donor liver transplantation: indications, donor evaluation, and outcome**

LDLT was introduced in 1989 with a successful series of pediatric patients (Broelsch 1991). Adult-to-adult LDLT (ALDLT) was first performed in Asian countries where cadaveric organ donation is rarely practiced (Sugawara 1999, Kawasaki 1998). LDLT peaked in the US in 2001 (Qiu 2005) but thereafter the numbers declined by 30% over the following years (Vagefi 2011). A decline over time was also observed in Europe, although LDLT activity increased in Asia (Moon 2011).

The evaluation of donors is a cost-effective although time-consuming process. Clinical examinations, imaging studies, special examinations, biochemical parameters, and psychosocial evaluation prior to donation varies from center to

center and has been described elsewhere (Valentin-Gamazo 2004). Using Germany as an example, the expenses for evaluation, hospital admission, surgical procedure, and follow-up examinations of donors are paid by the recipient's insurance. Due to the increasing number of potential candidates and more stringent selection criteria, rejection of potential donors has been reported in about 69-86% of cases (Valentin-Gamazo 2004, Pascher 2002). The advantages of LDLT include the feasibility of performing the operation when medically indicated and the short duration of cold ischemia time.

The surgical procedures for LDLT are more technically challenging than those for cadaver LT. In the recipient operation, bile duct reconstruction has proven to be the most challenging part of the procedure with biliary complications ranging from 15% to 60% (Sugawara 2005).

Regarding donor outcome, morbidity rates vary considerably in the literature (Patel 2007, Beavers 2002). Possible complications include wound infection, pulmonary problems, vascular thrombosis with biliary leaks, strictures, and incisional hernia. Biliary complications are the most common postoperative complication in LDLT and occur in up to 7% of donors (Perkins 2008, Sugawara 2005). Liver regeneration can be documented with imaging studies and confirmed by normalization of bilirubin, liver enzymes, and synthesis parameters. LDLT should be performed only by established transplant centres with appropriate medical expertise.

## **Perioperative complications**

Cardiac decompensation, respiratory failure following reperfusion, and kidney failure in the perioperative LT setting constitutes a major challenge for the intensive care unit. Early dialysis has been shown to be beneficial in patients with severe acute kidney injury (AKI) (stage III according to the classification of the Acute Kidney Injury Network) (Bellomo 2004), whereas treatment with dopamine or loop diuretics have shown to be associated with worse outcome. Preventative strategies of AKI include avoidance of volume depletion and maintenance of a mean arterial pressure >65 mmHg (Saner 2011).

Despite advances in organ preservation and technical procedures, postoperative complications due to preservation/reperfusion injury have not markedly decreased over the past several years. Typical histological features of preservation and reperfusion injury include centrilobular pallor and ballooning degeneration of hepatocytes. Bile duct cells are more sensitive to reperfusion injury than hepatocytes (Washington 2005) resulting in increased levels of bilirubin, gamma-glutamyl transpeptidase (GGT) and alkaline phosphatase (AP). Vascular complications such as hepatic artery thrombosis (HAT) occur in 1.6-4% of patients. Thus, Doppler exams of the hepatic artery and portal vein are frequently performed in the early postoperative setting. HAT in the early postoperative period can be managed with thrombectomy. Late HAT with complication of bile duct strictures is managed by interventional endoscopic retrograde cholangiography (ERC) but requires retransplantation in the majority of patients. Early portal vein thrombosis is rare (<1%) but may lead to graft loss if not revascularized.

Primary non-functioning graft (PNFG) may be clinically obvious immediately after revascularization of the allograft. Early signs of liver dysfunction include prolonged coagulation times, elevated liver enzymes (transaminases, cholestasis

parameter) without a downward trend, rising lactate, and hypoglycemic episodes. PNFG is a critical situation and requires immediate retransplantation.

Death within the first year after LT is often associated with bacterial infections. Management of infections due to multidrug-resistant gram-positive pathogens represent a major therapeutic challenge in the transplant setting (Radunz 2011).

Overall incidence of fungal infections in LT recipients has declined due to early identification and treatment of high-risk patients. However, overall mortality rate for invasive candidiasis and aspergillosis remains high (Liu 2011).

The clinical symptoms of acute cellular rejection are non-specific, may not be apparent or may manifest as fever, right upper quadrant pain, and malaise. A liver biopsy is indispensable for confirming the diagnosis of acute rejection. High dose corticosteroids (3 days of 500-1000 mg methylprednisolone) are the first-line treatment for acute rejection.

## Long-term complications after liver transplantation

Management issues for the long term include opportunistic infections, chronic ductopenic rejection, side effects due to immunosuppression including cardiovascular complications and renal dysfunction, *de novo* malignancies, biliary complications, osteoporosis and disease recurrence.

### Opportunistic infections

Opportunistic infections in the medium and long term after LT are primarily viral and fungal in origin. Opportunistic bacterial infections are uncommon after 6 months in patients receiving stable and reduced maintenance doses of immunosuppression with good graft function.

Cytomegalovirus (CMV) infection plays an important role in the LT setting (Andrews 2011) (Figure 3). Current guidelines recommend antiviral prophylaxis over pre-emptive therapy in preventing CMV disease in high-risk LT recipients (CMV-seronegative recipients of organs from CMV-seropositive donors [D+/R-]). Delayed-onset CMV disease occurs in 15-38% of CMV D+/R- LT patients with prophylactic treatment over 3 months (Eid 2010). A controlled clinical trial demonstrated that valganciclovir, an oral prodrug of ganciclovir, is as effective and safe as intravenous (IV) ganciclovir for the prophylaxis of CMV disease in solid organ (including liver) transplant recipients (Paya 2004). In the kidney transplant setting, the Impact study demonstrated a marked reduction in the incidence of CMV disease extending valganciclovir prophylaxis from 100 to 200 days (Humar 2010). However, side effects and financial burden of this prolonged approach need to be considered. In cases of ganciclovir-resistant CMV disease, alternative therapeutic options include CMV hyperimmune globulins, or in rare cases, antiviral medication (foscarnet, cidofovir or leflunomide) (Eid 2010).

Occurrence of post-transplant lymphoproliferative disease (PTLD) in the first year after solid-organ transplantation is typically related to Epstein-Barr virus (EBV) infection. EBV-seronegativity of the recipient before infection, high EB viral load, intensity of immunosuppression and young age have been reported as risk factors for PTLD (Smets 2002). Outcomes have improved since rituximab has been incorporated into treatment regimens (Kamdar 2011). Therapeutic management

options include reduction of immunosuppression, rituximab, combination chemotherapy, and adoptive immunotherapy.

Oral reactivation of human herpes simplex virus-1 (HSV-1) after LT is common. Development of varicella-zoster virus (HHV-3) after LT is typically related to intense immunosuppressive therapy and its therapy does not differ from the non-transplant setting. There is a potential role of human herpes virus (HHV)-6 and HHV-7 as copathogens in the direct and indirect illnesses caused by CMV. To what extent HHV-6 and HHV-7 may be directly causing symptomatic disease is not clear (Razonable 2009).

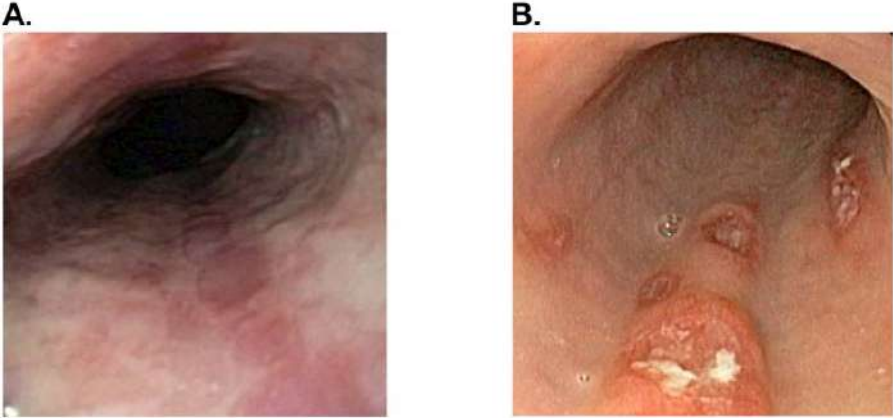


Figure 3. Cytomegalovirus (CMV) infection of the upper gastrointestinal tract. A. Liver-transplanted patient complaining of dysphagia and epigastric discomfort with multiple longitudinal esophageal ulcers seen at upper endoscopy. B. Endoscopic findings of deep esophageal ulcerations with fibrinoid necrosis in another immunocompromised patient. In both cases, lesions were caused by CMV infection. Diagnosis depends on a positive mucosal biopsy, which should include specimens from the ulcer margins and ulcer base. Hematoxylin and eosin staining typically reveals "owl's-eye" cytoplasmic and intranuclear inclusion bodies.

## Chronic ductopenic rejection

Advances in immunosuppressive regimens have greatly reduced the incidence of chronic ductopenic rejection and allograft failure. Chronic rejection begins within weeks to months or years after LT and affects about 4% to 8% of patients (Neuberger 1999). The most widely recognized manifestation of chronic rejection is obliterative arteriopathy and damage or loss of small ducts (Demetris 1997). Chronic rejection may appear indolently and might only become apparent as liver test injury abnormalities (GGT, AP, bilirubin, transaminases). The diagnosis needs to be confirmed by histopathologic examination. Switching the baseline immunosuppression from cyclosporine A (CSA) to tacrolimus (TAC) and initiating mycophenolate mofetil (MMF) rescue therapy represents a treatment option in these patients (Daly 2002).

## CNI-induced nephrotoxicity and alternative immunosuppressive protocols

Despite the introduction of new immunosuppressive agents (Table 4), calcineurin inhibitors (CNI) remain the key drugs of most immunosuppressive regimens. Both CSA and TAC inhibit the calcineurin-calmodulin complex and therefore IL-2 production. Renal failure, mainly due to CNI nephrotoxicity, is the most common complication following orthotopic LT. The incidence of chronic renal dysfunction has been reported in up to 70% of patients in the long term after LT (Afonso 2008, Ziolkowski 2003). End stage renal disease has been described to occur in 18% of patients during a post-transplant follow-up of 13 years (Gonwa 2001).

In LT patients with CNI-induced nephrotoxicity, a complete replacement of CNI with conversion to MMF has shown conflicting results with respect to occurrence of rejection ranging between 0% and 60% (Creput 2007, Moreno 2003, Schmeding 2011, Moreno 2004). MMF inhibits inosine monophosphate dehydrogenase, a critical enzyme in the *de novo* pathway of purine synthesis. Results from previous studies with immunosuppressive regimens including MMF and minimal CNI treatment suggest a significant improvement in renal function in this patient group (Beckebaum 2011, Cicinnati 2007a, Beckebaum 2004a, Cantarovich 2003, Garcia 2003, Raimondo 2003).

*De novo* immunosuppression with MMF combined with induction therapy and delayed CNI introduction is another approach to reduce CNI-related nephrotoxicity especially in patients with higher MELD score or significant renal dysfunction. In a randomized clinical trial, a daclizumab/MMF/delayed low-dose TAC-based regimen was compared with a standard TAC/MMF regimen (Yoshida 2005). In both study arms, corticosteroids were tapered over time. Statistically significant higher median GFR were found in the delayed CNI group, although acute rejection episodes were not statistically significant different in either group. Similar results have been found in two retrospective studies in LT patients receiving thymoglobulin induction therapy and delayed initiation of CNI (Bajjoka 2008, Soliman 2007). The group from Regensburg initiated a single arm pilot study to determine the safety and efficacy of a CNI-free combination therapy (basiliximab induction/MPA and delayed [10 days post-transplant] sirolimus [SRL]) in patients with impaired renal function (GFR <50 ml/min and/or serum creatinine >1.5 mg/dL) at LT (Schnitzbauer 2010a). The study design stipulates that if at least 8 of the 9 patients do not present with steroid-resistant acute rejection within 30 days after LT, an additional 20 patients will be included. Results from this “bottom-up” immunosuppressive strategy need to be awaited to determine if this strategy works to prevent or avoid further renal dysfunction during follow-up after LT. Moreover, a flaw of combined MMF and mTOR inhibitors therapy are agonistic side effects such as bone marrow suppression, which may limit their combined use in a substantial proportion of patients.

Another approach to maintain renal preservation is replacement of CNI by mTOR inhibitors such as SRL or everolimus (EVL) (Sanchez 2005, Harper 2011, Saliba 2011, Kawahara 2011). Reported side effects of mTOR inhibitors include increased incidence of wound infection and dehiscence, hepatic artery thrombosis, hyperlipidemia, thrombocytopenia, leucopenia, and anemia. The antifibrotic effect of mTOR inhibitors may provide an explanation for impaired wound healing (Watson 1999).

In a recently published randomized controlled study, patients were treated with CSA for the first 10 days, then randomized to receive EVL plus CSA up to day 30, and then either continued on EVL monotherapy (EVL group) or maintained on CSA with or without MMF (control group) (Masetti 2010). One-year results showed that MDRD was significantly better in the EVL monotherapy group as compared to the control group. Results from two multicenter, randomized, Phase III studies (ClinicalTrials.gov Identifiers: NCT00378014 & NCT00622869) comparing EVL-based regimen versus CNI-based regimen in *de novo* LT recipients will add further information with respect to the role of mTOR inhibitors for renal preservation after LT.

**Table 4. Clinically used immunosuppressive agents in liver transplantation.**

Immunosuppressant Class	Immunosuppressive Agent
Corticosteroids	Prednisone, prednisolone, methylprednisolone
Calcineurin inhibitors	Cyclosporin A, tacrolimus
Antimetabolites	Mycophenolate mofetil, azathioprine
mTOR Inhibitors	Sirolimus, everolimus
Polyclonal antibodies	Antithymocyte globulin (ATG)
Monoclonal anti-CD3 antibodies	Muromonab-CD3 (OKT3)
Chimeric monoclonal antibodies	Anti-IL-2 inhibitors (basiliximab)
Monoclonal anti-CD52 antibodies	Alemtuzumab (campath-1H)

## Other side effects of CNI

Beside potential nephrotoxicity, CNI therapy is associated with side effects that include cardiovascular complications, tremor, headache, electrolyte abnormalities, hyperuricemia, hepatotoxicity, and gastrointestinal symptoms. Neurotoxicity, including tremor, paresthesia, muscle weakness, and seizures, more often occurs in TAC-treated patients; whereas gingival hyperplasia, as a rare event, and hirsutism are associated with CSA treatment.

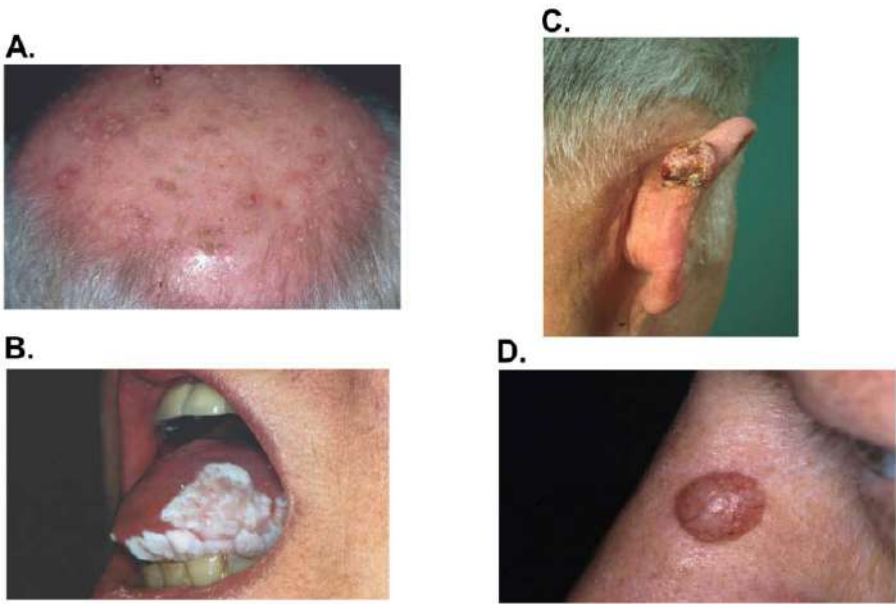
Cardiovascular side effects due to CNI and steroids include hyperlipidemia, arterial hypertension, and diabetes (Beckebaum 2004b).

The prevalence of new-onset diabetes mellitus after LT has been reported to occur in 9-21% of patients (John 2002, Konrad 2000). The prevalence of post-transplant diabetes is even higher if cofactors such as hepatitis C are present. In various studies, the diabetogenic potential has been reported to be higher in patients receiving TAC than in those receiving CSA. In contrast, CSA has a more pronounced effect on lipid levels. CSA can act by modulating the activity of the LDL receptor or by inhibiting the bile acid 26-hydroxylase that induces bile acid synthesis from cholesterol.

## Corticosteroid minimization/avoidance protocols

There is ongoing discussion of steroid avoidance due to dyslipidemia, osteoporosis, development of cataracts, weight gain, hypertension, and a deleterious impact on glucose control. A recently published literature review (Lerut 2009) analysed the actual status of corticosteroid minimization protocols in LT based on a detailed analysis of 51 peer- and 6 non-peer-reviewed studies. Results from the majority of

studies showed that these protocols have clearly metabolic benefits and are safe with respect to graft and patient survival. Other research groups have reported encouraging findings with steroid-free protocols including basiliximab induction therapy (Filipponi 2004, Llado 2008, Becker 2008). A steroid-free alemtuzumab induction regimen resulted in less hypertension and rejection but with more infectious complications. So far, the overall benefit of alemtuzumab induction in LT recipients remains questionable (Levitsky 2011).



**Figure 4. Non-melanoma skin cancers and liver transplantation (LT).** Organ transplant recipients have an increased risk of development of non-melanoma skin cancers as compared to the non-transplant setting. Premalignant lesions such as actinic keratoses [A] are predominantly located on sun-exposed areas. Squamous cell carcinoma [B,C] is the most frequent skin cancer after LT followed by basal cell carcinoma [D] (Photographs kindly provided by PD Dr. Hillen, Transplant Dermatology Outpatient Unit, Department of Dermatology, University Hospital Essen, Germany).

### ***De novo* malignancies**

Incidence of malignancies is higher in transplant patients and depends on the length of follow-up, characteristics of the transplant population, choice of immunosuppression and era in which the LT was performed (Buell 2005, Fung 2001). A cumulative risk has been reported of 10%, 24%, 32% and 42% at 5, 10, 15 and 20 years, respectively, for development of *de novo* cancers after LT (Finkenstedt 2009). The highest risks in the transplant setting are nonmelanoma skin cancers, mainly squamous cell carcinoma and basal cell carcinoma (Figure 4).

Premalignant lesions such as actinic keratoses are mostly located on sun-exposed areas. Squamous cell carcinoma and basal cell carcinoma are increased by factors of ~65-200 and ~10, respectively, in organ transplant recipients as compared to the immunocompetent population (Ulrich 2008). An annual routine dermatological



follow-up exam, limitation of sun exposure and protective measures including sunscreens are highly recommended for transplant patients.

A higher incidence of colon cancer in patients with inflammatory bowel disease who are transplanted for PSC has been reported in the literature (Hanouneh 2011). It is therefore necessary to maintain an adequate colonoscopic surveillance in these patients even in the absence of bowel symptoms or active disease at regular intervals (Fevry 2011). A trend has been recently reported toward an increased incidence of advanced colon polyps and colon carcinoma in patients transplanted for other diseases than PSC after LT. However, larger studies are needed to determine whether post-transplant colon cancer surveillance should be performed more frequently than in the non-transplant setting (Rudraraju 2008).

Recent studies reported a significantly higher incidence of aerodigestive cancer including lung cancer among patients who underwent LT for alcohol-related liver disease (Vallejo 2005, Jimenez 2005). A Spanish transplant group recommended annual screening for oropharyngeal tumors in patients with a history of alcohol overconsumption (Benlloch 2004). SRL exerts antiangiogenic activities that are linked to a decrease in production of vascular endothelial growth factor (VEGF) and to a markedly inhibited response of vascular endothelial cells to stimulation by vascular endothelial growth factor (VEGF) (Guba 2002). Furthermore, the ability of SRL to increase the expression of E-cadherin suggests a mechanism for blocking regional tumor growth and for inhibiting metastatic progression. Therefore, we give special consideration for mTOR inhibitor-based immunosuppressive regimens not only patients transplanted for HCC but also those with *de novo* malignancies after LT.

## Biliary complications

Biliary leaks generally occur as an early post-transplant complication. In patients with biliary stones, endoscopic sphincterotomy and stone extraction are the treatment of choice.

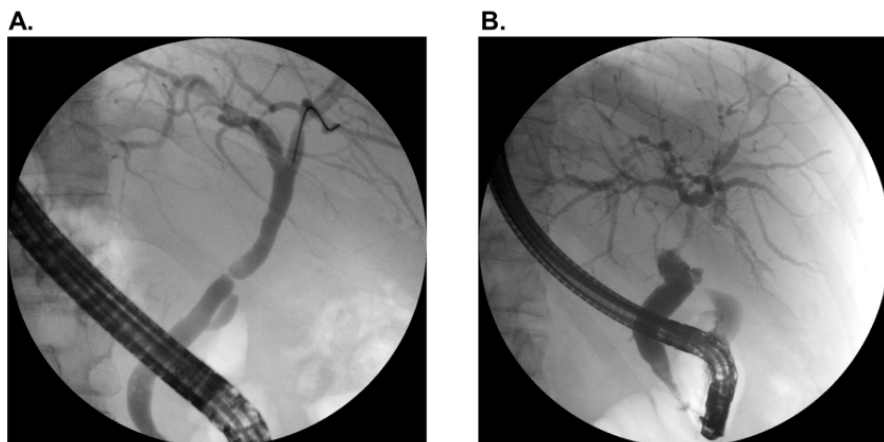
Biliary strictures are one of the most common complications after LT, with a reported incidence of 5.8-34% (Graziadei 2006). Early anastomotic strictures (AS) usually have a technical origin; while strictures appearing later have a multifactorial origin. Nonanastomotic strictures (NAS) without underlying hepatic artery thrombosis are commonly referred to as ischemic-type biliary lesions (ITBL).

Risk factors for ITBL include preservation-induced injury, prolonged cold and warm ischemia times, altered bile composition, ABO blood incompatibility and immunological injury (Verdonk 2007, Buis 2009).

Endoscopic retrograde cholangiography (ERC) or percutaneous transhepatic cholangiography (PTC) have typically been used as the primary approach, leaving surgical intervention for those who are nonresponsive to endoscopic interventions or who have diffuse intrahepatic bile duct damage. Novel radiological methods such as magnetic resonance cholangiopancreatography (MRCP) have been introduced as an additional diagnostic tool for biliary complications.

The long-term efficacy and safety of endoscopic techniques have been evaluated in various transplant centers (Qin 2006, Zoepf 2006, Pascher 2005). Nonanastomotic strictures are commonly associated with a less favourable response to interventional endoscopic therapy in comparison to anastomosis stenosis (Figure 5). An Austrian group found anastomotic strictures in 12.6% of patients transplanted

between October 1992 and December 2003 and nonanastomotic strictures in 3.7% during a mean follow-up of 53.7 months after LT (Graziadei 2006). Interventional endoscopic procedures were effective in 77% of patients with anastomosis stenosis; whereas treatment of nonanastomotic strictures showed long-term effectiveness in 63% of patients. A surgical approach was required in 7.4% of transplant recipients.



**Figure 5. Biliary tract complications after liver transplantation.** A. Endoscopic retrograde cholangiography (ERC) showing post-transplant short filiform anastomotic biliary stricture in a 46-year-old patient transplanted for HCV and alcohol-related cirrhosis 6 months earlier. Therapy sessions include dilatation and an increasing number of bile duct endoprotheses at short intervals of every 2-3 months. Prior to endoscopic therapy an endoscopic sphincterotomy is performed. B. ERC of a 41-year-old patient transplanted for HCV diagnosed with ischemic-type biliary lesions (type 3) with long nonanastomotic stricture extending proximally from the site of the anastomosis and strictures throughout the entire liver.

Zoepf et al. (2006) retrospectively analyzed results from 75 transplanted patients undergoing ERC for suspected anastomotic strictures. Balloon dilatation alone and combined dilatation and endoprotheses placement was efficacious in 89% and 87% of cases respectively, but recurrence occurred in 62% and 31% of cases respectively. We therefore use dilatation plus stenting with endoscopic reassessment in anastomotic strictures. Repeated ERC sessions are performed with increasing endoprothesis diameter in trimonthly time intervals and double or triple parallel stenting in selected cases. Up to 75% of patients are stent-free after 18 months of endoscopic intervention (Tung 1999).

Medical treatment for bile duct strictures consists of UDCA and additional antibiotic treatment in stricture-induced cholangitis. Complications related to bilioenteric anastomosis require PTC or surgical intervention.

## Metabolic bone disease

Liver cirrhosis and therapy with corticosteroids are risk factors for the development of osteoporosis. Screening with bone densitometry should therefore begin prior to LT (Wibaux 2011). A further increase in bone turnover has been described after LT and may be associated with resolution of cholestasis, increased parathormone secretion and/or CNI administration (Moreira Kulak 2010). Metabolic bone disease

is therefore a common cause of morbidity after LT. Factors such as vitamin D deficiency, hypogonadism, secondary hyperparathyroidism and adverse lifestyle factors should be addressed and corrected. There are no specific therapies for post-transplant osteoporosis other than for nontransplanted patients. General interventions to reduce fracture risk include adequate intake of calcium and vitamin D. Bisphosphonates are currently the most effective agents for treatment of post-transplant osteoporosis (Moreira Kulak 2010) ([www.dv-osteologie.org](http://www.dv-osteologie.org)). A meta-analysis and systematic review of randomised controlled trials demonstrated that bisphosphonate therapy within the first 12 months after LT is associated with reduced accelerated bone loss and improved bone mineral density at the lumbar spine (Kasturi 2010).

## Recurrent diseases after liver transplantation

Disease recurrence may occur in patients transplanted for viral hepatitis, tumor disease, autoimmune or cholestatic or alcohol-related liver diseases. With universal recurrence of HCV in all replicative patients, hepatitis C continues to pose one of the greatest challenges for preventing disease progression in the allograft.

### Recurrence of hepatitis B in the allograft

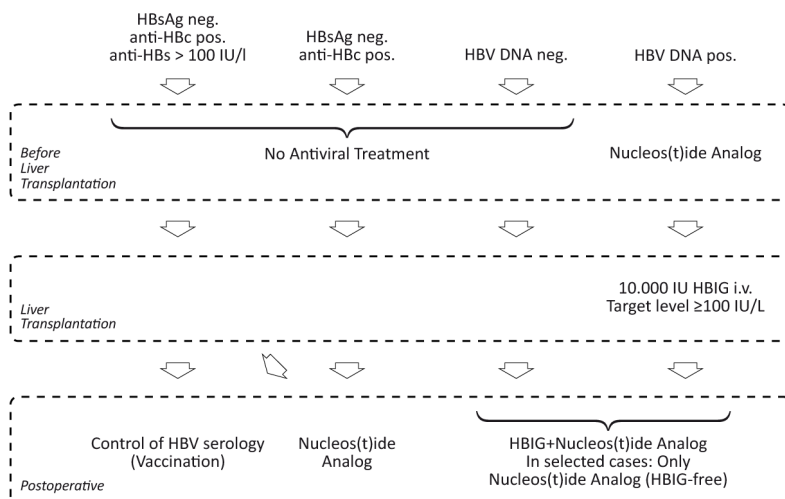
Combined use of hepatitis B immunoglobulin (HBIG) and nucleos(t)ide analogs has emerged as treatment of choice in transplant HBV recipients (Figure 6) (Yan 2006, Marzano 2005, Cai 2011) and its efficacy has been investigated extensively. HBV recurrence using combined prophylactic regimens is less than 5%. However, recurrence rates differ among various studies as most of them are small, with varying proportions of patients with active viral replication at LT and varying follow-up periods after LT. Furthermore there is a high variability (dose, duration and method of HBIG administration) in the prophylactic protocols. According to the German guidelines (Cornberg 2011) patients receive 10,000 IU HBIG intravenously (IV) in the anhepatic phase followed by 2000 IU during the first posttransplant week. For long-term HBIG prophylaxis, trough anti-HBs levels at or above 100 IU/L should be maintained. Subcutaneous (SC) HBIG application has various advantages over intramuscular (IM) and IV administration (Beckebaum 2008b, Yahyazadeh 2011) and can be administered in stable and compliant patients after the early post-transplant period. It is well tolerated and patients can perform injections in a home setting, thus reducing physician consultation time. Nucleos(t)ide analogs given prior to LT should be continued indefinitely post-transplant.

Economic issues have led to a controversial discussion of whether indefinite passive immunisation is necessary and if nucleos(t)ide analog therapy is sufficient for antiviral prophylaxis (Naoumov 2001, Buti 2007, Gane 2007, Angus 2007, Neff 2007, Lo 2005, Wong 2007, Nath 2006, Yoshida 2007, Weber 2010, Karlas 2011).

Post-transplant studies have described unacceptable 2-4 year rejection rates of approximately 25-50% with LAM monotherapy and with no initial phase of HBIG therapy (Table 5) (see <http://hepatologytextbook.com/link.php?id=9>) (Marzano 2001, Jiao 2007, Zheng 2006).

A prospective, open-label, multicenter study was conducted on the safety and efficacy of combined LAM/ADV therapy in HBsAg-positive LT recipients (Gane 2007) (Table 5) (see <http://hepatologytextbook.com/link.php?id=9>). Patients with

clinical and virologic LAM resistance were excluded. Combined nucleos(t)ide analog treatment started upon wait-listing. The median duration of antiviral therapy prior to LT was 3.6 months. HBIG (800 IU IM) was administered for only one week post-transplant. During the study, 19 patients were transplanted, and of those, none had recurrent HBV during a median follow-up of 11.7 months.



**Figure 6. Prophylaxis of HBV recurrence after liver transplantation (LT).** Combined use of nucleos(t)ide analog(s) and hepatitis B immunoglobulin (HBIG) is the current gold standard for prophylaxis of HBV reinfection after LT. HBIG therapy can be withdrawn in the long term after LT in selected low-risk (HbsAg-negative) cases. Those who are anti-hepatitis B core (anti-HBc)-positive and without detectable anti-hepatitis B surface (anti-HBs) titers or anti-HBs titers <100 IU/L should be vaccinated according to the German Guidelines (Cornberg 2011). In case of no or little response (anti-HBs <100 IU/L) to vaccination, lamivudine (LAM) monotherapy can be initiated. In patients who have protective anti-HBs titers of >100 IU/L, antiviral therapy is not necessary but long-term monitoring of HBV serology including anti-HBs titers is required. Neg., negative; pos., positive.

The same group conducted a study comparing patients who were switched from HBIG/LAM to LAM/ADV versus those who maintained on HBIG/LAM therapy (Table 5) (see <http://hepatologytextbook.com/link.php?id=9>) (Angus 2007). One patient in the switch group became HBsAg-positive, but remained HBV DNA-negative after 5 months; all others remained HBsAg- and HBV DNA-negative at a median of 17.2 months from randomization.

In another study, sixteen patients with LAM resistance who had treatment at LT with LAM plus ADV therapy were investigated (Lo 2005). Half of the patients were administered HBIG for a median of 24 months. None of them had detectable HBV DNA, 13 were HBsAg-negative, and 2 without combined HBIG therapy maintained HBsAg-positive after a follow-up period of 7.7 and 9.5 months, respectively.

A small cohort of non-HBV replicating patients who were switched from HBIG/LAM (150 mg/d) to ADV (5 mg/d)/LAM (150 mg/d) therapy after a mean post-LT period of 6.5 months was retrospectively investigated (Neff 2007) (Table 5)

(see <http://hepatologytextbook.com/link.php?id=9>). The mean length of follow-up from therapy switch was 21 months. They found that none of the patients showed an increase in transaminases while on dual nucleos(t)ide analog therapy. Although the authors mentioned that HBV serologic testing was performed, no results were given post-therapy switch.

In a recently published study from Hong Kong, HBIG-free monoprophylaxis with ETV was evaluated. Only 26% of patients had undetectable HBV DNA at the time of LT. HBsAg loss occurred in 91% within 2 years post-transplant but 13% had reappearance of HBsAg and 22.5% were HBsAg-positive at the time of their last follow-up visit (Fung 2011).

The efficacy of a switch after at least 12 months of HBIG/LAM to combination therapy with an oral nucleoside and nucleotide analog was investigated (Saab 2011). Estimated HBV reinfection rate was 1.7% at 1 year after HBIG withdrawal.

HBV prophylactic postransplant studies to date are limited, small and with short follow-up periods (Table 5) (see <http://hepatologytextbook.com/link.php?id=9>). Larger prospective studies are needed to show if nucleos(t)ide analogs can be safely applied in the majority of HBV transplant patients against recurrent hepatitis B infection. Presently, withdrawal of HBIG prophylaxis and maintenance with nucleos(t)ide analog therapy can be considered in stable HBsAg-negative patients in the long term post-LT.

There is no rationale for continuing HBIG therapy in case of viral breakthrough with detectable HBV DNA. The choice of antiviral therapy in patients with HBV recurrence depends on the current antiviral medication, the viral load, and the resistance profile. Antiviral drug resistance can easily be established by genotypic assays that identify specific mutations known to be associated with decreased susceptibility to particular drugs.

## Recurrence of hepatitis C in the allograft

The influence of HCV infection on allograft histology is highly variable. The liver injury can vary from absent or mild disease despite high viral burden to cirrhosis in the allograft (approximately 20-30% of recipients within 5-10 years of follow-up) (Rubin 2011). Patient and graft survival in HCV-infected transplant recipients is worse compared to those with other indications (Berenguer 2007, Forman 2002, Testa 2000). After a diagnosis of cirrhosis, the decompensation risk appears to be accelerated (17% and 42% at 6 and 12 months, respectively) (Berenguer 2000) and patient survival is significantly decreased (66% and 30% at 1 and 5 years, respectively) (Saab 2005). Female gender has been reported as a risk factor for advanced recurrent HCV disease and graft loss after LT (Lai 2011). Several other factors have been suggested that may accelerate HCV reinfection of the allograft (Belli 2007, Berenguer 2003, Iacob 2007, Saab 2005) (Table 6).

There are insufficient and somewhat controversial data regarding the relationship between immunosuppressive agents and clinical expression of HCV recurrence (Table 7) (Berenguer 2011). TAC and CSA do not seem to be significantly different (Berenguer 2006a, Lake 2003, Martin 2004, Berenguer 2011) with respect to their impact on the course of hepatitis C recurrence. Results from the multicenter ReViS-TC cohort study, conducted in 14 Spanish liver centres, revealed that CSA-based immunosuppression regimens may be advantageous against viral relapse after

antiviral therapy as compared to TAC-based immunosuppression (ReViS-TC Study Group 2011).

**Table 6. Factors that may accelerate histological progression in HCV patients after liver transplantation.**

Donor factors	Recipient factors
Age	Surgical factors (cold/warm ischemia time)
Liver graft steatosis	Age
	Gender
	Non-caucasian race
	High viral load pre-transplant/early post-transplant
	Genotype 1b
	Muromonab-CD3 (OKT3®)
	Bolus corticosteroids
	Rapid tapering of corticosteroids

Various studies have demonstrated that slowly tapering corticosteroids over time may prevent progression to severe forms of recurrent disease (Brillanti 2002, McCaughan 2003).

Induction with MMF has been associated with more severe recurrence of HCV (Berenguer 2003). Other investigators have found that MMF has no impact on patient survival, rejection, or rate of viral recurrence in HCV-infected transplant recipients based on biochemical changes and histological findings (Jain 2002). In a recent systematic review, recurrent HCV was less severe in 5/9 studies with AZA compared with 2/17 with MMF (Germani 2009). Significantly better patient survival and graft survival was shown for HCV-infected patients treated with MMF, TAC, and steroids than for patients treated only with TAC and steroids, with 4-year patient survival rates of 79.5% vs. 73.8% and 4-year graft survival rates of 74.9% vs. 69.5% (Wiesner 2005). MMF in combination with a CNI taper for 24 months had a positive effect on fibrosis progression, graft inflammation, and alanine aminotransferase levels (Bahra 2005). This may be due to the antifibrotic effects of MMF through an antiproliferative effect on myofibroblast-like cells.

Interleukin-2 receptor inhibition can be safely used in HCV transplanted patients (Togashi 2011, Klintmalm 2007, Calmus 2002) while OKT3 has shown to increase severity of HCV recurrence resulting in impaired patient and allograft survival (Rosen 1997).

Sufficient data from randomised controlled studies in HCV patients are lacking with respect to the role of mTOR inhibitors in patients and graft outcome (Samonakis 2005, Schacherer 2007, Asthana 2011). Results of one study suggest that *de novo* SRL-based immunosuppression does not significantly affect the severity of HCV recurrence (Asthana 2011). A lower fibrosis extent and rate of progression was found among HCV transplant recipients with SRL as primary immunosuppression as compared to controls with an SRL-free immunosuppressive regimen (McKenna 2011).

**Table 7. Factors that may accelerate histological progression in HCV patients after liver transplantation.**

Immunosuppressive agent	Severity of HCV recurrence
Calcineurin inhibitors	No difference between cyclosporin A and tacrolimus
Bolus corticosteroids	Higher risk of fibrosis progression, increase in viral load
Azathioprine	Controversial debate
Mycophenolate mofetil	Controversial debate
Monoclonal CD3-antibodies (OKT3)	Increased risk of graft failure
Interleukin-2 receptor antibodies	No disadvantage on graft survival
mTOR inhibitors	Controversial (reduction of vs. no impact on fibrosis progression)

Regular histological evaluation of post-transplant chronic hepatitis C in 1-year (or maximum 2-year) intervals is recommendable to determine the grade of inflammation and stage of fibrosis. In particular, the biopsy result is important for therapy decision, to exclude signs of rejection prior to antiviral therapy and to determine the efficacy of antiviral therapy. In addition, there are some published as well as ongoing studies evaluating the role of non-invasive measurement of fibrosis in HCV and non-HCV transplant recipients (Cross 2011, Beckebaum 2010).

IFN  $\alpha$  and RBV therapy may prevent the development of HCV graft cirrhosis (Hashemi 2011, Gordon 2009, Cicinnati 2007b). This treatment is however associated with more side effects and is far less effective than in the non-transplant setting. The most applicable treatment strategy is treatment of established HCV recurrence with PEG-IFN  $\alpha$  and ribavirin, which results in an SVR of 20-30% (Gordon 2009). Preemptive antiviral therapy (Shergill 2005, Sugawara 2004, Chalasani 2005, Bzowej 2011) has not shown superior effects as compared to established HCV therapy (Berenguer 2008, Chalasani 2005, Bizollon 2005, Castells 2005, Toniutto 2005) and should only be considered in cases of rapid progression of HCV infection in the early post-transplant period. Most published studies in the transplant setting are not controlled, monocentric and/or comprise a small patient cohort (Shergill 2005, Sugawara 2004, Gane 1998, Kizilisik 1997, Ghalib 2000).

Recently published results indicate that RBV pre-treatment increased the tolerability of the antiviral treatment, and improved its efficacy in LT patients (Merli 2011).

The NS3/4 protease inhibitors telaprevir and boceprevir are metabolized primarily by the cytochrome P450 CYP3A4. Coadministration with CNI metabolised primarily by CYP3A4 has shown to result in increased dose-normalized CSA and TAC exposure by ~4.6-fold and ~70-fold (Garg 2011).

Optimal onset, dose and duration of therapy are not known yet. Positive predictive factors for SVR include use of erythropoietin, patient compliance, treatment with PEG-IFN (versus standard IFN) and an early histological response (Berenguer 2006b).

The proportion of patients who need a dose reduction of their antiviral therapy due to anemia or leucopenia may be reduced by the use of erythropoietin or granulocyte-macrophage colony-stimulating factor (not approved for this indication). Reported risk of rejection is low if antiviral therapy is closely monitored

(Gane 1998, Kizilisik 1997). Therapy needs to be withdrawn in case of significant histologically-proven rejection.

## Recurrence of cholestatic liver diseases and autoimmune hepatitis

Data about the frequency of recurrent cholestatic and AIH-related liver disease vary in the literature depending on the follow-up period and criteria chosen for definition of disease recurrence.

The post-transplant prognosis for PBC patients is excellent, with an approximately 80% 5-year survival reported by most large centres (Carbone 2011, Silveira 2010). It has been reported that HLA-A, -B, and -DR mismatches between the donor and the recipient decrease the risk of disease recurrence in PBC patients (Morioka 2007a, Hashimoto 2001). A recently published study reported recurrent PBC in one-third of patients at 11-13 years post-transplant (Charatcharoenwithaya 2007). Various other studies reporting recurrent PBC are depicted in Table 8 (Jakob 2006, Liermann-Garcia 2001, Montano-Loza 2010, Hytioglou 2008).

**Table 8. Recurrence rates in patients transplanted for autoimmune-related or cholestatic liver disease.**

Reference	Patients, n	Follow-up after liver transplantation	Recurrence rate
AIH Duclos-Vallée 2003	17	>120 months	41%
AIH Prados 1998	27	mean 44 months	33%
AIH Molmenti 2002	55	median 29 months	20%
AIH Campsen 2008	66	median 81 months	36%
AIH Vogel 2004	28	mean 100 months	32%
PBC Charatcharoenwithaya 2007	154	mean 130 months	34%
PBC Jakob 2006	100	up to 17 years	16%
PBC Liermann-Garcia 2001	400	mean 56 months	17%
PBC Montano-Loza 2010	108	mean 88 months	26%
PBC Hytioglou 2008	100	mean 44 months	16%
PSC Cholongitas 2008	69	median 110 months	13%
PSC Alabraba 2009	230	median 55 months	24%
PSC Vera 2002	152	median 36 months	37%
PSC Graziadei 1999	150	mean 54 months	20%
PSC Goss 1997	127	mean 36 months	9%

Diagnosis of PBC in the transplanted liver is usually more challenging than diagnosis in the native liver. Immunoglobulin M and anti-mitochondrial antibodies (AMA) often persist, and elevated cholestatic enzymes may be due to other causes of bile duct damage such as ischemic cholangiopathy or chronic ductopenic rejection. Recurrent PBC is a histological diagnosis, typically appearing as granulomatous cholangitis or duct lesions. The frequency of recurrence will be considerably underestimated if a liver biopsy is carried out only when clinical features are apparent.

Some investigators have found that CSA-based immunosuppressive therapy is associated with lower PBC recurrence rates as compared to TAC-based



immunosuppression (Wong 1993, Montano-Loza 2010). However, long-term survival has been shown to be not significantly different between CSA- and TAC-treated patients (Silveira 2010). The impact of UDCA on the natural history of recurrent disease remains unknown. In the Mayo Clinic transplant cohort, 50% of recurrent PBC patients receiving UDCA showed normalization of serum alkaline phosphatase and alanine aminotransferase levels over a 36-month period compared with 22% of untreated patients (Charatcharoenwittaya 2007). Although no significant differences in the rate of histological progression could be detected between the treated and untreated subgroups, the proportion of individuals with histological progression was significantly lower in those that showed improvement of biochemical parameters regardless of treatment.

The reported recurrence rate for PSC after LT ranges between 9% and 37% (Cholongitas 2008, Alabraba 2009, Vera 2002, Graziadei 1999, Goss 1997). A British liver transplant group found significantly better recurrence-free survival rates in patients who underwent colectomy before or during LT and in those with non-extended donor criteria allografts (Alabraba 2009).

Recurrent PSC is diagnosed by histology and/or imaging of the biliary tree and exclusion of other causes of nonanastomotic biliary strictures. Histopathological findings in PSC include fibrous cholangitis, fibro-obliterative lesions, ductopenia, and biliary fibrosis. In a study conducted by the Mayo clinic, recurrence of PSC was defined by strict cholangiographic and histological criteria in patients with PSC, in whom other causes of bile duct strictures were absent (Graziadei 2002). However, due to the lack of a histological gold standard, the diagnosis of PSC recurrence is based primarily on cholangiographic features. Due to its responsiveness to steroid therapy, IgG4-associated cholangitis instead of suspected or recurrent PSC should be considered in patients with atypical features including history of pancreatitis.

Interestingly, despite immunosuppression, a significantly higher corticosteroid requirement was reported in the transplant as compared to the nontransplant setting, with 20% of PSC patients becoming corticosteroid dependent after LT (Ho 2005). A recent study reported that maintenance steroids (>3 months) for ulcerative colitis post-LT were a risk factor for recurrent PSC (Cholongitas 2008).

AIH recurrence has been reported in about one-third of patients within a post-transplant follow-up period of  $\geq 5$  years (Mendes 2011, Tripathi 2009, Duclos-Vallee 2003, Campsen 2008, Vogel 2004). Incidence increases over time as immunosuppression is reduced (Prados 1998). A long-term follow-up study (>10 years) by a French group found AIH recurrence in 41% of the patients. The authors recommended regular liver biopsies, because histological signs precede abnormal biochemical liver values in about one-fourth of patients (Duclos-Vallee 2003). The diagnosis of recurrent AIH may include histological features, the presence of autoantibodies, and increased gamma globulins. The majority of published studies did not confirm a post-transplant prognostic role of antibodies in patients undergoing LT for AIH. Conflicting data exist regarding the presence of specific HLA antigens that predispose patients to AIH recurrence after LT (Gonzalez-Koch 2001, Molmenti 2002). Histological signs of recurrence include interface hepatitis, lymphoplasmacytic infiltration, and/or lobular involvement. In an analysis of data from 28 patients with AIH, 5-year survival rate was not significantly different from controls with genetic liver diseases (Vogel 2004). Patients had more episodes of acute rejection though, in comparison to the control group.

Patients with AIH typically receive low-dose steroid therapy after LT. The transplant centre in Colorado that found that recurrence was not strongly influenced by steroid withdrawal in their cohort attempts to minimise or stop steroid therapy in AIH transplant patients (Campsen 2008).

## **Outcome in patients transplanted for hepatic malignancies**

The results of early studies of LT for HCC were disappointing. More than 60% of patients developed tumor recurrence within the first two transplant years (Ringe 1989). Currently, there are recurrence rates of 10-15% in patients fulfilling the Milan criteria (Zavaglia 2005). In an analysis of predictors of survival and tumor-free survival in a cohort of 155 HCC LT recipients, histological grade of differentiation and macroscopic vascular invasion were identified as independent predictors of survival and tumor recurrence (Zavaglia 2005). Others identified MELD score >22, AFP >400 ng/mL and age >60 years as negative predictors for survival in HCC (Sotiropoulos 2008b, Jelic 2010). For patients having an indication for LT despite exceeding the Milan criteria, the use of marginal grafts or performance of LDLT has been considered as a reasonable option.

Expansion beyond the Milan criteria to University of California San Francisco (UCSF) criteria (single tumour <6.5 cm; two to three tumours, none >4.5 cm or total diameter <8 cm, no vascular invasion) or even more liberal criteria (no portal invasion, no extrahepatic disease) have been discussed widely (Sotiropoulos 2007, Silva 2011, Jelic 2010). Centers such as the San Francisco Transplant Group as well as the UCLA Transplant Group have demonstrated 5-year survival rates of 50-80% after LT for tumours beyond the Milan criteria but within UCSF criteria (Duffy 2007, Yao 2007).

Recently, the 'up to seven' criteria (with 7 being the sum of the size and number of tumors for any given HCC) were suggested as an approach to include additional HCC patients as transplant candidates. However, acceptance of a more liberal organ allocation policy would result in a further increase of HCC patients on the waiting list and in denying the use of these organs to other non-HCC patients.

Expansion of criteria in the LDLT setting is even more challenging due to the donor risk and the risk of selection of tumours with unfavorable biology following the concept of fast-tracking (Hiatt 2005). Novel molecular biology techniques, such as genotyping for HCC, may become relevant for determining recurrence-free survival and improving patient selection but these biomarkers can not yet be used for clinical decision making.

Recently, a satisfactory outcome and potential survival benefit were reported in studies and a meta-analysis of controlled clinical trials with SRL-based immunosuppression in patients transplanted for HCC (Kneteman 2004, Zimmerman 2008, Toso 2007, Liang 2011). These results are in line with a retrospective analysis based on the Scientific Registry of US Transplant Recipients, which included 2491 HCC LT recipients and 12,167 recipients with non-HCC diagnoses. Moreover, the SILVER Study, a large prospective randomized controlled trial, comparing SRL-containing versus SRL-free immunosuppression will provide further results and details with respect to the impact of SRL on HCC tumour recurrence (Schnitzbauer 2010b).

Neoadjuvant chemoradiation and subsequent LT has shown promising results for patients with localized, unresectable hilar cholangiocellular carcinoma (CCC) (Rea

2005, Masuoka 2011). In a recently published US study, outcome of 38 patients who underwent LT was compared to that of 19 patients who underwent combined radical bile duct resection with partial hepatectomy (Hong 2011). Tumor was located in intrahepatic bile duct in 37 patients and in hilar bile duct in 20 patients. Results demonstrated that LT combined with neoadjuvant and adjuvant therapies is superior to partial hepatectomy with adjuvant therapy. Challenges of LT attributable to neoadjuvant therapy include tissue injury from radiation therapy and vascular complications that include hepatic artery thrombosis. Predictors of response to the neoadjuvant protocol prior to LT need to be determined (Heimbach 2008). Increasing age, high pretransplant tumor marker, residual tumour size in the explant >2 cm, tumour grade, previous cholecystectomy and perineural invasion were identified as predictors of recurrence following LT (Knight 2007).

Metastatic lesions originating from neuroendocrine tumours (NET) may be hormone-producing (peptide hormones or amines) or may present as nonfunctional tumours (Frilling 2006, Lehnert 1998). They are characterized by slow growth and frequent metastasis to the liver, and their spread may be limited to the liver for protracted periods of time. Most studies in patients transplanted for NET are limited and usually restricted to small numbers of patients. A recently published analysis based on the UNOS database including patients transplanted for NET between October 1988 and January 2008, showed that long-term survival of NET patients was similar to that of patients with HCC. Excellent results can be obtained in highly selected patients and a waiting time for LT longer than 2 months (Gedaly 2011). Long-term results from prospective studies are needed to further define selection criteria for patients with NET for LT, to identify predictors for disease recurrence, and to determine the influence of the primary tumour site on patient post-transplant survival.

## **Recurrent alcohol abuse after liver transplantation for alcoholic liver disease**

Alcoholic liver disease has become a leading indication of LT in Europe and the United States. Patient and graft survival is excellent in those maintaining alcohol abstinence after LT. Severe chronic alcohol consumption after LT significantly decreases the medium- and long-term survival (Pfitzmann 2007). A recent study has shown that urine ethyl glucuronide is a reliable marker for detection of alcohol relapse after LT (Staufner 2011). Studies evaluating recurrent alcohol use have reported a mean incidence of relapse in one-third of patients ranging from 10% to 50% in up to 5 years of follow-up (Burra 2005).

According to results from the European Liver Transplant Registry (ELTR), mortality and graft failure were more often related to *de novo* tumors, cardiovascular and social factors in alcoholic LT patients as compared to patients transplanted for other etiologies (Burra 2010). The role of the length of pre-transplant abstinence as a predictor of post-transplant abstinence has been widely discussed. Many studies have assessed possible risk factors for alcoholic relapse after LT. The following factors have been identified as risks for recurrent alcohol abuse: a shorter length of abstinence before LT, more than one pretransplant alcohol withdrawal, alcohol abuse in first relatives, younger age, and alcohol dependence (Perney 2005). Accordingly, the results from the Pittsburgh Transplant Center revealed that the prognosis regarding continued abstinence post-transplant is much

more favourable for individuals with a diagnosis of overconsumption (abuse) than for those who meet criteria for alcohol dependence (DiMartini 2008).

A recently published study reported that poorer social support, family alcohol history, and pretransplant abstinence of  $\leq 6$  months showed significant associations with relapse (Dew 2008). In addition, an Australian study identified the presence of psychiatric comorbidities, or a score higher than 3 on the High-Risk Alcoholism Relapse (HRAR) scale as factors predictive of relapse into harmful drinking (Haber 2007).

## **Experiences with liver transplantation in inherited metabolic liver diseases in adult patients**

LT is regarded as an effective treatment strategy for patients with Wilson's Disease which presents as deterioration of cirrhosis not responsive to treatment, as acute on chronic disease or fulminant hepatic failure (Moini 2010). LT reverses the abnormalities of copper metabolism by converting the copper kinetics from a homozygous to a heterozygous phenotype, thus providing an adequate increase of ceruloplasmin levels and a decrease of urinary copper excretion post-transplant. The King's College Hospital reported excellent long-term results after LT in patients who have undergone LT for Wilson's Disease since 1994 with 5-year patient and graft survival rates of 87.5% (Sutcliffe 2003). There are several reports in the literature indicating a reversal of neurological symptoms after LT (Martin 2008). However, the course of neurological symptoms remains unpredictable and it is still a matter of debate if LT should be considered in patients with severe neurological impairment (Pabón 2008).

Alpha-1-antitrypsin (AAT) deficiency is a common genetic reason for pediatric LT, but a rare indication in adults. The Z allele is most commonly responsible for severe deficiency and disease. LT corrects the liver disease and provides complete replacement of serum AAT activity. 567 AAT recipients who underwent LT between 1995 and 2004 were retrospectively investigated (Kemmer 2008). Results based on UNOS data revealed 1-, 3-, and 5-year patient survival rates of 89%, 85%, and 83%, respectively.

In hemochromatosis, iron depletion therapy prior to LT may be associated with a better outcome after LT and is therefore strongly recommended (Weiss 2007). It has been reported that the survival of patients who undergo LT for hereditary hemochromatosis is markedly lower in comparison to other indications (Dar 2009, Brandhagen 2001). Reduced post-transplant survival in patients with hemochromatosis has been attributed to cardiac problems and increased infectious complications. Findings derived from the UNOS database revealed 1-year and 5-year survival rates of 75% and 64% in patients with iron overload, as compared to 83% and 70% in those without iron overload (Brandhagen 2001). More recent results from patients with hemochromatosis ( $n=217$ ) transplanted between 1997-2006 revealed excellent 1-year (86.1%), 3-year (80.8%), and 5-year (77.3%) patient survival rates, which were not different from those transplanted for other liver diseases (Yu 2007).

## Outcome after liver transplantation for acute hepatic failure

Acute hepatic failure (AHF) accounts for 5-12% of LT activity worldwide. Drug-induced liver injury due to acetaminophen overdose is the most common cause of LT for acute liver failure in developed countries (Craig 2010, Au 2011). Other etiologies comprise idiosyncratic drugs (such as isoniazid/rifampicin, coumarins, acetaminophen, ecstasy, tricyclic antidepressants), Budd-Chiari syndrome, Wilson's Disease, hepatitis A, B and E infection or autoimmune disease.

Patients with acute fulminant liver disease should be transferred to an ICU at a medical centre experienced in managing AHF, with LT capabilities. Bioartificial hepatic devices may serve as bridging therapy to native liver recovery or to LT.

Early postoperative complications in patients transplanted for AHF include sepsis, multisystem organ failure, and primary graft failure. Serum creatinine concentrations above 200  $\mu\text{mol/L}$  pretransplant, non-white race of the recipient, donor body mass index  $>35 \text{ kg/m}^2$  and recipient age  $>50$  years have been suggested as risk factors for post-transplant mortality (Wigg 2005). Others reported that extended donor criteria rates and severe cerebral edema were associated with worse outcome (Chan 2009). The Edinburgh LT centre investigated the impact of perioperative renal dysfunction on post-transplant renal outcomes in AHF patients. They found that older age, female gender, hypertension, CSA and non-acetaminophen-induced AHF but not the severity of perioperative renal injury were predictive for the development of chronic kidney injury (Leithead 2011).

The results in patients transplanted for AHF have improved within the last decade due to the establishment of prognostic models, improved intensive care management and the option for LDLT which has a limited role in the US and Europe but plays a major role in Asia (Lo 2008). AHF was the indication for LDLT in more than 10% of the cohort reported by two Asian groups (Morioka 2007b, Lo 2004).

Available data document that survival in patients with AHF is inferior to that of recipients with nonacute indications for LT within the first year but comparable in the long-term (Chan 2009, Wigg 2005).

## Conclusion

LT is challenging due to a shortage of organs and a prolonged waiting-list time. The large disparity between the number of available cadaver donor organs and recipients awaiting LT has created an ongoing debate regarding the appropriate selection criteria. The rationale of allocation systems utilizing the MELD score is to prioritize patients with severe liver dysfunction ("the sickest first"). This results in decreased waiting list mortality from 20 to 10% in the Eurotransplant region but also in a reduction of 1-year post-transplant survival by approximately 10%. A potential modification of the MELD allocation system or rather development of an improved prognostic scoring system incorporating donor-related factors, pretransplant mortality and post-transplant outcome is urgently warranted to optimize organ allocation in the future.

Due to the availability of antiviral drugs, the survival of patients undergoing LT for HBV infection has dramatically improved and has become comparable to or even better than the survival of patients with non-virus-related liver diseases. HBIG-

free therapeutic regimens with new promising nucleos(t)ide analog combinations are currently being investigated for their efficacy and safety as first-line therapy in clinical studies.

HCV has become a leading indication for LT in Europe and the United States. There is ongoing research aiming to define host or viral factors that predict recurrence, the impact of immunosuppressive regimens, and the appropriate timepoint and dosing for combined PEG-IFN and RBV therapy. The overall risk and benefit of new antiviral treatment strategies including protease inhibitors remain to be evaluated.

Data about the frequency of disease recurrence in cholestatic and autoimmune liver diseases vary in the literature. Diagnosis of disease relapse in cholestatic and autoimmune liver disease is more challenging than in the non-transplant setting. Most studies report excellent medium-term and long-term results despite limited therapeutic options for disease recurrence.

LT in HCC patients provides excellent outcomes and low recurrence rates following the Milan criteria. Expansion of transplantation criteria beyond the Milan criteria has been discussed at length. The acceptance of a more liberal organ allocation policy may result in a further increase of the proportion of patients transplanted for HCC and denying the use of these organs to other patients for whom better results may be achieved. Recent developments in genomic and proteomic approaches may allow the identification of new biomarkers for prediction of HCC recurrence.

Non-use of alcohol of  $\geq 6$  months pretransplant is widely considered the prerequisite time for listing for LT. There are few reliable predictors of relapse in alcoholic patients after LT. Survival rates in patients with alcohol-related liver disease are similar or even better when compared to the outcomes of patients who undergo transplant for other types of chronic liver disease. In contrast, survival is worse in patients with heavy alcohol consumption after LT.

The management of cardiovascular, renal, coagulopathic, cerebral and infectious complications in patients with AHF is clinically challenging. Prognostic models are helpful but not entirely accurate in predicting those who will require LT. Due to advances in intensive care medicine and surgical techniques, outcomes for patients with AHF have progressively improved during the last 2 decades.

Much attention has been directed to reducing CNI-associated long-term complications. Cardiovascular comorbidities due to metabolic complications such as diabetes mellitus, dyslipidemia, obesity, and arterial hypertension account for 30-70% of long-term morbidity. Current trends of immunosuppressive strategies include CNI-sparing/-free protocols including MMF- and/or mTOR-based immunosuppressive regimens and corticosteroid-avoidance protocols. CNI delay with induction therapy for bridging the early postoperative phase should be considered especially in patients with high MELD scores. Finally, "individually tailored immunosuppressive" protocols may optimize drug efficacy, minimise drug toxicity and improve transplant outcome.

## References

- Afonso RC, Hidalgo R, Zurstrassen MP, et al. Impact of renal failure on liver transplantation survival. *Transplant Proc* 2008;40:808-10.
- Alabraba E, Nightingale P, Gunson B, et al. A re-evaluation of the risk factors for the recurrence of primary sclerosing cholangitis in liver allografts. *Liver Transpl* 2009;15:330-40.
- Andrews PA, Emery VC, Newstead C. Summary of the British Transplantation Society Guidelines for the Prevention and Management of CMV Disease After Solid Organ Transplantation. *Transplantation* 2011; [Epub ahead of print]
- Angus PW, Strasser SI, Patterson S, et al. A randomized study to assess the safety and efficacy of adefovir dipivoxil substitution for hepatitis B immune globulin in liver transplantation patients receiving long-term low dose IM HBIG and lamivudine prophylaxis. *Hepatology* 2007;46:238A.
- Asthana S, Toso C, Meeberg G, et al. The impact of sirolimus on hepatitis C recurrence after liver transplantation. *Can J Gastroenterol* 2011;25:28-34.
- Au JS, Navarro VJ, Rossi S. Drug-induced liver injury - its pathophysiology and evolving diagnostic tools. *Aliment Pharmacol Ther* 2011;34:11-20.
- Bahra M, Neumann UJ, Jacob D, et al. MMF and calcineurin taper in recurrent hepatitis C after liver transplantation: impact on histological course. *Am J Transplant* 2005;5:406-11.
- Bajjoka I, Hsaiky L, Brown K, Abouljoud M. Preserving renal function in liver transplant recipients with rabbit anti-thymocyte globulin and delayed initiation of calcineurin inhibitors. *Liver Transpl* 2008;14:66-72.
- Beavers KL, Sandler RS, Shrestha R. Donor morbidity associated with right lobectomy for living donor liver transplantation to adult recipients. *Liver Transpl* 2002;8:110-7.
- Beckebaum S (a), Cicinnati V, Brokalaki E, Frilling A, Gerken G, Broelsch CE. CNI-sparing regimens within the liver transplant setting: experiences of a single center. *Clin Transpl* 2004;215-20.
- Beckebaum S (b), Cicinnati VR, Broelsch CE. Future directions in immunosuppression. *Transplant Proc* 2004; 36:574S-6S.
- Beckebaum S, Cicinnati V, Gerken G. Current concepts for prophylaxis and treatment of hepatitis B reinfection after liver transplantation. *Med Klin (Munich)* 2008; 103:190-7.
- Beckebaum S, Sotiropoulos G, Gerken G, Cicinnati V. Hepatitis B and liver transplantation: 2008 update. *Rev Med Virol* 2009;19:7-29.
- Beckebaum S, Iacob S, Klein CG, et al. Assessment of allograft fibrosis by transient elastography and noninvasive biomarker scoring systems in liver transplant patients. *Transplantation* 2010;89:983-93.
- Beckebaum S, Cicinnati VR. Conversion to combined mycophenolate mofetil and low-dose calcineurin inhibitor therapy for renal dysfunction in liver transplant patients: never too late? *Dig Dis Sci* 2011;56:4-6.
- Becker T, Foltys D, Bilbao I, et al. Patient outcomes in two steroid-free regimens using tacrolimus monotherapy after daclizumab induction and tacrolimus with mycophenolate mofetil in liver transplantation. *Transplantation* 2008;86:1689-94.
- Belli LS, Burroughs AK, Burra P, et al. Liver Transplantation for HCV cirrhosis: improved survival in recent years and increased severity of recurrent disease in female recipients: results of a long term retrospective study. *Liver Transpl* 2007;13:737-40.
- Bellomo R, Ronco C, Kellum JA, Mehta RL, Palevsky P. Acute renal failure - definition, outcome measures, animal models, fluid therapy and information technology needs: the Second International Consensus Conference of the Acute Dialysis Quality Initiative (ADQI) Group. *Crit Care* 2004;8 R204-2.
- Benlloch S, Berenguer M, Prieto M, et al. De novo internal neoplasms after liver transplantation: increased risk and aggressive behavior in recent years? *Am J Transplant* 2004;4:596-604.
- Berenguer M, Prieto M, Rayon JM, et al. Natural history of clinically compensated HCV-related graft cirrhosis after liver transplantation. *Hepatology* 2000;32:852-8.
- Berenguer M, Crippin J, Gish R, et al. A model to predict severe HCV-related disease following liver transplantation. *Hepatology* 2003;38:34-41.
- Berenguer M (a), Aguilera V, Prieto M, et al. Effect of calcineurin inhibitors on survival and histologic disease severity in HCV-infected liver transplant recipients. *Liver Transpl* 2006;12:762-7.

- Berenguer M (b), Palau A, Fernandez A, et al. Efficacy, predictors of response, and potential risks associated with antiviral therapy in liver transplant recipients with recurrent hepatitis C. *Liver Transpl* 2006;12:1067-76.
- Berenguer M. Recurrent hepatitis C: worse outcomes established, interventions still inadequate. *Liver Transplantation* 2007;13:641-3.
- Berenguer M, Palau A, Aquilera V, Rayón JM, Juan FS, Prieto M. Clinical benefits of antiviral therapy in patients with recurrent hepatitis C following liver transplantation. *Am J Transplant* 2008;8:679-87.
- Berenguer M. Hot topic in hepatitis C virus research: The type of immunosuppression does not matter. *Liver Transplant* 2011;17:S24-S28.
- Bizzollon T, Ahmed SN, Radenne S, et al. Long term histological improvement and clearance of intrahepatic hepatitis C virus RNA following sustained viral response to interferon-ribavirin combination therapy in liver transplant patients with hepatitis C virus recurrence. *Gut* 2005;52:283-7.
- Brandhagen DJ. Liver transplantation for hereditary hemochromatosis. *Liver Transpl* 2001;7:663-7.
- Brillanti S, Vivarelli M, De Ruvo N, et al. Slowly tapering off steroids protects the graft against hepatitis C recurrence after liver transplantation. *Liver Transpl* 2002;8:884-8.
- Broelsch CE, Whitington PF, Emond JC, et al. Liver transplantation in children from living related donors. Surgical techniques and results. *Ann Surg* 1991;214:428-37.
- Buell JF, Gross TG, Woodle ES. Malignancy after transplantation. *Transplantation* 2005;15:S254-64.
- Buis CI, Geuken E, Visser DS, Kuipers F, Haagsma EB, Verkade HJ, et al. Altered bile composition after liver transplantation is associated with the development of nonanastomotic biliary strictures. *J Hepatol* 2009;50:69-79.
- Bundesärztekammer. Richtlinien zur Organtransplantation gem. §16 TPG. *Deutsches Ärzteblatt* 2008;105:A1461-4.
- Burra P, Lucey MR. Liver transplantation in alcoholic patients. *Transpl Int* 2005;18:491-8.
- Burra P, Senzolo M, Adam R, et al. Liver transplantation for alcoholic liver disease in Europe: a study from the ELTR (European Liver Transplant Registry). *Am J Transplant* 2010 Jan;10:138-48.
- Buti M, Mas A, Prieto M, et al. Adherence to lamivudine after an early withdrawal of hepatitis B immune globulin plays an important role in the long-term prevention of hepatitis B virus recurrence. *Transplantation* 2007;84:650-4.
- Bzowej N, Nelson DR, Terrault NA, et al. PHOENIX: A randomized controlled trial of peginterferon alfa-2a plus ribavirin as a prophylactic treatment after liver transplantation for hepatitis C virus. *Liver Transpl* 2011;17:528-38.
- Cai CJ, Lu MQ, Chen YH, Zhao H, Li MR, Chen GH. Clinical study on prevention of HBV re-infection by entecavir after liver transplantation. *Clin Transplant* 2011; doi: 10.1111/j.1399-0012.2011.01448.x.
- Cannon JA. *Organs*. *Transplant Bull* 1956;3-7.
- Calmus Y, Scheele JR, Gonzalez-Pinto I, et al. Immunoprophylaxis with basiliximab, a chimeric anti-interleukin-2 receptor monoclonal antibody, in combination with azathioprine-containing triple therapy in liver transplant recipients. *Liver Transpl* 2002;8:123-31.
- Campsen J, Zimmerman MA, Trotter JF, et al. Liver transplantation for autoimmune hepatitis and the success of aggressive corticosteroid withdrawal. *Liver Transpl* 2008;14:1281-6.
- Cantarovich M, Tzimas GN, Barkun J, Deschênes M, Alpert E, Tchervenkov J. Efficacy of mycophenolate mofetil combined with very low-dose cyclosporine microemulsion in long-term liver-transplant patients with renal dysfunction. *Transplantation* 2003;76:98-102.
- Carbone M, Neuberger J. Liver transplantation in PBC and PSC: indications and disease recurrence. *Clin Res Hepatol Gastroenterol* 2011;35:446-54.
- Castells L, Vargas V, Aleende H, et al. Combined treatment with pegylated interferon (alpha-2b) and ribavirin in the acute phase of hepatitis C virus recurrence after liver transplantation. *J Hepatol* 2005;43:53-9.
- Chalasani N, Manzarbeitia C, Ferenci P, et al. Peginterferon alfa-2a for hepatitis C after liver transplantation: two randomized, controlled trials. *Hepatology* 2005;41:289-98.
- Chan G, Taqi A, Marotta P, et al. Long-term outcomes of emergency liver transplantation for acute liver failure. *Liver Transpl*. 2009 Dec;15:1696-702.



- Charatcharoenwithaya P, Pimentel S, Talwalkar, et al. Long-term survival and impact of ursodeoxycholic acid treatment for recurrent primary biliary cirrhosis after liver transplantation. *Liver Transpl* 2007;13:1236-45.
- Choi PC, Kim HJ, Choi WH, et al. Model for end-stage liver disease, model for end-stage liver disease-sodium and Child-Turcotte-Pugh scores over time for the prediction of complications of liver cirrhosis. *Liver Int* 2009;29:221-6.
- Cholongitas E, Shusang V, Papatheodoridis GV, et al. Risk factors for recurrence of primary sclerosing cholangitis after liver transplantation. *Liver Transpl* 2008;14:138-43.
- Cicinnati VR (a), Yu Z, Klein CG, et al. Clinical trial: switch to combined mycophenolate mofetil and minimal dose calcineurin inhibitor in stable liver transplant patients-assessment of renal and allograft function, cardiovascular risk factors and immune monitoring. *Aliment Pharmacol Ther* 2007;26:1195-208.
- Cicinnati V (b), Iacob S, Klein C, et al. Ribavirin with either standard or pegylated interferon to treat recurrent hepatitis C after liver transplantation. *Aliment Pharmacol Ther* 2007;26:291-303.
- Cornberg M, Protzer U, Petersen J, et al. Prophylaxis, diagnosis and therapy of hepatitis B virus infection - the German guideline. *Z Gastroenterol*. 2011;49:871-930.
- Craig DG, Ford AC, Hayes PC, Simpson KJ. Systematic review: prognostic tests of paracetamol-induced acute liver failure. *Aliment Pharmacol Ther* 2010;31:1064-76.
- Créput C, Blandin F, Deroué B, et al. Long-term effects of calcineurin inhibitor conversion to mycophenolate mofetil on renal function after liver transplantation. *Liver Transpl* 2007;13:1004-10.
- Crippin JS, McCashland T, Terrault N, Sheiner P, Charlton MR. A pilot study of the tolerability and efficacy of antiviral therapy in hepatitis C virus-infected patients awaiting liver transplantation. *Liver Transpl* 2002;8:350-5.
- J S Cross T, Jothimani D, Heneghan MA, Harrison PM. Non-invasive assessment of fibrosis in liver grafts due to hepatitis C virus recurrence. *Clin Transplant* 2011;25:345-51.
- Daly I, Jain A, Reyes J, Fung J. Mycophenolate mofetil for treatment of chronic rejection in liver allograft under tacrolimus. *Transplant Proc* 2002;34:1503.
- Dar FS, Faraj W, Zaman MB, Bartlett A, et al. Outcome of liver transplantation in hereditary hemochromatosis. *Transpl Int* 2009;22:717-24.
- Demetris AJ, Murase N, Lee RG, et al. Chronic rejection. A general overview of histopathology and pathophysiology with emphasis on liver, heart and intestinal allografts. *Ann Transplant* 1997;2:27-44.
- Dew MA, DiMartini AF, Steel J, et al. Meta-analysis of risk for relapse to substance use after transplantation of the liver or other solid organs. *Liver Transpl* 2008;14:159-72.
- Di Benedetto F, Tarantino G, Montalti R, et al. Sorafenib before liver transplantation for hepatocellular carcinoma: risk or give up. *Transpl Int* 2011; 24:e97; doi: 10.1111/j.1432-2277.2011.01329.x.
- DiMartini A, Dew MA, Fitzgerald MG, Fontes P. Clusters of alcohol use disorders diagnostic criteria and predictors of alcohol use after liver transplantation for alcoholic liver disease. *Psychosomatics* 2008;49:332-40.
- Duclos-Vallée JC, Sebah M, Rifai K, et al. A 10 year follow up study of patients transplanted for autoimmune hepatitis: histological recurrence precedes clinical and biochemical recurrence. *Gut*. 2003 Jun;52:893-7.
- Duffy JP, Vardanian A, Benjamin E, et al. Liver transplantation criteria for hepatocellular carcinoma should be expanded: a 22-year experience with 467 patients at UCLA. *Ann Surg* 2007;246:502-9.
- Dutkowski P, Oberkofler CE, Béchir M, et al. The model for end-stage liver disease allocation system for liver transplantation saves lives, but increases morbidity and cost: a prospective outcome analysis. *Liver Transpl* 2011;17:674-84.
- Eid AJ, Razonable RR. New developments in the management of cytomegalovirus infection after solid organ transplantation. *Drugs* 2010; 70:965-81.
- Erim Y, Böttcher M, Dahmen U, Beck O, Broelsch CE, Helander A. Urinary ethyl glucuronide testing detects alcohol consumption in alcoholic liver disease patients awaiting liver transplantation. *Liver Transpl* 2007;13:757-61.
- Everson GT, Trotter J, Forman L, et al. Treatment of advanced hepatitis C with a low accelerating dosage regimen of antiviral therapy. *Hepatology* 2005;42:255-62.
- Feng S, Goodrich NP, Bragg-Gresham JL, et al. Characteristics associated with liver graft failure: the concept of a donor risk index. *Am J Transplant* 2006;6:783-90.

## 378 Hepatology 2012

- Fevry J, Henckaerts L, Van Oirbeek R, et al. Malignancies and mortality in 200 patients with primary sclerosing cholangitis: a long-term single-centre study. *Liver Int* 2012;32:214-22.
- Filippini F, Callea F, Salizzoni M, et al. Double-blind comparison of hepatitis C histological recurrence rate in HCV+ liver transplant recipients given basiliximab + steroids or basiliximab + placebo, in addition to cyclosporine and azathioprine. *Transplantation* 2004;78:1488-95.
- Finkelstein SD, Marsh W, Demetris AJ, et al. Microdissection-based allelo-typing discriminates de novo tumor from intrahepatic spread in hepatocellular carcinoma. *Hepatology* 2003;37:871-9.
- Finkenstedt A, Graziadei IW, Oberaigner W, et al. Extensive surveillance promotes early diagnosis and improved survival of de novo malignancies in liver transplant recipients. *Am J Transplant* 2009; 9:2355-61.
- Forman LM, Lewis DJ, Berlin JA, et al. The association between hepatitis C infection and survival after orthotopic liver transplantation. *Gastroenterology* 2002;122:889-96.
- Frilling A, Malago M, Weber F, et al. Liver transplantation for patients with metastatic endocrine tumors. *Liver Transpl* 2006;12:1089-96.
- Fujiki M, Aucejo F, Kim R. General overview of neo-adjuvant therapy for hepatocellular carcinoma before liver transplantation: necessity or option? *Liver Int* 2011;31:1081-9.
- Fung JJ, Jain A, Kwak EJ, Kusne S, Dvorchik I, Eghtesad B. De novo malignancies after liver transplantation: a major cause of late death. *Liver Transpl* 2001;7:S109-18.
- Fung J, Cheung C, Chan SC, Yuen MF. Entecavir monotherapy is effective in suppressing hepatitis B virus after liver transplantation. *Gastroenterology* 2011;141:1212-9.
- Gane EJ, Lo SK, Riordan SM, et al. A randomized study comparing ribavirin and interferon alfa monotherapy for hepatitis C recurrence after liver transplantation. *Hepatology* 1998;27:1403-7.
- Gane E, Strasser SI, Patterson S, et al. A prospective study on the safety and efficacy of lamivudine and adefovir dipivoxil prophylaxis in HBsAg positive liver transplantation candidates. *Hepatology* 2007;46:479A.
- Garcia CE, Ribeiro HB, Garcia RL, et al. Mycophenolate mofetil in stable liver transplant patients with calcineurin inhibitor-induced renal impairment: single-center experience. *Transplant Proc* 2003;35:1131-2.
- Garg V, van Heeswijk R, Lee JE, Alves K, Nadkarni P, Luo X. Effect of telaprevir on the pharmacokinetics of cyclosporine and tacrolimus. *Hepatology* 2011;54:20-7.
- Gedaly R, Daily MF, Davenport D, et al. Liver transplantation for the treatment of liver metastases from neuroendocrine tumors: an analysis of the UNOS database. *Arch Surg* 2011;146:953-8.
- Germani G, Pleguezuelo M, Villamil F, et al. Azathioprine in liver transplantation: a reevaluation of its use and a comparison with mycophenolate mofetil. *Am J Transplant* 2009;9:1725-31.
- Ghalib R, Pandula R, Kadhim T, et al. Treatment of recurrent hepatitis C after liver transplantation with alpha-2b interferon plus ribavirin. *Hepatology* 2000;32:291A.
- Gonwa TA, Mai ML, Melton LB, Hays SR, et al. End-stage renal disease (ESRD) after orthotopic liver transplantation (OLT) using calcineurin-based immunotherapy: risk of development and treatment. *Transplantation* 2001;72:1934-9.
- Gonzalez-Koch A, Czaja AJ, Carpenter HA, et al. Recurrent autoimmune hepatitis after orthotopic liver transplantation. *Liver Transpl* 2001;7:302-10.
- Gordon FD, Kwo P, Vargas HE. Treatment of hepatitis C in liver transplant recipients. *Liver Transpl* 2009;15:126-35.
- Goss JA, Shackleton CR, Farmer DG, et al. Orthotopic liver transplantation for primary sclerosing cholangitis. A 12-year single center experience. *Ann Surg* 1997;225:472-81.
- Graziadei IW, Wiesner RH, Marotta PJ, et al. Long-term results of patients undergoing liver transplantation for primary sclerosing cholangitis. *Hepatology* 1999;30:1121-7.
- Graziadei IW. Recurrence of primary sclerosing cholangitis after liver transplantation. *Liver Transpl* 2002;8:575-81.
- Graziadei IW, Schwaighofer H, Koch R, et al. Long-term outcome of endoscopic treatment of biliary strictures after liver transplantation. *Liver Transpl* 2006;12:718-25.
- Guba M, von Breitenbuch P, Steinbauer M, et al. Rapamycin inhibits primary and metastatic tumor growth by antiangiogenesis: involvement of vascular endothelial growth factor. *Nat Med* 2002;8:128-35.

- Haber PS, McCaughan GW. "I'll never touch it again, doctor!"-harmful drinking after liver transplantation. *Hepatology* 2007;46:1302-4.
- Hanouneh IA, Macaron C, Lopez R. Risk of colonic neoplasia after liver transplantation for primary sclerosing cholangitis. *Inflamm Bowel Dis* 2012;18:269-74.
- Harper SJ, Gelson W, Harper IG, Alexander GJ, Gibbs P. Switching to sirolimus-based immune suppression after liver transplantation is safe and effective: a single-center experience. *Transplantation* 2011;91:128-32.
- Hashemi N, Araya V, Tufail K, et al. An extended treatment protocol with pegylated interferon and ribavirin for hepatitis C recurrence after liver transplantation. *World J Hepatol* 2011;3:198-204.
- Hashimoto E, Shimada M, Noguchi S, et al. Disease recurrence after living liver transplantation for primary biliary cirrhosis: a clinical and histological follow-up study. *Liver Transpl* 2001;7:588-95.
- Heimbach JK. Successful liver transplantation for hilar cholangiocarcinoma. *Curr Opin Gastroenterol*. 2008;24:384-8.
- Hiatt JR, Carmody IC, Busuttil RW. Should we expand the criteria for hepatocellular carcinoma with living-donor liver transplantation?-no, never. *J Hepatol* 2005;43:573-7.
- Ho GT, Seddon AJ, Therapondos G, Satsangi J, Hayes PC. The clinical course of ulcerative colitis after orthotopic liver transplantation for primary sclerosing cholangitis: further appraisal of immunosuppression post transplantation. *Eur J Gastroenterol Hepatol* 2005;17:1379-85.
- Hong JC, Jones CM, Duffy JP, et al. Comparative analysis of resection and liver transplantation for intrahepatic and hilar cholangiocarcinoma: a 24-year experience in a single center. *Arch Surg* 2011;146:683-9.
- Humar A, Limaye AP, Blumberg EA, et al. Extended valganciclovir prophylaxis in D+/R- kidney transplant recipients is associated with long-term reduction in cytomegalovirus disease: two-year results of the IMPACT study *Transplantation* 2010; 27;90:1427-31.
- Hytioglou P, Gutierrez JA, Freni M, et al. Recurrence of primary biliary cirrhosis and development of autoimmune hepatitis after liver transplant: A blind histologic study. *Hepatol Res* 2009;39:577-84.
- Jacob S, Cicinnati V, Hilgard P, et al. Predictors of graft and patient survival in hepatitis C virus (HCV) recipients: model to predict HCV cirrhosis after liver transplantation. *Transplantation* 2007;84:56-63.
- Iacobellis A, Siciliano M, Perri F, et al. Peginterferon alfa-2b and ribavirin in patients with hepatitis C virus and decompensated cirrhosis: a controlled study. *J Hepatol* 2007;46:185-8.
- Jacob DA, Neumann UP, Bahra M, et al. Long-term follow-up after recurrence of primary biliary cirrhosis after liver transplantation in 100 patients. *Clin Transplant* 2006;20:211-20.
- Jain A, Kashyap R, Demetris AJ, Eghstesad B, Pokharna R, Fung JJ. A prospective randomized trial of mycophenolate mofetil in liver transplant recipients with hepatitis C. *Liver Transpl* 2002;8:47-9.
- Jelic S, Sotiropoulos GC; ESMO Guidelines Working Group. Hepatocellular carcinoma: ESMO Clinical Practice Guidelines for diagnosis, treatment and follow-up. *Ann Oncol* 2010;21:59-64.
- Jiao ZY, Jiao Z. Prophylaxis of recurrent hepatitis B in Chinese patients after liver transplantation using lamivudine combined with hepatitis B immune globulin according to the titer of antibody to hepatitis B surface antigen. *Transplant Proc* 2007;39:1533-6.
- Jimenez C, Marques E, Manrique A, al. Incidence and risk factors of development of lung tumors after liver transplantation. *Transplant Proc* 2005;37:3970-2.
- John PR, Thuluvath PJ. Outcome of patients with new-onset diabetes mellitus after liver transplantation compared with those without diabetes mellitus. *Liver Transpl* 2002;8:708-13.
- Kamdar KY, Rooney CM, Heslop HE. Posttransplant lymphoproliferative disease following liver transplantation. *Curr Opin Organ Transplant* 2011;16:274-80.
- Kapoor D, Guptan RC, Wakil SM, et al. Beneficial effects of lamivudine in hepatitis B virus-related decompensated cirrhosis. *J Hepatol* 2000;33:308-12.
- Karlas T, Hartmann J, Weimann A, et al. Prevention of lamivudine-resistant hepatitis B recurrence after liver transplantation with entecavir plus tenofovir combination therapy and perioperative hepatitis B immunoglobulin only. *Transpl Infect Dis* 2011;13:299-302.

- Kasturi KS, Chennareddygar S, Mummadi RR. Effect of bisphosphonates on bone mineral density in liver transplant patients: a meta-analysis and systematic review of randomized controlled trials. *Transpl Int* 2010;23(2):200-7.
- Kawahara T, Asthana S, Kneteman NM. m-TOR inhibitors: What role in liver transplantation? *J Hepatol* 2011; Jul 23. [Epub ahead of print].
- Kawasaki S, Makuuchi M, Matsunami H, et al. Living related liver transplantation in adults. *Ann Surg* 1998;227:269-74.
- Kemmer N, Kaiser T, Zacharias V, Neff GW. Alpha-1-antitrypsin deficiency: outcomes after liver transplantation. *Transplant Proc* 2008;40:1492-4.
- Khalaf H, Alsuhaibani H, Al-Sugair A et al. Use of yttrium-90 microsphere radioembolization of hepatocellular carcinoma as downstaging and bridge before liver transplantation: a case report. *Transplant Proc* 2010;42:994-8.
- Kizilisik TA, Sebayel M, Hammad A, al-Traif I, Ramirez CG, Abdulla A. Hepatitis C recurrence in liver transplant recipients. *Transplant Proc* 1997;29:2875-7.
- Klintmalm GB, Washburn WK, Rudich SM, et al. Corticosteroid-free immunosuppression with daclizumab in HCV(+) liver transplant recipients: 1-year interim results of the HCV-3 study. *Liver Transpl* 2007;13:1521-31.
- Kneteman NM, Oberholzer J, Al Saghier M, et al. Sirolimus-based immunosuppression for liver transplantation in the presence of extended criteria for hepatocellular carcinoma. *Liver Transpl* 2004;10:1301-11.
- Knight SR, Friend PJ, Morris PJ. Role of transplantation in the management of hepatic malignancy. *Br J Surg* 2007;94:1319-30.
- Konrad T, Steinmüller T, Vicini P, et al. Regulation of glucose tolerance in patients after liver transplantation: impact of cyclosporin versus tacrolimus therapy. *Transplantation* 2000;69: 2072-8.
- Lai JC, Verna EC, Brown RS Jr, et al. Hepatitis C virus-infected women have a higher risk of advanced fibrosis and graft loss after liver transplantation than men. *Hepatology* 2011;54:418-24.
- Lake JR. The role of immunosuppression in recurrence of hepatitis C. *Liver Transpl* 2003;9:S63-6.
- Lehnert T. Liver transplantation for metastatic neuroendocrine carcinoma: an analysis of 103 patients. *Transplantation* 1998;66:1307-12.
- Leithead JA, Ferguson JW, Bates CM, Davidson JS, Simpson KJ, Hayes PC. Chronic kidney disease after liver transplantation for acute liver failure is not associated with perioperative renal dysfunction. *Am J Transplant* 2011;11:1905-15.
- Lerut J, Bonaccorsi-Riani E, Finet P, Gianello P. Minimization of steroids in liver transplantation. *Transpl Int* 2009; 22:2-19.
- Levitsky J, Thudi K, Ison MG, Wang E, Abecassis M. Alemtuzumab induction in non-hepatitis C positive liver transplant recipients. *Liver Transpl* 2011;17:32-7.
- Liang W, Wang D, Ling X, et al. Sirolimus-based immunosuppression in liver transplantation for hepatocellular carcinoma: A meta-analysis. *Liver Transpl* 2011. doi: 10.1002/lt.22441. [Epub ahead of print]
- Liermann Garcia RF, Evangelista Garcia C, McMaster P, Neuberger J. Transplantation for primary biliary cirrhosis: retrospective analysis of 400 patients in a single center. *Hepatology* 2001;33:22-7.
- Liu X, Ling Z, Li L, Ruan B. Invasive fungal infections in liver transplantation. *Int J Infect Dis* 2011;15:e298-304.
- Llado L, Fabregat J, Castellote J, et al. Impact of immunosuppression without steroids on rejection and hepatitis C virus evolution after liver transplantation: results of a prospective randomized study. *Liver Transpl* 2008;14:1752-60.
- Lo CM, Fan ST, Liu CL, et al. Lessons learned from one hundred right lobe living donor liver transplants. *Ann Surg* 2004;240:151-8.
- Lo CM, Liu CL, Lau GK, Chan SC, Ng IO, Fan ST. Liver transplantation for chronic hepatitis B with lamivudine-resistant YMDD mutant using add-on adefovir dipivoxil plus lamivudine. *Liver Transpl* 2005;11:807-13.
- Lo CM. Liver transplantation for acute liver failure: not too early but never too late. *Liver Transpl* 2008 Sep;14:1243-4.
- Marsh JW, Finkelstein SD, Demetris AJ, et al. Genotyping of hepatocellular carcinoma in liver transplant recipients adds predictive power for determining recurrence-free survival. *Liver Transpl* 2003;9:664-71.

- Martin AP, Bartels M, Redlich J, Hauss J, Fangmann J. A single center experience with liver transplantation for Wilson's disease. *Clin Transplant* 2008;22:216-21.
- Martin P, Busuttil RW, Goldstein RM, et al. Impact of tacrolimus versus cyclosporine in hepatitis C virus-infected liver transplant recipients on recurrent hepatitis: a prospective, randomized trial. *Liver Transpl* 2004;10:1258-62.
- Marzano A, Salizzoni M, Debernardi-Venon W, et al. Prevention of hepatitis B virus recurrence after liver transplantation in cirrhotic patients treated with lamivudine and passive immunoprophylaxis. *J Hepatol* 2001;34:903-10.
- Marzano A, Lampertico P, Mazzaferro V, et al. Prophylaxis of hepatitis B virus recurrence after liver transplantation in carriers of lamivudine-resistant mutants. *Liver Transpl* 2005;11:532-8.
- Masetti M, Montalti R, Rompianesi G, et al. Early withdrawal of calcineurin inhibitors and everolimus monotherapy in de novo liver transplant recipients preserves renal function. *Am J Transplant* 2010;10:2252-62.
- Massie AB, Caffo B, Gentry SE, Hall EC. MELD Exceptions and Rates of Waiting List Outcomes. *Am J Transplant* 2011;11:2362-71.
- Masuoka HC, Rosen CB. Transplantation for cholangiocarcinoma. *Clin Liver Dis* 2011;15:699-715.
- McCaughan GW, Zekry A. Impact of immunosuppression on immunopathogenesis of liver damage in hepatitis C virus-infected recipients following liver transplantation. *Liver Transpl* 2003;9:S21-7.
- McKenna GJ, Trotter JF, Klintmalm E. Limiting hepatitis C virus progression in liver transplant recipients using sirolimus-based immunosuppression. *Am J Transplant* 2011;11:2379-87.
- Melero J, Berenguer M. Antiviral therapy in patients with HCV-cirrhosis. *Ann Hepatol* 2009;8:292-7.
- Mendes F, Couto CA, Levy C. Recurrent and de novo autoimmune liver diseases. *Clin Liver Dis*. 2011;15:859-78.
- Merion RM, Schaubel DE, Dykstra DM, et al. The survival benefit of liver transplantation. *Am J Transplant* 2005;5:307-13.
- Merli M, Giannelli V, Gentili F, et al. Ribavirin priming improves the virological response to antiviral treatment in transplanted patients with recurrent hepatitis C: a pilot study. *Antivir Ther* 2011;16:879-85.
- Moini M, Mistry P, Schilsky ML. Liver transplantation for inherited metabolic disorders of the liver. *Curr Opin Organ Transplant* 2010;15:269-76.
- Molmenti EP, Netto GJ, Murray NG, et al. Incidence and recurrence of autoimmune/alloimmune hepatitis in liver transplant recipients. *Liver Transpl* 2002;8:519-26.
- Montano-Loza AJ, Wasilenko S, Bintner J, Mason AL. Cyclosporine A protects against primary biliary cirrhosis recurrence after liver transplantation. *Am J Transplant* 2010;10:852-8.
- Moon DB, Lee SG. Liver transplantation. *Liver Transpl* 2011;doi:10.1002/lt.22455 [Epub ahead of print].
- Moreira Kulak CA, Cochenski B, Borba VZ, Kulak J, et al. Post-transplantation osteoporosis. *Arq Bras Endocrinol Metab* 2010;54:143-9.
- Moreno JM, Rubio E, Pons F, et al. Usefulness of mycophenolate mofetil in patients with chronic renal insufficiency after liver transplantation. *Transplant Proc* 2003;35:715-7.
- Moreno Planas JM, Cuervas-Mons Martinez V, Rubio Gonzalez E, et al. Mycophenolate mofetil can be used as monotherapy late after liver transplantation. *Am J Transplant* 2004;4:1650-5.
- Morioka D (a), Egawa H, Kasahara M, et al. Impact of human leukocyte antigen mismatching on outcomes of living donor liver transplantation for primary biliary cirrhosis. *Liver Transpl* 2007;13:80-90.
- Morioka D (b), Egawa H, Kasahara M, et al. Outcomes of adult-to-adult living donor liver transplantation. A single institution's experience with 335 consecutive cases. *Ann Surg* 2007;245:315-25.
- Naoumov NV, Lopes AR, Burra P, et al. Randomized trial of lamivudine versus hepatitis B immunoglobulin for long-term prophylaxis of hepatitis B recurrence after liver transplantation. *J Hepatol* 2001;34:888-94.
- Nath DS, Kalis A, Nelson S, Payne WD, Lake JR, Humar A. Hepatitis B prophylaxis post-liver transplant without maintenance hepatitis B immunoglobulin therapy. *Clin Transplant* 2006;20:206-10.

- Neff GW, Kemmer N, Kaiser TE, et al. Combination therapy in liver transplant recipients with hepatitis B virus without hepatitis B immune globulin. *Dig Dis Sci* 2007;52:2497-500.
- Neuberger J. Incidence, timing, and risk factors for acute and chronic rejection. *Liver Transpl Surg* 1999;5:S30-6.
- Nikolaidis N, Vassiliadis T, Gioulema O, et al. Effect of lamivudine treatment in patients with decompensated cirrhosis due to anti-HBe positive/HBeAg-negative chronic hepatitis B. *Clin Transplant* 2005;19:321-6.
- Pabón V, Dumortier J, Gincul R, et al. Long-term results of liver transplantation for Wilson's disease. *Gastroenterol Clin Biol* 2008;32:378-81.
- Pascher A, Sauer IM, Walter M, et al. Donor evaluation, donor risks, donor outcome, and donor quality of life in adult-to-adult living donor liver transplantation. *Liver Transpl* 2002;8:829-37.
- Pascher A, Neuhaus P. Bile duct complications after liver transplantation. *Transpl Int* 2005;18:627-42.
- Patel S, Orloff M, Tsoulfas G, et al. Living donor liver transplantation in the United States: identifying donors at risk for perioperative complications. *Am J Transplant* 2007;7:2344-9.
- Paya C, Humar A, Dominguez E, et al. Efficacy and safety of valganciclovir vs. oral ganciclovir for prevention of cytomegalovirus disease in solid organ transplant recipients. *Am J Transplant* 2004;4:611-20.
- Perkins JD. Biliary tract complications: The most common postoperative complication in living liver donors. *Liver Transpl* 2008;14:1372-7.
- Perney P, Bismuth M, Sigaud H, et al. Are preoperative patterns of alcohol consumption predictive of relapse after liver transplantation for alcoholic liver disease? *Transpl Int* 2005;18:1292-7.
- Pfitzmann R, Schwenzer J, Rayes N, Seehofer D, Neuhaus R, Nüssler NC. Long-term survival and predictors of relapse after orthotopic liver transplantation for alcoholic liver disease. *Liver Transpl* 2007;13:197-205.
- Picciotto FP, Tritto G, Lanza AG, et al. Sustained virological response to antiviral therapy reduces mortality in HCV reinfection after liver transplantation. *J Hepatol* 2007;46:459-65.
- Pomfret EA, Washburn K, Wald C et al. Report of a national conference on liver allocation in patients with hepatocellular carcinoma in the United States. *Liver Transpl* 2010;16:262-78.
- Prados E, Cuervas-Mons V, de la Mata M, et al. Outcome of autoimmune hepatitis after liver transplantation. *Transplantation* 1998;66:1645-50.
- Qin YS, Li ZS, Sun ZX, Wu RP, Wang N, Yao YZ. Endoscopic management of biliary complications after orthotopic liver transplantation. *Hepatobiliary Pancreat Dis Int* 2006;5:39-42.
- Qiu J, Ozawa M, Terasaki PI. Liver transplantation in the United States. *Clin Transpl* 2005;17:28.
- Radunz S, Juntermanns B, Kaiser GM et al. Efficacy and safety of linezolid in liver transplant patients. *Transpl Infect Dis* 2011;13:353-8.
- Raimondo ML, Dagher L, Papatheodoridis GV, et al. Long-term mycophenolate mofetil monotherapy in combination with calcineurin inhibitors for chronic renal dysfunction after liver transplantation. *Transplantation* 2003;75:186-90.
- Razonable RR, Zerr DM and the AST Infectious Diseases Community of Practice. HHV-6, HHV-7 and HHV-8 in Solid Organ Transplant Recipients. *Am J Transplant* 2009; 9 S97-S103.
- Rea DJ, Heimbach JK, Rosen CB. Liver transplantation with neoadjuvant chemoradiation is more effective than resection for hilar cholangiocarcinoma. *Ann Surg* 2005;242:451-8.
- ReViS-TC Study Group. Cyclosporine a-based immunosuppression reduces relapse rate after antiviral therapy in transplanted patients with hepatitis C virus infection: a large multicenter cohort study. *Transplantation* 2011;92:334-40.
- Ringe B, Wittekind C, Bechstein WO, et al. The role of liver transplantation in hepatobiliary malignancy. A retrospective analysis of 95 patients with particular regard to tumor stage and recurrence. *Ann Surg* 1989;209:88-98.
- Roayie K, Feng S. Allocation policy for hepatocellular carcinoma in the MELD era: room for improvement? *Liver Transpl* 2007;13:S36-43.

- Rosen HR, Shackleton CR, Higa L, et al. Use of OKT3 is associated with early and severe recurrence of hepatitis C after liver transplantation. *Am J Gastroenterol* 1997;92:1453-7.
- Rubín A, Aguilera V, Berenguer M. Liver transplantation and hepatitis C. *Clin Res Hepatol Gastroenterol* 2011 [Epub ahead of print].
- Rudraraju M, Osowo AT, Singh V, Carey EJ. Do patients need more frequent colonoscopic surveillance after liver transplantation? *Transplant Proc* 2008;40:1522-4.
- Saab S, Niho H, Comulada S, et al. Mortality predictors in liver transplant recipients with recurrent hepatitis C cirrhosis. *Liver Int* 2005;25:940-5.
- Saab S, Desai S, Tsaot D, et al. Posttransplantation hepatitis B prophylaxis with combination oral nucleoside and nucleotide analog therapy. *Am J Transplant* 2011;11:511-7.
- Saliba F, Dharancy S, Lorho R, et al. Conversion to everolimus in maintenance liver transplant patients: a multicenter, retrospective analysis. *Liver Transpl* 2011;17:905-13.
- Samonakis DN, Cholongitas E, Triantos CK, et al. Sustained, spontaneous disappearance of serum-HCV under immunosuppression after liver transplantation for hepatitis C cirrhosis. *J Hepatol* 2005;43:1091-3.
- Sanchez EQ, Martin AP, Ikegami T, et al. Sirolimus conversion after liver transplantation: improvement in measured glomerular filtration rate after 2 years. *Transplant Proc* 2005;37:4416-23.
- Saner FH, Cicinnati VR, Sotiropoulos G, Beckebaum S. Strategies to prevent or reduce acute and chronic kidney injury in liver transplantation. *Liver Int* 2011; [Epub ahead of print].
- Schacherer D, Zeitoun M, Buttner R, et al. Sirolimus-induced drug fever and ciclosporin-induced leukoencephalopathy with seizures in one liver transplant recipient. *World J Gastroenterol* 2007;13:6090-3.
- Schiff E, Lai CL, Hadziyannis S, et al. Adefovir dipivoxil for wait-listed and post-liver transplantation patients with lamivudine-resistant hepatitis B: final long-term results. *Liver Transpl* 2007;13:349-60.
- Schlitt HJ, Loss M, Scherer M, et al. Current developments in liver transplantation in Germany: MELD-based organ allocation and incentives for transplant centres. *Z Gastroenterol* 2011;49: 30-8. PMID 21225535.
- Schmeding M, Kiessling A, Neuhaus R et al. Mycophenolate mofetil monotherapy in liver transplantation: 5-year follow-up of a prospective randomized trial. *Transplantation* 2011;92:923-9.
- Schnitzbauer AA (a), Scherer MN, Rochon J, et al. Study protocol: a pilot study to determine the safety and efficacy of induction-therapy, de novo MPA and delayed mTOR-inhibition in liver transplant recipients with impaired renal function. PATRON-study. *BMC Nephrol* 2010;11:24.
- Schnitzbauer AA (b), Zuelke C, Graeb C, et al. A prospective randomised, open-labeled, trial comparing sirolimus-containing versus mTOR-inhibitor-free immunosuppression in patients undergoing liver transplantation for hepatocellular carcinoma. *BMC Cancer* 2010;10:190.
- Shergill AK, Khalili M, Straley S, et al. Applicability, tolerability, and efficacy of preemptive antiviral therapy in hepatitis C infected patients undergoing liver transplantation. *Am J Transplant* 2005;5:118-24.
- Silva MF, Sherman M. Criteria for liver transplantation for HCC: What should the limits be? *J Hepatol* 2011;55:1137-47.
- Silveira MG, Talwalkar JA, Lindor KD, Wiesner RH. Recurrent primary biliary cirrhosis after liver transplantation. *Am J Transplant* 2010;10:720-6.
- Smets F, Sokal EM. Epstein-Barr virus-related lymphoproliferation in children after liver transplant: role of immunity, diagnosis, and management. *Pediatr Transplant* 2002;6:280-7.
- Soliman T, Hetz H, Burghuber C. Short-term induction therapy with anti-thymocyte globulin and delayed use of calcineurin inhibitors in orthotopic liver transplantation. *Liver Transpl* 2007;13:1039-44.
- Sotiropoulos GC, Molmanti EP, Löscher C, Beckebaum S, Brolesch CE, Lang H. Meta-analysis of tumor recurrence after liver transplantation for hepatocellular carcinoma based on 1,198 cases. *Eur J Med Res* 2007;12:527-34.
- Sotiropoulos CG (a), Beckebaum S, Lang H, et al. Single-center experience on liver transplantation for hepatocellular carcinoma arising in alcoholic cirrhosis: results and ethical issues. *Eur Surg Res* 2008;40:7-13.

- Sotiropoulos GC (b), Lang H, Sgourakis G, et al. Liberal policy in living donor liver transplantation for hepatocellular carcinoma: Lessons learned. *Dig Dis Sci* 2008. [Epub ahead of print].
- Starzl TE, Marchioro TL, Von Kaulla KN, et al. Homotransplantation of the liver in humans. *Surg Gynecol Obstet* 1963;117:659-76.
- Starzl TE, Groth CG, Brettschneider L, et al. Orthotopic homotransplantation of the human liver. *Ann Surg* 1968;168:392-415.
- Staufer K, Andresen H, Vettorazzi E, et al. Urinary ethyl glucuronide as a novel screening tool in patients pre and post liver transplantation improves detection of alcohol consumption. *Hepatology* 2011; doi: 10.1002/hep.24596. [Epub ahead of print]
- Sugawara Y, Makuuchi M. Technical advances in living-related liver transplantation. *J Hepatobiliary Pancreat Surg* 1999;6:245-53.
- Sugawara Y, Makuuchi M, Matsui Y, et al. Preemptive therapy for hepatitis C virus after living-donor liver transplantation. *Transplantation* 2004;78:1308-11.
- Sugawara Y, Makuuchi M. Living donor liver transplantation: present status and recent advances. *Br Med Bull* 2005;75-76:15-28.
- Sutcliffe RP, Maguire DD, Muiresan P, et al. Liver transplantation for Wilson's disease: long-term results and quality-of-life assessment. *Transplantation* 2003;75:1003-6.
- Sylvestre PB, Batts KP, Burgart LJ, Poterucha JJ, Wiesner RH. Recurrence of primary biliary cirrhosis after liver transplantation: Histologic estimate of incidence and natural history. *Liver Transpl* 2003;9:1086-93.
- Testa G, Crippin JS, Netto GJ, et al. Liver transplantation for hepatitis C: recurrence and disease progression in 300 patients. *Liver Transpl* 2000;6:553-61.
- Thomas RM, Brems JJ, Guzman-Hartman G, Yong S, Cavaliere P, van Thiel DH. Infection with chronic hepatitis C virus and liver transplantation: a role for interferon therapy before transplantation. *Liver Transpl* 2003;9:905-15.
- Togashi J, Sugawara Y, Tamura S, et al. Basiliximab as therapy for acute rejection after liver transplantation for hepatitis C virus cirrhosis. *Biosci Trends* 2011;5:57-60.
- Toniutto P, Fabris C, Fumo E, et al. Pegylated versus standard interferon-alpha in antiviral regimens for post-transplant recurrent hepatitis C: comparison of tolerability and efficacy. *J Gastroenterol Hepatol* 2005;20:577-82.
- Toso C, Meeberg GA, Bigam DL, et al. De novo sirolimus-based immunosuppression after liver transplantation for hepatocellular carcinoma: long-term outcomes and side effects. *Transplantation* 2007;83:1162-8.
- Toso C, Mentha G, Kneteman NM, Majno P. The place of downstaging for hepatocellular carcinoma. *J Hepatol* 2010;52:930-6.
- Tournoux-Facon C, Paoletti X, Barbare JC, et al. Development and validation of a new prognostic score of death for patients with hepatocellular carcinoma in palliative setting. *J Hepatol* 2011;54:108-14.
- Triantos C, Samonakis D, Stigliano R, Thalheimer U, Patch D, Burroughs A. Liver transplantation and hepatitis C virus: systematic review of antiviral therapy. *Transplantation* 2005;79:261-8.
- Tripathi D, Neuberger J. Autoimmune hepatitis and liver transplantation: indications, results, and management of recurrent disease. *Semin Liver Dis* 2009;29:286-96.
- Tung BY, Kimmey MB. Biliary complications of orthotopic liver transplantation. *Dig Dis* 1999;17:133-44.
- Ulrich C, Degen A, Patel MJ, Stockfleth. Sunscreens in organ transplant patients. *Nephrol Dial Transplant* 2008;23:1805-8.
- Vagefi PA, Ascher NL, Freise CE, Dodge JL, Roberts JP. The use of living donor liver transplantation varies with the availability of deceased donor liver transplantation. *Liver Transpl* 2011; doi: 10.1002/lt.22455.
- Valentin-Gamazo C, Malago M, Karliova M, et al. Experience after the evaluation of 700 potential donors for living donor liver transplantation in a single center. *Liver Transpl* 2004; 10: 1087-96.
- Vallejo GH, Romero CJ, de Vicente JC. Incidence and risk factors for cancer after liver transplantation. *Crit Rev Oncol Hematol* 2005;56:87-99.
- Vera A, Moledina S, Gunson B, et al. Risk factors for recurrence of primary sclerosing cholangitis of liver allograft. *Lancet* 2002;360:1943-4.
- Verdonk RC, Buis CI, van der Jagt EJ, et al. Nonanastomotic biliary strictures after liver transplantation, part 2: Management, outcome, and risk factors for disease progression. *Liver Transpl* 2007;13:725-32.



- Vogel A, Heinrich E, Bahr MJ, et al. Long-term outcome of liver transplantation for autoimmune hepatitis. *Clin Transplant* 2004;18:62-9.
- Washington K. Update on post-liver transplantation infections, malignancies, and surgical complications. *Adv Anat Pathol* 2005;12:221-6.
- Watson CJ, Friend PJ, Jamieson NV, et al. Sirolimus: a potent new immunosuppressant for liver transplantation. *Transplantation* 1999;67:505-9.
- Weber NK, Forman LM, Trotter JF. HbIg discontinuation with maintenance oral anti-viral therapy and HBV vaccination in liver transplant recipients. *Dig Dis Sci* 2010; 55: 505-9.
- Weiss KH, Gotthardt D, Schmidt J, et al. Liver transplantation for metabolic liver diseases in adults: indications and outcome. *Nephrol Dial Transplant* 2007;22(Suppl 8):viii9-12.
- Weismüller TJ, Prokein J, Becker T, et al. Prediction of survival after liver transplantation by pre-transplant parameters. *Scand J Gastroenterol* 2008;43:736-46.
- Welch CS. A note on transplantation of the whole liver in dogs. *Transplant Bull* 1955;2:54-5.
- Wibaux C, Legroux-Gerot I, Dharancy S, et al. Assessing bone status in patients awaiting liver transplantation. *Joint Bone Spine* 2011; 78:387-91.
- Wiesner RH, Shorr JS, Steffen BJ, Chu AH, Gordon RD, Lake JR. Mycophenolate mofetil combination therapy improves long-term outcomes after liver transplantation in patients with and without hepatitis C. *Liver Transpl* 2005;11:750-9.
- Wigg AJ, Gunson BK, Mutimer DJ. Outcomes following liver transplantation for seronegative acute liver failure: experience during a 12-year period with more than 100 patients. *Liver Transpl* 2005;11:27-34.
- Wong PY, Portmann B, O'Grady JG, et al. Recurrence of primary biliary cirrhosis after liver transplantation following FK506-based immunosuppression. *J Hepatol* 1993;17:284-7.
- Wong SN, Chu CJ, Wai CT, et al. Low risk of hepatitis B virus recurrence after withdrawal of long-term hepatitis B immunoglobulin patients receiving maintenance nucleos(t)ide analogue therapy. *Liver Transpl* 2007;13:374-81.
- Yahyazadeh A, Beckebaum S, Cicinnati V, et al. Efficacy and safety of subcutaneous human HBV-immunoglobulin (Zutectra) in liver transplantation: an open, prospective, single-arm phase III study. *Transpl Int* 2011;24:441-50.
- Yan ML, Yan LN, Li B, et al. Intramuscular hepatitis B immune globulin combined with lamivudine in prevention of hepatitis B recurrence after liver transplantation. *Hepatobiliary Pancreat Dis Int* 2006;5:360-3.
- Yao FY, Xiao L, Bass NM, Kerlan R, Ascher NL, Roberts JP. Liver transplantation for hepatocellular carcinoma: validation of the UCSF-expanded criteria based on preoperative imaging. *Am J Transpl* 2007;7:2587-96.
- Yoshida H, Kato T, Levi DM, et al. Lamivudine monophylaxis for liver transplant recipients with non-replicating hepatitis B virus infection. *Clin Transplant* 2007;21:166-71.
- Yoshida EM, Marotta PJ, Greig PD, et al. Evaluation of renal function in liver transplant recipients receiving daclizumab (Zenapax), mycophenolate mofetil, and a delayed, low-dose tacrolimus regimen vs. a standard-dose tacrolimus and mycophenolate mofetil regimen: a multicenter randomized clinical trial. *Liver Transpl* 2005;11:1064-72.
- Yu L, Ioannou GN. Survival of liver transplant recipients with hemochromatosis in the United States. *Gastroenterology* 2007;133:489-95.
- Zavaglia C, De Carlis L, Alberti AB, et al. Predictors of long term survival after liver transplantation for hepatocellular carcinoma. *Am J Gastroenterol* 2005;100:2708-16.
- Zheng S, Chen Y, Liang T, et al. Prevention of hepatitis B recurrence after liver transplantation using lamivudine or lamivudine combined with hepatitis B immunoglobulin prophylaxis. *Liver Transpl* 2006;12:253-8.
- Zimmerman MA, Trotter JF, Wachs M, et al. Sirolimus-based immunosuppression following liver transplantation for hepatocellular carcinoma. *Liver Transpl* 2008;14:633-8.
- Ziolkowski J, Paczek L, Senatorski G, et al. Renal function after liver transplantation: calcineurin inhibitor nephrotoxicity. *Transplant Proc* 2003;35:2307-9.
- Zoepf T, Maldonado-Lopez EJ, Hilgard P, et al. Balloon dilatation vs. balloon dilatation plus bile duct endoprosthesis for treatment of anastomotic biliary strictures after liver transplantation. *Liver Transpl* 2006;12:88-94.

## 23. End-stage Liver Disease, HIV Infection and Liver Transplantation

*José M. Miró, Fernando Agüero, Montserrat Laguno, Christian Manzardo, Montserrat Tuset, Carlos Cervera, Neus Freixa, Asuncion Moreno, Juan-Carlos García-Valdecasas, Antonio Rimola, and the Hospital Clinic OLT in HIV Working Group*

### Introduction

Liver disease due to chronic hepatitis B and C is currently one of the leading causes of morbidity and mortality among HIV-positive patients in the developed world and its burden is increasing (Joshi 2011). Non-coinfected patients with chronic hepatitis C tend to progress to end-stage liver disease (ESLD) in 20-30 years, whereas coinfecting patients have higher rates of progression (Mohsen 2003; Poynard 2003). Furthermore, a higher overall adjusted relative risk (RR) of histological cirrhosis or decompensated liver disease has been observed in patients coinfecting with HIV and the hepatitis C virus (HCV) when compared to HCV-monoinfected patients (Graham 2001). End-stage liver disease (ESLD) in coinfecting patients has become a leading clinical state in many of these patients. Medical management is essential in this scenario and should be considered as a bridge to organ liver transplantation (OLT), which can play an important role as a therapeutic tool in this subset of patients. We summarize recent developments in the management of ESLD. Nevertheless this is an evolving field and many issues remain unclear (Miró 2011).

### Epidemiology

Of the approximately 40 million persons infected with HIV globally, 2 to 4 million are chronically infected with the hepatitis B virus (HBV) and 4 to 5 million have chronic HCV (Alter 2006).

The prevalence of HCV and/or HBV coinfection is high in developed countries. Studies performed in European HIV-positive patients showed rates of 33% and 9%, respectively (Rockstroh 2005, Konopnicki 2005), while in the US figures are very similar, 28% and 9% (Fung 2004). Other authors have addressed the significance of HCV as a cause of non-AIDS-related death (Palella 2006, Crum 2006, Lewden 2005). One single-centre study (Martínez 2007) in Spain analysed the cause of 235

deaths in 4471 patients (5%) on combination antiretroviral therapy (cART) from 1997 until 2004. The number of patients who died from ESLD increased from 8% in 1997 to 41% in 2004, and in recent years this condition has become the leading cause of death in HIV-positive patients. In comparison with the general population of a similar age, deaths due to liver disease were 11 times more frequent in HIV-positive patients. Another prospective multicenter study (Rosenthal 2007) in France determined mortality due to ESLD in a nationwide population of HIV-positive patients. The authors followed a total of 21,000 HIV-positive patients, 4000 (19.9%) of whom were coinfecting, and showed that, in 2003, mortality due to ESLD represented 23.7% of non-AIDS-related deaths. In this population, ESLD was fatal in 1.5% of patients in 1995, 6.6% in 1997, 14.3% in 2001, and 12.6% in 2003, and 92.6% of patients who died from ESLD had chronic HCV infection. Another prospective study of 11 cohorts carried out in Europe, the United States and Australia (D:A:D Study 2006) included 23,500 HIV-1-infected patients (22.5% were HCV-positive) and followed them from December 1999 until February 2004. This study showed that, of the 1250 deaths recorded, those related to AIDS were the most frequent (31.1%), while liver disease was the most frequent non-AIDS-related cause (14.5%). HCV infection was shown to be an independent predictor of liver-related death (D:A:D Study 2006). As for hepatocellular carcinoma (HCC), one study comparing liver-related deaths in HIV-positive patients (Salmon-Ceron 2009) described an increase in mortality due to HCC from 15% in 2000 to 25% in 2005 ( $p=0.04$ ).

## Clinical features of coinfecting patients with ESLD

154 patients with a new diagnosis of Child-Turcotte-Pugh class A compensated cirrhosis were followed and 36 of them (23.4%) developed a first hepatic decompensation during follow-up (mean 36 months) (Pineda 2009). The probability of developing decompensated cirrhosis at 3 and 5 years was 26% and 33%, respectively. Factors predicting the emergence of an episode of hepatic decompensation at 5 years were Child-Turcotte-Pugh stage (HR, 3.33 [95% CI, 1.39-7.69]), lack of anti-HCV therapy (HR, 3.38 [95% CI, 1.14-5.04]), and baseline CD4 cell count below 300 cells/mm<sup>3</sup> (HR, 2.40 [95% CI, 1.09-10.53]).

In a retrospective study, the same authors (Pineda 2005) described the frequency of specific events, such as first decompensation and cause of death in HIV-negative and HIV/HCV-coinfecting subjects. Ascites and jaundice were more frequent among HIV-positive patients, while upper gastrointestinal bleeding and HCC were more frequent in mono-infected patients. Hepatic encephalopathy (HE) as both first decompensation and cause of death was higher in coinfecting patients.

The clinical characteristics and outcome of spontaneous bacterial peritonitis (SBP) were evaluated in an HIV-positive population with cirrhosis (Shaw 2006). Thirty-five HIV-positive patients with cirrhosis were compared with 70 HIV-negative patients with cirrhosis. An aetiologic diagnosis was made in almost 80% of the HIV-positive cases and bacteraemia was present in more than 50%, with both rates being higher than those observed in HIV-negative patients. An important bacteriological finding in this study was the high incidence of *Streptococcus pneumoniae* as the etiologic agent of SBP among HIV-positive patients, second only to *Escherichia coli*.

HCC has a faster and worse outcome in HIV/HCV-coinfected patients than in HCV-monoinfected patients (Puoti 2004, Bruno 2006, Berretta 2011). Of note, this disorder is expected to rise significantly in patients with HIV infection and chronic VHC/VHB hepatitis.

The findings of HCC in 41 HIV-positive and 2384 HIV-negative patients were compared in an Italian study (Puoti 2004). The authors found a more aggressive course of HCC in HIV-positive patients, with an independent association between HIV infection and a more advanced stage of HCC at clinical presentation, in addition to a higher rate of infiltrating neoplasm and extrahepatic-extranodal metastasis. Furthermore, portal vein thrombosis was more frequent among HIV-positive patients with HCC.

A retrospective study from Canada and the US compared 63 HIV-positive patients with HCC and 226 HIV-negative patients with HCC (Bräu 2007) and revealed that HIV+ patients were younger and more frequently symptomatic. In this cohort, median survival was similar between HIV-positive (7 months) and HIV-negative patients (7.5 months,  $p=0.44$ , log-rank), as was tumour stage.

Recently, these findings were confirmed grouping a comparison of 104 HIV-infected patients who had HCC with 484 HIV-uninfected patients with HCC (Berretta 2011). The group of patients with HIV infection was younger, had better BCLC stage at diagnosis and the median survival time was significantly shorter. One of the factors independently associated with survival was the HCC diagnosis via a screening program. However, there are no data available on the cost-effectiveness of screening for HCC in cirrhotic patients with HIV infection (Joshi 2011).

## Prognosis after decompensation

The survival rate of HIV-positive patients with decompensated cirrhosis is much lower than that of HIV-negative patients – approximately 50% at 1 year (Pineda 2005, Merchante 2006, Murillas 2009). In a multicentre case-control study (Pineda 2005), the outcome of cirrhosis after the first decompensation in coinfecting patients was much worse than in the monoinfected population. Survival at 1, 2, and 5 years for the coinfecting/monoinfected population was 54%/74%, 40%/61%, and 25%/44%, respectively. In another study (Merchante 2006) severity of liver disease (Child-Turcotte-Pugh score or HE as the first hepatic decompensation) and the level of cellular immunosuppression ( $<100$  CD4 cells) were identified as independent predictors of poor outcome in coinfecting patients. On the other hand, HAART was associated with a reduced mortality rate.

104 HIV-positive patients with HCC or cirrhosis after their first hepatic decompensation were analysed (Murillas 2009). The median survival time of this cohort was 14 months, similar to that observed by Merchante (13 months). This study included HCV and non-HCV-infected patients, and it did not find significant differences in survival based on the aetiology of cirrhosis, suggesting that HIV-positive patients have an overall poor outcome regardless of the nature of their liver disease. Furthermore, the MELD score and the inability to reach an undetectable plasma HIV-1 viral load at any time during follow-up were the only variables independently associated with the risk of death ( $p<0.001$ ). This is particularly relevant because the MELD score has been increasingly used to establish the

prognosis of patients with cirrhosis and, consequently, to indicate liver transplantation.

Recently, a Spanish study (Lopez-Diéguez 2011) showed that the mortality rate for patients with decompensated cirrhosis was 27.1 deaths/100 person years and 4.0 deaths/100 person years for patients with compensated cirrhosis. The risk of first hepatic decompensation was relatively low but the time from the first liver decompensation to the next decompensation was critically reduced. HIV-positive patients with cirrhosis have a poor prognosis after the development of SBP (Shaw 2006). HIV infection was associated with a more than 6-fold increase in the probability of dying within a month of the first episode of SBP. Impaired renal function at diagnosis and severity of liver disease were identified as predictors of death. HIV-positive patients also had a dramatically shorter survival time than HIV-negative patients: only 50% of patients were still alive 3 months after the first episode of SBP and only 23% were alive after 1 year. Death was mostly related to complications of advanced liver disease rather than to AIDS-related conditions.

High mortality rates among coinfectd patients with ESLD waiting for liver transplantation have also been reported in observational studies (Maida 2005, Prieto 2008, Murillas 2009). One study (Prieto 2008) analysed 18 patients who were on the waiting list for OLT. Eight (44%) received a transplant, 8 (44%) died while on the waiting list, and 2 (12%) were still on the waiting list at the end of the study (Prieto 2008). 10 (67%) out of 15 patients on the transplant waiting list died after a median follow-up of 5 months, and 5 (33%) underwent liver transplantation (Murillas 2009).

Two case-control studies have analysed mortality rates among coinfectd patients with ESLD waiting for liver transplantation. In the first (Ragni 2005), mortality rates during the pre-transplant evaluation in HIV-positive (N=58) and HIV-negative (N=1359) patients were 36% and 15%, respectively ( $p<0.001$ ), although these data were not confirmed by the second (Subramanian 2009). Waiting list mortality was 14.4% in patients with HIV infection (N=167) and 11.1% in the control group (N=792) ( $p=0.30$ ). In a multivariate analysis, a MELD score higher than 25 was the only variable related to death on the waiting list (Subramanian 2009). Recently, it was observed that the survival rate at 1 and 3 years after listing were 81% and 55% in HIV infected vs. 91% and 82% in patients without HIV infection, respectively ( $p=0.005$ ) (Vibert 2011).

For these reasons, physicians attending HIV-positive patients with cirrhosis should follow patients prospectively and evaluate them early for OLT after the first clinical decompensation of liver disease. Similarly, patients whose cirrhosis is associated with HCC should also be evaluated (Llovet 2004). Both prevention and effective treatment of these complications may improve the likelihood of survival until OLT, and this should be performed also with the HIV-negative patients (Agüero 2007, Spengler 2011).

## Management of cirrhosis complications

Management of the complications of cirrhosis (portal hypertension, ascites, gastrointestinal bleeding, encephalopathy, SBP, HCC, and hepatorenal syndrome) must be planned, just as in the HIV-negative population (Arroyo 2008, EASL 2011, Spengler 2011, Bruix 2011). Medical management also includes prevention of

infection. In view of the short survival associated with the development of SBP, primary antibiotic prophylaxis with quinolones or trimethoprim-sulfamethoxazole should be considered (Fernández 2007).

It has been observed that transient elastometry could be used to select HIV/HCV-coinfected patients undergoing screening with upper gastrointestinal endoscopy for oesophageal varices (Pineda 2009). This study found that HIV/HCV-coinfected patients with cirrhosis who harbour oesophageal varices requiring preventive therapy for bleeding had liver stiffness values higher than those who did not require treatment. Liver stiffness values lower than 21 kPa were highly predictive of varices not at risk for bleeding.

As far as HCC is concerned, patients may benefit from more frequent imaging, i.e., every 3 months (Bräu 2007). Treatment of HCC may not be successful, depending on the stage. Other issues that may delay the progression of liver disease, such as avoidance of hepatotoxic drugs (e.g., didanosine) and vaccination for hepatitis A and B, should be kept in mind.

## Substance abuse

Smoking has been linked to HCC (Kuper 2000) and increased hepatic fibrosis (Pessione 2001). It may also increase histological activity in chronic HCV patients irrespective of alcohol consumption (Hezode 2003).

According to one study (Rosenthal 2007), alcohol consumption was more frequent among coinfecting patients who died from ESLD (92%), and another study suggested that excess alcohol consumption increases HCV RNA levels (Cooper 2005).

In addition, daily cannabis smoking was significantly associated with the presence of moderate to severe fibrosis in patients with chronic HCV infection and those with hepatitis C cirrhosis should abstain from or reduce cannabis use (Ishida 2008).

## HCV/HBV management

Specific treatment for infection with HBV or HCV is possible, although more difficult, in patients with advanced cirrhosis, especially for HCV infection (Rockstroh 2008, GESIDA 2010).

One of the objectives when treating HCV-monoinfected patients with advanced liver cirrhosis using pegylated-interferon plus ribavirin is to obtain undetectable plasma HCV RNA levels at the time of OLT in order to reduce the risk of HCV recurrence posttransplant. One study (Everson 2005) using a low accelerating dosage regimen (LADR) of anti-HCV therapy in monoinfected patients on the OLT waiting list showed that 30 (24%) of 124 patients achieved a sustained virologic response (SVR) and 12 (80%) of 15 patients who were HCV RNA-negative before OLT remained HCV RNA-negative 6 months or more after transplantation. This approach has not yet been addressed in the HIV infection setting. Safety data is also available from the APRICOT substudy (Mauss 2004). Hepatic decompensation was observed only in HIV/HCV-coinfected patients with markers of advanced cirrhosis, and its incidence was 10.4% (14/134). However, 6 (43%) of the 14 patients died as a result of hepatic decompensation. Antiretroviral treatment with didanosine was an associated risk factor. In contrast, no hepatic decompensation was noted in HIV/HCV-coinfected patients without cirrhosis. Therefore, anti-HCV treatment

during the pretransplant evaluation or while patients are on the waiting list should be individualized (e.g., patients with Child-Turcotte-Pugh class A and HCC or genotypes 2/3) and patients must be monitored closely because of their high risk of hepatic decompensation and death. In this sense, the AADSL Practice Guidelines for HCV infection (Ghany 2009), state that HIV-infected patients with decompensated liver disease (CTP class B or C) should not be treated with peg-interferon + ribavirin, and should be considered candidates for liver transplantation (Grading IIa, C).

Promising results are available related to the new HCV protease inhibitors (telaprevir and boceprevir) in HCV-monoinfected patients. However, data from larger trials regarding the HIV/HCV-coinfected patient is lacking. Their role in this subset of patients is unknown.

Since HBV replication is a contraindication for OLT and only patients without HBV viraemia are accepted for OLT, treatment of this infection should be a priority. HIV-positive patients who require antiretroviral therapy and have chronic HBV infection can be treated with lamivudine (or emtricitabine) and tenofovir as part of their triple antiretroviral therapy (Rockstroh 2008, Soriano 2008, GESIDA 2010). Adefovir and tenofovir have proven useful against HBV and could be used in cases of resistance to lamivudine (Rockstroh 2008, Soriano 2008, GESIDA 2010). Recently, one study (Heathcote 2011) showed that tenofovir disoproxil fumarate (TDF) is safe and effective in the long-term management of patients with chronic hepatitis B.

## Combination antiretroviral therapy (HAART)

The role of HAART in the progression of liver disease and in overall mortality in HCV/HIV-coinfected patients remains controversial (Tedaldi 2003, Qurishi 2003). Nevertheless, permanent discontinuation of HAART was independently associated with risk of first hepatic decompensation and a poorer survival rate (Lopez-Díéguez 2011) and to increased risk of fibrosis progression (Thorpe 2011). Antiretroviral drug regimens should be carefully planned in persons with HIV and ESLD. These patients should follow general recommendations (GESIDA 2011, DHHS 2011) and their liver function must be closely monitored for signs of hepatotoxicity. Careful consideration of drug prescriptions and possible interactions is essential. Furthermore, some antiretroviral drugs may be contraindicated in cirrhotic patients (e.g., didanosine, nevirapine, full-dose ritonavir) and their dosing should be adjusted according to the degree of hepatic impairment (Wyles 2005, Back 2011, Tuset 2011).

Therapeutic drug monitoring (TDM) may be useful for efavirenz and protease inhibitors. Indinavir and atazanavir can increase unconjugated bilirubin levels by inhibiting UDP-glucuronosyltransferase. As total bilirubin is a component of both the Child-Turcotte-Pugh and MELD scores, results in patients taking these drugs should be interpreted with caution.

It is noteworthy that the newer antiretroviral drug raltegravir, which is not a substrate of CYP450, can be used in HIV-1 OLT recipients. One study (Tricot 2009) enrolled 13 patients with HIV-1 infection who underwent solid organ transplantation (8 liver and 5 kidney) and received raltegravir. The authors found a lack of significant interaction between raltegravir and calcineurin inhibitors that

allowed simplified management of immunosuppressive treatment, excellent tolerability, and no events related to outcome (acute rejection) or HIV infection. Therefore, the combination of two nucleos(t)ide reverse transcriptase inhibitors (tenofovir + emtricitabine or abacavir + lamivudine) + raltegravir is the antiretroviral regimen of choice in HIV-infected liver transplant recipients.

Finally, given the speed with which new antiretrovirals appear and thus new interactions, physicians should consult updated databases on drug interactions (Back 2011, Tuset 2011).

## Orthotopic liver transplant (OLT)

OLT is the only therapeutic option for patients with ESLD. HIV infection is not a contraindication for liver transplantation (Miró 2007, Stock 2007, Samuel 2008). There are 3 different classes of criteria for including HIV-positive patients on the liver transplant waiting list: liver disease, HIV infection, and other criteria.

### Liver disease criteria

These are the same as for the non-HIV-infected population; the main indication for OLT in HIV-positive patients is ESLD caused by HCV coinfection. Less frequent indications are HBV coinfection (either acute or ESLD) and liver cancer.

In the UK guidelines (O'Grady 2005), indications for liver transplantation include acute liver failure, decompensated liver disease - with ascites, encephalopathy (it is important to exclude HIV-related dementia), variceal bleeding that is difficult to manage with standard therapy, and poor liver function (albumin <30 g/l, INR >1.5, and elevated serum bilirubin >450 mmol/l) - and HCC detected during regular tumour surveillance. In the Eurotransplant region these criteria have been replaced by the MELD score. The criteria for liver transplantation in patients with HCC are as follows: no more than 3 tumour nodules, no nodule greater than 5 cm in diameter, absence of macroscopic portal vein invasion, and absence of recognizable extrahepatic disease.

A new indication for liver transplant in HIV+ patients has been described in a recent study (Tateo 2009) in which 3 patients underwent liver transplantation and the cause of ESLD was nodular regenerative hyperplasia (NRH). OLT is the only therapeutic option in cases of severe portal hypertension such as that observed in these patients.

### HIV infection criteria

Most liver transplant groups from Europe and North America use similar HIV criteria. These are summarized in Table 1 (O'Grady 2005, Grossi 2005, Miró 2007, Anonymous 2004).

### Clinical criteria

Some authors are in favour of withdrawing exclusion criteria for some opportunistic infections that can be effectively treated and prevented, such as tuberculosis, candidiasis, and *Pneumocystis jiroveci pneumonia* (Roland 2003, Neff 2004, Radecke 2005). In fact, the NIH-sponsored study has updated the inclusion criteria for opportunistic complications and only untreatable diseases continue to be an exclusion criteria for liver transplantation (e.g., progressive multifocal



leukoencephalopathy, chronic cryptosporidiosis, multidrug-resistant systemic fungal infections, primary CNS lymphoma, and visceral Kaposi's sarcoma) (Roland 2006).

**Table 1. HIV criteria for OLT in some European countries and the US.**

	Spain (Miró 2005)	Italy (Grossi 2005)	UK (O'Grady 2005)	US (Anon 2004)
<b>Previous C events</b>				
Opportunistic infections	Some*	None in the previous year.	None after ART-induced immunological reconstitution.	Some**
Neoplasms	No	No		No
<b>CD4 cell count/mm<sup>3</sup></b>	>100***	>200 or >100 if decompensated cirrhosis	>200 or >100 if portal hypertension	>100***
<b>Plasma HIV-1 RNA viral load BLD on HAART****</b>	Yes	Yes	Yes	Yes

\* In Spain, patients with previous tuberculosis, *Pneumocystis jiroveci pneumonia* (PCP) or esophageal candidiasis can be evaluated for OLT; \*\* In the US, PCP and esophageal candidiasis were not exclusion criteria; \*\*\* Patients with previous OIs should have >200 CD4 cells/mm<sup>3</sup>; \*\*\*\* If PVL was detectable, post-OLT suppression with HAART should be predicted in all patients. BLD, Below the level of detection

## Immunological criteria

All groups agree that the CD4+ lymphocyte count should be above 100 cells/mm<sup>3</sup> for OLT (Roland 2003, Neff 2004). This figure is lower than that for kidney transplantation (CD4 >200 cells/mm<sup>3</sup>), because patients with cirrhosis often have lymphopenia due to hypersplenism, which leads to a lower absolute CD4+ count, despite high CD4 percentages and good virologic control of HIV. In Spain and the US, the CD4+ count must be greater than 200 cells/mm<sup>3</sup> in patients with previous opportunistic infections (Miró 2005, Anonymous 2004).

In Italy (Grossi 2005) and the UK (O'Grady 2005) the CD4+ cut-off is 200 cells/mm<sup>3</sup>, unless patients have decompensated cirrhosis or portal hypertension. In these scenarios, they use the same CD4+ cell threshold as in Spain and the US (100 cells/mm<sup>3</sup>).

## Virologic criteria

The essential criterion for OLT is that the patient must be able to have effective, safe and long-lasting HAART during the post-transplant period (Neff 2004, Fung 2003). The ideal situation is one in which the patient tolerates HAART before transplant and is ready for the transplant with undetectable HIV viral load by ultra-sensitive techniques (<50 copies/ml). Some patients do not have an indication for HAART, as they are long-term non-progressors with no immunological criteria (CD4+ lymphocyte count above 350 cells/mm<sup>3</sup>) or clinical criteria to start HAART and a detectable plasma viral load. In this setting, it is unknown whether and when (pre-transplant or post-transplant) it would be beneficial to initiate HAART in order to reach an undetectable plasma viral load.

## Other criteria

To be included on the OLT waiting list, an HIV-infected patient must have a favourable psychiatric evaluation. One observational prospective study found that HIV-1-infected patients with ESLD improved on all the items of a psychometric score (MADRS) at the follow-up evaluation (Barbanti 2009). In this study, the score variation was 10.20 at baseline and 4.09 at follow-up ( $p < 0.001$ ).

Patients who actively consume drugs should not be placed on the waiting list. In Spain, patients must undergo a 2-year consumption-free period for heroin and cocaine (Miró 2005), and 6 months with no consumption of other drugs (e.g., alcohol). Patients who are on stable methadone maintenance programmes can be included and can continue on the maintenance programme after the procedure (Liu 2003). Finally, as is the case with any transplant candidate, HIV-positive patients must show an appropriate degree of social stability in order to ensure adequate care in the post-transplant period.

## Outcome of OLT in HIV-positive patients

Overall short-term survival rates of HIV-positive patients who undergo OLT have been reported to be similar to those of HIV-negative patients when there is no HCV coinfection (Ragni 2003, Neff 2003, Fung 2004, Norris 2004, De Vera 2006, Schreiber 2007, Vennarecci 2007, Duclos-Vallee 2008, Tateo 2009, Sioutis 2010, Coffin 2010, Antonini 2011, Cherian 2011) (Table 2).

HIV+ patients have not been shown to have an increased risk of post-operative complications or a higher incidence of opportunistic infections or tumours than HIV-negative patients (Samuel 2008). However, some concerns have lately arisen. Findings from a case-control study (81 HIV/HCV-coinfected liver transplant recipients vs. 213 control patients) found that coinfecting individuals were about twice as likely to have treated acute rejection than HCV-monoinfected patients (35% vs 18%,  $p = 0.001$ ) (Terrault, 2009). Moreover, a recent retrospective study (Cherian 2011) has observed a 12% (3/24) incidence of post-transplant hepatic artery thrombosis (HAT) while in people without HIV infection that number is around 4.4 % (Bekker 2009). The prothrombotic state associated with HIV and liver disease could be the underlying factor involved.

Regarding infections, it has been observed that bacterial infections are common in liver (43%) and kidney recipients (35%), whereas HCV infection was the only factor associated with an increased risk of bacterial infection (liver recipients only) (Blumberg 2008). A high rate of severe (43%) and opportunistic (11%) infections in a cohort of 84 HIV/HCV-coinfected patients who underwent liver transplantation has also been noted (Moreno 2011). Bacterial infections occurred in 38 patients (45%), CMV infection in 21 (25%), uncomplicated herpes virus infection in 13 (15%), and fungal infections in 16 patients (19%, 7 invasive cases). A pretransplant MELD score  $> 15$ , history of category C AIDS-defining event and non-tacrolimus based immunosuppression regimes were factors independently associated with severe infections. Further studies are needed in order to obtain more robust conclusions.

**Table 2. Liver transplantation in HIV-infected patients: main cohorts of cases ( $\geq 10$ ) in the late HAART era (2003-2011).**

Author	Year	Country	N <sup>o</sup> cases	Virus	Follow-up (months)	Survival
Ragni	2003	International	24	HCV-62%; HBV-29%	17	18 (75%)
Neff	2003	US	16	HCV or HVB	12	14 (87%)
Fung	2004	US	29	HCV-90%	18	20 (69%)
Norris	2004	UK	14	HCV-50%; HBV/OH-50%	12 19	2 (29%) 7 (100%)
De Vera	2006	US	27	HCV-100%	27	13 (48%)
Schreibman	2007	US	15	HCV-40%;HBV-33%	74	10 (67%)
Vennarecci	2007	Italy	12	HCV-91%	26	6 (50%)
Duclos-Vallée	2008	France	35	HCV-100%	44	22 (63%)
Roland	2008	US	11	HCV-55%; VHB-45%	36	7 (64%)
Tateo	2009	France	13	HBV-100%	32	13 (100%)
Sioutis	2010	Germany	26	HCV-58%; HBV-34%	30	17 (65%)
Coffin	2010	US	22	HBV-100%	42	19 (86%)
Antonini	2011	France	59	HCV-100%	Not reported	34 (58%)
Di Benedetto	2011	Italy	23	HCV-87%	24	13 (57%)
Baccarani	2011	Italy	27	HCV-78%	26	23 (85%)
Cherian	2011	UK	24	HCV-50%; HBV-33%	88	15 (71%)
Spanish study	2011	Spain	248	HCV-96%	50	193 (72%)

## HIV/HCV coinfection

Mid-term survival is affected by recurrent hepatitis C (de Vera 2006). After OLT, recurrence of HCV infection is universal, regardless of whether the patient is infected by HIV or not. In fact, it is currently the number one cause of death. Some studies have suggested that recurrence of HCV in coinfecting patients tends to be more severe and occurs earlier (de Vera 2006, Castells 2006, Antonini 2011). The outcomes of 27 coinfecting patients were compared to 54 HCV-monoinfected patients who underwent OLT (de Vera 2006). The researchers found that HIV-positive patients had a higher likelihood of developing cirrhosis or dying of an HCV-related complication than HIV-negative patients (RR=2.6; 95%CI, 1.06-6.35). Cumulative 1-, 3- and 5-year survival for coinfecting and monoinfected patients was 67% vs. 76%, 56% vs. 72%, and 33% vs. 72%, respectively ( $p=0.07$ ).

In a retrospective study (Mindikoglu 2008) in the US that enrolled 138 HIV-positive patients who underwent liver transplant during the HAART era (1996-2006), the rate of survival at years 2 and 3 was significantly lower in HIV-positive patients (70% and 60%) than in the general population ( $n=30,520$ ) (81% and 77%), although this difference was observed only in the HCV/HIV- and HBV/HIV-coinfecting groups. None of the 24 HIV-monoinfected recipients died. Therefore, liver transplant in HIV-positive patients does not have higher short-term mortality (1-2 years). Nevertheless, the management and outcome of HCV reinfection could affect survival in the medium term (3-5 years) and long term (5-7 years).

In France, data from 35 HIV/HCV-coinfected patients were analysed and compared with those of 44 HCV-monoinfected patients. Survival rates at 2 and 5 years were 81%/91% and 51%/73% in HIV/HCV-coinfected patients/HCV-monoinfected patients, respectively ( $p=0.004$ ) (Duclos-Vallée 2008).

In Spain, data from a multicentre case-control study show that survival of HIV/HCV-coinfected patients ( $N=84$ ) at 1 year was similar to that of HCV-monoinfected patients ( $N=252$ ) - 88% vs. 89% (NS) - but it was significantly lower at 3 and 5 years: 62% vs. 77% and 48% vs. 75%, respectively ( $p<0.01$ ). The variables independently associated with mortality were HCV genotype 1 infection, non-traumatic donor death, number of units of blood transfused during surgery, and development of invasive fungal infection after transplant (Miró 2009). However, a recent Italian case-control study (Baccarani 2011) that included 27 HIV-positive and 27 HIV-negative recipients found that patient survival at 1, 2, and 5 years were 88%, 83%, and 83% for HIV-positive patients vs. 100%, 73%, and 73% for HIV-negative patients ( $p=0.95$ ). The estimated graft survival rate at 1, 3 and 5 years was 92%, 87%, and 87% for HIV-positive patients vs. 95%, 88%, and 82% for HIV-negative patients ( $p=0.59$ ), respectively. The median follow-up was only 26 months (range 1-64) and 27 months (range 1-48) for HIV+ recipients and HIV-negative recipients ( $p=0.85$ ), respectively, and the aetiology of ESLD was HCV in most cases (78% vs. 67%, respectively).

In order to definitively answer the survival question, additional cohort studies analysing donor and recipient characteristics, issues related to the activity of both viruses and the efficacy and safety of antiviral therapies are necessary for determining the long-term prognosis of this procedure.

Rapid progression of HCV-related liver disease in HIV-positive recipients would represent a major drawback and would shorten life expectancy in this group of patients. In fact, it is currently the primary cause of death. A French study observed that progression to fibrosis ( $\geq F2$ ) was significantly higher in HIV-positive patients ( $p<0.0001$ ) (Duclos-Vallée 2008) and MELD was the only significant predictor of mortality, although donor age was of borderline significance ( $p=0.06$ ). 11 (19%) out of 59 patients who underwent OLT developed fibrosing cholestatic hepatitis (FCH) (Antonini 2011). Nine of them (82%) died of liver failure after developing FCH. Survival rate was significantly lower in the FCH group when compared to non-FCH patients: 26 vs 76 months ( $p=0.004$ ).

There is insufficient experience on the efficacy and safety of therapy with pegylated-interferon and ribavirin in coinfecting transplant patients. One study (Miró 2007) summarized the reports evaluating the effectiveness of treatment of HCV reinfection in OLT with pegylated-interferon + ribavirin (Fung 2004, de Vera 2006, Vennarecci 2007, Castells 2007, Duclos-Vallée 2008, Di Benedetto 2011, Miró 2011). These patients were treated when they had histological criteria. Only 29 (21.3%) out of 136 HCV/HIV-coinfected patients achieved an SVR. SVR-associated factors were investigated in 23 HIV/HCV-coinfected liver recipients and found that donor age  $<60$  years ( $p=0.02$ ), genotype other than 1 ( $p=0.001$ ), and use of cyclosporin A ( $p=0.002$ ) were independently associated with SVR (Krishnan 2008). New strategies are necessary to improve the outcome of HCV recurrence in this setting. In this sense, a German study showed that SVR was obtained in 6 out of 7 patients treated within the first 3 months after OLT (Emmelkamp 2007). The low accelerating dosage regimen (LADR) approach has recently been addressed in 10

coinfected patients who developed fibrosing cholestatic hepatitis after OLT (Antonini 2011). None of these patients displayed a sustained virological response while adverse effects were reported in all patients. Anemia was present in the vast majority of cases and 4 died in the context of the anti-HCV virus. Finally, 2 cases of spontaneous clearance of HCV RNA after OLT have been described. This phenomenon is very infrequent and its mechanism is not known (Bhagat 2008).

**Table 3. Summary of studies evaluating the effectiveness of the treatment of HCV reinfection in OLT with pegylated interferon + ribavirin.**

Author + Year of Publication	HIV/HCV coinfecting patients		Non-HIV HCV-monoinfected patients (Control Group)	
	No. of cases	SVR No. (%)	No. of cases	SVR No. (%)
Fung 2004	12	2 (17)	-	-
De Vera 2006 <sup>b</sup>	15	4 (27)	27	7 (28) <sup>c</sup>
Vennarecci 2007 <sup>d</sup>	9	1 (11)	-	-
Castells 2007 <sup>e</sup>	5	1 (20)	9	1 (11)
Duclos-Vallée 2008	19	3 (16)	20	15 (75)
Di Benedetto 2011	9	4 (44)	-	-
Spanish study 2011	67	14 (21)	-	-
Total	136	29 (21)	-	-

b, Most cases were genotype 1. Three patients were treated with classical interferon plus ribavirin; c, Rate of sustained virological response was not specified. Data show the rate of virologic response (clearance of HCV RNA from serum); d, The authors did not specify the type of interferon used; e, These patients were included in the Spanish study and were not taken into account for the overall response rate; f, 3/27 (11%) genotypes 1-4 and 6/13 (46%) genotypes 2-3. SVR: sustained virological response (modified from Miró 2007).

On the other hand, in two recent genome-wide association studies (Ge 2009, Thomas 2009), a single nucleotide polymorphism (rs12979860) 3 kilobases upstream of the IL28B gene, which encodes the type III interferon- $\lambda$ , was shown to be associated with natural clearance of HCV among HIV-negative individuals of both European and African ancestry and with more than a twofold difference in response to anti-HCV drug treatment with pegylated-interferon and ribavirin in HCV-monoinfected patients. In a Swiss study (Rauch 2010), this antiviral effect was stronger in patients with HCV genotypes 1 or 4. Similar results have been recently communicated in HCV/HIV-coinfecting patients (Rallon 2011). Moreover, IL28B polymorphisms predicted treatment response in HIV/HCV-coinfecting patients with prior relapse while only predicted response in prior nonresponders carrying HCV genotypes 1 or 4 (Labarga 2011). The role of IL28B polymorphisms of the donor and their impact on the natural history of HCV recurrence and response to antiviral therapy in liver transplant recipients is not yet known.

### HIV/HBV coinfection

Cohorts of HIV/HBV-coinfecting patients are not as large as those of HIV/HCV-infected patients. Nevertheless, the outcome of HBV infection after OLT is much better (Tateo 2009, Coffin 2010). The survival rate in the short and medium term in HBV/HIV-coinfecting patients is high and similar to that observed in HBV-monoinfected patients, probably due to the low incidence of HBV reinfection. A French study (Tateo 2009) that included 13 HIV/HBV-coinfecting patients (3 out of

6 patients with positive anti-HCV serology had HCV RNA detectable before OLT), revealed 100% graft and patient survival after a mean follow-up of 32 months. They compared outcomes of 22 HBV/HIV patients and 20 HBV monoinfected patients who underwent OLT (Coffin 2010). Cumulative patient and graft survival at one and three years was 85% in the coinfecting patients and 100% in the monoinfected group ( $p=0.08$ ).

## Hepatocellular carcinoma

Preliminary Italian data show good results in 7 HIV-1-infected patients with HCC who underwent OLT. They observed an 86% overall patient and graft survival rate after a mean follow-up of 8 months, and recommend OLT in HIV-infected patients with early stage HCC (Di Benedetto 2006, Di Benedetto 2008). The same authors found no recurrence in 7 HIV-1 OLT recipients after a median follow-up of 13 months (Di Benedetto 2008). Recently, data have published from a case (VIH+) control (VIH-) study of patients with HCC who underwent OLT (Vibert 2011). They observed that the proportion of patients who exceeded the Milan criteria were similar in both groups (4/21 (19%) vs. 17/65 (26%), respectively,  $p=0.5$ ) while no differences were seen in number of nodules, maximum diameter and microvascular invasion grade. Time on waiting list was similar (6.4 vs. 4.1 months, respectively  $p=0.2$ ). 16 out of 21 HIV-infected patients underwent OLT vs. 58 out of 65 in the control group. The survival rate at 1 and 3 years was 81% and 55% vs. 91% y 82% respectively ( $p=0.005$ ). These authors found a high rate of HCC recurrence in the case group 5/16 (30%) vs. 9/58 (15%) in the control group. Further studies with more patients and longer follow-up are needed to precisely define the recurrence rate in this setting.

## Liver retransplantation

The experience of liver retransplantation (re-OLT) in the HIV-infected population is scarce and most of the cases are mentioned in articles published with patients from a single center (de Vera 2006, Vogel 2005, Polard 2005). The incidence and outcome of liver retransplantation in patients with HIV infection is unknown. Currently, in people without HIV infection, re-OLT accounts for approximately 10% of all liver transplants (Pfitzmann 2007, Reese 2009) and overall post-retransplant patient survival rate is between 15 and 20 percentage points lower than the primary OLT survival rate (Carrión 2010), which is a concern due to the significant disparity between the number of patients waiting for their first OLT and the shortage of available organs. A recent report (Gastaca 2011) observed a 6.7% of re-OLT in a cohort of 227 patients with HIV infection. Overall survival (95% confidence interval) at 30 days, 1 year, and 3 years after re-LT for HIV-positive and HIV-negative patients was 93% (59%-99%) vs. 85% (78%-90%), 40% (13%-66%) vs. 72% (64%-78%), and 40% (13%-66%) vs. 64% (55%-71%), respectively ( $p=0.231$ ). More patients at risk are needed to provide more conclusive results.

## Conclusions

ESLD is an increasingly frequent clinical scenario in the setting of HIV/HCV-HBV coinfection, and its burden is expected to continue to increase.

Early diagnosis of ESLD complications is particularly important and should be actively monitored and treated. In general terms, the management of ESLD in HIV-positive patients should be the same as in those without HIV infection.

Physicians taking care of ESLD patients should follow them prospectively and evaluate them for OLT after the first clinical decompensation of liver disease.

OLT is a life-saving procedure in this population, and is safe and effective in patients with HBV infection. However, recurrence of HCV infection in coinfecting patients can affect both graft and patient survival in the medium- and long-term. Prospective and larger studies with a longer follow-up must be carried out in order to determine the benefit of OLT in this setting.

The members of the **Hospital Clinic OLT in HIV Working Group** are: JM Miró, A. Moreno, C. Manzano, M. Laguno, JL Blanco, J Mallolas, C. Cervera, M. Tuset, M. Monras, N. Freixa, J. Blanch, I. Perez, D. Paredes, J. Fuster, C. Fontdevila, JC García-Valdecasas, JM Gatell, A. Rimola, (Hospital Clinic – IDIBAPS. University of Barcelona, Barcelona); C. Tural and A. Jou (Hospital Germans Trias i Pujol, Badalona, Barcelona, Spain); and J. Murillas and M. Peñaranda (Hospital Son Dureta, Palma de Mallorca, Spain).

## References

- Agüero F, Laguno M, Moreno A, et al. Management of end-stage liver disease in HIV-infected patients. *Curr Op HIV/AIDS* 2007;2:474-81. ([Abstract](#))
- Alter M. Epidemiology of viral hepatitis and HIV co-infection. *J Hepatol* 2006;44:S6-S9. ([Abstract](#))
- Anonymous. Solid organ transplantation in the HIV-infected patient. *Am J Transplant* 2004;4:Suppl 10:83-8 ([Abstract](#))
- Antonini TM, Sebah M, Roque-Afonso AM, et al. Fibrosing cholestatic hepatitis in HIV/HCV co-infected transplant patients-usefulness of early markers after liver transplantation. *Am J Transplant* 2011;11:1686-95. ([Abstract](#))
- Baccarani U, Adani GL, Bragantini F, et al. Long-term outcomes of orthotopic liver transplantation in human immunodeficiency virus-infected patients and comparison with human immunodeficiency virus-negative cases. *Transplant Proc* 2011;43:1119-22. ([Abstract](#))
- Back D, Gibbons S. The University of Liverpool HIV drug interactions website. (Accessed November 15, 2011 at <http://www.hiv-druginteractions.org>.)
- Barbanti Silva V, Ferrara M, Mazzi F, et al. What is the biopsychosocial role of human immunodeficiency virus positivity in patients with end-stage liver disease who undergo orthotopic liver transplantation? *Transplant Proc* 2008;40:1910-2. ([Abstract](#))
- Berretta M, Garlassi E, Cacopardo B, et al. Hepatocellular carcinoma in HIV-infected patients: check early, treat hard. *Oncologist* 2011;16:1258-69. ([Abstract](#))
- Bekker J, Ploem S, de Jong KP. Early hepatic artery thrombosis after liver transplantation: a systematic review of the incidence, outcome and risk factors. *Am J Transplant* 2009;9:746-57. ([Abstract](#))
- Benhamou Y, Di Martino V, Bochet M, et al. Factors affecting liver fibrosis in human immunodeficiency virus-and hepatitis C virus-coinfected patients: impact of protease inhibitor therapy. *Hepatology* 2001;34:283-7. ([Abstract](#))
- Bhagat V, Foont J, Schiff E, et al. Spontaneous Clearance of Hepatitis C Virus After Liver Transplantation in Two Patients Coinfected with Hepatitis C Virus and Human Immunodeficiency Virus. *Liver Transpl* 2008;14:92-5. ([Abstract](#))
- Blumberg E, Barin B, Olthoff K, et al. Bacterial Infections in HIV Positive Transplant Recipients. American Transplant Congress. May 31- June 4 2008. Toronto Canada. Abstract# 17.

## 400 Hepatology 2012

- Brau N, Fox RK, Xiao P, et al. Presentation and outcome of hepatocellular carcinoma in HIV-infected patients: a U.S.-Canadian multicenter study. *J Hepatol* 2007;47:527-37 ([Abstract](#))
- Bruno R, Puoti M, Sacchi P, et al. Management of hepatocellular carcinoma in human immunodeficiency virus-infected patients. *J Hepatol* 2006;44:S146-S150. ([Abstract](#))
- Bruix J, Sherman M; American Association for the Study of Liver Diseases. Management of hepatocellular carcinoma: an update. *Hepatology* 2011;53:1020-2. ([Abstract](#))
- Cardenas A, Gines P. Management of complications of cirrhosis in patients awaiting liver transplantation. *J Hepatol* 2005;42:S124-S133. ([Abstract](#))
- Carrión JA, Navasa M, Forns X. Retransplantation in patients with hepatitis C recurrence after liver transplantation. *J Hepatol* 2010;53:962-70. ([Abstract](#))
- Castells L, Escartin A, Bilbao I, et al. Liver Transplantation in HIV-HCV Coinfected Patients: A Case-Control Study. *Transplantation* 2007;83:354-8. ([Abstract](#))
- Castells L, Esteban J, Bilbao I, et al. Early antiviral treatment of hepatitis C virus recurrence after liver transplantation in HIV-infected patients. *Antiviral Therapy* 2006;11:1061-70. ([Abstract](#))
- Chan A, Poo R, Ng K, et al. Changing Paradigm in the Management of Hepatocellular Carcinoma Improves the Survival Benefit of Early Detection by Screening. *Ann Surg* 2008;247:666-73. ([Abstract](#))
- Cherian PT, Alrabih W, Douiri A, et al. Liver transplantation in human immunodeficiency virus-infected patients: Procoagulant, but is antithrombotic prophylaxis required? *Liver Transpl* 2012;18:82-8 ([Abstract](#))
- Coffin CS, Stock PG, Dove LM, et al. Virologic and clinical outcomes of hepatitis B virus infection in HIV-HBV coinfecting transplant recipients. *Am J Transplant* 2010;10:1268-75. ([Abstract](#))
- Cooper C, Cameron DW: Effect of alcohol use on the impact of effective antiretroviral therapy for HIV coinfection on plasma HCV levels. *Clin Infect Dis* 2005;41:S105-9. ([Abstract](#))
- Crum NF, Riffenburgh RH, Wegner S, et al. Comparisons of causes of death and mortality rates among HIV-infected persons: analysis of the pre, early, and late HAART (highly active antiretroviral therapy) eras. *J Acquir Immune Defic Syndr* 2006;41:194-200.
- de Vera ME, Dvorchik I, Tom K, et al. Survival of liver transplant patients coinfecting with HIV and HCV is adversely impacted by recurrent Hepatitis C. *Am J Transplant* 2006;6:2983-93. ([Abstract](#))
- Di Benedetto F, De Ruvo N, Berretta N, et al. Hepatocellular carcinoma in HIV patients treated by liver transplantation. *EJSO* 2008;34: 422-7. ([Abstract](#))
- Di Benedetto F, De Ruvo N, Berretta M, et al. Don't deny liver transplantation to HIV patients with hepatocellular carcinoma in the highly active antiretroviral therapy era. *J Clin Oncol* 2006;24:26-7. ([Abstract](#))
- Di Benedetto F, Tarantino G, De Ruvo N, et al. University of Modena experience in HIV-positive patients undergoing liver transplantation. *Transplant Proc* 2011;43:1114-8. ([Abstract](#))
- DHHS Panel on Antiretroviral Guidelines for Adults and Adolescents. Guidelines for the use of antiretroviral agents in HIV-1-infected adults and adolescents. Department of Health and Human Services. October 14, 2011; 1-167. (Accessed November 5, 2011 at <http://www.aidsinfo.nih.gov/ContentFiles/AdultandAdolescentGL.pdf>).
- Duclos-Vallée J, Féray C, Sebagh M, et al. Survival and recurrence of hepatitis C after liver transplantation in patients coinfecting with human immunodeficiency virus and hepatitis C virus. *Hepatology* 2008;47:407-17. ([Abstract](#))
- European Association for the Study of the Liver. EASL clinical practice guidelines on the management of ascites, spontaneous bacterial peritonitis, and hepatorenal syndrome. *J Hepatol* 2010;53:397-417. ([Abstract](#))
- Emmelkamp J, Guaraldi G, Cocchi S, et al. Antiviral therapy for HCV-recurrence after liver transplantation in HIV/HCV-infected individuals. 11th European AIDS Conference/EACS. October 2007, Madrid.
- Everson G. Treatment of Hepatitis C in Patients Who Have Decompensated Cirrhosis. *Clin Liver Dis* 2005;9:473- 86. ([Abstract](#))
- Fernández J, Navasa M, Planas R, et al. Primary prophylaxis of spontaneous bacterial peritonitis delays hepatorenal syndrome and improves survival in cirrhosis. *Gastroenterology* 2007;133:818-24. ([Abstract](#))
- Fung J, Eghtesad B, Patel-Tom K, DeVera M, Chapman H, Ragni M. Liver transplantation in patients with HIV infection. *Liver Transpl* 2004;10:Suppl 2:S39-S53. ([Abstract](#))



- Fung LT, Roland ME, Stock PG. Review of solid-organ transplantation in HIV-infected patients. *Transplantation* 2003;75:425-9. ([Abstract](#))
- Gastaca M, Agüero F, Montejo M, et al. Retransplantation in HIV?Infected Patients after Liver Transplantation: A Prospective Cohort Study." American Transplant Congress 2011, Philadelphia, PA, April 30 ? May 4, 2011, Abstract 826.
- Ge D, Fellay J, Thompson AJ, et al. Genetic variation in IL28B predicts hepatitis C treatment-induced viral clearance. *Nature* 2009;461:399-401 ([Abstract](#))
- GESIDA, Panel de expertos, Secretaría del Plan Nacional sobre el Sida (SPNS) y Asociación Española para el Estudio del Hígado (AEEH). [Recommendations of Gesida/PNS/AEEH for the management and treatment of the adult patient co-infected with HIV and hepatitis A, B and C virus]. *Enferm Infecc Microbiol Clin* 2010 ;28:31.e1-31.
- GESIDA, Panel de expertos y Plan Nacional sobre el Sida. National consensus document by GESIDA/National Aids Plan on antiretroviral treatment in adults infected by the human immunodeficiency virus (January 2011 update)]. *Enferm Infecc Microbiol Clin* 2011;29:209.e1-103. ([Abstract](#))
- Ghany M, Strader D, Thomas D, Seeff LB, American Association for the Study of Liver Diseases. Diagnosis, Management, and Treatment of Hepatitis C: An Update. *Hepatology* 2009;49:1335-74.
- Graham CS, Baden LR, Yu E, et al. Influence of human immunodeficiency virus infection on the course of hepatitis C virus infection: a meta-analysis. *Clin Infect Dis* 2001;33:562-9 ([Abstract](#))
- Grossi PA, Tumietto F, Costigliola P, et al. Liver Transplantation In HIV-Infected Individuals: Results Of The Italian National Program. *Transplant International* 2005;18:S11.
- Heathcote EJ, Marcellin P, Buti M, et al. Three-year efficacy and safety of tenofovir disoproxil fumarate treatment for chronic hepatitis B. *Gastroenterology* 2011;140:132-43. ([Abstract](#))
- Hezode C, Lonjon I, Roudot-Thoraval F, et al. Impact of smoking on histological liver lesions in chronic hepatitis C. *Gut* 2003;52:126-9 ([Abstract](#))
- Ishida JH, Peters MG, Jin C, et al. Influence of cannabis use on severity of hepatitis C disease. *Clin Gastroenterol Hepatol* 2008;6:69-75. ([Abstract](#))
- Joshi D, O'Grady J, Dieterich D, Gazzard B, Agarwal K. Increasing burden of liver disease in patients with HIV infection. *Lancet* 2011;377:1198-209. ([Abstract](#))
- Konopnicki D, Mocroft A, de Wit S, et al. Hepatitis B and HIV: prevalence, AIDS progression, response to highly active antiretroviral therapy and increased mortality in the EuroSIDA cohort. *AIDS* 2005;19:593-601. ([Abstract](#))
- Krishnan K, Poordad F, Reddy R, et al. Safety and Efficacy of Antiviral Therapy in Hepatitis C Virus (HCV)-Human Immunodeficiency Virus (HIV) Coinfected Liver Transplant Recipients: Preliminary HIVTR Results. American Transplant Congress 2008. May 31- June 4 2008. Toronto Canada. Abstract# 1618
- Kuper H, Tzonou A, Kalamani E, et al. Tobacco smoking, alcohol consumption and their interaction in the causation of hepatocellular carcinoma. *Int J Cancer* 2000;85:498-502. ([Abstract](#))
- Labarga P, Barreiro P, Mira JA, et al. Impact of IL28B polymorphisms on response to peginterferon and ribavirin in HIV-hepatitis C virus-coinfected patients with prior nonresponse or relapse. *AIDS* 2011;25:1131-3. ([Abstract](#))
- Lewden C, Salmon D, Morlat P, et al. Causes of death among human immunodeficiency virus (HIV)-infected adults in the era of potent antiretroviral therapy: emerging role of hepatitis and cancers, persistent role of AIDS. *Int J Epidemiol* 2005;34:121-30. ([Abstract](#))
- Liu LU, Schiano TD, Lau N, et al. Survival and risk of recidivism in methadone-dependent patients undergoing liver transplantation. *Am J Transplant* 2003;3:1273-7. ([Abstract](#))
- Lopez-Dieguez M, Montes ML, Pascual-Pareja JF, et al. The natural history of liver cirrhosis in HIV-hepatitis C virus-coinfected patients. *AIDS* 2011;25:899-904 ([Abstract](#))
- Llovet JM, Fuster J, Bruix J. The Barcelona approach: diagnosis, staging, and treatment of hepatocellular carcinoma. *Liver Transpl* 2004;10:Suppl 1: S115-S120. ([Abstract](#))
- Maida I, Nunez M, Gonzalez-Lahoz J, Soriano V. Liver transplantation in HIV-HCV coinfected candidates: what is the most appropriate time for evaluation? *AIDS Res Hum Retroviruses* 2005;21:599-601. ([Abstract](#))
- Martinez E, Milinkovic A, Buirra E, et al. Incidence and causes of death in HIV-infected persons receiving highly active antiretroviral therapy compared with estimates for the general

## 402 Hepatology 2012

- population of similar age and from the same geographical area. *HIV Medicine* 2007;8:251-258.
- Mauss S, Valenti W, DePhamphilis J. Risk factors for hepatic decompensation in patients with HIV/HCV coinfection and liver cirrhosis during interferon-based therapy. *AIDS* 2004; 18:F21-F25. (Abstract)
- Merchante N, Giron-Gonzalez JA, Gonzalez-Serrano M, et al. Survival and prognostic factors of HIV-infected patients with HCV-related end-stage liver disease. *AIDS* 2006;20:49-57. (Abstract)
- Mindikoglu A, Regev A, Magder L. Impact of human immunodeficiency virus on survival after liver transplantation: analysis of United Network for Organ Sharing database. *Transplantation* 2008;85:359-68. (Abstract)
- Miro JM, Agüero F, Laguno M, et al. Liver transplantation in HIV/Hepatitis coinfection. *J HIV ther* 2007;12:24-35. (Abstract)
- Miró JM, Montejo M, Castells L, et al. 5-year survival of HCV-HIV coinfecting liver transplant recipients (OLT): a case control study. 16th Interscience Conference on Antimicrobial Agents and Chemotherapy (CROI). Montreal, 2009. Abstract H-124.
- Miro JM, Torre-Cisnero J, Moreno A, et al. [GESIDA/GESITRA-SEIMC, PNS and ONT consensus document on solid organ transplant (SOT) in HIV-infected patients in Spain (March, 2005)]. *Enferm Infecc Microbiol Clin* 2005;23:353-62. (Abstract)
- Miró J, Castells L, Valdivieso A, et al, and the Spanish OLT in HIV-Infected Patients Working Group. Treatment with Pegylated Interferon (PEG-INF) plus Ribavirin (RBV) of 67 HIV-infected Patients with Recurrent Hepatitis C Virus (HCV) Infection after Liver Transplantation (OLT): Results of the FIPSE OLT-HIV-Cohort Study (2002-08). 18th Conference on Retroviruses and Opportunistic Infections (CROI 2011), Poster Q-188.
- Miro JM, Agüero F, Rimola A. HIV and liver transplantation: challenges and options. Gines P editor. *Therapy in liver disease*. Barcelona: Elsevier Doyma, 2011. p. 367-76.
- Mohsen AH, Easterbook PJ, Taylor C, et al. Impact of human immunodeficiency virus (HIV) on the progression of liver fibrosis in Hepatitis C virus infected patients. *Gut* 2003; 52:1035-40. (Abstract)
- Moreno A, Cervera C, Fortun J, et al. Epidemiology and outcome of infections in human immunodeficiency virus/hepatitis c virus-coinfecting liver transplant recipients: A FIPSE/GESIDA Prospective Cohort Study. *Liver Transpl* 2012;18:70-81. (Abstract)
- Neff GW, Bonham A, Tzakis AG et al. Orthotopic liver transplantation in patients with human immunodeficiency virus and end-stage liver disease. *Liver Transpl* 2003;9:239-47. (Abstract)
- Neff GW, Sherman KE, Egtesad B, Fung J. Review article: current status of liver transplantation in HIV-infected patients. *Aliment Pharmacol Ther* 2004;20:993-1000. (Abstract)
- Norris S, Taylor C, Muesan P, et al. Outcomes of liver transplantation in HIV-infected individuals: the impact of HCV and HBV infection. *Liver Transpl* 2004;10:1271-8. (Abstract)
- O'Grady J, Taylor C, Brook G. Guidelines for liver transplantation in patients with HIV infection (2005). *HIV Med* 2005;6:Suppl 2:149-53. (Abstract)
- Palella FJ Jr, Baker RK, Moorman AC, et al. Mortality in the highly active antiretroviral therapy era: changing causes of death and disease in the HIV outpatient study. *J Acquir Immune Defic Syndr* 2006;43:27-34. (Abstract)
- Pessione F, Ramond MJ, Njapoum C, et al. Cigarette smoking and hepatic lesions in patients with chronic hepatitis C. *Hepatology* 2001;34:121-5. (Abstract)
- Pfizzmann R, Benschmidt B, Langrehr JM, et al. Trends and experiences in liver retransplantation over 15 years. *Liver Transpl* 2007;13:248-57 (Abstract)
- Pineda JA, Aguilar-Guisado M, Rivero A, et al. Natural history of compensated hepatitis C virus-related cirrhosis in HIV-infected patients. *Clin Infect Dis* 2009;49:1274-82. (Abstract)
- Pineda JA, Recio E, Camacho A, et al. Liver stiffness as a predictor of esophageal varices requiring therapy in HIV/hepatitis C virus-coinfecting patients with cirrhosis. *J Acquir Immune Defic Syndr* 2009;51:445-9. (Abstract)
- Pineda JA, Romero-Gomez M, Diaz-Garcia F, et al. HIV coinfection shortens the survival of patients with hepatitis C virus-related decompensated cirrhosis. *Hepatology* 2005; 41:779-89. (Abstract)

- Polard E, Camus C, Abault AY, et al. Retransplantation for acute liver failure due to combined antiviral agents in an HIV-HCV coinfecting liver transplant recipient. *Transplantation* 2005;80:1136-8. ([Abstract](#))
- Poynard T, Mathurin P, Lai CL, et al. A comparison of fibrosis progression in chronic liver diseases. *J Hepatol* 2003;38:257-65. ([Abstract](#))
- Prieto J, Laguno M, Agüero F, et al. Evaluation of cirrhotic patients with HIV infection (HIV+) as candidates for liver transplantation. *Liver transplantation* 2008;14:S223.
- Puoti M, Bruno R, Soriano V, et al. Hepatocellular carcinoma in HIV-infected patients: epidemiological features, clinical presentation and outcome. *AIDS* 2004;18:2285-93. ([Abstract](#))
- Qurishi N, Kreuzberg C, Luchters G, et al. Effect of antiretroviral therapy on liver-related mortality in patients with HIV and hepatitis C virus coinfection. *Lancet* 2003;362:1708-13. ([Abstract](#))
- Radecke K, Fruhauf NR, Miller M, et al. Outcome after orthotopic liver transplantation in five HIV-infected patients with virus hepatitis-induced cirrhosis. *Liver Int* 2005;25:101-8. ([Abstract](#))
- Ragni MV, Belle SH, Im K, et al. Survival of human immunodeficiency virus-infected liver transplant recipients. *J Infect Dis* 2003;188:1412-20. ([Abstract](#))
- Ragni MV, Eghtesad B, Schlesinger KW, et al. Pretransplant survival is shorter in HIV-positive than HIV-negative subjects with end-stage liver disease. *Liver Transpl* 2005;11:1425-30. ([Abstract](#))
- Rallon N, Soriano V, Naggie S, et al. IL28B gene polymorphisms and viral kinetics in HIV/hepatitis C virus-coinfecting patients treated with pegylated interferon and ribavirin. *AIDS* 2011;25:1025-33. ([Abstract](#))
- Rauch A, Kutalik Z, Descombes P, et al. Genetic variation in IL28B is associated with chronic hepatitis C and treatment failure: a genome-wide association study. *Gastroenterology* 2010;138:1338-45. ([Abstract](#))
- Reese PP, Yeh H, Thomasson AM, et al. Transplant center volume and outcomes after liver retransplantation. *Am J Transplant* 2009;9:309-17. ([Abstract](#))
- Rockstroh J, Bhagani S, Benhamo Y, et al. EACS Executive Committee European AIDS Clinical Society (EACS) guidelines for the clinical management and treatment of chronic hepatitis B and C coinfection in HIV-infected adults. *HIV Med* 2008;9:82-8. ([Abstract](#))
- Rockstroh JK, Mocroft A, Soriano V, et al. Influence of hepatitis C virus infection on HIV-1 disease progression and response to highly active antiretroviral therapy. *J Infect Dis* 2005;192:992-1002. ([Abstract](#))
- Roland M, Stock PG. Liver Transplantation in HIV-Infected Recipients. *Seminars in Liver Disease* 2006;26:273-84. ([Abstract](#))
- Roland ME, Stock PG. Review of solid-organ transplantation in HIV-infected patients. *Transplantation* 2003;75:425-9. ([Abstract](#))
- Roland ME, Barin B, Carlson L, et al. HIV-infected liver and kidney transplant recipients: 1- and 3-year outcomes. *Am J Transplant* 2008;8:355-65. ([Abstract](#))
- Rosenthal E, Pialoux G, Bernard N, et al. Liver-related mortality in human-immunodeficiency-virus-infected patients between 1995 and 2003 in the French GERMIVIC Joint Study Group Network (MORTAVIC 2003 Study). *J Viral Hepat* 2007; 14:183-88. ([Abstract](#))
- Salmon-Ceron D, Rosenthal E, Lewden C, et al. Emerging role of hepatocellular carcinoma among liver-related causes of deaths in HIV-infected patients: The French national Mortalité 2005 study. *J Hepatol* 2009;50:736-45. ([Abstract](#))
- Samuel D, Weber R, Stock P, et al. Are HIV-infected patients candidates for liver transplantation? *J Hepatol* 2008;48:697-707. ([Abstract](#))
- Schreibman I, Gaynor J, Jayaweera D, et al. Outcomes after orthotopic liver transplantation in 15 HIV-infected patients. *Transplantation* 2007;84:697-705. ([Abstract](#))
- Shaw E, Castellote J, Santin M, et al. Clinical features and outcome of spontaneous bacterial peritonitis in HIV-infected cirrhotic patients: a case-control study. *Eur J Clin Microbiol Infect Dis* 2006;25:291-8. ([Abstract](#))
- Sioutis M, Anadol E, Rockstroh J, et al. Outcome after orthotopic liver transplantation in 26 human immunodeficiency virus (HIV) - positive patients in Germany: Recurrence of chronic hepatitis-C infection after transplantation. *British Journal of Surgery* 2010;97: S32 [Abstr].

## 404 Hepatology 2012

- Soriano V, Puoti M, Peters M, et al. Care of HIV patients with chronic hepatitis B: updated recommendations from the HIV-Hepatitis B Virus International Panel. *AIDS* 2008;22:1399-410. ([Abstract](#))
- Stock P, Roland M. Evolving clinical strategies for transplantation in the HIV-positive recipient. *Transplantation* 2007;84:563-71. ([Abstract](#))
- Spengler U. Management of end-stage liver disease in HIV/hepatitis C virus co-infection. *Curr Opin HIV AIDS* 2011;6:527-33. ([Abstract](#))
- Subramanian A, Sulkowski M, Barin B, et al. MELD score is an important predictor of pretransplantation mortality in HIV-infected liver transplant candidates. *Gastroenterology* 2010;138:159-64. ([Abstract](#))
- Tateo M, Roque-Afonso AM, Antonini TM, et al. Long-term follow-up of liver transplanted HIV/hepatitis B virus coinfecting patients: perfect control of hepatitis B virus replication and absence of mitochondrial toxicity. *AIDS* 2009;23:1069-76. ([Abstract](#))
- Tateo M, Sebah M, Bralet MP, et al. A new indication for liver transplantation: nodular regenerative hyperplasia in human immunodeficiency virus-infected patients. *Liver Transpl* 2008;14:1194-8. ([Abstract](#))
- Tedaldi EM, Baker RK, Moorman AC, et al. Influence of coinfection with hepatitis C virus on morbidity and mortality due to human immunodeficiency virus infection in the era of highly active antiretroviral therapy. *Clin Infect Dis* 2003;36:363-7. ([Abstract](#))
- Terrault N, Barin B, Schiano T, et al. Survival and Risk of Severe Hepatitis C Virus (HCV) Recurrence in Liver Transplant (LT) Recipients Coinfected with Human Immunodeficiency Virus (HIV) and HCV. 60th Annual Meeting of the American Association for the Study of Liver Diseases (AASLD 2009), Boston USA, October 30- November 1, 2009, Abstract 195.
- D:A:D, The Data Collection on Adverse Events of Anti-HIV Drugs Study group. Liver-related deaths in persons infected with the human immunodeficiency virus, The D:A:D Study. *Arch Intern Med* 2006;166:1632-41. ([Abstract](#))
- Thomas DL, Thio CL, Martin MP, Qi Y, Ge D, O'Huigin C, et al. Genetic variation in IL28B and spontaneous clearance of hepatitis C virus. *Nature* 2009;461:798-801. ([Abstract](#))
- Thorpe J, Saeed S, Moodie EE, Klein MB. Antiretroviral treatment interruption leads to progression of liver fibrosis in HIV-hepatitis C virus co-infection. *AIDS* 2011;25:967-75. ([Abstract](#))
- Tricot L, Teicher E, Peytavin G, Zucman D, Conti F and Calmus Y. Safety and efficacy of Raltegravir in HIV-infected transplant patients cotreated with immunosuppressive drugs. *Am J Transplant* 2009;9:1-7. ([Abstract](#))
- Tuset M, Miró JM, Codina C, Ribas J, Ed. Guía de interacciones en HIV. (Accessed November 15, 2011 at <http://www.interaccionesHIV.com>.)
- Vennarecci G, Ettorre GM, Antonini M, et al. Liver transplantation in HIV-positive patients. *Transplant Proc* 2007;39:1936-8. ([Abstract](#))
- Vibert E, Duclos-Vallée JC, Ghigna MR, et al. Liver transplantation for hepatocellular carcinoma: The impact of human immunodeficiency virus infection. *Hepatology* 2011;53:475-82
- Vogel M, Voigt E, Schäfer N, et al. Orthotopic liver transplantation in human immunodeficiency virus (HIV)-positive patients: outcome of 7 patients from the Bonn cohort. *Liver Transpl* 2005;11:1515-21 ([Abstract](#))
- Wyles DL, Gerber J. Antiretroviral drug pharmacokinetics in hepatitis with hepatic dysfunction. *Clin Infect Dis* 2005;40:174-81. ([Abstract](#))

## 24. Metabolic Liver Diseases: Hemochromatosis

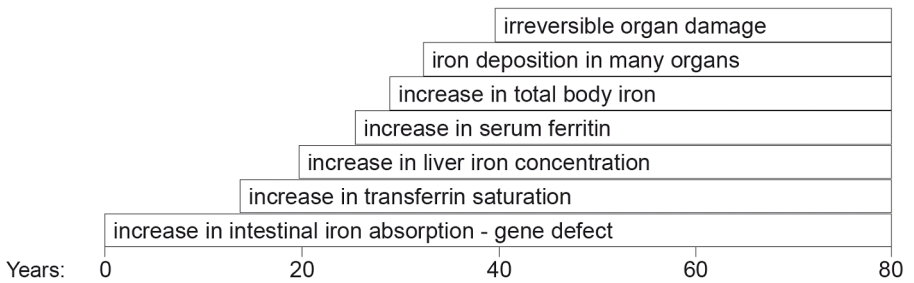
*Claus Niederau*

### **Definition and classification of iron overload diseases**

Hereditary hemochromatosis is classified into 4 subtypes (Table 1). Type 1 is the well known form of iron overload due to an autosomal-recessive genetic metabolic malfunction; the homozygous C282Y mutation of the HFE gene on chromosome 6 accounts for more than 90% of clinical phenotypes in populations of Caucasian origin (Feder 1996). The mutation leads to an inadequately high intestinal iron absorption that after decades may cause iron overload and damage to various organs (Figure 1). Types 2a and 2b of genetic hemochromatosis are juvenile forms of iron overload that lead to a severe outcome prior to age 30, with cardiomyopathy and hypogonadism. The corresponding mutations are located in the hemojuveline and hepcidin genes, respectively (Roetto 1999). Type 3 has mainly been described in Italian families and refers to a mutation in the transferrin receptor 2 gene (Girelli 2002). Clinical consequences of type 3 hemochromatosis are similar to type 1. Types 2 and 3 are autosomal-recessive traits. The mutations of the autosomal-dominant type 4 hemochromatosis are located in the gene coding for the basolateral iron transporter ferroportin 1 (Njajou 2001). In contrast to the other types, iron is accumulated in type 4 mainly in macrophages; ferritin values are markedly elevated although transferrin saturation is only slightly higher.

Secondary hemochromatosis is usually caused by multiple blood transfusions in hemolytic anemias such as thalassemia, sickle cell anemia and myelodysplasia syndrome. Iron first accumulates in RES macrophages and is later transferred to parenchymal cells. With frequent blood transfusions, iron may accumulate faster than with genetic hemochromatosis; iron overload often leads to severe cardiomyopathy and liver cirrhosis, limiting effective prognosis. Therapy consists of iron chelators because phlebotomies cannot be done due to the underlying anemia. This review will focus on type 1 HFE hemochromatosis, the most prevalent genetic form in Germany. Most consequences of iron overload are similar, whatever the

cause. Thus, the pathophysiology of tissue and organ damage by iron excess is discussed in detail only for HFE hemochromatosis.



**Figure 1. Scheme of natural history of type 1 genetic hemochromatosis.**

**Table 1. Classification of hemochromatosis.**

<b>I) Genetic hemochromatosis</b>				
<b>Types</b>	<b>Gene defect on</b>	<b>Affected gene</b>	<b>Inheritance</b>	<b>High prevalence</b>
Type 2a	Chromosome 1	Hemojuveline	Autosomal-recessive	Juvenile form
Type 2b	Chromosome 19	Hepcidin	Autosomal-recessive	Juvenile form
Type 3	Chromosome 7	Transferrin receptor 2	Autosomal-recessive	Italy
Type 4	Chromosome 2	Ferroportin 1	Autosomal-dominant	Italy
Neonatal	Unknown	Unknown	Unknown	Very rare
Others	Unknown	Unknown	Unknown	Of non-Caucasian origin
<b>II) Secondary hemochromatosis</b>				
a) Chronic anemias (thalassemia, sickle cell disease, MDS, other rare hemolytic anemias)				
b) Multiple blood transfusions in general				
c) Long-term oral intake of high amounts of iron (diet-related or IV)				
<b>III) Non-classified, ill-defined iron overload syndromes</b>				
a) iron overload in Bantu Africans				
b) iron overload in aceruloplasminemia				

## Type 1 HFE hemochromatosis

### History

The association between liver cirrhosis, pigment deposits in the liver, and diabetes mellitus was recognized over a century ago (Trosseau 1865, Troisier 1871, Hanot

and Schachmann 1886). The term hemochromatosis was first introduced in the 19<sup>th</sup> century (Recklinghausen 1889), but was not generally accepted until used as the title of a classic monograph (Sheldon 1935). The controversy over whether hemochromatosis was merely a form of alcoholic liver cirrhosis (MacDonald 1960) or a genetic error of iron metabolism (Sheldon 1935, Crosby 1966) lasted almost a century until the association between special HLA haplotypes and hemochromatosis which recognized the genetic nature of the disease was described (Simon 1975). The mode of inheritance was identified as an autosomal recessive disorder (Simon 1977). Finally, the major mutation on the HFE gene associated with clinical manifestations was identified (Feder 1996).

## Epidemiology

Type 1 hemochromatosis is probably the most prevalent genetic metabolic error in Caucasian populations (Adams 2005). The prevalence of C282Y homozygotes is approximately 0.5% in central Europe and in the Caucasian population of North America; the prevalence of C282Y and H63D heterozygotes approaches 40% in similar populations (Adams 2005). Phenotypic expression also depends on several non-genetic factors such the amount of dietary iron and blood loss (Figure 2). For example, females develop clinical consequences of iron overload 5-8 times less frequently and 10-20 years later than males due to menses. It is now widely accepted that not all C282Y homozygous men will develop the full clinical manifestation of hemochromatosis. It is unknown, however, whether 5% or 50% will show clinical disease during their lifetime and what factors determine that phenotype-

As mentioned previously, the homozygous C282Y mutation accounts for more than 90% of the clinical phenotype in Caucasian populations (Feder 1996, Adams 2005) (Table 2). A point mutation at H63D is also frequently identified in the HFE gene as well as other less frequent mutations. None of these gene alterations or polymorphisms, found in up to 40% of Caucasians, correlates with the phenotype. A subject with a C282Y variation on one allele and a H63D variation on the other is called a "compound heterozygote" (Table 2). Only a small percentage of such compound heterozygotes are at risk for clinical consequences of iron overload. C282Y and H63D heterozygotes are at no risk of iron overload (Table 2). In non-Caucasian populations other genes may be involved in causing iron overload.

## Etiology and pathogenesis

Intestinal iron absorption and iron losses are finely balanced under physiological conditions. Approximately 10% of the total daily intake (10-20 mg) is absorbed by the small intestine (1-2 mg). However, subjects with the homozygous C282Y mutation may absorb up to 20% of iron intake; i.e., up to 2-4 mg/day. Thus, homozygotes have an excessive iron intake of approximately 1 mg/day. It may therefore take several decades until iron stores approach 10 g above which organ damage is considered to be induced. Many patients at the clinical end stage of hemochromatosis, including liver cirrhosis and diabetes mellitus, have total body iron stores of 20-30 g. Their intestinal iron absorption is downregulated when iron stores increase, as it is in patients with genetic hemochromatosis. This downregulation, however, occurs on an increased level when compared to subjects without the HFE gene mutation. Correspondingly, intestinal iron absorption is

massively increased in patients with hemochromatosis when iron stores have been depleted by phlebotomy. Phlebotomies should be continued after iron depletion in order to prevent reaccumulation. These regulatory processes however do not explain how HFE gene mutations cause the increase in intestinal iron absorption since the HFE gene product is neither an iron transporter nor an iron reductase or oxidase. Only recently have carriers and regulators of cellular iron uptake and release been identified (Pietrangelo 2002, Fleming 2002, Townsend 2002, Fletcher 2002).

It has also become increasingly evident that some of them interact with the HFE gene product in the regulation of intestinal iron absorption (Pietrangelo 2002, Fleming 2002, Townsend 2002, Fletcher 2002). Recent studies have shown that the Nramp2 protein is the luminal iron carrier. Shortly thereafter, the luminal iron reductase was identified as the Dcytb protein (duodenal cytochrome B) (Pietrangelo 2002, Fleming 2002, Townsend 2002, Fletcher 2002). At the same time, the basolateral iron transporter ferroportin 1 (also named Ireg1 or MTP1) was identified (Donovan 2000, Abboud 2000) as well as the basolateral iron oxidase hepcidin (Vulpe 1999). Mutations in some of these proteins are responsible for the rarer types 2-4 of genetic hemochromatosis, although none of these genes is altered in type 1 hemochromatosis. Recently, two other proteins have been shown to act as important iron regulating proteins, transferrin receptor 2 and hepcidin (Pietrangelo 2002; Fletcher 2002; Fleming 2005). Mutations in the transferrin receptor 2 gene may lead to the rare type 3 hemochromatosis, and mutations in the ferroportin 1 gene to type 4 hemochromatosis. More recent studies also indicate that hepcidin may be the most important regulator of iron metabolism, involved in iron deficiency and overload. Hepcidin has been shown to down regulate the basolateral iron carrier ferroportin. It has also been demonstrated that hepcidin itself is up regulated by HFE. Thus, an HFE mutation may reduce the upregulation of hepcidin that then does not down regulate ferroportin; the corresponding increase in ferroportin expression finally causes the increase in intestinal iron uptake (DeDomenico 2007). There may be further interactions between HFE, transferrin receptor 2, Nramp2, Dcytb, ferroportin, hepcidin and hepcidin, all of which are currently being studied.



Figure 2. Non-genetic factors that may influence iron absorption.



**Table 2. Genotype/phenotype correlation in hemochromatosis.**

<b>Mutations/ polymorphisms</b>	<b>Prevalence in Caucasian populations</b>	<b>Risk of advanced clinical phenotype</b>
C282Y/C282Y	85-95%	low if ferritin is <1000 ng/ml
H63D/C282Y	3-8%	very low
C282Y/wild type	-	none
H63D/wild type	-	none
Others	1%	unknown

## Diagnosis

**Laboratory tests.** Any increase in serum iron should start with the exclusion of hemochromatosis so as not to overlook early disease. Normal serum iron, however, does not exclude hemochromatosis and increased serum iron often occurs in the absence of hemochromatosis. Serum iron values are highly variable and should not be used either for diagnosis or for screening of hemochromatosis. The determination of transferrin saturation is a better indicator of iron overload than serum iron. The increase in transferrin saturation usually precedes the ferritin increase (Figure 1). Transferrin saturation is more sensitive and specific for detection of hemochromatosis when compared to serum ferritin. For screening, a threshold of 50% for transferrin saturation may be optimal under fasting conditions. Ferritin on the other hand is a good indicator of largely increased iron stores and reliably indicates iron deficiency. It has less value for early detection of hemochromatosis.

In hemochromatosis a slightly increased serum ferritin (300-500 ng/ml) is usually accompanied by transferrin saturations exceeding 80-90%. Unfortunately, serum ferritin is also increased, often in the presence of infections and malignancies, and thus has a low specificity for indicating hemochromatosis (Niederau 1998). Ferritin increases not due to genetic hemochromatosis are usually associated with normal or only slightly elevated transferrin saturation. Therefore, transferrin saturation should be measured in order to correctly interpret ferritin increases.

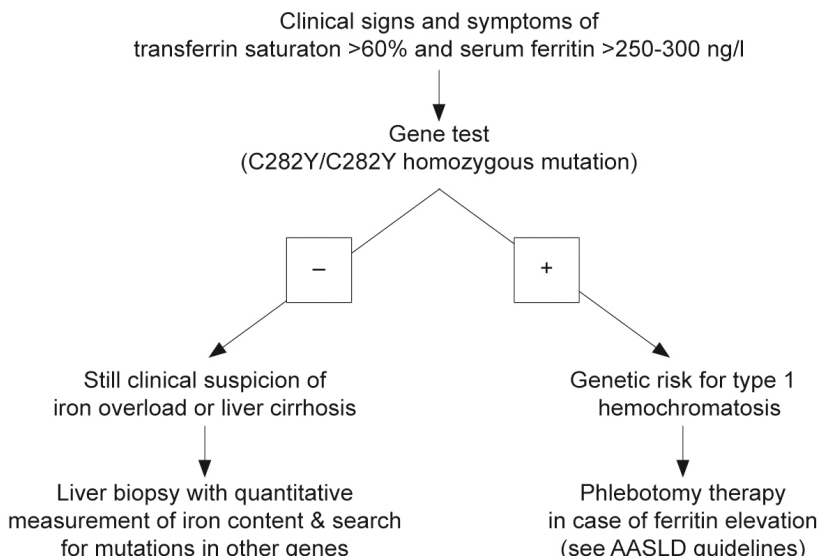
**Liver biopsy and determination of liver iron concentration.** Although simultaneous increases of both serum ferritin and transferrin saturation strongly indicate a risk for hemochromatosis, diagnosis needs to be confirmed by genetic testing or by liver biopsy with a determination of iron content in the liver. Hepatic iron concentration also increases with time in subjects with an HFE gene mutation. It is recommended to divide the liver iron concentrations by the patient's age in order to obtain the "hepatic iron index" (Summers 1990). The semi-quantitative estimation of liver iron stores by the Berlin blue colour is less sensitive and specific than the chemical quantification of liver iron concentration. In case of a homozygous C282Y gene test, liver biopsy is not required for the diagnosis of genetic hemochromatosis (Table 2).

There may, however, be other reasons to perform a liver biopsy in iron overload: (1) subjects with biochemical or clinical evidence of iron overload in the absence of the homozygous C282Y mutation should have a liver biopsy to substantiate iron overload; (2) in C282Y homozygotes the risk for liver fibrosis and cirrhosis increases at ferritin values >1000 ng/ml (Loreal 1992); in those patients liver biopsy

is recommended because the presence of liver cirrhosis markedly increases later HCC risk and thus warrants HCC screening.

**Deferoxamine testing and ferrokinetic measurements.** Determinations of urinary excretion of iron after administration of deferoxamine allows some estimation of total body iron stores. The deferoxamine test, however, often only shows pathological results when serum ferritin and transferrin saturation are markedly increased and does not allow diagnosis of early disease. Ferrokinetic measurements today are only done for scientific research or in difficult diagnostic situations.

**Computed tomography (CT), magnetic resonance tomography (MRT) and biomagnetometry.** CT density measurements of the liver allow a semi-quantitative estimation of iron concentration in the liver. This method however is associated with radiation and therefore not allowed in many countries where alternative methods are available. MRT, on the other hand, allows a reliable measurement of liver iron content, provided that special software is used and the equipment is calibrated for such measurement. In clinical practice most MRT do not fulfil these criteria. Biomagnetometry allows the most accurate non-invasive measurement of liver iron concentration. However, this equipment is expensive and only allows measurement of iron concentration. Consequently, biomagnetometry is done only at a few centres worldwide and is primarily used for scientific studies and not in daily clinical practice. With the availability of reliable and inexpensive genetic testing, CT, MRT, and biomagnetometry do not need to be done for most patients.



**Figure 3. Diagnosis and treatment algorithm for type 1 hemochromatosis.**

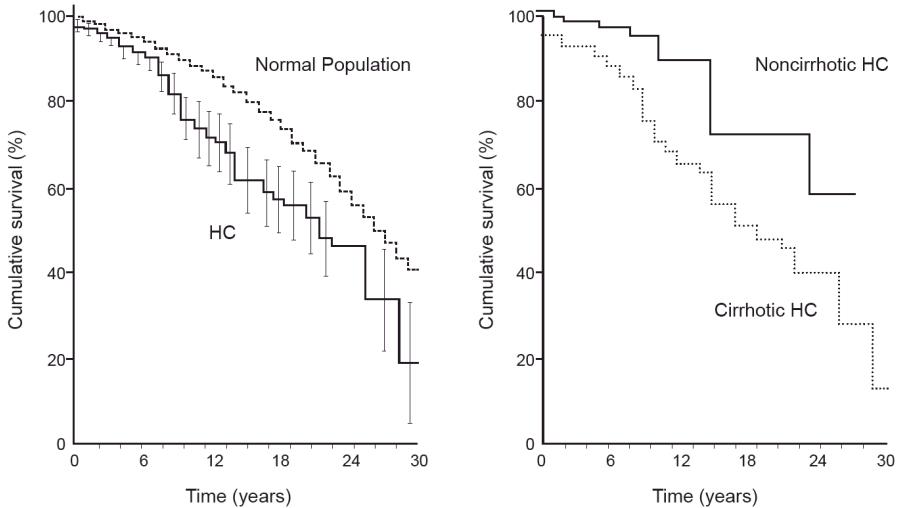
**Genetic tests.** As outlined previously, in Caucasian populations the homozygous C282Y mutation accounts for more than 90% of patients with the clinical phenotype of type 1 hemochromatosis (Adams 2005, Erhardt 1999). Approximately 5% of patients with the clinical phenotype are C282Y/H63D compound heterozygotes; the prevalence of C282Y or H63D heterozygosity in patients with the clinical

phenotype of hemochromatosis is considerably lower than in the general population. Thus, a subject who is heterozygous for C282Y or H63D per se has no risk of iron overload. In subjects homozygous for C282Y, both serum ferritin and transferrin saturation are frequently increased; however, only male subjects have an increased risk for liver disease when compared to subjects without HFE gene alterations in a recent large screening study. It is unknown how many C282Y homozygotes will later develop clinical signs and symptoms due to iron overload. It is increasingly evident that only a minority of C282Y homozygotes progress to end stage iron overload with liver cirrhosis and diabetes mellitus. In subjects who are not C282Y homozygotes but have laboratory, histological or clinical evidence of iron overload, further genes may be analysed for mutations such as hemojuveline, transferrin receptor 2, ferroportin 1 and hepcidin.

### **Early diagnosis and screening**

The prevalence of C282Y homozygotes is 0.5 % in Caucasian populations (Adams 2005, Erhardt 1999). Clinical manifestations however are variable and depend on non-genetic factors such as dietary iron intake and blood loss. Until 1980 most patients with hemochromatosis were detected with late irreversible complications such as liver cirrhosis and diabetes mellitus. With a better understanding of the disease, the broad use of ferritin and transferrin saturation measurements and the availability of a reliable genetic test, diagnostic efforts have concentrated on the detection of early disease before liver cirrhosis and diabetes mellitus. Several studies have shown that iron removal by phlebotomy is associated with normal life expectancy in patients diagnosed early (Niederau 1985, Niederau 1996, Fargion 1992) (Figure 3). Several other studies have focused on screening procedures in order to diagnose more subjects with early disease (Edwards 1988). These studies include populations with special risks, family members, as well as the general population (Table 3) (see Niederau 2002). It has been shown that an increasing number of patients are now diagnosed early and that this trend increases survival (Figure 4).

A large number of studies have shown that screening is useful for detection of asymptomatic C282Y homozygotes by using transferrin saturation and serum ferritin as well a genetic test for the C282Y mutation (Edwards 1988, Phatak 1998, Niederau 1998). A broad screening of the general population however is as yet not recommended by WHO and CDC mainly because its is unknown how many of the asymptomatic C282Y homozygotes will later develop clinical disease (see US Preventive Services Task Force 2007). The largest screening study analyzed HFE gene mutations in almost 100,000 subjects in North America. In Caucasians, C282Y homozygosity was found in 0.44%, a value similar to many previous studies in other populations with a similar background. Asian or Black people in contrast almost never have an HFE gene mutation (Adams 2005). Among the Caucasian C282Y homozygotes only males had a significant increase in liver disease when compared to subjects without an HFE gene variation (Adams 2005). Only further prospective follow-up studies will determine how many asymptomatic C282Y homozygotes will develop clinical consequences of iron overload.



**Figure 4. Survival of 251 patients with genetic hemochromatosis (with and without cirrhosis) in comparison with matched general population.** Modified from Niederau 1996.

**Table 3. Methods for early diagnosis of hemochromatosis.**

#### 1. Screening in the general population not recommended

Screening of HFE gene alterations is not recommended in the general population because it remains unknown how many of the C282Y homozygotes will develop clinical manifestations. Such screening would be meaningful only in Caucasian populations.

#### 2. Family screening

Genetic testing can reliably determine who, among the first-degree relatives of a hemochromatotic patient, is a heterozygote or homozygote. Heterozygotes are healthy and do not need follow-up. C282Y homozygotes should be followed and treated by phlebotomy if ferritin increases  $>300$  ng/ml in men and  $>200$  ng/ml in women.

#### 3. Hemochromatosis should be excluded in patients with

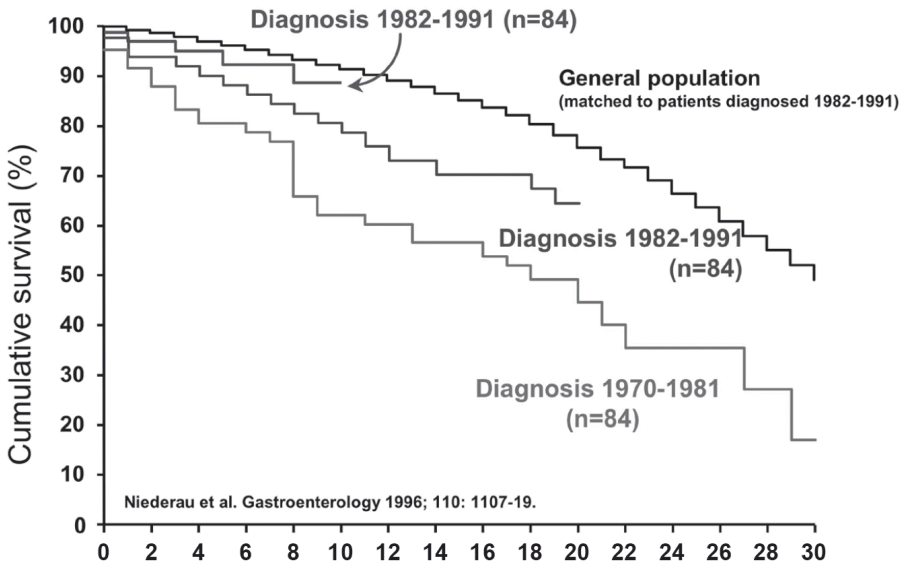
- newly diagnosed diabetes mellitus
- chronic liver disease of unknown etiology
- elevation of iron, transferrin saturation or serum ferritin
- cardiomyopathy of unknown etiology
- arthropathy of unknown etiology
- loss of potency/libido and amenorrhea of unknown etiology

#### 4. Every liver biopsy needs to be checked for iron deposits

It is also unknown at which ferritin values phlebotomy treatment should be initiated in asymptomatic C282Y homozygotes (Table 4). The values recommended by the AASLD (American Association for the Study of Liver Diseases) are based more on the judgment of experts than on solid data. The only solid data shows that the risk for liver fibrosis and cirrhosis increases above the threshold of 1000 ng/ml

for serum ferritin (Loreal 1996). The value of screening family members is obvious when a first-degree relative has clinical hemochromatosis. Such family screening is easy to do with the genetic test. Heterozygous family members are not at risk for hemochromatosis unless they have other risk factors.

The clinical phenotype of hemochromatosis is seen in 1-2% of patients with newly diagnosed diabetes mellitus and in 3-15% of patients with liver cirrhosis (Niederau 1999). These latter patients should be screened for iron overload although such screening obviously does not aim at a very early diagnosis. Nevertheless, cirrhotic and diabetic patients with hemochromatosis can benefit significantly from phlebotomy therapy. Little is known about the prevalence of hemochromatosis in patients with arthropathy or cardiomyopathy of unclear etiology. Several smaller studies indicate that arthropathy may be a rather early clinical sign of iron overload, whereas cardiomyopathy usually occurs in severe iron overload.



**Figure 5. Cumulative survival in 251 patients with genetic hemochromatosis according to the time of diagnosis.** Modified from Niederau 1996.

**Table 4. Iron overload therapy.****1. Phlebotomy****a) In symptomatic genetic hemochromatosis**

- Aims: complete iron depletion in 12-24 months;
- Treatment: 1-2 phlebotomies of 500 ml each week until serum ferritin is in the range of 20-50 ng/ml;  
long-term therapy with 4-8 phlebotomies per year to keep ferritin between 20-50 ng/ml and thus prevent reaccumulation of iron

**b) In asymptomatic C828Y homozygotes therapy should be initiated above these ferritin values:**

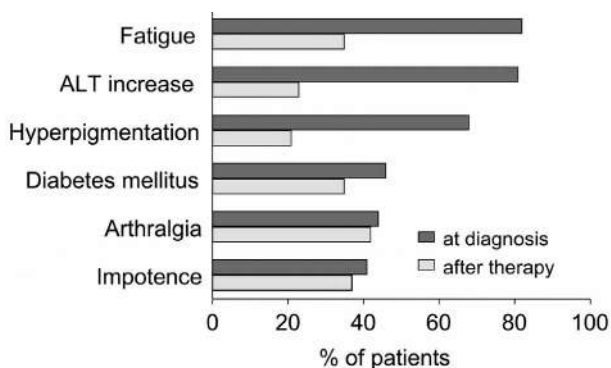
- Subjects <18 years >200 ng/ml
- Men >300 ng/ml
- Women (not pregnant) >200 ng/ml
- Women (pregnant) >500 ng/ml

**2. Therapy with iron chelators in secondary hemochromatosis and anemia**

- Aims: removal of iron overload by increase of iron excretion in feces and urine
- In case of further blood transfusions at high frequency at stabilisation of iron balance and reduction of further iron accumulation
- Treatment: until recently, 25-50 mg deferoxamine/kg as SC infusion for 10-12 h daily; today, deferoxamine is largely replaced by the oral chelator deferasirox - 20 mg/kg deferasirox once daily to prevent iron accumulation up to 800 ml erythrocytes concentrates/month
- Long-term treatment necessary
- Normalisation of ferritin and liver iron concentration is often not possible

**3. Diet**

- Recommended: avoidance of food with very high iron content (e.g., liver) and iron-supplemented food;
- A further strict iron-depleted diet is very difficult to adhere to and not recommended
- A single phlebotomy of 500 ml blood is as effective for iron removal as a very rigid iron-restricted diet for a full year



**Figure 6. Signs and symptoms in 185 patients with genetic hemochromatosis prior to and after iron removal.** Modified from Niederau 1996.

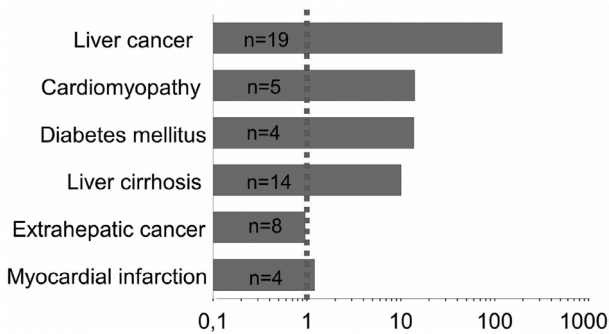
## Complications of iron overload

Liver cirrhosis, diabetes mellitus, and increased skin pigmentation are the classical trio of genetic hemochromatosis. Cardiomyopathy, cardiac arrhythmias, and impotence are also typical complications of advanced iron overload. Arthropathy in contrast may be an early sign of hemochromatosis, which may help with diagnosis in the precirrhotic stage (Niederau 1996).

**Liver disease.** The liver is the organ that is affected by genetic iron overload most early and heavily. At early stages excess iron stores are mainly found in periportal parenchymal cells as ferritin and hemosiderin. When iron excess further increases, there is development of perilobular fibrosis and iron stores are also found in bile ducts and Kupffer cells. Septal fibrosis eventually progresses towards complete cirrhosis. The stage of fibrosis is closely associated with the degree of excess of iron. In many affected symptomatic patients with type 1 hemochromatosis there are some signs of liver disease at the time of diagnosis (Niederau 1985, Niederau 1996). Many nonspecific symptoms such as abdominal discomfort and fatigue may also be due to liver involvement. In asymptomatic patients diagnosed by a screening procedure, signs of liver disease are infrequent. Complications due to cirrhosis such as ascites, jaundice and portal hypertension are seen only rarely and only in cases of advanced severe iron overload (Niederau 1985, Niederau 1996). The risk for liver cirrhosis increases at ferritin values >1000 ng/ml (Loreal 1996). Similar to insulin-dependent diabetes, liver cirrhosis cannot be reversed by removal of iron (Niederau 1996). However, less advanced stages like hepatic fibrosis and abnormalities in liver enzymes and function respond well to iron removal (Niederau 1996) (Figure 5). Survival is significantly reduced in the presence of liver cirrhosis whereas patients diagnosed in the precirrhotic stage have a normal life expectancy when treated by phlebotomy (Niederau 1996) (Figure 3).

**Association of hemochromatosis with other liver diseases.** Some studies indicate that C282Y heterozygosity may aggravate the progression of concomitant liver diseases such as porphyria cutanea tarda, chronic hepatitis C, alcoholic hepatitis and non-alcoholic steatohepatitis (NASH). In these latter patients one might find slightly elevated liver iron concentrations and serum ferritin levels when they are C282Y heterozygotes (for review see Erhardt 2003). Most studies however have shown that these associations are of only minor importance in the clinical course of the disease. Phlebotomy as yet has only been proven meaningful in porphyria cutanea tarda because it can ameliorate the cutaneous manifestations.

**Liver carcinoma.** Liver carcinoma develops in approximately 30% of patients with hemochromatosis and cirrhosis independent of iron depletion (Niederau 1996). The interval between complete iron depletion and reported diagnosis of liver cancer is approximately 9 years in large cohorts in German patients (Niederau 1985 Niederau 1996). The risk of liver cancer is increased in patients with hemochromatosis 100-200-fold when compared to the general population (Figure 6). Among liver cancers there are hepatocellular carcinomas (HCC) as well as cholangiocellular carcinomas. Most liver cancers develop in patients with cirrhosis. Thus, cancer screening by ultrasound and AFP (twice a year) is only recommended for cirrhotic patients. Patients who develop liver cancer usually have the largest amount of mobilisable iron among various subgroups (Niederau 1996, Niederau 1999).



**Figure 7. Relative mortality risk of 251 patients with genetic hemochromatosis in comparison to the general population.** Modified from Niederau 1996.

**Diabetes mellitus.** In studies the prevalence of diabetes in hereditary hemochromatosis ranges from 20-50% (Niederau 1996, Adams 1991). The prevalence and stage of diabetes is related to the degree of iron deposition in the pancreas. Patients with diabetes have a twofold higher mobilisable iron content than non-diabetics (Yaouanq 1995). Investigations into the prevalence of unrecognized genetic hemochromatosis in diabetic patients show some variation in Europe vs. elsewhere; i.e., screening revealed a prevalence of 5-8 per 1000 unrecognized cases in Europe (Singh 1992) and 9.6 per 1000 in Australia (Phelps 1989). Diabetes mellitus and impaired glucose tolerance are frequent features in several chronic liver diseases (Creutzfeldt 1970, Blei 1982). This author's study (Niederau 1984) showed hyperinsulinemia and hence insulin resistance without impaired glucose tolerance in noncirrhotic hemochromatosis. The increase in circulating insulin concentrations is likely to be due to a decrease in diminished hepatic extraction of insulin. With the progression of iron overload and destruction of beta cells, insulin secretion becomes impaired (Dymock 1972, Bierens de Haan 1973). In end-stage hemochromatosis, insulin deficiency is associated with severe reduction in the mass of beta cells (Rahier 1987). Insulin resistance observed in early iron overload may be partially reversible after phlebotomy therapy (Niederau 1985, Niederau 1996) whereas insulin-dependent diabetes is irreversible (Niederau 1996). Survival is significantly reduced in patients with diabetes mellitus at diagnosis compared to patients without diabetes (Niederau 1996). Survival of non-diabetic patients is virtually identical to that of a matched normal population.

**Heart disease.** Cardiomyopathy and cardiac arrhythmias are specific complications of hemochromatosis caused by iron deposition in the heart (Buja and Roberts 1971, Short 1981). Clinical or electrocardiographic signs of heart disease can be found in 20-35% of patients with HFE hemochromatosis (Niederau 1985). Arrhythmias usually respond well to iron removal (Short 1981, Niederau 1996). In type 1 hemochromatosis cardiomyopathy is rare and usually associated with advanced iron overload and an older patient population. However, particularly in young patients who present with cardiac disease due to hemochromatosis, cardiomyopathy is a frequent cause of death (Finch 1966, Short 1981). Only



recently has it become clear that young patients with severe cardiomyopathy may be affected by juvenile type 2 hemochromatosis; these patients may show severe iron overload, hypogonadism, cardiomyopathy, liver cirrhosis, and amenorrhea by ages 15-24. The type 2-associated cardiomyopathy is often irreversible despite initiation of phlebotomy or chelation therapy and may require an immediate transplant of the heart and potentially of the liver as well (von Herbay 1996, Jensen 1993).

**Arthropathy.** Joint changes in genetic hemochromatosis may occur in two different ways (Schuhmacher 1964, Dymock 1970, Niederau 1985, Niederau 1996). The most prevalent changes are seen in the metacarpophalangeal joints II and III, in the form of cystic and sclerotic changes, cartilage damage and a narrowing of the intraarticular space. Sometimes other joints of the hands and the feet are affected. Large joints, i.e., of the knees and hips, may be affected in the form of chondrocalcinosis. The pathogenesis of joint changes in hemochromatosis remains unclear. Arthropathy is one of the few complications not associated with the degree of iron overload. It has been speculated that iron may inhibit pyrophosphatase and may thereby lead to a crystallisation of calcium pyrophosphates. Alternatively, iron may have direct toxic effects on the joints. Arthropathy may be an early sign of hemochromatosis and may help to make the diagnosis at a precirrhotic stage (Niederau 1996). Hemochromatosis should therefore be considered in all patients with an arthropathy of unknown etiology.

**Endocrine abnormalities.** In contrast to the early onset of arthropathic changes, endocrine abnormalities are a late consequence of iron overload. Sexual impotence and loss of libido may occur in up to 40% of male patients (Niederau 1985). The endocrine abnormalities in hemochromatosis are mainly, if not exclusively, due to pituitary failure. This is in contrast to alcoholic cirrhosis where testicular failure is predominant (Kley 1985a, Kley 1985b). In contrast to alcoholic cirrhosis, where estrogen levels are usually increased, estrogen levels were found decreased in hemochromatosis (Kley 1985a). Most endocrine changes are late and irreversible complications of genetic hemochromatosis and do not respond well to phlebotomy treatment (Niederau 1996). Iron overload only infrequently affects other endocrine organs such as the thyroid and adrenal glands. Severe hypogonadism with amenorrhea in young women and impotence in young men is today thought to be due to type 2 hemochromatosis.

**Skin.** Increased skin pigmentation is mainly seen in areas exposed to sunlight. A large part of the darkening of pigmentation is thought to be due to an increase in melanin and not due to iron excess itself. The increase in skin pigmentation is reversible on iron removal (i.e., phlebotomy).

**Other potential complications.** Iron overload has been speculated to aggravate atherosclerosis; however, the evidence for that is rather weak (for review see Niederau 2000). There have also been reports that extrahepatic malignancies may be increased in HFE hemochromatosis (Amman 1980, Fracanzani 2001) while other studies have not found extrahepatic associations (Bain 1984, Niederau 1996, ElMBERG 2003). It is not clear whether HFE gene mutations are involved in the pathogenesis of porphyria cutanea tarda since the prevalence of both risk factors vary greatly in different parts of the world; associations between HFE gene mutations and porphyria have often been described in southern Europe but not in northern Europe (Toll 2006).

## Therapy

**Phlebotomy treatment.** Phlebotomy treatment is the standard of care to remove iron in genetic hemochromatosis. One phlebotomy session removes approximately 250 mg iron from the body. Since patients with the classical clinical phenotype may have an excess of 10-30 g iron, it may take 12-24 months to remove the iron overload when phlebotomies of 500 ml blood are done weekly (Table 4). Phlebotomy treatment is generally well tolerated and hemoglobin usually does not drop below 12 g/dl. Several studies have shown that liver iron is completely removed at such low ferritin values; thus the effect of therapy can be checked by ferritin measurements and a control liver biopsy is not necessary. After complete removal of excess iron the intervals of phlebotomies may be increased to once every 2-3 months; serum ferritin should be kept in the lower normal range, between 20-50 ng/ml. Phlebotomy should not be interrupted for longer intervals; there is a risk of reaccumulation of iron due to the genetic autosomal recessive metabolic malfunction.

**Iron removal by chelators.** Deferoxamine therapy for genetic hemochromatosis is not recommended because phlebotomy is more effective with less side effects and lower cost. Recently, a Phase II study has started, looking for safety and effectiveness of the new oral iron chelator deferasirox in genetic hemochromatosis. As yet, deferasirox is only approved for secondary hemochromatosis.

**Diet.** An iron-low diet is not recommended for patients with genetic hemochromatosis. One phlebotomy of 500 ml blood removes approximately 250 mg iron. A difficult to follow rigid iron-restricted diet for a complete year would have the effect of a single phlebotomy. It is thus recommended that patients simply do not eat excessive amounts of food with very high iron content (such as liver) and that they do not eat food to which iron has been added (Table 4).

**Liver transplantation.** Advanced liver cirrhosis and carcinoma may be indications for a liver transplant in hemochromatosis (Kowdley 1995, Brandhagen 2000). The prognosis of patients who have a liver transplant for hemochromatosis is markedly worse than that for patients with other liver diseases; a considerable number of patients with hemochromatosis die after transplant from infectious complications or heart failure (Brandhagen 2000). Liver transplantation does not heal the original genetic defect.

## Prognosis

Untreated hemochromatosis often has a bad prognosis in the presence of liver cirrhosis and diabetes mellitus. The prognosis is markedly worse in patients with cirrhosis than in those without cirrhosis at diagnosis (Figure 3); the same is true for diabetes mellitus. It is generally accepted that phlebotomy therapy improves the prognosis. Patients diagnosed and treated in the early non-cirrhotic stage have a normal life expectancy (Figure 3) (Niederau 1985, Niederau 1996). Thus, early diagnosis markedly improves the prognosis (Figure 4). Iron removal by phlebotomy also improves the outcome in patients with liver cirrhosis. The prognosis of liver cirrhosis due to hemochromatosis is markedly better than those with other types of cirrhosis (Powell 1971). Hepatomegaly and elevation of aminotransferases often regress after iron removal (Niederau 1985, Niederau 1996) (Figure 5). Insulin-dependent diabetes mellitus and hypogonadism are irreversible complications despite complete iron removal (Niederau 1996) (Figure 5). Earlier changes in glucose and

insulin metabolism, however, may be ameliorated after iron removal. For unknown reasons arthropathy does not respond well to phlebotomy treatment although it may be an early sign of iron overload (Figure 5). The AASLD consensus guidelines recommend to start phlebotomy treatment at ferritin values >300 ng/ml in men and >200 ng/ml in women. The risk for liver fibrosis and cirrhosis is increased only at ferritin levels >1000 ng/ml. Further studies need to determine whether asymptomatic C282Y homozygotes with ferritin values between 300 and 1000 ng/ml need to be treated or whether one might wait and monitor ferritin at that stage.

### **Juvenile hereditary hemochromatosis**

Two genes have been shown to be associated with juvenile hemochromatosis: 90% of cases are associated with mutations in hemojuveline (HJV) (locus name HFE2A, which encodes HJV), while 10% of cases are associated with HAMP (locus name HFE2B, which encodes hepcidin). Despite the nomenclature of HFE2A and HFE2B, juvenile hemochromatosis is not associated with HFE mutations. In order to avoid confusion most physicians use the terms type 2A (hemojuvelin mutations) and type 2B (HAMP mutations). Mutations in hemojuvelin are associated with low levels of hepcidin in urine suggesting that hemojuvelin regulates hepcidin. Hepcidin is the key regulator of intestinal iron absorption and iron release from macrophages. Hepcidin facilitates ferroportin internalisation and degradation. Hepcidin mutations may thereby lead to an increase in ferroportin and thus iron uptake from the intestine. Juvenile hemochromatosis is very rare. A clustering of HJV mutations is seen in Italy and Greece although few families account for this phenomenon. Mutations in HJV represent the majority of worldwide cases of juvenile hemochromatosis.

Only a small number of patients have been identified with HAMP-related juvenile hemochromatosis. Juvenile hemochromatosis is characterized by an onset of severe iron overload in the first to third decades of life. Clinical features include hypogonadism, cardiomyopathy, and liver cirrhosis (Diamond 1989, Vaiopoulos 2003). The main cause of death is cardiomyopathy (De Gobbi 2002, Filali 2004). In contrast to HFE type 1 hemochromatosis, both sexes are equally affected. Mortality can be reduced in juvenile hemochromatosis when it is diagnosed early and treated properly. Phlebotomy is the standard therapy in juvenile hemochromatosis as well and is treated similarly to HFE hemochromatosis (Tavill 2001). In patients with juvenile hemochromatosis and anemia or severe cardiac failure, administration of chelators such as deferoxamine have been tried to reduce mortality; some case reports suggest that this might improve left ventricular ejection fraction (Kelly 1998).

### **Transferrin receptor 2 (TFR2)-related type 3 hemochromatosis**

TFR2-related hemochromatosis is defined as type 3 and is also known as HFE3; however, the term HFE3 should not be used because the HFE gene is not affected in type 3 hemochromatosis. TFR2-related hemochromatosis is inherited in an autosomal recessive manner. TFR2 is a type II 801-amino acid transmembrane glycoprotein expressed in hepatocytes and at lower levels in Kupffer cells (Zhang 2004). A finely regulated interaction between TFR2, TFR1 and HFE is now thought

to affect the hepcidin pathway, and, consequently, iron homeostasis (Fleming 2005). Patients with homozygous TFR2 mutations have increased intestinal iron absorption that leads to iron overload. Hepcidin concentrations in urine are low in TFR2 hemochromatosis (Nemeth 2005). TFR2-related hemochromatosis is very rare with only about 20 patients reported worldwide (Mattman 2002). Age of onset in TFR2-related type 3 hemochromatosis is earlier than in HFE-associated type 1 (Piperno 2004, Girelli 2002, Hattori 2003). Progression is, however, slower than in juvenile type 2 (De Gobbi 2002, Roetto 2001, Girelli 2002). The phenotype is similar to type 1. Many patients present with fatigue, arthralgia, abdominal pain, decreased libido, or with biochemical signs of iron overload (Roetto 2001, Girelli 2002, Hattori 2003). Complications of type 3 hemochromatosis include cirrhosis, hypogonadism, and arthropathy. Cardiomyopathy and diabetes mellitus appear to be rather rare. Hepatocellular carcinoma has not been observed in the small number of cases diagnosed. Most individuals with type 3 hemochromatosis have an Italian or Japanese genetic background. Some of the Japanese males have had liver cirrhosis at diagnosis (Hattori 2003). Similar to type 1 hemochromatosis, the penetration of type 3 hemochromatosis is also considerably less than 100% (Roetto 2001). Standard therapy is iron removal by weekly phlebotomy similar to the management of type 1 disease. Individuals with increased ferritin should be treated similar to those with HFE hemochromatosis.

### **Type 4 hemochromatosis – Ferroportin Disease**

Ferroportin-associated iron overload (also called Ferroportin Disease) was first recognised by Pietrangelo (1999) who described an Italian family with an autosomal dominant non-HFE hemochromatosis. Many family members had iron overload resulting in liver fibrosis, diabetes, impotence, and cardiac arrhythmias. In addition to autosomal dominant inheritance, features distinguishing this from HFE hemochromatosis included early iron accumulation in reticuloendothelial cells and a marked increase in ferritin earlier than what is seen in transferrin saturation (Pietrangelo 1999, Rivard 2003, Montosi 2001, Wallace 2004, Fleming 2001). Several patients showed a reduced tolerance to phlebotomy and became anemic despite elevated ferritin (Pietrangelo 1999, Jouanolle 2003).

In 2001 this form of non-HFE hemochromatosis was linked to mutations of ferroportin (Montosi 2001) that had just been identified as the basolateral iron transporter (Abboud 2000, Donovan 2000). Since that time, numerous mutations in the gene have been implicated in patients from diverse ethnic origins with previously unexplained hemochromatosis. Iron overload disease due to ferroportin mutations has been defined as type 4 hemochromatosis or Ferroportin Disease (for review see Pietrangelo 2004). The iron export is tightly regulated because both iron deficiency and iron excess are harmful. The main regulator of this mechanism is the peptide hepcidin which binds to ferroportin, induces its internalization and degradation, thereby reducing iron efflux (Nemeth 2004). Increase in iron absorption may be caused either by hepcidin deficiency or its ineffective interaction with ferroportin. All recent studies have shown that hepcidin deficiency appears to be the common characteristic of most types of genetic hemochromatosis (mutations in HFE, transferrin receptor 2, hemojuvelin, or hepcidin itself). The remaining cases of genetic iron overload are due to heterozygous mutations in the hepcidin target, ferroportin. Because of the mild clinical penetrance of the genetic defect there were

doubts about the rationale for iron removal therapy. However, a recent study shows that there may be clinically relevant iron overload with organ damage and liver cancer in patients carrying the A77D mutation of ferroportin (Corradini 2007). Treatment schemes are similar to those described for other types of genetic hemochromatosis.

## Secondary hemochromatosis

### Pathophysiology

Most forms of secondary hemochromatosis are due to hemolytic anemia associated with polytransfusions such as thalassemia, sickle cell disease, and MDS. Most of these patients need blood transfusions on a regular basis for survival. However, in the long run, multiple blood transfusions often lead to iron overload if patients are not treated with iron chelators. In general, iron overload due to blood transfusions is similar to genetic hemochromatosis; however, secondary iron overload develops much faster than the genetic forms (McLaren 1983), sometimes as soon as after 10-12 blood transfusions (Porter 2001). Subsequently secondary iron overload can result in more rapid organ damage when compared with genetic hemochromatosis. Secondary iron overload can obviously not be treated by phlebotomy because a marked anemia is the clinical marker of the disease. Secondary iron overload often limits the prognosis of patients with thalassemia; life expectancy deteriorates with increasing iron concentrations in the liver (Telfer 2000). Therapy with iron chelator may reduce the transfusional iron burden if the frequency of transfusion is not too high. The development of HFE versus secondary hemochromatosis not only differs in terms of the speed of iron accumulation but also in the type of organ damage; in secondary hemochromatosis cardiomyopathy is often the complication that limits the prognosis (Liu 1994). It is interesting that heart disease is also very frequent in juvenile genetic hemochromatosis where there is also rapid iron accumulation. In general, serum ferritin values closely reflect liver iron concentration and may be used as an indication for timing of therapy as well as to check the effects of iron chelation.

Until recently deferoxamine was the only iron chelator available in most countries; in some countries the drug deferiprone is approved for patients who do not tolerate deferoxamine (Hoffbrandt 2003). The clinical use of deferiprone was limited due to side effects such as agranulocytosis and neutropenia (Refaie 1995). Long-term data prove that deferoxamine can reduce iron overload and its organ complications (Olivieri 1994, Cohen 1981). Deferoxamine, however, needs to be given daily subcutaneously or by IV infusion for several hours. Thus, patients with thalassemia often consider the deferoxamine treatment worse than thalassemia itself (Goldbeck 2000). There are minor compliance problems that often limit the beneficial effects of this iron chelator (Cohen 1989).

Without iron chelation, children with thalassemia often develop a severe cardiomyopathy prior to age 15 (Cohen 1987). After that age, liver cirrhosis is also a significant complication in secondary iron overload due to thalassemia (Zurlo 1992). Iron chelation should start early to prevent complications of iron overload. By the ages of 3-5, liver iron concentration may reach values associated with a significant risk for liver fibrosis in severe thalassemia (Angelucci 1995). Children younger than 5 should therefore be cautiously treated with chelators if they have

received transfusions for more than a year (Olivieri 1997). Deferoxamine can reduce the incidence and ameliorate the course of iron-associated cardiomyopathy (Olivieri 1994, Brittenham 1994, Miskin 2003).

Deferasirox is an oral iron chelator with high selectivity for iron III (Nick 2003). Deferasirox binds iron in a 2:1 proportion with a high affinity and increases the biliary iron excretion (Nick 2003). This chelator is able to reduce iron overload in hepatocytes and cardiomyocytes (Nick 2003, Hershko 2001). Due to its half-life of 11-18 hours it needs to be taken only once daily (Nisbet-Brown 2003). Deferasirox exerted a similar iron chelation when compared with deferoxamine in patients with thalassemia; the effect of 40 mg/kg deferoxamine was similar to that of 20 mg/kg deferasirox (Piga 2006). Both in adults and children 20-30 mg/kg/day deferasirox significantly reduced liver iron concentration and serum ferritin (Cappellini 2006). Magnetic resonance imaging showed that 10-30 mg/day deferasirox may also reduce iron concentration in the heart within one year of maintenance therapy. Deferasirox may cause minor increases in serum creatinine as well as gastrointestinal discomfort and skin exanthema which are usually self-limiting. Considering the compliance problems with deferoxamine, deferasirox has a better cost-effectiveness ratio (Vichinsky 2005). Deferasirox is defined as standard therapy both in the guidelines of the National Comprehensive Cancer Network (NCCN) (USA) and in the international guidelines on MDS (Greenberg 2006, Gattermann 2005).

## References

- Abboud S, Haile DJ. A novel mammalian iron-regulated protein involved in intracellular iron metabolism. *J Biol Chem* 2000;275:19906-12. ([Abstract](#))
- Adams PC, Speechley M, Kertesz AE. Long-term survival analysis in hereditary hemochromatosis. *Gastroenterology* 1991;101:368-72. ([Abstract](#))
- Adams PC, Reboussin DM, Barton JC, et al. Hemochromatosis and iron-overload screening in a racially diverse population. *N Engl J Med* 2005; 352:1769-78. ([Abstract](#))
- Angelucci E, Baronciani D, Lucarelli G, et al. Needle liver biopsy in thalassaemia: analyses of diagnostic accuracy and safety in 1184 consecutive biopsies. *Br J Haematol* 1995;89:757-61. ([Abstract](#))
- Bain C, Bradbear R, Siskind V, et al. Cohort study of the risk of malignancy in haemochromatosis and other nonalcoholic liver diseases. *Hepatology* 1984;4:A1020. ([Abstract](#))
- Biasiotto G, Belloli S, Ruggeri G, et al. Identification of new mutations of the HFE, hepcidin, and transferrin receptor 2 genes by denaturing HPLC analysis of individuals with biochemical indications of iron overload. *Clin Chem* 2003;49:1981-8. ([Abstract](#))
- Bierens deHaan B, Scherrer JR, Stauffacher W, et al. Iron excess, early glucose intolerance, and impaired insulin secretion in idiopathic hemochromatosis. *Eur J Clin Invest* 1973;3:179-87. ([Abstract](#))
- Blei AT, Robbins DC, Drobny E, et al. Insulin resistance and insulin receptors in hepatic cirrhosis. *Gastroenterology* 1982;83:1313-8. ([Abstract](#))
- Brandhagen DJ, Alvarez W, Therneau TM, et al. Iron overload in cirrhosis-HFE genotypes and outcome after liver transplantation. *Hepatology* 2000;31:456-60. ([Abstract](#))
- Brittenham GM, Griffith PM, Nienhuis AW, et al. Efficacy of deferoxamine in preventing complications of iron overload in patients with thalassemia major. *N Engl J Med* 1994;331:567-73. ([Abstract](#))
- Buja L, Roberts W. C Iron in the heart. *Am J Med* 1971;51:209-221. ([Abstract](#))
- Cappellini MD, Cohen A, Piga A, et al. A Phase III study of deferasirox (ICL670), a once-daily oral iron chelator, in patients with beta-thalassemia. *Blood* 2006;107:3455-62. ([Abstract](#))
- Cohen A, Martin M, Schwartz E. Response to long-term deferoxamine therapy in thalassemia. *J Pediatr* 1981;99:689-694. ([Abstract](#))

- Cohen AR, Mizanin J, Schwartz E. Rapid removal of excessive iron with daily, high-dose intravenous chelation therapy. *J Pediatr* 1989;115:151-5. ([Abstract](#))
- Cohen A. Management of iron overload in the pediatric patient. *Hematol Oncol Clin North Am* 1987;1:521-44. ([Abstract](#))
- Corradini E, Ferrara F, Pollicino T, et al. Disease progression and liver cancer in the ferroportin disease. *Gut* 2007;56:1030-2. ([Abstract](#))
- Creutzfeldt W, Frerichs H, Sickinger K. Liver diseases and diabetes mellitus. *Prog Liver Dis* 1970;3:371-407. ([Abstract](#))
- Crosby WH. Hereditary hemochromatosis. In: Ingelfinger FJ (ed) *Controversy in internal medicine*. Saunders, Philadelphia, 1966:261-70.
- De Domenico I, Diane M, Ward DM, et al. Hepcidin regulation: ironing out the details. *J Clin Invest* 2007;117:1755-8. ([Abstract](#))
- De Gobbi M, Pasquero P, Brunello F, et al. Juvenile hemochromatosis associated with B-thalassemia treated by phlebotomy and recombinant human erythropoietin. *Haematologica* 2000;85:865-7. ([Abstract](#))
- Diamond T, Stiel D, Posen S. Osteoporosis in hemochromatosis: iron excess, gonadal deficiency, or other factors? *Ann Intern Med* 1989;110:430-6. ([Abstract](#))
- Donovan A, Brownlie A, Zhou Y, et al. Positional cloning of zebrafish ferroportin1 identifies a conserved vertebrate iron exporter. *Nature* 2000;403:778-81. ([Abstract](#))
- Dymock W, Hamilton EBD, Laws JW, et al. Arthropathy of hemochromatosis: clinical and radiological analysis of 73 patients with iron overload. *Ann Rheum Dis* 1970;29:469-76. ([Abstract](#))
- Dymock W, Cassar J, Pyke DA, et al. Observations on the pathogenesis, complications, and treatment of diabetes in 115 cases of hemochromatosis. *Am J Med* 1972;52:203-10. ([Abstract](#))
- Edwards CQ, Griffen LM, Goldgar D, et al. Prevalence of hemochromatosis among 11,065 presumably healthy blood donors. *N Engl J Med* 1988;318:1355-62. ([Abstract](#))
- Elmberg M, Hultcrantz R, Ekborn A, et al. Cancer risk in patients with hereditary hemochromatosis and in their first-degree relatives. *Gastroenterology* 2003;125:1733-41. ([Abstract](#))
- Erhardt A, Niederau C, Osman Y, et al. Demonstration of HFE polymorphism in German patients with hereditary hemochromatosis. *Dtsch Med Wochenschr* 1999;124:1448-52. ([Abstract](#))
- Erhardt A, Maschner-Olberg A, Mellenthin C, et al. HFE mutations and chronic hepatitis C: H63D and C282Y heterozygosity are independent risk factors for liver fibrosis and cirrhosis. *J Hepatol* 2003;38:335-42. ([Abstract](#))
- Fargion S, Mandelli C, Piperno A, et al. Survival and prognostic factors in 212 Italian patients with genetic hemochromatosis. *Hepatology* 1992;15:655-9. ([Abstract](#))
- Feder JN, Gnirke A, Thomas W, et al. A novel MCH class I-like gene is mutated in patients with hereditary haemochromatosis. *Nature Genetics* 1996;13:399-407. ([Abstract](#))
- Filali M, Le Jeune C, Durand E, et al. Juvenile hemochromatosis HJV-related revealed by cardiogenic shock. *Blood Cells Mol Dis* 2004;33:120-4. ([Abstract](#))
- Finch SC, Finch CA. Idiopathic hemochromatosis, an iron storage disease. *Medicine* 1966;34:381-430. ([Abstract](#))
- Fleming RE, Sly WS. Ferroportin mutation in autosomal dominant hemochromatosis: loss of function, gain in understanding. *J Clin Invest* 2001;108:521-2. ([Abstract](#))
- Fleming RE, Sly WS. Mechanisms of iron accumulation in hereditary hemochromatosis. *Ann Rev Physiol* 2002;4:663-80. ([Abstract](#))
- Fletcher LM, Halliday JW. Haemochromatosis: Understanding the mechanism of disease and implications for diagnosis and patient management following the recent cloning of novel genes involved in iron metabolism. *J Intern Med* 2002;251:181-92. ([Abstract](#))
- Gattermann N. Consensus statement on iron overload in myelodysplastic syndromes. *Hematol Oncol Clin N Am* 2005;19:S18-S25.
- Girelli D, Bozzini C, Roetto A. Clinical and pathological finding in hemochromatosis type 3 due to a novel mutation in transferrin receptor 2 gene. *Gastroenterology* 2002;122:1295-1302. ([Abstract](#))
- Goldbeck L, Baving A, Kohn E. Psychosocial aspects of beta-thalassemia: distress, coping and adherence. *Klin Pädiatr* 2000;212:254-59. ([Abstract](#))
- Greenberg PL, Baer MR, Bennett JM, et al. Myelodysplastic syndromes clinical practice guidelines in oncology. *J Natl Compr Canc Netw* 2006;4:58-77. ([Abstract](#))

- Hanot V, Schachmann M. Sur la cirrhose pigmentaire dans le diabete. sucre. Arch Physiol Norm Pathol 1886;7:50-72.
- Hattori A, Wakusawa S, Hayashi H, et al. AVAQ 594-597 deletion of the TfR2 gene in a Japanese family with hemochromatosis. Hepatol Res 2003;26:154-6. (Abstract)
- Herbay von A, Niederau C, Pelichowska M, et al. Kardiomyopathie als Todesursache bei genetischer Hämochromatose. Z Gastroenterol 1996;34:178-82. (Abstract)
- Hershko C, Konijn AM, Nick HP, et al. ICL670A: a new synthetic iron chelator: evaluation in hypertransfused rats with selective radio iron probes of hepatocellular and reticuloendothelial iron stores and in ironloaded rat heart cells in culture. Blood 2001;97:1115-22. (Abstract)
- Jensen PD, Bagger JP, Jensen FT, et al. Heart transplantation in a case of juvenile hereditary haemochromatosis followed up by MRI and endomyocardial biopsies. Eur J Haematol 1993;51:199-205. (Abstract)
- Jouanolle AM, Douabin-Gicquel V, Halimi C, et al. Novel mutation in ferroportin 1 gene is associated with autosomal dominant iron overload. J Hepatol 2003;39:286-9. (Abstract)
- Kelly AL, Rhodes DA, Roland JM, et al. Hereditary juvenile haemochromatosis: a genetically heterogeneous life-threatening iron-storage disease. QJM 1998;91:607-18. (Abstract)
- Kley HK, Stremmel W, Niederau C, et al. Androgen and estrogen response to adrenal and gonadal stimulation in idiopathic hemochromatosis: evidence for decreased estrogen formation Hepatology 1985a;251-6. (Abstract)
- Kley HK, Niederau C, Stremmel W, et al. Conversion of androgens to estrogens in idiopathic hemochromatosis: comparison with alcoholic cirrhosis. J Clin Endocrinol Metabol 1985b;61:1-6. (Abstract)
- Kowdley K, Hassanein T, Kaur S, et al. Primary liver cancer and survival in patients undergoing liver transplantation for hemochromatosis. Liver Transpl Surg 1995;1:237-41. (Abstract)
- Liu P, Olivieri N. Iron overload cardiomyopathies: new insights into an old disease. Cardiovasc Drugs Ther 1994;8:101-10. (Abstract)
- Loreal O, Deugnier Y, Moirand R. Liver fibrosis in genetic hemochromatosis. Respective roles of iron and non-iron related factors in 127 homozygous patients. J Hepatol 1992;16:122-7. (Abstract)
- MacDonald RA, Mallory GK. Hemochromatosis and hemosiderosis. Study in 211 autopsied cases. Arch Intern Med 1960;105:686-700. (Abstract)
- Mattman A, Huntsman D, Lockitch G, et al. Transferrin receptor 2. (TfR2) and HFE mutational analysis in non-C282Y iron overload: identification of a novel TfR2 mutation. Blood 2002;100:1075-7. (Abstract)
- McLaren GD, Muir WA, Kellermeyer RW. In overload disorders: natural history, pathogenesis, diagnosis, and therapy. Crit Rev Clin Lab Sci 1983;19:205-66. (Abstract)
- Miskin H, Yaniv I, Berant M, et al. Reversal of cardiac complications in thalassemia major by long-term intermittent daily intensive iron chelation. Eur J Haematol 2003;70:398-403. (Abstract)
- Montosi G, Donovan A, Totaro A, et al. Autosomal-dominant hemochromatosis is associated with a mutation in the ferroportin (SLC11A3) gene. J Clin Invest 2001;108:619-3. (Abstract)
- Nemeth E, Tuttle MS, Powelson J, et al. Heparin regulates cellular iron efflux by binding to ferroportin and inducing its internalization. Science 2004;306:2090-3. (Abstract)
- Nemeth E, Roetto A, Garozzo G, et al. Heparin is decreased in TFR2-Hemochromatosis. Blood 2005;105:1803-6. (Abstract)
- Nick H, Acklin P, Lattmann R, et al. Development of tridentate iron chelators: from desferriethiocin to ICL670. Curr Med Chem 2003;10:1065-76. (Abstract)
- Niederau C, Berger M, Stremmel W, et al. Hyperinsulinaemia in non-cirrhotic haemochromatosis: impaired hepatic insulin degradation? Diabetologia 1084; 26:441-4. (Abstract)
- Niederau C, Fischer R, Sonnenberg A, et al. Survival and causes of death in cirrhotic and noncirrhotic patients with primary haemochromatosis. New Engl J Med 1985;313:1256-62. (Abstract)
- Niederau C, Fischer R, Pürschel A, et al. Long-term survival in patients with hereditary hemochromatosis. Gastroenterology 1996;110:1107-1119. (Abstract)
- Niederau C, Niederau CM, Littauer A, et al. Screening for iron overload and iron deficiency. Ann Int Med 1998;128:337-45. (Abstract)



- Niederer C. Diabetes mellitus bei Hämochromatose. *Z Gastroenterol* 1999;37:22-32. (Abstract)
- Niederer C. Iron overload and atherosclerosis. *Hepatology* 2000;32:672-4. (Abstract)
- Nisbet-Brown E, Olivieri F, Giardina PJ, et al. Effectiveness and safety of ICL670 in iron-loaded patients with thalassaemia: a randomised, double-blind, placebo-controlled, dose-escalation trial. *Lancet* 2003;361:1597-1602. (Abstract)
- Njajou OT, Vaessen N, Joosse M, et al. A mutation in SLC11A3 is associated with autosomal dominant hemochromatosis. *Nat Genet* 2001;28:213-4. (Abstract)
- Olivieri NF, Brittenham GM. Iron-chelating therapy and the treatment of thalassemia. *Blood* 1997;89:739-61. (Abstract)
- Olivieri NF, Nathan DG, Macmillan JH, et al. Survival in medically treated patients with homozygous beta-thalassemia. *N Engl J Med* 1994;331:574-8. (Abstract)
- Phatak PD, Sham RL, Raubertas RF, et al. Prevalence of hereditary hemochromatosis in 16,031 primary care patients. *Ann Intern Med* 1998;129:954-61. (Abstract)
- Phelps G, Chapman I, Hall P, et al. Prevalence of genetic haemochromatosis among diabetic patients. *Lancet* 1989;2:233-4. (Abstract)
- Pietrangelo A, Montosi G, Totaro A. Hereditary hemochromatosis in adults without pathogenic mutations in the hemochromatosis gene. *N Engl J Med* 1999;341:725-32. (Abstract)
- Pietrangelo A. Physiology of iron transport and the hemochromatosis gene. *Am J Physiol Gastrointest Liver Physiol* 2000;282:G403-G414. (Abstract)
- Pietrangelo A. Hereditary hemochromatosis -a new look at an old disease. *N Engl J Med* 2004;350:2383-97. (Abstract)
- Pietrangelo A. The ferroportin disease. *Blood Cells Mol Dis* 2004;32:131-8
- Piga A, Galanello R, Forni GL, et al. Randomized phase II trial of deferasirox (Exjade, ICL670), a once-daily, orally-administered iron chelator, in comparison to deferoxamine in thalassemia patients with transfusional iron overload. *Haematologica* 2006;91:873-80. (Abstract)
- Piperno A, Roetto A, Mariani R, et al. Homozygosity for transferrin receptor-2 Y250X mutation induces early iron overload. *Haematologica* 2004; 89:359-60. (Abstract)
- Porter JB Practical management of iron overload. *Br J Haematol* 2001;115:239-52. (Abstract)
- Powell LW, Mortimer R, Harris OD. Cirrhosis of the liver: A comparative study of the four major aetiological groups. *Med J Aust* 1971;58:1941-50. (Abstract)
- Rahier J, Loozen S, Goebbels RM, et al. The haemochromatosis human pancreas: a quantitative immunochemical and ultrastructural study. *Diabetologia* 1987;30:5-12. (Abstract)
- Recklinghausen von FD. Über Hämochromatose. *Berl Klin Wochenschr* 1898;26:925
- Rivard SR, Lanzara C, Grimard D, et al. Autosomal dominant reticuloendothelial iron overload (HFE type 4) due to a new missense mutation in the FERROPORTIN 1 gene (SLC11A3) in a large French-Canadian family. *Haematologica* 2003;88:824-6. (Abstract)
- Roetto A, Totaro A, Cazzola M, et al. Juvenile hemochromatosis locus maps to chromosome 1q. *Am J Hum Genet* 1999;64:1388-93. (Abstract)
- Roetto A, Totaro A, Piperno A, et al. New mutations inactivating transferrin receptor 2 in hemochromatosis type 3. *Blood* 2001;97:2555-60. (Abstract)
- Schuhmacher HR. Hemochromatosis and arthritis. *Arthr Rheum* 1964;7:41-50. (Abstract)
- Sheldo JH. Hemochromatosis. Oxford University Press, 1935, London.
- Short EM, Winkle RA, Billingham ME. Myocardial involvement in idiopathic hemochromatosis. *Am J Med* 1979;70:1275-9. (Abstract)
- Singh BM, Grunewald RA, Press M, et al. Prevalence of haemochromatosis amongst patients with diabetes mellitus. *Diabet Med* 1992 ;9:730-1. (Abstract)
- Simon M, Pawlotsky Y, Bourel M, et al. Hemochromatose idiopathique. *Maladie associee a l'antigen HLA-A3?* *Nouv Press Med* 1075;4:1432. (Abstract)
- Simon M, Bourel M, Genetet B. Idiopathic hemochromatosis: demonstration of recessive transmission and early detection by family HLA typing. *N Engl J Med* 1977;297:1017-21. (Abstract)
- Summers KM, Halliday JW, Powell LW. Identification of homozygous hemochromatosis subjects by measurement of hepatic iron index. *Hepatology* 1990;12:20-5. (Abstract)
- Tavill AS. Diagnosis and management of hemochromatosis. *Hepatology* 2001;33:1321-8. (Abstract)
- Telfer PT, Prestcott E, Holden S, et al. Hepatic iron concentration combined with long-term monitoring of serum ferritin to predict complications of iron overload in thalassaemia major. *Br J Haematol* 2000;110:971-7. (Abstract)

- Toll A, Celis R, Ozalla MD, et al. The prevalence of HFE C282Y gene mutation is increased in Spanish patients with porphyria cutanea tarda without hepatitis C virus infection. *J Eur Acad Dermatol Venereol* 2006;20:1201-6. ([Abstract](#))
- Troisier M. Diabete sucre. *Bull Soc Anatom (Paris)* 1871;16:231-5.
- Trosseau A. Glucosurie: Diabete sucre. *Bull Soc Anatom (Paris)* 1865;2:663.
- U.S. Preventive Services Task Force. Screening for Hemochromatosis: Recommendation Statement. *Am Fam Phys* 2007;75:11-21.
- Vaiopoulos G, Papanikolaou G, Politou M, et al. Arthropathy in juvenile hemochromatosis. *Arthritis Rheum* 2003;48:227-30. ([Abstract](#))
- Vichinsky E, Fischer R, Pakbaz Z, et al. Satisfaction and convenience of chelation therapy in patients with sickle cell disease (SCD): comparison between deferasirox (Exjade®, ICL670) and deferoxamine (DFO). *Blood* 2005;106:A2334.
- Vulpe CD, Kuo YM, Murphy TL, et al. Hephaestin, a ceruloplasmin homologue implicated in intestinal iron transport, is defective in the sla mouse. *Nat Genet* 1999;21:195-9. ([Abstract](#))
- Wallace DF, Clark RM, Harley HA, et al. Autosomal dominant iron overload due to a novel mutation of ferroportin1 associated with parenchymal iron loading and cirrhosis. *J Hepatol* 2004;40:710-3. ([Abstract](#))
- Yaouanq JM. Diabetes and hemochromatosis: current concepts, management and prevention. *Diabete et Metabolisme. (Paris)* 1995;21:319-29. ([Abstract](#))
- Zhang AS, Xiong S, Tsukamoto H, et al. Localization of iron metabolism-related mRNAs in rat liver indicate that HFE is expressed predominantly in hepatocytes. *Blood* 2004;103:1509-14. ([Abstract](#))
- Zurlo MG, De Stefano P, Borgna-Pignatti C, et al. Survival and causes of death in thalassaemia major. *Lancet* 1989;2:27-30. ([Abstract](#))

## 25. NAFLD and NASH

*Claus Niederau*

### Introduction

Both non-alcoholic fatty liver disease (NAFLD) and non-alcoholic steatohepatitis (NASH) are often associated with obesity, diabetes mellitus and asymptomatic elevations of serum ALT and gamma GT. Ultrasound monitoring can suggest the presence of a fatty infiltration of the liver; differentiation between NAFLD and NASH, however, requires a liver biopsy. Such differentiation may be important because NASH is associated with a much higher risk of liver fibrosis and cirrhosis than NAFLD. Moderate weight loss due to dietary and life-style modifications is the only therapy proven to be effective in NASH. Complete alcohol abstinence and good control of diabetes mellitus are probably also important to reduce the risk of severe liver disease in NASH.

### Prevalence

NAFLD is present in the general population in industrialized countries in 20 to 40% and is the most prevalent chronic liver disease (Browning 2004, Chitturi 2004, McCullough 2005). It is more prevalent in obese and diabetic subjects (Bellentani 1994, Wanless 1990, Clark 2002, Chitturi 2004). Among all subjects with NAFLD, features of non-alcoholic steatohepatitis (NASH) can be seen in 10-20%. The prevalence of NASH in western countries is approximately 2-6%. In the US, NASH is estimated to affect 5-6% of the general population (McCullough 2005). It has been suggested that NASH accounts for more than 50% of cryptogenic cirrhosis (Ratziu 2002). NAFLD may progress to NASH with fibrosis, cirrhosis, and hepatocellular carcinoma (Marchesini 2003, Caldwell 2004). The term NASH was introduced in a description of 20 Mayo Clinic patients with a hitherto unnamed disease associated with hepatomegaly, abnormal ALT, a fatty liver histology, lobular hepatitis, and fibrosis mimicking alcoholic hepatitis in the absence of alcohol intake (Ludwig 1980); most patients had obesity and diabetes mellitus.

## Demographics and risk factors

In the US, NAFLD is 3-5 times more prevalent in men than in women; such differences in gender might partly be explained by the fact that men have a higher BMI and that some male patients with NAFLD drink more alcohol than they report drinking (Schwimmer 2005, Bahcecioglu 2006, Loguercio 2001). The NAFLD prevalence in the US is particularly high in people of Hispanic (28%) or Asian origin (20-30%) (Schwimmer 2005, Weston 2005). Due to the dramatic increase in obesity in the US and many other industrialized countries, there is also a dramatic increase in the prevalence of NAFLD and NASH. In the US almost 50% of obese boys have NAFLD (Schwimmer 2005). In many countries more than 80% of NAFLD patients have an increased BMI and 30-40% are obese; approximately 50% show signs of insulin resistance, 20-30% have type 2 diabetes, 80% show hyperlipidemia, and 30-60% have arterial hypertension. Correspondingly there is a strong association between NAFLD and NASH and the metabolic syndrome throughout the world (Marchesini 1999, Bedogni 2005). In comparison with NAFLD patients, NASH patients are older, more obese and more often have high serum liver enzymes, diabetes mellitus and metabolic syndrome (Ratziu 2002, Adams 2005, Hamaguchi 2005, Fassio 2004).

## Pathogenesis

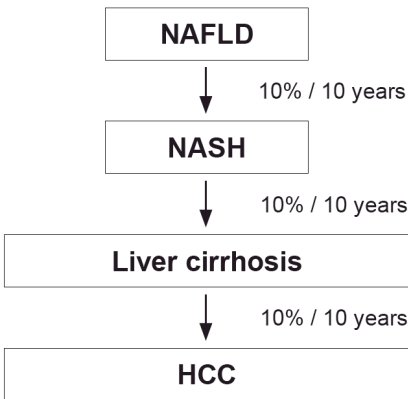
The degree of fatty infiltration in NAFLD is graded according to the percentage of hepatocytes with fat deposits: mild NAFLD involves less than 30% hepatocytes, moderate NAFLD up to 60%, and severe NAFLD above 60% (Ploeg 1993). NAFLD may regress if the cause is eliminated. NASH is associated with insulin resistance, increased circulating levels of leptin, adiponectin, tumour necrosis factor and some interleukins (Friedman 1998, Marra 2004). It is thought that there is an increased flow of free fatty acids from visceral fat to the liver contributing to abnormalities in intracellular lipid metabolism (Hashimoto 1999, Vendemiaie 2001). Insulin resistance and increased free fatty acids may both affect mitochondrial oxidation of fatty acids causing free radical generation in hepatocytes (Grattagliano 2003). Thus, NASH is caused by two mechanisms or toxic "hits"; the first mechanism is the hepatic accumulation of triglycerides (NAFLD) due to insulin resistance and the second is thought to be the generation of free radicals with subsequent release of mediators and cytokines (McCullough 2006).

Insulin resistance has been closely linked to non-alcoholic fatty liver disease in both clinical trials and laboratory-based studies (McCullough 2006, Marchesini 2001, Sanyal 2001). The actual process by which NAFLD turns into NASH however remains ill defined despite this double-hit theory. Likely, genetic factors (similar to those responsible for the metabolic syndrome) as well as exogenic factors (like drugs, moderate amounts of alcohol, and other toxins) may contribute to the evolution of NAFLD into NASH. The role of hepatic iron in the progression of NASH remains controversial, but in some patients, iron may have a role in the pathogenesis of NASH by promoting oxidative stress. Iron overload has been shown to cause lipid peroxidation and to activate hepatic stellate cells (Lee 1995). In some reports, an increased prevalence of the Cys282Tyr HFE gene mutation in patients with NASH has been reported (George 1998). The presence of the Cys282Tyr

mutation was associated with increased hepatic iron concentration that in turn is associated with the severity of the fibrosis. Other studies have shown that other heterozygote HFE gene mutations are more prevalent in NASH patients when compared with controls (Bonkowsky 1999). In another clinical cohort, there was no association between hepatic iron and histological or clinical outcome (Younoussi 1999).

## Natural history

The natural history of NAFLD in the general population is not well-defined since most data come from selected patients and tertiary centres (Dam-Larsen 1996, Lee 1989, Teli 1995). Correspondingly, published mortality and morbidity in hospitalized NAFLD are approximately 5 times higher than what is seen in the general population (Matteoni 1999). In the general population the risk for liver-related death in NAFLD appears to be associated mainly with age, insulin resistance, and histological evidence of hepatic inflammation and fibrosis (Adams 2005). Probably around 10% of NAFLD patients will progress to NASH over a period of 10 years (Figure 1). Cirrhosis later develops in 5-25% of patients with NASH and 30-50% of these patients die from liver-related causes over a 10-year period (McCollough 2005, Matteoni 1999). Cirrhosis in patients with NASH can also decompensate into subacute liver failure, progress to hepatocellular cancer (HCC), and recur after liver transplantation (McCollough 2005). Steatosis alone is reported to have a more benign clinical course, with cirrhosis developing in only 1-3% of patients (Day 2004, Day 2005, McCollough 2005, Matteoni 1999). Patients with NASH and fibrosis also have a significant risk for hepatocellular carcinoma (El-Serag 2004) (Figure 1).



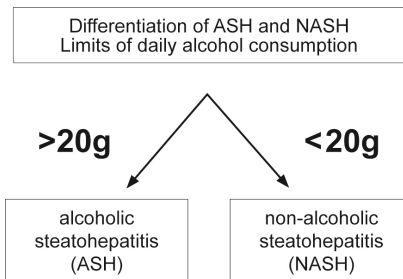
**Figure 1. Natural history of NASH.**

**Table 1. Non-invasive predictors of NASH.**

<p><b>HAIR index (hypertension; ALT &gt;40 U/l; insulin resistance)</b>          ≥2 are 80% sensitive, 89% specific for NASH (Dixon 2001)</p> <p><b>BAAT index (BMI &gt;28; Age &gt;50 years; ALT &gt;2x UNL; increased trig's)</b>          ≤1 has 100% negative predictive value for NASH (Ratziu 2000)</p>
---

## Diagnosis

NAFLD and NASH require valid reporting about alcohol consumption. Since only approximately 10% of western populations are completely abstinent from alcohol, one needs to set a threshold above which one assumes that alcohol at least contributes to the pathogenic process of NAFLD and NASH. Most authors use a daily alcohol ingestion of 20 g as such a threshold (Figure 2); others use lower values such as 10 g/day or as high as 40 g/day for men.

**Figure 2. Differentiation of alcoholic liver disease (ASH) and NASH.**

The workup of NAFLD and NASH also includes checking into drug abuse, HBV and HCV infections, hemochromatosis, autoimmune liver disease and, in younger patients, Wilson's Disease. In special groups of patients NASH may be accompanied by drug- and alcohol-induced liver disease and by HCV and HBV infections. The combination of NAFLD/NASH and HCV infection plays a particularly important clinical role because in this situation the rate of liver fibrosis is increased and the success of antiviral therapy is diminished (Ramesh 2004). NASH can be induced by various drugs and toxins including corticosteroids, amiodarone, methotrexate, tetracycline, tamoxifen, and valproate (Pessayre 2002) (Table 4). Thus, one needs to carefully assess the full clinical history of patients. In practice NAFLD is often diagnosed by combining elevated levels of ALT and gamma GT with the sonographic appearance of an increase in the echodensity of the liver. However, a considerable number of patients with NAFLD and even with NASH and fibrosis have normal serum liver enzymes (Abrams 2004). Usually ALT is higher than AST unless there is already severe fibrosis or cirrhosis. Fasting serum glucose should be checked in all patients with NAFLD and NASH; one will also often find elevated serum insulin, insulin resistance, and/or diabetes (Table 2).

**Table 2. Treatment options for NASH.****Moderate weight loss**


---

Drugs for treatment of obesity (e.g., orlistat or sibutramine)  
 Complete abstinence from alcohol  
 Good control of diabetes mellitus  
 Insulin sensitizers (e.g., glitazones)  
 Surgery for massive obesity (e.g., gastric bypass surgery)  
 Liver transplant (LTX)

---

Many authors also recommend to routinely look for metabolic syndrome, which is diagnosed when three of the following features are seen (Greenland 2003):

- waist circumference  $\geq 102$  cm for men and  $\geq 88$  cm for women,
- fasting glucose level  $\geq 6.1$  mmol/L,
- triglyceridemia  $\geq 1.7$  mmol/L,
- increase in high-density lipoprotein cholesterol ( $>1.3$  mmol/L in women;  $>1.03$  mmol/L in men)
- hypertension  $\geq 135/80$  mmHg.

Ultrasound of the liver has a high sensitivity and specificity (both approaching 90%) for detection of fatty infiltration but does not allow assessment of the presence or degree of inflammation and fibrosis (Davies 1991). Therefore, diagnosis of fat in the liver is easily made by ultrasound but diagnosis of NAFLD or NASH cannot be made without a liver histology. In addition, liver biopsy is still the only way to reliably differentiate NASH from NAFLD (Harrison 2003). Today most pathologists use the Brunt description to score the histological degree of NASH (Brunt 1999) (Table 3). Since NAFLD is a very frequent but also relatively benign disease, one aims to identify some risks factors for NASH in order to avoid doing liver biopsies in all NAFLD patients. Risk factors for NASH include older age, excessive obesity, diabetes mellitus, other hepatotoxins, and clinical, laboratory or sonographic signs suggesting severe liver disease; two non-invasive scores have been used to predict NASH and might be used to identify patients who should have a liver biopsy (Table 3) (Dixon 2001, Ratzu 2000). Combinations of various serum markers of liver fibrosis and the results from liver stiffness measured by the fibroscan have been suggested to predict the presence of NASH and fibrosis (Rosenberg 2004, Suzuki 2005). These tests have not yet replaced the liver biopsy.

## Diet and lifestyle recommendations

Today, the only effective treatment for NAFLD and NASH is a slow and moderate weight loss, usually associated with other lifestyle modifications. Several studies have shown that rapid weight loss (very low calorie diet or starving) increases the risk of progression of liver disease and even liver failure (Grattagliano 2000, James 1998, Neuschwander-Tetri 2003). Patients should therefore be educated not to induce rapid weight loss, but to aim at a weight loss of less than 10% of their body weight over 6-12 months (Okita 2001). It is unclear whether special diets are helpful; probably it is more important that the patients simply eat healthy foods like vegetables and fruits, rich in fibre and complex carbohydrates with a low glycemic index; they should avoid meat, saturated fat and products with less complex

carbohydrates. Lifestyle modifications should include an increase in physical activity and sports as well as abstinence from alcohol. With the results of recent studies, coffee consumption does not need to be limited.

**Table 3. Histological Brunt score (Brunt 1999).**

Grade	Steatosis	Ballooning of hepatocytes	Degree of inflammation
1	<33%	Minimal	Mild
2	34-66%	Present	Moderate
3	>66%	Marked	Portal moderate, lobular moderate

Stage	Fibrosis
1	Perisinusoidal
2	Perisinusoidal and portal/periportal
3	Bridging septa
4	Extensive bridging fibrosis, cirrhosis

## Pharmacological treatment

There is no drug proven to be beneficial in NAFLD and NASH; therefore no drug has been approved by FDA or EMA. Drugs that might reverse insulin resistance such as metformin and thiazolidinediones (rosiglitazone, pioglitazone) seemed to be most promising, but have so far not been proven to be beneficial (Angelico 2007). In addition marketing of rosiglitazone was discontinued due to safety concerns. The distribution of pioglitazone was stopped in some countries due to similar reasons.

In general all drugs that induce weight loss might be beneficial in NAFLD and NASH, in particular when diet and life-style modification do not work (Table 5). Both sibutramine and orlistat have shown to improve some characteristics of NAFLD and NASH such as the sonographic degree of liver steatosis as well as the histological degree of steatosis and fibrosis (Sabuncu 2003, Derosa 2004, Hussein 2007, Harrison 2007).

Antioxidants and cytoprotective substances have also been proposed to treat NAFLD and NASH including vitamin E, vitamin C, glutathione, betaine, acetylcysteine, S-adenosyl-L-methionine and ursodesoxycholic acid. After a recent Cochrane analysis, none of these substances has shown significant benefit in validated randomized studies (Lirussi 2007).

## Surgery for obesity

Gastric bypass has also recently been shown to improve NASH (Liu 2007, de Almeida 2006, Furuya 2007); however, surgery is usually restricted to patients with massive obesity.



## Liver transplantation (LTX) for NASH

LTX is the final option for patients with end-stage liver disease due to cirrhosis and complications of portal hypertension with NASH. Due to the increase in the prevalence of NASH, there is also an increase in LTX done for end-stage liver disease caused by NASH (Burke 2004). However, NASH can recur after LTX, particularly if patients have previously undergone jejunoileal bypass surgery (Kim 1996, Requart 1995, Weston 1998, Contos 2001, Burke 2004). LTX does not cure the metabolic defect that causes NASH.

## References

- Abrams GA, Kunde SS, Lazenby AJ, Clements RH. Portal fibrosis and hepatic steatosis in morbidly obese subjects: a spectrum of nonalcoholic fatty liver disease. *Hepatology* 2004;40:475-83. ([Abstract](#))
- Adams LA, Lymp JF, Sauver SJ, et al. The natural history of nonalcoholic fatty liver disease: a population-based cohort study. *Gastroenterology* 2005;129:113-21. ([Abstract](#))
- Adams LA, Sanderson S, Lindor KD, Angulo P. The histological course of nonalcoholic fatty liver disease: a longitudinal study of 103 patients with sequential liver biopsies. *J Hepatol* 2005;42:132-8. ([Abstract](#))
- Angelico F, Burattin M, Alessandri C, Del Ben M, Lirussi F. Drugs improving insulin resistance for non-alcoholic fatty liver disease and/or non-alcoholic steatohepatitis. *Cochrane Database Syst Rev* 2007;24:CD005166. ([Abstract](#))
- Bahcecioglu IH, Koruk M, Yilmaz O, et al. Demographic and clinicopathological characteristics of nonalcoholic fatty liver disease in the east-southeastern Anatolia regions in Turkey. *Med Princ Pract* 2006;15:62-8. ([Abstract](#))
- Bedogni G, Miglioli L, Masutti F, Tiribelli C, Marchesini G, Bellentani S. Prevalence of and risk factors for nonalcoholic fatty liver disease: the Dionysos nutrition and liver study. *Hepatology* 2005;42:44-52. ([Abstract](#))
- Belfort R, Harrison SA, Brown K, et al. A placebo-controlled trial of pioglitazone in subjects with nonalcoholic steatohepatitis. *N Engl J Med* 2006;355:2297-307. ([Abstract](#))
- Bellentani S, Tiribelli C, Saccoccio G, et al. Prevalence of chronic liver disease in the general population of northern Italy: the Dionysos Study. *Hepatology* 1994;20:1442-9. ([Abstract](#))
- Bonkovsky HL, Jawaid Q, Tortorelli K, et al. Non-alcoholic steatohepatitis and iron: increased prevalence of mutations of the HFE gene in non-alcoholic steatohepatitis. *J Hepatol* 1999;31:421-9. ([Abstract](#))
- Browning JD, Szczepaniak LS, Dobbins R, et al. Prevalence of hepatic steatosis in an urban population in the United States: impact of ethnicity. *Hepatology* 2004;40:1387-95. ([Abstract](#))
- Brunt EM, Janney CG, Di Bisceglie AM, Neuschwander-Tetri BA, Bacon BR. Nonalcoholic steatohepatitis: a proposal for grading and staging the histological lesions. *Am J Gastroenterol* 1999;94:2467-74. ([Abstract](#))
- Burke A, Lucey MR. Non-alcoholic fatty liver disease, non-alcoholic steatohepatitis and orthotopic liver transplantation. *Am J Transplant* 2004;4:686-93. ([Abstract](#))
- Caldwell SH, Crespo DM. The spectrum expanded: cryptogenic cirrhosis and the natural history of non-alcoholic fatty liver disease. *J Hepatol* 2004;40:578-84. ([Abstract](#))
- Chitturi S, Farrell GC, George J. Non-alcoholic steatohepatitis in the Asia-Pacific region: future shock. *J Gastroenterol Hepatol* 2004;19:368-74. ([Abstract](#))
- Clark JM, Brancati FL, Diehl AM. Nonalcoholic fatty liver disease. *Gastroenterology* 2002;122:1649-57 ([Abstract](#))
- Contos MJ, Cales W, Sterling RK, et al. Development of nonalcoholic fatty liver disease after orthotopic liver transplantation for cryptogenic cirrhosis. *Liver Transpl* 2001;7:363-73. ([Abstract](#))
- Davies RJ, Saverymuttu SH, Fallowfield M, Joseph AE. Paradoxical lack of ultrasound attenuation with gross fatty change in the liver. *Clin Radiol* 1991;43:393-6. ([Abstract](#))
- Day CP. The potential role of genes in nonalcoholic fatty liver disease. *Clin Liver Dis* 2004;8:673-91. ([Abstract](#))

- Day CP. Natural history of NAFLD: remarkably benign in the absence of cirrhosis. *Gastroenterology* 2005;129:375-8. ([Abstract](#))
- Dam-Larsen S, Franzmann M, Andersen IB, et al. Long term prognosis of fatty liver: risk of chronic liver disease and death. *Gut* 2004;53:750-5 ([Abstract](#))
- de Almeida SR, Rocha PR, Sanches MD, et al. Roux-en-Y gastric bypass improves the nonalcoholic steatohepatitis (NASH) of morbid obesity. *Obes Surg* 2006;16:270-8. ([Abstract](#))
- Derosa G, Cicero AF, Murdolo G, Ciccarelli L, Fogari R. Comparison of metabolic effects of orlistat and sibutramine treatment in Type 2 diabetic obese patients. *Diabetes Nutr Metab* 2004;17:222-9. ([Abstract](#))
- Dixon JB, Bhathal PS, O'Brien PE. Nonalcoholic fatty liver disease: predictors of nonalcoholic steatohepatitis and liver fibrosis in the severely obese. *Gastroenterology* 2001; 21:91-100. ([Abstract](#))
- El-Serag HB, Tran T, Everhart JE. Diabetes increases the risk of chronic liver disease and hepatocellular carcinoma. *Gastroenterology* 2004;126:460-8 ([Abstract](#))
- Fassio E, Alvarez E, Dominguez N, Landeira G, Longo C. Natural history of nonalcoholic steatohepatitis: a longitudinal study of repeat liver biopsies. *Hepatology* 2004;40:820-6. ([Abstract](#))
- Friedman JM, Halaas JL. Leptin and the regulation of body weight in mammals. *Nature* 1998;395:763-70. ([Abstract](#))
- George DK, Goldwurm S, MacDonald GA, et al. Increased hepatic iron concentration in nonalcoholic steatohepatitis is associated with increased fibrosis. *Gastroenterology*. 1998;114:311-8. ([Abstract](#))
- Grattagliano I, Caraceni P, Portincasa P, et al. Adaptation of subcellular glutathione detoxification system to stress conditions in choline-deficient diet induced rat fatty liver. *Cell Biol Toxicol* 2003;19:355-66. ([Abstract](#))
- Grattagliano I, Portincasa P, Palmieri VO, Palasciano G. Managing nonalcoholic fatty liver disease. Recommendations for family physicians. *Can Fam Physician* 2007;53:857-63. ([Abstract](#))
- Furuya CK Jr, de Oliveira CP, de Mello ES, et al. Effects of bariatric surgery on nonalcoholic fatty liver disease: preliminary findings after 2 years. *J Gastroenterol Hepatol*. 2007;22:510-4. ([Abstract](#))
- Harrison SA, Torgerson S, Hayashi PH. The natural history of nonalcoholic fatty liver disease: a clinical histopathological study. *Am J Gastroenterol* 2003;98:2042-7 ([Abstract](#))
- Harrison SA, Fincke C, Helinski D, Torgerson S, Hayashi P. A pilot study of orlistat treatment in obese, non-alcoholic steatohepatitis patients. *Aliment Pharmacol Ther* 2004;20:623-8. ([Abstract](#))
- Hashimoto T, Fujita T, Usuda N, et al. Peroxisomal and mitochondrial fatty acid beta-oxidation in mice nullizygous for both peroxisome proliferator-activated receptor alpha and peroxisomal fatty acyl-CoA oxidase. Genotype correlation with fatty liver phenotype. *J Biol Chem* 1999;274:19, 228-36.
- Hussein O, Grosovski M, Schlesinger S, Szvalb S, Assy N. Orlistat reverse fatty infiltration and improves hepatic fibrosis in obese patients with nonalcoholic steatohepatitis (NASH). *Dig Dis Sci* 2007;52:2512-9. ([Abstract](#))
- Grattagliano I, Vendemiale G, Caraceni P, et al. Starvation impairs antioxidant defense in fatty livers of rats fed a choline-deficient diet. *J Nutr* 2000;130:2131-6. ([Abstract](#))
- Greenland P, Knoll MD, Stamler J, et al. Major risk factors as antecedents of fatal and nonfatal coronary heart disease events. *JAMA* 2003;290:891-7. ([Abstract](#))
- Hamaguchi M, Kojima T, Takeda N, et al. The metabolic syndrome as a predictor of nonalcoholic fatty liver disease. *Ann Intern Med* 2005;143:722-8. ([Abstract](#))
- Hussein O, Grosovski M, Schlesinger S, Szvalb S, Assy N. Orlistat reverse fatty infiltration and improves hepatic fibrosis in obese patients with nonalcoholic steatohepatitis (NASH). *Dig Dis Sci* 2007;52:2512-9. ([Abstract](#))
- James OF, Day CP. Non-alcoholic steatohepatitis (NASH): a disease of emerging identity and importance. *J Hepatol* 1998;29:495-501. ([Abstract](#))
- Kim WR, Poterucha JJ, Porayko MK, Dickson ER, Steers JL, Wiesner RH. Recurrence of nonalcoholic steatohepatitis following liver transplantation. *Transplantation* 1996;62:1802-5. ([Abstract](#))
- Lee RG. Nonalcoholic steatohepatitis: a study of 49 patients. *Hum Pathol* 1989;20:594-8. ([Abstract](#))

- Lee KS, Buck M, Houghlum K, Chojkier M. Activation of hepatic stellate cells by TGF $\beta$  and collagen type I is mediated by oxidative stress through c-myc expression. *J Clin Invest* 1995;96:2461-2468. (Abstract)
- Lirussi F, Azzalini L, Orlando S, Orlando R, Angelico F. Antioxidant supplements for non-alcoholic fatty liver disease and/or steatohepatitis. *Cochrane Database Syst Rev* 2007;24:CD004996. (Abstract)
- Liu X, Lazenby AJ, Clements RH, Jhala N, Abrams GA. Resolution of nonalcoholic steatohepatitis after gastric bypass surgery. *Obes Surg* 2007;17:486-92.
- Loguercio C, De Girolamo V, de Sio I, et al. Non-alcoholic fatty liver disease in an area of southern Italy: main clinical, histological, and pathophysiological aspects. *J Hepatol* 2001;35:568-74. (Abstract)
- Ludwig J, Viggiano TR, McGill DB, Oh BJ. Nonalcoholic steatohepatitis: Mayo Clinic experiences with a hitherto unnamed disease. *Mayo Clin Proc* 1980;55:434-8. (Abstract)
- Marchesini G, Brizi M, Bianchi G, et al. Nonalcoholic fatty liver disease: a feature of the metabolic syndrome. *Diabetes* 2001;50:1844-50. (Abstract)
- Marchesini G, Brizi M, Morselli-Labate AM, et al. Association of nonalcoholic fatty liver disease with insulin resistance. *Am J Med* 1999;107:450-5. (Abstract)
- Marchesini G, Bugianesi E, Forlani G, et al. Nonalcoholic fatty liver, steatohepatitis, and the metabolic syndrome. *Hepatology* 2003;37:917-23. (Abstract)
- Matteoni CA, Younossi ZM, Gramlich T, Boparai N, Liu YC, McCullough AJ. Nonalcoholic fatty liver disease: a spectrum of clinical and pathological severity. *Gastroenterology* 1999;116:1413-9. (Abstract)
- Marra F. NASH: are genes blowing the hits? *J Hepatol* 2004;40:853-6 (Abstract)
- McCullough AJ. Pathophysiology of nonalcoholic steatohepatitis. *J Clin Gastroenterol* 2006;40:1:S17-S29. (Abstract)
- McCullough AJ. The epidemiology and risk factors of NASH. In: Farrell GC, George J, Hall P, McCullough AJ eds. *Fatty liver disease: NASH and related disorders*. Malden, MA: Blackwell, 2005:23-37.
- Neuschwander-Tetri BA, Caldwell SH. Nonalcoholic steatohepatitis: summary of an AASLD Single Topic Conference. *Hepatology* 2003;37:1202-19. (Abstract)
- Okita M, Hayashi M, Sasagawa T, et al. Effect of a moderately energy-restricted diet on obese patients with fatty liver. *Nutrition* 2001;17:542-7 (Abstract)
- Pessayre D, Berson A, Fromenty B, Mansouri A. Mitochondria in steatohepatitis. *Semin Liver Dis* 2001;21:57-69. (Abstract)
- Ploeg RJ, D'Alessandro AM, Knechtle SJ, Stegall MD, Pirsch JD, Hoffmann RM, et al. Risk factors for primary dysfunction after liver transplantation—a multivariate analysis. *Transplantation* 1993;55:807-13 (Abstract)
- Ramesh S, Sanyal AJ. Hepatitis C and nonalcoholic fatty liver disease. *Semin Liver Dis* 2004;24:399-413 (Abstract)
- Ratziu, et al. Liver Fibrosis in Overweight Patients. *Gastroenterology* 2000;118:1117-23. (Abstract)
- Ratziu V, Bonyhay L, Di Martino V, et al. Survival, liver failure, and hepatocellular carcinoma in obesity-related cryptogenic cirrhosis. *Hepatology* 2002;35:1485-93. (Abstract)
- Requarth JA, Burchard KW, Colacchio TA, et al. Long-term morbidity following jejunoileal bypass: the continuing potential need for surgical reversal. *Arch Surg* 1995;130:318-25. (Abstract)
- Rosenberg WM, Voelker M, Thiel R, et al. Serum markers detect the presence of liver fibrosis: a cohort study. *Gastroenterology* 2004;127:1704-13. (Abstract)
- Sabuncu T, Nazligul Y, Karaoglanoglu M, Ucar E, Kilic FB. The effects of sibutramine and orlistat on the ultrasonographic findings, insulin resistance and liver enzyme levels in obese patients with non-alcoholic steatohepatitis. *Rom J Gastroenterol* 2003;12:189-92. (Abstract)
- Sanyal AJ, Campbell-Sargent C, Mirshahi F, et al. Nonalcoholic steatohepatitis: association of insulin resistance and mitochondrial abnormalities. *Gastroenterology* 2001;120:1183-92. (Abstract)
- Schwimmer JB, McGreal N, Deutsch R, Finegold MJ, Lavine JE. Influence of gender, race, and ethnicity on suspected fatty liver in obese adolescents. *Pediatrics* 2005 115:561-5. (Abstract)

## 436 Hepatology 2012

- Suzuki A, Angulo P, Lymp J, Li D, Satomura S, Lindor K. Hyaluronic acid, an accurate serum marker for severe hepatic fibrosis in patients with non-alcoholic fatty liver disease. *Liver Int* 2005;25:779-86 ([Abstract](#))
- Teli MR, James OF, Burt AD, Bennett MK, Day CP. The natural history of nonalcoholic fatty liver: a follow-up study. *Hepatology* 1995;22:1714-9 ([Abstract](#))
- Vendemiale G, Grattagliano I, Caraceni P, et al. Mitochondrial oxidative injury and energy metabolism alteration in rat fatty liver: effect of the nutritional status. *Hepatology* 2001;33:808-15 ([Abstract](#))
- Wanless IR, Lentz JS. Fatty liver hepatitis (steatohepatitis) and obesity: an autopsy study with analysis of risk factors. *Hepatology* 1990;12:1106-10. ([Abstract](#))
- Weston S, Charlton MR, Lindor KD. Liver transplantation for nonalcoholic steatohepatitis. *Gastroenterology* 1998;114:A1364.
- Weston SR, Leyden W, Murphy R, et al. Racial and ethnic distribution of nonalcoholic fatty liver in persons with newly diagnosed chronic liver disease. *Hepatology* 2005;41:372-9. ([Abstract](#))
- Younossi ZM, Gramlich T, Bacon BR, et al. Hepatic iron and nonalcoholic fatty liver disease. *Hepatology* 1999;30:847-50. ([Abstract](#))

## 26. Wilson's Disease

*Claus Niederau*

### Introduction

In 1912, Kinnear Wilson was the first to describe an inherited lethal disease associated with progressive lenticular degeneration, chronic liver disease and cirrhosis (Wilson 1912). In the same year, Kayser and Fleischer detected that patients with Wilson's Disease (WD) often have brownish corneal copper deposits now called Kayser-Fleischer rings (Fleischer 1912).

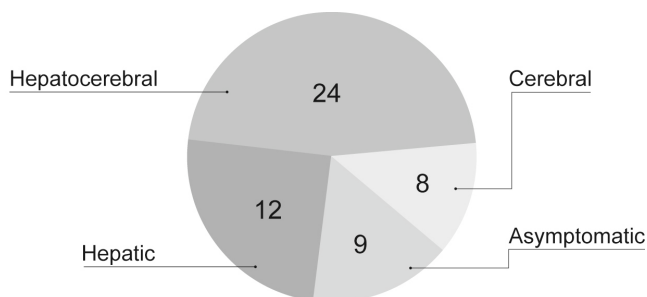
WD is an autosomal recessive error of the metabolism. Its gene ATP7B encodes a copper-transporting ATPase (Bull 1993, Tanzi 1993, Petrukhin 1993, Yamaguchi 1993). The genetic defect of the ATP7B protein reduces biliary copper excretion leading to copper accumulation in the cornea and various organs including the liver, brain and kidney. The alteration of the ATP7B protein also reduces the incorporation of copper into ceruloplasmin. The corresponding presence of apoceruloplasmin (ceruloplasmin with no copper incorporation) leads to a decrease in circulating levels of ceruloplasmin due to the reduced half-life of the apoprotein. Thus, despite copper accumulation in many organs, circulating levels of copper and ceruloplasmin are decreased in most WD patients.

The prevalence of WD is rare, estimated at 3 per 100,000 population (Frysman 1990). The clinical presentation may vary. Some WD patients are diagnosed with liver problems while others present with neurologic or psychiatric symptoms; many patients show both hepatic and neurological disease (Figure 1). Episodes of hemolysis and renal abnormalities may also occur. WD typically affects children and younger adults, and is rarely seen in adults older than 40. WD is fatal unless appropriately treated. Drugs for treatment of WD are copper chelators such as penicillamine, and trientine (Walshe 1956). More recently, zinc has been used to reduce intestinal copper absorption and to detoxify free circulating copper. Patients with fulminant liver failure or decompensated cirrhosis may have to undergo liver transplantation (LTX), which cures WD.

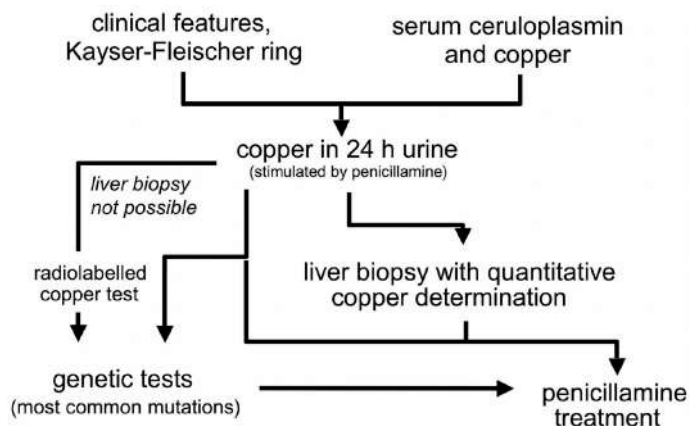
### Clinical presentation

Screening for WD is useful only in families with an affected member. In all other circumstances diagnostic procedures are only done when symptoms and findings suggest WD. These include liver disease, neurological symptoms, renal

abnormalities and episodes of hemolysis. WD is diagnosed in the vast majority of patients between the ages of 5 and 35. There are rare reports of patients diagnosed at ages 3-5 (Kalach 1993, Wilson 2000) and at ages of up to about 60 years (Gow 2000). Late-onset WD is a frequently overlooked condition (Ferenci 2007). Diagnostic workup does not rely on a single test but includes identification of corneal Kayser-Fleischer rings, reduced serum ceruloplasmin and copper as well as a quantitative determination of liver copper concentration (Scheinberg 1952, Walshe 1956, Saito 1987, Stremmel 1991, Roberts 2003) (Figure 2).



**Figure 1. Clinical course of WD in 53 patients** (modified from Stremmel 1991).



**Figure 2. Diagnostic workup for WD.**

Genetic tests are usually only done in relatives of a confirmed WD patient. It is easy to diagnose WD in subjects who present with liver cirrhosis, typical neurologic manifestations and Kayser-Fleischer rings; many of these patients present at ages 5 to 35 and have decreased serum copper and ceruloplasmin (Sternlieb 1990). However, a considerable number of WD patients present only with liver disease and may not have Kayser-Fleischer rings or decreased serum levels of ceruloplasmin (Steindl 1997). Under these circumstances diagnosis may be difficult; measurement of 24 hour urinary copper excretion often helps to support the suspicion of WD.

Liver biopsy with measurement of quantitative copper concentration should be done to corroborate the diagnosis (Stremmel 1991, Roberts 2003).

In general, WD patients diagnosed primarily with liver disease are children and adolescents and are younger than those diagnosed due to neurological symptoms (Merle 2007). Many patients who present only with CNS symptoms are 20-40 years old. Patients with WD may present with a wide spectrum of liver disease ranging from asymptomatic elevation of serum aminotransferases to fulminant liver failure. Serum aminotransferases are elevated in most WD patients irrespective of age (Schilsky 1991). Other WD patients may present with findings and symptoms of autoimmune hepatitis including autoimmune antibodies and elevated IgG (Scott 1978, Milkiewicz 2000). The clinical picture might also resemble acute or chronic viral hepatitis, without the viral serum markers. Even liver histology is not predictive or typical for WD unless copper concentration is measured. Histological findings may range from fatty liver changes to severe necro-inflammatory and fibrotic disease and complete cirrhosis. In particular, children and adolescents with chronic active hepatitis of unknown etiology or autoimmune hepatitis and adult patients with a suspicion of autoimmune hepatitis or non-response to immunosuppressants should be evaluated for WD (Roberts 2003).

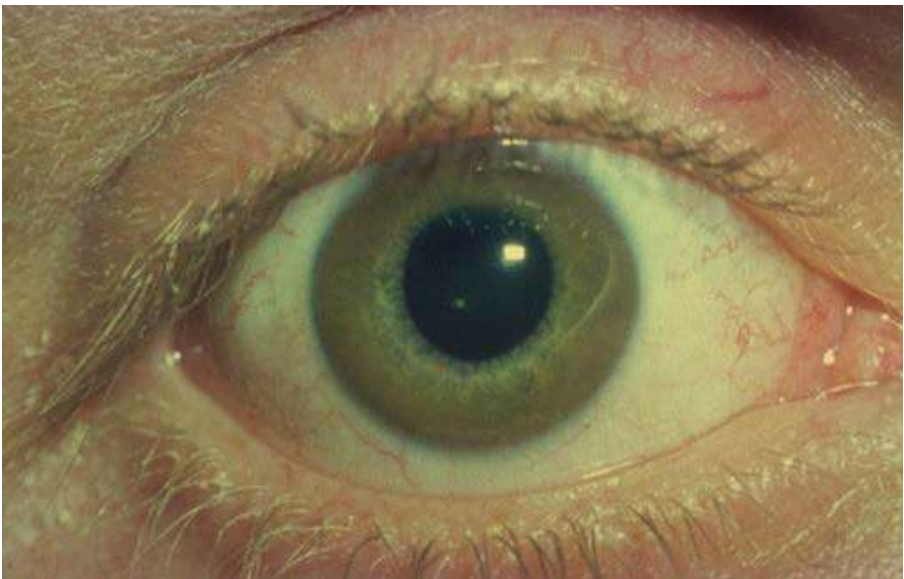
WD has to be excluded in patients with fulminant liver failure of unknown etiology, especially at ages under 35 years; WD patients with such presentation usually have some sort of liver disease (Rector 1984, Ferlan-Maroult 1999, Roberts 2003) associated with Coombs-negative hemolytic anemia and severely increased prothrombine time non-responsive to vitamin K and progressive renal failure (Sallie 1992). Some patients have bilirubin levels of more than 40 mg/dl while serum alkaline phosphatase is normal or just slightly elevated (Berman 1991). In contrast to many types of toxic liver failure, liver failure in WD usually does not start with high increases in aminotransferases. In many WD patients AST levels exceed ALT levels (Emre 2001, Berman 1991). In most cohorts, for unexplained reasons, the ratio of females to males is approximately 2:1 (Roberts 2003). Serum ceruloplasmin may be decreased while serum copper and 24-hour urinary excretion of copper is usually elevated. It is extremely helpful when one can identify Kayser-Fleischer rings in this situation; these patients need to be studied with a slit lamp by an experienced ophthalmologist. Patients with acute liver failure need a diagnostic workup as rapidly as possible; if there is a strong suspicion or diagnosis of WD, the patient should be transferred to a transplant centre the same day.

Neurological symptoms in WD often resemble those seen in Parkinson's disease including tremor and rigor. Many patients report that symptoms start with problems in handwriting and dysarthria. Neurological symptoms may be associated with slight behavioural alterations, which may later proceed to manifest psychiatric disease including depression, anxiety and psychosis. With the progression of CNS involvement WD patients may develop seizures and pseudobulbar palsy associated with severe dysphagia, aspiration and pneumonia. Although many older WD patients present with neurological disease, the diagnostic workup often shows significant liver involvement or even complete liver cirrhosis.

Renal involvement of WD may present with aminoaciduria and nephrolithiasis (Azizi 1989, Nakada 1994, Cu 1996). There may be various other non-neurological and non-hepatic complications of WD such as osteoporosis and arthritis,

cardiomyopathy, pancreatitis, hypoparathyroidism, and miscarriages (for literature see Roberts 2003).

Kayser-Fleischer rings are caused by corneal copper deposition (Figure 3). Sometimes, one can see the rings directly as a band of brown pigment close to the limbus. In other patients the ring can only be identified using a slit lamp. Very rarely similar rings may be seen in non-WD patients, e.g., in some patients with neonatal or chronic cholestasis (Tauber 1993). Kayser-Fleischer rings are detectable in 50-60% of WD patients in most large cohorts (Tauber 1993, Roberts 2003). Many young WD patients with liver disease do not have such rings (Giacchino 1997) whereas almost all patients with primarily neurologic symptoms do have them (Steindl 1997). WD patients may also have other less specific eye changes including sunflower cataracts (Cairns 1963). Kayser-Fleischer rings usually regress with chelation therapy or after LTX (Stremmel 1991, Schilsky 1994).



**Figure 3. Kayser-Fleischer ring in a patient with WD.**

## **Diagnosis**

### **Serum ceruloplasmin**

Ceruloplasmin, the major circulating copper transporter, is synthesized and secreted mainly by hepatocytes. The 132 kd protein consists of six copper atoms per molecule of ceruloplasmin (holoceruloplasmin) while the remaining part of the protein does not carry copper (apoceruloplasmin). Ceruloplasmin acts as an acute phase reactant and may thus be increased by any inflammatory process; it may also rise in pregnancy and with the use of estrogens and oral contraceptives. One also needs to remember that the normal range of serum ceruloplasmin is age-dependent: it is usually low in infants until the age of 6 months; in older children it may be



somewhat higher than in adults. As explained previously, serum levels of ceruloplasmin are generally decreased in WD; however, this finding alone is unreliable because low serum ceruloplasmin may be seen without WD and serum ceruloplasmin may even be increased in severe WD and liver failure. Non-specific reductions of ceruloplasmin are usually associated with protein deficiency or any end-stage liver disease. Long-term parenteral nutrition may also lead to decreased levels of ceruloplasmin. Low serum ceruloplasmin is also a hallmark of Menkes' disease, a very rare X-linked inborn error of metabolism that leads to a defect in copper transport due to mutations in ATP7A (Menkes 1999). Very rarely, one cannot measure serum ceruloplasmin at all. This aceruloplasminemia is a very rare genetic disease caused by mutations in the ceruloplasmin gene; however, patients with aceruloplasminemia develop iron and not copper overload (Harris 1998).

Most patients with WD have a serum ceruloplasmin lower than 20  $\mu\text{g/dl}$ ; this finding is diagnostic for WD however only when there are other findings such as a Kayser-Fleischer corneal ring. In one prospective screening study, ceruloplasmin was measured in 2867 patients presenting with liver disease: only 17 of them had reduced ceruloplasmin levels and only 1 of these subjects had WD (Cauza 1997). Thus decreased ceruloplasmin had a positive predictive value of only 6% in the 2867 patients tested. In two cohorts, about 20% of WD had normal ceruloplasmin and no Kayser-Fleischer rings (Steindl 1997, Gow 2000). Most reports, however, show that more than 90% of WD patients have a reduced serum ceruloplasmin (Walshe 1989, Lau 1990, Stremmel 1991). Measurement of ceruloplasmin as a single marker cannot reliably differentiate homozygotes from heterozygotes.

## Serum copper

Corresponding to the decrease in serum ceruloplasmin, total serum copper is also usually decreased in WD. Similar to the diagnostic problems in interpreting ceruloplasmin data in WD patients with fulminant liver failure, serum copper may also be normal in this situation – even if serum ceruloplasmin is decreased. In acute liver failure circulating copper may in fact be elevated because it is massively released from injured hepatocytes. If ceruloplasmin is reduced, a normal or elevated serum copper usually suggests that there is an increase in free serum copper (not bound to ceruloplasmin). The free copper concentration calculated from total copper and ceruloplasmin values has also been proposed as a diagnostic test and for monitoring of WD. It is elevated above 25  $\mu\text{g/dL}$  in most untreated patients (normal values are below 10-15  $\mu\text{g/dL}$ ). The amount of copper associated with ceruloplasmin is 3.15  $\mu\text{g}$  of copper per mg of ceruloplasmin. Thus free copper is the difference between the total serum copper in  $\mu\text{g/dL}$  and 3 times the ceruloplasmin concentration in mg/dl (Roberts 1998).

Increases in serum free copper, however, are not specific for WD and can be seen in all kinds of acute liver failure as well as in marked cholestasis (Gross 1985, Martins 1992). The calculation of the free copper concentration critically depends on the adequacy of the methods used for measuring total serum copper and ceruloplasmin; often labs simply state that one of the tests is below a certain value, which makes it impossible to calculate the amount of free copper.

## Urinary copper excretion

Most WD patients have an increase in urinary copper excretion above 100  $\mu\text{g}/24$  hours, which is thought to represent the increase in circulating free copper (not bound to ceruloplasmin). Some studies suggest that about 20% of WD patients may have 24-hr urinary copper excretion between 40-100  $\mu\text{g}/24$  h (Steindl 1997, Giacchino 1997, Gow 2000, Roberts 2003). However, some increase in urinary copper excretion can be found in severe cholestasis, chronic active hepatitis and autoimmune hepatitis (Frommer 1981). It has been suggested that urinary copper excretion stimulated by penicillamine may be more useful than the non-stimulating test. In children 500 mg of oral penicillamine is usually given at the beginning and then at 12 hours during the 24-hour urine collection. All WD children looked at had levels above 1600  $\mu\text{g}$  copper/24 h and all patients with other liver diseases including autoimmune hepatitis and cholestatic liver disease had lower values. It is not clear whether this test has a similar discriminative power in adults where it has been used in various modifications (Tu 1967, Frommer 1981).

## Hepatic copper concentration

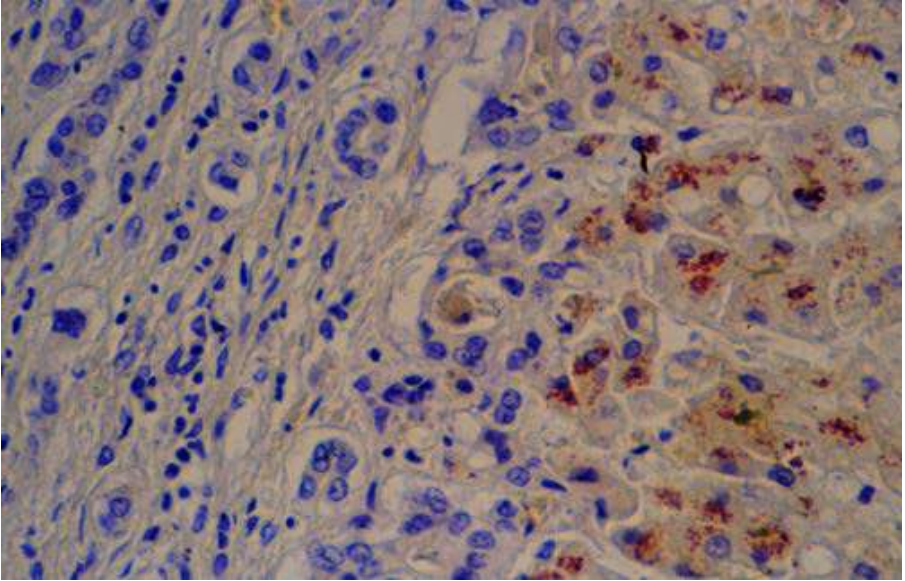
Hepatic copper content above 250  $\mu\text{g}/\text{g}$  dry weight liver is still the gold standard for diagnosis of WD and is not seen in heterozygotes or other liver diseases with the exception of Indian childhood cirrhosis (Martins 1992). Biopsies (larger than 1 cm in length) for measurements of hepatic copper determination should be taken with a disposable Tru-Cut needle, placed dry in a copper-free container and shipped frozen (Song 2000, Roberts 2003).

## Radiolabelled copper

In WD, incorporation of radiolabelled copper into ceruloplasmin is significantly reduced. This test is rarely used because of the difficulty in obtaining the isotope and because of legal restrictions.

## Liver biopsy findings

Histological findings in WD range from some steatosis and hepatocellular necrosis to the picture as seen in severe autoimmune hepatitis with fibrosis and cirrhosis. Patients diagnosed at a young age usually have extensive liver disease; older patients who first present with neurological symptoms often have abnormalities in liver biopsy as well (Stremmel 1991, Steindl 1997, Merle 2007). Detection of copper in hepatocytes, e.g., by staining with rhodamin using routine histochemistry does not allow a diagnosis of WD (Geller 2000) (Figure 4).



**Figure 4.** Liver histology (rhodamine staining for copper) in a WD patient.

## Neurology and MRI of the CNS

Neurologic symptoms in WD include Parkinson's-like abnormalities with rigidity, tremor and dysarthria. In more severely affected patients there may be muscle spasms, contractures, dysphonia, and dysphagia. In patients with pronounced neurological symptoms magnetic resonance imaging (MRI) often identifies abnormalities in basal ganglia such as hyperintensity on T2 weighted imaging (Aisen 1995, van Wassanaer 1996). MRI of the CNS is superior to computed tomography to diagnose WD.

## Genetic Studies

The use of mutation analysis in WD is limited by the fact that more than 200 ATP7B mutations have been described (see [www.medgen.med.ualberta.ca/database.html](http://www.medgen.med.ualberta.ca/database.html)). When the mutation is known in a specific patient, gene analysis may be useful for family screening or prenatal analysis (Thomas 1995, Shab 1997, Loudianos 1994). Some populations in Eastern Europe show predominance of the H1069Q mutation (for literature see Roberts 2003).

## Treatment

Before 1948, all patients with Wilson's Disease died shortly after diagnosis. In 1948, intramuscular administration of the copper chelator BAL (dimercaprol) was introduced as the first treatment of WD (Cumming 1951, Denny-Brown 1951) followed by the oral chelators penicillamine (1955), trientine (1969) and tetrathiomolybdate (1984). Other treatment modalities include oral zinc salts (1961) and liver transplantation (1982). Today, most patients with WD remain on a lifelong

pharmacologic therapy usually including a copper chelator and/or a zinc salt (Figure 5). LTX is reserved for fulminant liver failure and irreversible decompensation of liver cirrhosis. Patients with a successful LTX do not need WD treatment because LTX heals the biochemical defect. Today, most doctors use oral chelators for initial treatment of symptomatic patients; many physicians start therapy with penicillamine while some prefer trientine. Both drugs are probably equally effective, with trientine having fewer side effects. In patients with advanced neurological disease some authors recommend tetrathiomolybdate for primary therapy. Combination therapy of chelators and zinc salts might have additive effects, acting on both urinary copper excretion and its intestinal absorption. After removal of most accumulated copper and regression of the most severe clinical problems the chelator dose may be reduced and later replaced by zinc. Patients presenting without symptoms may be treated with a rather low dose of a chelator or with a zinc salt from the beginning. Compliance problems have been shown to regularly cause recurrence of symptomatic WD and may lead to fulminant liver failure, need for LTX or death.

**Table 1. Treatment options in WD.**

---

<b>Penicillamine</b> (600-1800 mg/day)
In case of intolerance to penicillamine:
<b>Trientine</b> (900-2400 mg/day)
For combination of maintenance:
<b>Zinc acetate/sulfate</b>
For neurologic disease – not yet approved:
<b>Tetrathiomolybdate</b>
In acute liver failure/decompensated cirrhosis:
<b>Liver transplantation</b>
<b>Restriction of food with high copper content</b> (does not substitute for chelators or zinc!)

---

**Penicillamine.** Penicillamine was the first oral copper chelator shown to be effective in WD (Walshe 1955). Total bioavailability of oral penicillamine ranges between 40 and 70% (Bergstrom 1981). Many studies have shown that penicillamine reduces copper accumulation and provides clinical benefit in WD (Walshe 1973, Grand 1975, Sternlieb 1980). Signs of liver disease often regress during the initial 6 months of treatment. Non-compliance has been shown to cause progression of liver disease, liver failure, death and LTX (Scheinberg 1987). However, neurological symptoms may deteriorate at the start of penicillamine treatment; it remains controversial how often this neurological deterioration occurs and whether it is reversible; the rate of neurological worsening ranges from 10-50% in different cohorts (Brewer 1987, Walshe 1993). Some authors even recommend not using penicillamine at all in WD patients with neurological disease (Brewer 2006). Penicillamine is associated with many side effects that lead to its discontinuation in up to 30% of patients (for literature see Roberts 2003). An early sensitivity reaction may occur during the first 3 weeks including fever, cutaneous exanthema, lymphadenopathy, neutropenia, thrombocytopenia, and proteinuria. In such early sensitivity, penicillamine should be replaced by trientine immediately. Nephrotoxicity is another frequent side effect of penicillamine, which occurs later

and includes proteinuria and signs of tubular damage. In this case penicillamine should be immediately discontinued. Penicillamine may also cause a lupus-like syndrome with hematuria, proteinuria, positive antinuclear antibody, and Goodpasture's Syndrome. More rarely the drug can damage the bone marrow leading to thrombocytopenia or total aplasia. Dermatologic side effects include elastosis perforans serpiginosa, pemphigoid lesions, lichen planus, and aphthous stomatitis. There have also been reports of myasthenia gravis, polymyositis, loss of taste, reduction of IgA, and serous retinitis due to administration of penicillamine.

In order to minimize its side effects penicillamine should be started at 250 mg daily; the dose may be increased in 250 mg steps every week to a maximal daily amount of 1000 to 1500 mg given in 2 to 4 divided doses daily (Roberts 2003). Maintenance doses range from 750 to 1000 mg/d given as 2 divided doses. In children the dose is 20 mg/kg/d given in 2 or 3 divided doses. Penicillamine should be given 1 hour before or 2 hours after meals because food may inhibit its absorption. After starting penicillamine therapy serum ceruloplasmin at first may decrease. Treatment success is checked by measuring 24-hr urinary copper that should range between 200-500  $\mu\text{g/day}$ . In the long run ceruloplasmin should increase and free copper should regress towards normal with penicillamine therapy (Roberts 2003).

**Trientine (triene).** The chemical structure of the copper chelator trientine (triethylene tetramine dihydrochloride, short name triene) differs from penicillamine. Trientine has usually been used as an alternative or substitute for penicillamine, in particular when penicillamine's major side effects are not tolerable (Walshe 1982). Triene only rarely has side effects. Similar to penicillamine long-term treatment with trientine may cause hepatic iron accumulation in persons with WD. Trientine is poorly absorbed from the gastrointestinal tract, and only 1% appears in the urine (Walshe 1982). Doses range from 750 to 1500 mg/d given in 2 or 3 divided doses; 750 or 1000 mg are given for maintenance therapy (Roberts 2003). In children a dose of 20 mg/kg/d is recommended. Similar to penicillamine, trientine should be given 1 hour before or 2 hours after meals. The effectiveness of copper chelation by triene is measured as described for penicillamine. Triene chelates several metals such as copper, zinc, and iron by urinary excretion and it effectively removes accumulated copper from various organs in persons with WD as well as in severe liver disease (Walshe 1979, Scheinberg 1987, Santos 1996, Saito 1991). It is still unclear whether penicillamine is a more effective copper chelator when compared to triene; probably the difference in effectiveness is small (Walshe 1973, Sarkar 1977). Potential deterioration of neurological disease may also be seen after starting triene therapy; the worsening however is less frequent and less pronounced than that seen after starting with penicillamine.

**Zinc.** Most physicians substitute penicillamine or triene with zinc for maintenance therapy when most copper accumulation has been removed. Zinc can also be given as initial therapy in asymptomatic patients diagnosed by family screening. A recent report however shows that WD symptoms may occur despite zinc prophylaxis in asymptomatic patients (Mishra 2008). In a recent study from India, 45 WD patients were on both penicillamine and zinc sulfate. The majority of patients (84%) had neuropsychiatric manifestations. The mean duration of treatment with penicillamine and zinc, before stopping penicillamine, was 107 months. All patients had to stop penicillamine due to the financial burden. The patients then only

received zinc sulfate for 27 months and 44 of the 45 patients (98%) remained stable. Only one patient reported worsening in dysarthria (Sinha 2008). Zinc does not act as an iron chelator but inhibits intestinal copper absorption and has also been suggested to bind free toxic copper (Brewer 1983, Schilksky 1989, Hill 1987). Zinc rarely has any side effects. It is still unclear whether zinc as monotherapy is an effective “decoppering” agent in symptomatic patients. There are some hints that hepatic copper may accumulate despite zinc therapy including reports about hepatic deterioration with a fatal outcome (Lang 1993, Walshe 1995). Therefore some authors use zinc in combination with a chelator. Neurological deterioration is rather rare under zinc therapy (Brewer 1987, Czlonkowska 1996). The recommended doses of zinc vary in the literature: according to AASLD practice guidelines dosing is in milligrams of elemental zinc (Roberts 2003). For larger children and adults, 150 mg/d is administered in 3 divided doses. Compliance with doses given thrice daily may be problematic; zinc has to be taken at least twice daily to be effective (Brewer 1998). Other authors recommend using zinc sulfate at 150 mg thrice daily as a loading dose and 100 mg thrice daily for maintenance. Further recommendations suggest giving 50 mg as zinc acetate thrice daily in adults. The type of zinc salt used has been thought to make no difference with respect to efficacy (Roberts 2003). However, zinc acetate has been suggested to cause the least gastrointestinal discomfort. When zinc is combined with a chelator the substances should be given at widely spaced intervals, potentially causing compliance problems. Effectiveness of the zinc treatment should be checked as described for penicillamine and zinc (Roberts 2003).

**Tetrathiomolybdate.** Tetrathiomolybdate is an experimental copper chelator not approved by FDA or EMA. It has been suggested as the initial treatment of WD patients with neurological involvement. Early reports say that tetrathiomolybdate stabilizes the neurological disease and reduces circulating free copper in a matter of weeks (Brewer 1994, Brewer 1996). A more recent randomized study supports this view and also suggests that zinc monotherapy is insufficient for treatment of neurological WD (Brewer 2006).

**Vitamin E, other antioxidants and diet.** Since serum and hepatic concentrations of vitamin E levels may be reduced in WD (von Herbay 1994, Sokol 1994) it has been suggested to complement vitamin E intake. Some authors have also recommended taking other antioxidants; studies have not proven their effectiveness as yet.

WD patients should avoid food with high copper content (nuts, chocolate, shellfish, mushrooms, organ meats, etc). Patients living in older buildings should also check whether the water runs through copper pipes. Such dietary and lifestyle restrictions do not replace chelator or zinc therapy (Roberts 2003).

**Fulminant hepatic failure and LTX.** Most WD patients with fulminant liver failure need LTX urgently in order to survive (Sokol 1985, Roberts 2003). However, in a long-term cohort study only two patients died prior to LTX being available (Stremmel 1991). It is a difficult clinical question whether WD patients with liver failure can survive without LTX. The prognostic score used to help with this difficult decision includes bilirubin, AST, and INR (Nazer 1986). In any case, WD patients with signs of fulminant liver failure need to be transferred immediately (same day!) to a transplant center.

WD patients with a chronic course of decompensated cirrhosis follow the usual rules for LTX. LTX cures the metabolic defects and thus copper metabolism returns to normal afterwards (Groth 1973). Prognosis for WD after LTX is excellent, in particular when patients survive the first year (Eghtesad 1999). It is still unclear under which circumstances LTX may be helpful for WD patients with neurological complications, which do not respond to drug therapy. In some patients CNS symptoms regress after LTX while other patients do not improve (for literature see Brewer 2000).

**Asymptomatic Patients.** All asymptomatic WD subjects - usually identified by family screening - need to be treated by chelators or zinc in order to prevent life-threatening complications (Walshe 1988, Brewer 1989, Roberts 2003). It is unclear whether therapy should begin in children under the age of 3 years.

**Maintenance Therapy.** After initial removal of excessive copper by chelators, some centres replace the chelators with zinc for maintenance therapy. It is unclear when such change is advisable and whether it might be better to reduce the dose of chelators instead of replacing them with zinc. It is generally accepted that replacement of chelators with zinc should only be done in patients who are clinically stable for some years, have normal aminotransferase and liver function, a normal free copper concentration and a 24-hr urinary copper repeatedly in the range of 200-500  $\mu\text{g}$  while on chelators (Roberts 2003). Long-term treatment with zinc may be associated with fewer side effects than chelator treatment. Many patients on trientine, however, do have significant side effects, and this author believes one does need to replace trientine with zinc in such patients. In any case, therapy either with a chelator or with zinc needs to be maintained indefinitely; any interruption may lead to lethal liver failure (Walshe 1986, Scheinberg 1987).

**Pregnancy.** Treatment must be maintained during pregnancy because an interruption has been shown to carry a high risk of fulminant liver failure (Shimono 1991). Maintenance therapy with chelators (penicillamine, trientine) or with zinc usually results in a good outcome for mother and child, although birth defects have (rarely) been documented [for literature see Sternlieb 2000]. It is recommended that the doses of both chelators be reduced, if possible by about 50%, in particular during the last trimester to avoid potential problems in wound healing (Roberts 2003). Zinc does not need to be reduced.

## Monitoring of treatment

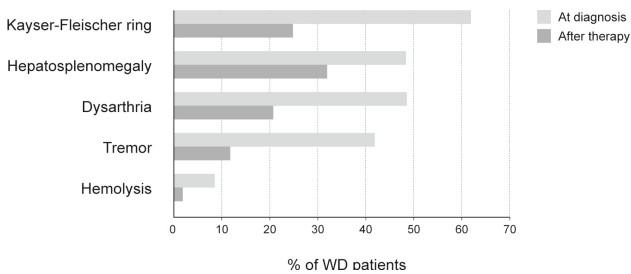
Monitoring should be done closely during initial treatment in all WD patients to look for efficacy (Figure 6) and side effects. During the maintenance phase patients should be checked at least twice a year.

**Table 2. Monitoring the treatment efficacy in WD.**

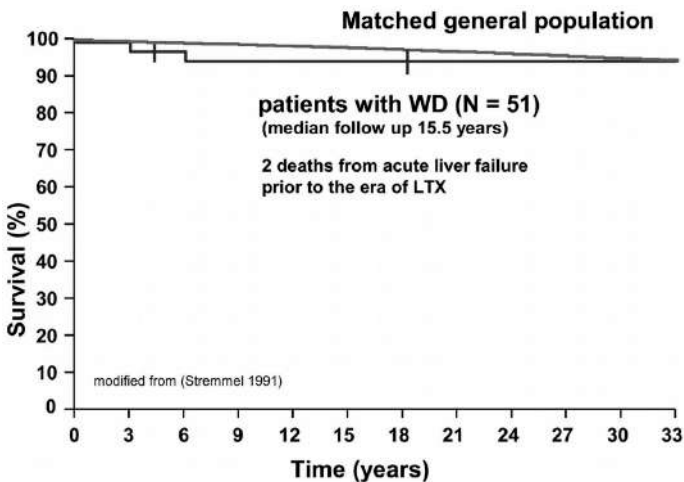
Clinical Improvement (Neurologic features, liver disease, hematology)
Regression of Kayser-Fleischer Ring
Circulating free copper <10 $\mu\text{l/dl}$
24-hr urinary copper excretion (200-500 $\mu\text{g/day}$ on chelators)
Decrease in liver copper content

Clinical examinations include neurological, ophthalmologic and psychiatric consultations (Figure 7). Patients with liver involvement need to be checked carefully for signs of liver failure.

Laboratory tests include measurements of serum copper and ceruloplasmin, calculation of free (nonceruloplasmin-bound) copper (see above), and 24-hr urinary copper excretion (Roberts 2003). While on chelating therapy 24-hr urinary copper excretion should initially range between 200 and 500  $\mu\text{g}$ ; such a value can also suggest that the patient is adherent to the drug. After removal of copper accumulation, urinary copper excretion may be lower. Prognosis of WD is dependent on the initial severity of the disease and then on adherence to the life-long treatment. Patients treated prior to severe and potentially irreversible neurological and hepatic complications have a good prognosis approaching a normal life expectancy (Figure 8). Irreversible liver disease often can be treated successfully by LTX while some patients with severe neurological disease do not get better despite optimal therapy.



**Figure 5. Findings prior to and after beginning chelating therapy in 53 WD patients** (modified from Stremmel 1991).



**Figure 6. Cumulative survival in 51 WD patients versus a matched general population** (modified from Stremmel 1991).



## References

- Aisen AM, Martel W, Gabrielsen TO, et al. Wilson disease of the brain: MR imaging. *Radiology* 1985;157:137-41. ([Abstract](#))
- Azizi E, Eshel G, Aladjem M. Hypercalciuria and nephrolithiasis as a presenting sign in Wilson disease. *Eur J Pediatr* 1989;148:548-9. ([Abstract](#))
- Bergstrom RF, Kay DR, Harkcom TM, Wagner JG. Penicillamine kinetics in normal subjects. *Clin Pharmacol Ther* 1981;30:404-13. ([Abstract](#))
- Berman DH, Leventhal RI, Gavaler JS, Cadoff EM, Van Thiel DH. Clinical differentiation of fulminant Wilsonian hepatitis from other causes of hepatic failure. *Gastroenterology* 1991;100:1129-34. ([Abstract](#))
- Brewer GJ, Hill GM, Prasad AS, Cossack ZT, Rabbani P. Oral zinc therapy for Wilson's disease. *Ann Intern Med* 1983;99:314-9. ([Abstract](#))
- Brewer GJ, Terry CA, Aisen AM, Hill GM. Worsening of neurologic syndrome in patients with Wilson's disease with initial penicillamine therapy. *Arch Neurol* 1987;44:490-3. ([Abstract](#))
- Brewer GJ, Yuzbasiyan-Gurkan V, Young AB. Treatment of Wilson's disease. *Semin Neurol* 1987;7:209-20. ([Abstract](#))
- Brewer GJ, Yuzbasiyan-Gurkan V, Lee DY, Appelman H. Treatment of Wilson's disease with zinc. VI. Initial treatment studies. *J Lab Clin Med* 1989;114:633-8. ([Abstract](#))
- Brewer GJ, Dick RD, Johnson V, et al. Treatment of Wilson's disease with ammonium tetrathiomolybdate. I. Initial therapy in 17 neurologically affected patients. *Arch Neurol* 1994;51:545-54. ([Abstract](#))
- Brewer GJ, Johnson V, Dick RD, Kluin KJ, Fink JK, Brunberg JA. Treatment of Wilson disease with ammonium tetrathiomolybdate. II. Initial therapy in 33 neurologically affected patients and follow-up with zinc therapy. *Arch Neurol* 1996;53:1017-25. ([Abstract](#))
- Brewer GJ, Dick RD, Johnson VD, Brunberg JA, Kluin KJ, Fink JK. Treatment of Wilson's disease with zinc: XV long-term follow-up studies. *J Lab Clin Med* 1998;132:264-78. ([Abstract](#))
- Brewer GJ, Askari F. Transplant livers in Wilson's disease for hepatic, not neurologic, indications. *Liver Transpl* 2000;6:662-4. ([Abstract](#))
- Brewer GJ, Askari F, Lorincz MT, et al. Treatment of Wilson disease with ammonium tetrathiomolybdate. IV. Comparison of tetrathiomolybdate and trientine in a double-blind study of treatment of the neurologic presentation of Wilson disease. *Arch Neurol* 2006;63:521-7 ([Abstract](#))
- Bull PC, Thomas GR, Rommens JM, Forbes JR, Cox DW. The Wilson disease gene is a putative copper transporting P-type ATPase similar to the Menkes gene. *Nat Genet* 1993;5:327-37. ([Abstract](#))
- Cairns JE, Williams HP, Walshe JM. "Sunflower cataract" in Wilson's disease. *Br Med J* 1969;3:95-6. ([Abstract](#))
- Cauza E, Maier-Dobersberger T, Polli C, Kaserer K, Kramer L, Ferenci P. Screening for Wilson's disease in patients with liver diseases by serum ceruloplasmin. *J Hepatol* 1997;27:358-62. ([Abstract](#))
- Chu CC, Huang CC, Chu NS. Recurrent hypokalemic muscle weakness as an initial manifestation of Wilson's disease. *Nephron* 1996;73:477-9. ([Abstract](#))
- Cummings JN. The effect of BAL in hepatolenticular degeneration. *Brain* 1951;74:10-22. ([Abstract](#))
- Czlonkowska A, Gajda J, Rodo M. Effects of long-term treatment in Wilson's disease with D-penicillamine and zinc sulphate. *J Neurol* 1996; 243:269-73. ([Abstract](#))
- Denny-Brown D, Porter H. The effect of BAL (2,3 dimercaptopropanol) on hepatolenticular degeneration (Wilson's disease). *N Engl J Med* 1951;245:917-25.
- Eghtesad B, Nezakatgoo N, Geraci LC, et al. Liver transplantation for Wilson's disease: a single-center experience. *Liver Transpl Surg* 1999;5:467-74. ([Abstract](#))
- Emre S, Atillasoy EO, Ozdemir S, et al. Orthotopic liver transplantation for Wilson's disease: a single-center experience. *Transplantation* 2001;72:1232-6. ([Abstract](#))
- Ferenci P, Czlonkowska A, Merle U, et al. Late-onset Wilson's disease. *Gastroenterology* 2007;132:1294-8. ([Abstract](#))
- Ferlan-Marolt V, Stepec S. Fulminant Wilsonian hepatitis unmasked by disease progression: report of a case and review of the literature. *Dig Dis Sci* 1999;44:1054-8. ([Abstract](#))

## 450 Hepatology 2012

- Fleischer B. Ueber einer der "Pseudosklerose" nahestehende bisher unbekannte Krankheit (gekennzeichnet durch Tremor, psychische Störungen, braunliche Pigmentierung bestimmter Gewebe, insbesondere der Hornhautperipherie, Lebercirrhose). *Deutsch Z Nerven Heilk* 1912;44:179-201.
- Frommer DJ. Urinary copper excretion and hepatic copper concentrations in liver disease. *Digestion* 1981;21:169-78. (Abstract)
- Frydman M. Genetic aspects of Wilson's disease. *J Gastroenterol Hepatol* 1990;5:483-90. (Abstract)
- Geller SA, Petrovic LM, Batts KB, et al. Histopathology of end-stage Wilson disease. *Mod Pathol* 2000; 13:184A.
- Giacchino R, Marazzi MG, Barabino A, et al. Syndromic variability of Wilson's disease in children. Clinical study of 44 cases. *Ital J Gastroenterol Hepatol* 1997;29:155-61. (Abstract)
- Grand RJ, Vawter GF. Juvenile Wilson disease: histologic and functional studies during penicillamine therapy. *J Pediatr* 1975;87:1161-70. (Abstract)
- Gross JB, Jr., Ludwig J, Wiesner RH, McCall JT, LaRusso NF. Abnormalities in tests of copper metabolism in primary sclerosing cholangitis. *Gastroenterology* 1985;89:272-8. (Abstract)
- Groth CG, Dubois RS, Corman J, et al. Metabolic effects of hepatic replacement in Wilson's disease. *Transplant Proc* 1973;5:829-33. (Abstract)
- Gow PJ, Smallwood RA, Angus PW, Smith AL, Wall AJ, Sewell RB. Diagnosis of Wilson's disease: an experience over three decades. *Gut* 2000;46:415-9. (Abstract)
- Harris ZL, Klomp LW, Gitlin JD. Aceruloplasminemia: an inherited neurodegenerative disease with impairment of iron homeostasis. *Am J Clin Nutr* 1998;67:972S-977S. (Abstract)
- Hill GM, Brewer GJ, Prasad AS, Hydrick CR, Hartmann DE. Treatment of Wilson's disease with zinc. I. Oral zinc therapy regimens. *Hepatology* 1987;7:522-8. (Abstract)
- Kalach N, Seidman EG, Morin C, et al. Acute liver failure from Wilson's disease in a five year-old child. *Can J Gastroenterol* 1993;7:610-2.
- Lang CJ, Rabas-Kolominsky P, Engelhardt A, Kobras G, König HJ. Fatal deterioration of Wilson's disease after institution of oral zinc therapy. *Arch Neurol* 1993;50:1007-8. (Abstract)
- Lau JY, Lai CL, Wu PC, Pan HY, Lin HJ, Todd D. Wilson's disease: 35 years' experience. *Q J Med* 1990;75:597-605. (Abstract)
- Loudianos G, Figus AL, Loi A, et al. Improvement of prenatal diagnosis of Wilson disease using microsatellite markers. *Prenat Diagn* 1994;14:999-1002. (Abstract)
- Martins da Costa C, Baldwin D, Portmann B, Lolin Y, Mowat AP, Mieli-Vergani G. Value of urinary copper excretion after penicillamine challenge in the diagnosis of Wilson's disease. *Hepatology* 1992;15: 609-15. (Abstract)
- Menkes JH. Menkes disease and Wilson disease: two sides of the same copper coin. Part I: Menkes disease. *Europ J Paediatr Neurol* 1999;3: 147-58.
- Merle U, Schaefer M, Ferenci P, Stremmel W. Clinical presentation, diagnosis and long-term outcome of Wilson's disease: a cohort study. *Gut* 2007;56:115-20. (Abstract)
- Milkiewicz P, Saksena S, Hubscher SG, Elias E. Wilson's disease with superimposed autoimmune features: report of two cases and review. *J Gastroenterol Hepatol* 2000;15:570-4. (Abstract)
- Mishra D, Kalra V, Seth R. Failure of prophylactic zinc in Wilson disease. *Indian Pediatr* 2008;45:151-3 (Abstract)
- Nakada SY, Brown MR, Rabinowitz R. Wilson's disease presenting as symptomatic urolithiasis: a case report and review of the literature. *J Urol* 1994;152:978-9. (Abstract)
- Nazer H, Ede RJ, Mowat AP, Williams R. Wilson's disease: clinical presentation and use of prognostic index. *Gut* 1986;27:1377-81. (Abstract)
- Petrukhin K, Fischer SG, Pirastu M, et al. Mapping, cloning and genetic characterization of the region containing the Wilson disease gene. *Nat Genet* 1993;5:338-43. (Abstract)
- Rector WG, Uchida T, Kanel GC, Redeker AG, Reynolds TB. Fulminant hepatic and renal failure complicating Wilson's disease. *Liver* 1984;4:341-7. (Abstract)
- Roberts EA, Cox DW. Wilson disease. *Baillieres Clin Gastroenterol* 1998;12:237-56. (Abstract)
- Roberts EA, Schilsky ML. A Practice Guideline on Wilson Disease. *Hepatology* 2003;37:1475-92. (Abstract)
- Saito T. Presenting symptoms and natural history of Wilson disease. *Eur J Pediatr* 1987;146:261-5. (Abstract)

- Saito H, Watanabe K, Sahara M, Mochizuki R, Edo K, Ohyama Y. Triethylene-tetramine (trien) therapy for Wilson's disease. *Tohoku J Exp Med* 1991;164:29-35. (Abstract)
- Sallie R, Katsiyiannakis L, Baldwin D, et al. Failure of simple biochemical indexes to reliably differentiate fulminant Wilson's disease from other causes of fulminant liver failure. *Hepatology* 1992;16:1206-11. (Abstract)
- Santos Silva EE, Sarles J, Buts JP, Sokal EM. Successful medical treatment of severely decompensated Wilson disease. *J Pediatr* 1996;128:285-7. (Abstract)
- Sarkar B, Sass-Kortsak A, Clarke R, Laurie SH, Wei P. A comparative study of in vitro and in vivo interaction of D-penicillamine and triethylene-tetramine with copper. *Proc R Soc Med* 1977;70:13-8. (Abstract)
- Scheinberg IH, Gitlin D. Deficiency of ceruloplasmin in patients with hepatolenticular degeneration (Wilson's disease). *Science* 1952;116:484-5. (Abstract)
- Scheinberg IH, Jaffe ME, Sternlieb I. The use of trientine in preventing the effects of interrupting penicillamine therapy in Wilson's disease. *N Engl J Med* 1987;317:209-13. (Abstract)
- Schilsky M, Blank RR, Czaja MJ, Scheinberg IH, Stockert RJ, Sternlieb I. Hepatocellular copper toxicity and its attenuation by zinc. *J Clin Invest* 1989;84:1562-8. (Abstract)
- Schilsky ML, Scheinberg IH, Sternlieb I. Prognosis of Wilsonian chronic active hepatitis. *Gastroenterology* 1991;100:762-7. (Abstract)
- Schilsky ML, Scheinberg IH, Sternlieb I. Liver transplantation for Wilson's disease: indications and outcome. *Hepatology* 1994;19:583-7. (Abstract)
- Scott J, Gollan JL, Samourian S, Sherlock S. Wilson's disease, presenting as chronic active hepatitis. *Gastroenterology* 1978;74:645-51. (Abstract)
- Shah AB, Chernov I, Zhang HT, et al. Identification and analysis of mutations in the Wilson disease gene (ATP7B): population frequencies, genotype-phenotype correlation, and functional analyses. *Am J Hum Genet* 1997;61:317-28. (Abstract)
- Shimono N, Ishibashi H, Ikematsu H, et al. Fulminant hepatic failure during perinatal period in a pregnant woman with Wilson's disease. *Gastroenterol Jpn* 1991;26:69-73. (Abstract)
- Sinha S, Taly AB. Withdrawal of penicillamine from zinc sulphate-penicillamine maintenance therapy in Wilson's disease: promising, safe and cheap. *J Neurol Sci* 2008;264:129-32 (Abstract)
- Sokol RJ, Francis PD, Gold SH, Ford DM, Lum GM, Ambruso DR. Orthotopic liver transplantation for acute fulminant Wilson disease. *J Pediatr* 1985;107:549-52. (Abstract)
- Sokol RJ, Twedt D, McKim JM, et al. Oxidant injury to hepatic mitochondria in patients with Wilson's disease and Bedlington terriers with copper toxicosis. *Gastroenterology* 1994;107:1788-98. (Abstract)
- Song YM, Chen MD. A single determination of liver copper concentration may misdiagnose Wilson's disease. *Clin Biochem* 2000;33:589-90. (Abstract)
- Steindl P, Ferenci P, Dienes HP, Grimm G, Pabinger I, Madl C, et al. Wilson's disease in patients presenting with liver disease: a diagnostic challenge. *Gastroenterology* 1997;113:212-218. (Abstract)
- Sternlieb I. Copper and the liver. *Gastroenterology* 1980;78:1615-28. (Abstract)
- Sternlieb I. Perspectives on Wilson's disease. *Hepatology* 1990;12:1234-9. (Abstract)
- Sternlieb I. Wilson's disease and pregnancy. *Hepatology* 2000;31:531-2. (Abstract)
- Stremmel W, Meyerrose KW, Niederau C, Hefter H, Kreuzpaintner G, Strohmeyer G. Wilson disease: clinical presentation, treatment, and survival. *Ann Intern Med* 1991;115:720-6. (Abstract)
- Tanzi RE, Petrukhin K, Chernov I, et al. The Wilson disease gene is a copper transporting ATPase with homology to the Menkes disease gene. *Nat Genet* 1993;5:344-50. (Abstract)
- Tauber J, Steinert RF. Pseudo-Kayser-Fleischer ring of the cornea associated with non-Wilsonian liver disease. A case report and literature review. *Cornea* 1993;12:74-7. (Abstract)
- Thomas GR, Roberts EA, Walshe JM, Cox DW. Haplotypes and mutations in Wilson disease. *Am J Hum Genet* 1995;56:1315-9. (Abstract)
- Tu JB, Blackwell RQ. Studies on levels of penicillamine-induced cupriuresis in heterozygotes of Wilson's disease. *Metabolism* 1967;16:507-13. (Abstract)
- van Wassenaeer-van Hall HN, van den Heuvel AG, Algra A, Hoogenraad TU, Mali WP. Wilson disease: findings at MR imaging and CT of the brain with clinical correlation. *Radiology* 1996;198:531-6. (Abstract)

- von Herbay A, de Groot H, Hegi U, Stremmel W, Strohmeyer G, Sies H. Low vitamin E content in plasma of patients with alcoholic liver disease, hemochromatosis and Wilson's disease. *J Hepatol* 1994;20:41-6. ([Abstract](#))
- Walshe JM. Wilson's disease. New oral therapy. *Lancet* 1956;i:25-6. ([Abstract](#))
- Walshe JM. Copper chelation in patients with Wilson's disease. A comparison of penicillamine and triethylene tetramine dihydrochloride. *Q J Med* 1973;42:441-52. ([Abstract](#))
- Walshe JM. The management of Wilson's disease with triethylene tetramine 2HC1 (Trien 2HC1). *Prog Clin Biol Res* 1979;34:271-80. ([Abstract](#))
- Walshe JM. Treatment of Wilson's disease with trientine (triethylenetetramine) dihydrochloride. *Lancet* 1982;1:643-7.
- Walshe JM, Dixon AK. Dangers of non-compliance in Wilson's disease. *Lancet* 1986;1:845-7. ([Abstract](#))
- Walshe JM. Diagnosis and treatment of presymptomatic Wilson's disease. *Lancet* 1988;2:435-7. ([Abstract](#))
- Walshe JM. Wilson's disease presenting with features of hepatic dysfunction: a clinical analysis of eighty-seven patients. *Q J Med* 1989;70:253-63. ([Abstract](#))
- Walshe JM, Yealland M. Chelation treatment of neurological Wilson's disease. *Q J Med* 1993;86:197-204. ([Abstract](#))
- Walshe JM, Munro NA. Zinc-induced deterioration in Wilson's disease aborted by treatment with penicillamine, dimercaprol, and a novel zero copper diet. *Arch Neurol* 1995;52:10-1. ([Abstract](#))
- Wilson SAK. Progressive lenticular degeneration: a familial nervous disease associated with cirrhosis of the liver. *Brain* 1912;34:295-507.
- Wilson DC, Phillips MJ, Cox DW, Roberts EA. Severe hepatic Wilson's disease in preschool-aged children. *J Pediatr* 2000;137:719-22. ([Abstract](#))
- Yamaguchi Y, Heiny ME, Gitlin JD. Isolation and characterization of a human liver cDNA as a candidate gene for Wilson disease. *Biochem Biophys Res Commun* 1993;197:271-7. ([Abstract](#))

## 27. Autoimmune Liver Diseases: AIH, PBC and PSC

*Christian P. Strassburg*

### **Autoimmune hepatitis (AIH)**

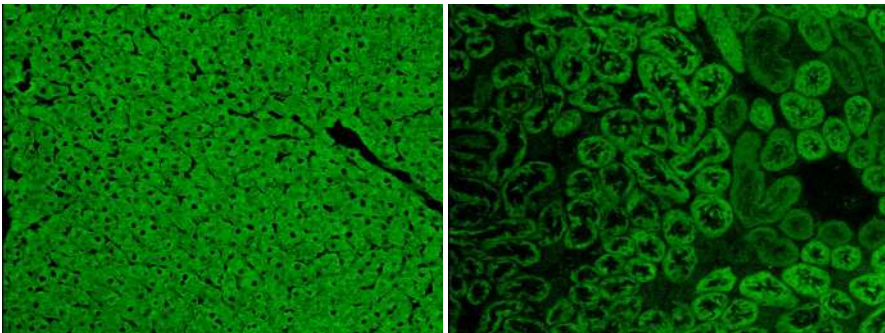
Autoimmune hepatitis (AIH) is a chronic inflammatory disease, in which a loss of tolerance against hepatic tissue is presumed. Autoimmune hepatitis (AIH) was first described as a form of chronic hepatitis in young women showing jaundice, elevated gamma globulins and amenorrhea, which eventually led to liver cirrhosis (Waldenström 1950). He also first described a beneficial effect of steroids in the patient cohort he reported on and thereby laid the groundwork for the first chronic liver disease found to be curable by drug therapy. AIH was later recognized in combination with other extrahepatic autoimmune syndromes, and the presence of antinuclear antibodies (ANA) led to the term lupoid hepatitis (Mackay 1956). Systematic evaluations of the cellular and molecular immunopathology, of the clinical symptoms and of laboratory features has subsequently led to the establishment of autoimmune hepatitis as a separate clinical entity which is serologically heterogeneous, treated by a specific therapeutic strategy (Strassburg 2000). An established (Alvarez 1999a) and recently simplified (Hennes 2008b) revised scoring system allows for a reproducible and standardized approach to diagnosing AIH in a scientific context. The use and interpretation of seroimmunological and molecular biological tests permits a precise discrimination of autoimmune hepatitis from other etiologies of chronic hepatitis, in particular from chronic viral infection as the most common cause of chronic hepatitis worldwide (Strassburg 2002). Today, AIH is a treatable chronic liver disease in the majority of cases. Much of the same initial treatment strategies of immunosuppression still represent the standard of care. The largest challenge regarding treatment is the timely establishment of the correct diagnosis.

### **Definition and diagnosis of autoimmune hepatitis**

In 1992, an international panel met in Brighton, UK, to establish diagnostic criteria for AIH, because it was recognized that several features including histological changes and clinical presentation are also prevalent in other chronic liver disorders (Johnson 1993). In this and in a revised report the group noted that there is no single

test for the diagnosis of AIH. In contrast, a set of diagnostic criteria was suggested in the form of a diagnostic scoring system designed to classify patients as having probable or definite AIH (Table 1). According to this approach the diagnosis relies on a combination of indicative features of AIH and the exclusion of other causes of chronic liver diseases. AIH predominantly affects women at any age, and is characterized by a marked elevation of serum globulins, in particular gammaglobulins, and circulating autoantibodies. It should be noted that AIH regularly affects individuals older than 40 but should be considered in all age groups (Strassburg 2006). The clinical appearance ranges from an absence of symptoms to a severe or fulminant presentation (Stravitz 2011) and responds to immunosuppressive treatment in most cases. An association with extrahepatic autoimmune diseases such as rheumatoid arthritis, autoimmune thyroiditis, ulcerative colitis and diabetes mellitus and a family history of autoimmune or allergic disorders has been reported (Strassburg 1995).

Autoantibodies are one of the distinguishing features of AIH. The discovery of autoantibodies directed against different cellular targets including endoplasmatic reticulum membrane proteins, nuclear antigens and cytosolic antigens has led to a suggested subclassification of AIH based upon the presence of 3 specific autoantibody profiles. According to this approach, AIH type 1 is characterized by the presence of antinuclear antibodies (ANA) and/or anti-smooth muscle antibodies (SMA) directed predominantly against smooth muscle actin. AIH type 2 is characterized by anti liver-kidney microsomal autoantibodies (LKM-1) directed against cytochrome P450 CYP2D6 (Manns 1989, Manns 1991) (Figure 1) and with lower frequency against UDP-glucuronosyltransferases (UGT) (Strassburg 1996). AIH type 3 (Manns 1987, Stechemesser 1993) is characterized by autoantibodies against a soluble liver antigen (SLA/LP) identified as UGA suppressor serine tRNA-protein complex (Gelpi 1992, Wies 2000, Volkmann 2001, Volkmann 2010). However, this serological heterogeneity does not influence the decision of whom to treat or of what strategy to employ.



**Figure 1: Indirect immunofluorescence showing LKM-1 autoantibodies on rat kidney and liver cryostat sections.** Serum of a patient with autoimmune hepatitis type 2. A. Using rat hepatic cryostat sections a homogeneous cellular immunofluorescence staining is visualized excluding the hepatocellular nuclei (LKM-1). B. Typical indirect immunofluorescence pattern of LKM-1 autoantibodies detecting the proximal (cortical) renal tubules but excluding the distal tubules located in the renal medulla, which corresponds to the tissue expression pattern of the autoantigen CYP2D6.

Although the histological appearance of AIH is characteristic, there is no specific histological feature that can be used to prove the diagnosis (Dienes 1989). Percutaneous liver biopsy should be performed for grading and staging, as well as for therapeutic monitoring. Histological features usually include periportal hepatitis with lymphocytic infiltrates, plasma cells, and piecemeal necrosis. With advancing disease, bridging necrosis, panlobular and multilobular necrosis may occur and ultimately lead to cirrhosis. A lobular hepatitis can be present, but is only indicative of AIH in the absence of copper deposits or biliary inflammation. In addition, granulomas and iron deposits argue against AIH. A liver biopsy should be obtained at first diagnosis before therapy for grading, staging and as confirmation of the diagnosis.

Viral hepatitis should be excluded by the use of reliable, commercially available tests. The exclusion of ongoing hepatitis A, B and C virus infection is sufficient in most cases. The exclusion of other hepatotropic viruses such as cytomegalovirus, Epstein-Barr and herpes group may only be required in cases suspicious of such infections or if the diagnosis of AIH based on the above-mentioned criteria remains inconclusive.

The probability of AIH decreases whenever signs of bile duct involvement are present, such as elevation of alkaline phosphatase, histological signs of cholangiopathy and detection of AMA. If one or more components of the scoring system are not evaluated, merely a score pointing to a probable diagnosis can be compiled (Table 1).

## Epidemiology and clinical presentation

Based on limited epidemiological data, the prevalence is estimated to range between 50 and 200 cases per 1 million in Western Europe and North America among the Caucasian population. The prevalence of AIH is similar to that of systemic lupus erythematosus, primary biliary cirrhosis and myasthenia gravis, which also have an autoimmune etiology (Nishioka 1997, Nishioka 1998). Among the North American and Western European Caucasian population AIH accounts for up to 20% of cases with chronic hepatitis (Cancado 2000). However, chronic viral hepatitis remains the major cause of chronic hepatitis in most Western societies. In locales in which viral hepatitis B and C are endemic, such as in Asia and Africa, the incidence of AIH appears to be significantly lower. Additional epidemiological analyses are required to comprehensively elucidate the prevalence and geographical distribution of AIH.

Autoimmune hepatitis is part of the syndrome of chronic hepatitis, which is characterized by sustained hepatocellular inflammation of at least 6 months duration and elevation of ALT and AST of 1.5 times the upper normal limit. In about 49% of AIH patients an acute onset of AIH is observed and rare cases of fulminant AIH have been reported. In most cases, however, the clinical presentation is not spectacular and characterized by fatigue, right upper quadrant pain, jaundice and occasionally also by palmar erythema and spider naevi. In later stages, the consequences of portal hypertension dominate, including ascites, bleeding esophageal varices and encephalopathy. A specific feature of AIH is the association of extrahepatic immune-mediated syndromes including autoimmune thyroiditis, vitiligo, alopecia, nail dystrophy, ulcerative colitis, rheumatoid arthritis, and also diabetes mellitus and glomerulonephritis.

**Table 1. International criteria for the diagnosis of autoimmune hepatitis (Alvarez 1999).**

Parameter	Score
<b>Gender</b>	
Female	+2
Male	0
<b>Serum biochemistry</b>	
Ratio of elevation of serum alkaline phosphatase vs aminotransferase	
>3.0	-2
1.5-3	0
<1.5	+2
<b>Total serum globulin, <math>\gamma</math>-globulin or IgG</b> (times upper limit of normal)	
>2.0	+3
1.5-2.0	+2
1.0-1.5	+1
<1.0	0
<b>Autoantibodies</b> (titers by immunofluorescence on rodent tissues)	
Adults	
<b>ANA, SMA or LKM-1</b>	
>1:80	+3
1:80	+2
1:40	+1
<1:40	0
<b>Antimitochondrial antibody</b>	
Positive	-4
Negative	0
<b>Hepatitis viral markers</b>	
negative	+3
positive	-3
<b>History of drug use</b>	
Yes	-4
No	+1
<b>Alcohol (average consumption)</b>	
<25 gm/day	+2
>60 gm/day	-2
<b>Genetic factors: HLA-DR3 or -DR4</b>	+1
<b>Other autoimmune diseases</b>	+2
<b>Response to therapy</b>	
complete	+2
relapse	+3
<b>Liver histology</b>	
interface hepatitis	+3
predominant lymphoplasmacytic infiltrate	+1
rosetting of liver cells	+1
none of the above	-5
biliary changes	-3
other changes	-3
<b>Seropositivity for other defined autoantibodies</b>	+2

**Interpretation of aggregate scores:** definite AIH - greater than 15 before treatment and greater than 17 after treatment; probable AIH - 10 to 15 before treatment and 12 to 17 after treatment.



## Natural history and prognosis

Data describing the natural history of AIH are scarce. The last placebo-controlled immunosuppressive treatment trial containing an untreated arm was published in 1980 (Kirk 1980). The value of these studies is limited considering that these patients were only screened for epidemiological risk factors for viral hepatitis and were not characterized by standardized diagnostic criteria and available virological tests. Nevertheless, these studies reveal that untreated AIH had a very poor prognosis and 5- and 10-year survival rates of 50% and 10% were reported. They furthermore demonstrated that immunosuppressive treatment significantly improved survival.

Data reveal that up to 30% of adult patients had histological features of cirrhosis at diagnosis. In 17% of patients with periportal hepatitis cirrhosis developed within 5 years, but cirrhosis develops in 82% when bridging necrosis or necrosis of multiple lobules is present. The frequency of remission (86%) and treatment failure (14%) are comparable in patients with and without cirrhosis at presentation. Importantly, the presence of cirrhosis does not influence 10-year survival and those patients require a similarly aggressive treatment strategy (Geall 1968, Soloway 1972).

Almost half of the children with AIH already have cirrhosis at the time of diagnosis. Long-term follow-up revealed that few children can completely stop all treatment and about 70% of children receive long-term treatment (Homborg 1987, Gregorio 1997). Most of these patients relapse when treatment is discontinued, or if the dose of the immunosuppressive drug is reduced. About 15% of patients develop chronic liver failure and are transplanted before the age of 18 years.

In elderly patients, a more severe initial histological grade has been reported (Strassburg 2006). The risk of hepatocellular carcinoma varies considerably between the different diseases PBC, PSC and AIH. Particular PCS can be complicated by cholangiocarcinoma, gall bladder carcinoma and hepatocellular carcinoma. In contrast, occurrence of HCC in patients with AIH is a rare event and develops only in long-standing cirrhosis.

## Who requires treatment?

Autoimmune hepatitis (AIH) is a remarkably treatable chronic liver disease (Manns 2001, Czaja 2010). Untreated, the prognosis of active AIH is dismal with 5- and 10-year survival rates between 50 and 10% and a well recognized therapeutic effect exemplified by the last placebo-controlled treatment trials (Soloway 1972, Kirk 1980). For these reasons the indication for treatment is given in any patient who has an established diagnosis of AIH, elevations of aminotransferase activities (ALT, AST), an elevation of serum immunoglobulin G and histological evidence of interface hepatitis or necroinflammatory activity. This has recently been discussed in the newest version of the AIH guidelines for the American Association for the Study of the Liver (AASLD) (Manns 2010a). These points indicate that an initial liver biopsy specimen is desirable for confirmation of the diagnosis and for grading and staging. Biopsies are also helpful for observation of aminotransferase activities in serum reflecting inflammatory activity in the liver, which is not closely correlated in all cases.

## Who does not require treatment?

Only very few patients with an established diagnosis of AIH should not be treated. Rare cases, in which the initiation of standard therapy should be weighed against potential side effects, are contraindications with steroids or azathioprine, or for certain other immunosuppressants (see below). In decompensated liver cirrhosis of patients on the waiting list for liver transplantation and in individuals with complete cirrhosis and absent inflammatory activity treatment does not appear beneficial (Manns 2010a).

## Standard treatment strategy

Independent of clinically- or immunoserologically-defined type of AIH, standard treatment is implemented with predniso(lo)ne alone or in combination with azathioprine. Both strategies are just as effective (Manns 2001, Manns 2010a). The basic strategy of this treatment is still based upon the findings of studies of almost 3 decades ago that indicated the effectiveness of steroids in AIH. Since that time no single multicenter randomized treatment trial in AIH patients has been performed. All advances of alternative treatment strategies are based on small cohorts and on the need to develop strategies for difficult-to-treat patients. The use of prednisone or its metabolite prednisolone, which is used more frequently in European countries, is equally effective since chronic liver disease does not seem to have an effect on the synthesis of prednisolone from prednisone. Important is the exact differentiation between viral infection and autoimmune hepatitis. Treatment of replicative viral hepatitis with corticosteroids must be prevented as well as administration of interferon in AIH, which can lead to dramatic disease exacerbation.

Standard induction treatment and suggested follow-up examinations are summarized in Table 2. Please note that there are differences in preferred regimen in Europe and the US, which are delineated in the AASLD AIH Guideline (Manns 2010a). Therapy is usually administered over the course of 2 years. The decision between monotherapy and combination therapy is guided principally by side effects. Long-term steroid therapy leads to cushingoid side effects. Cosmetic side effects decrease patient compliance considerably (Table 3). Serious complications such as steroid diabetes, osteopenia, aseptic bone necrosis, psychiatric symptoms, hypertension and cataract formation also have to be anticipated in long-term treatment. Side effects are present in 44% of patients after 12 months and in 80% of patients after 24 months of treatment. However, predniso(lo)ne monotherapy is possible in pregnant patients. Azathioprine, on the other hand, leads to a decreased dose of prednisone. It bears a theoretical risk of teratogenicity. In addition, abdominal discomfort, nausea, cholestatic hepatitis, rashes and leukopenia can be encountered. These side effects are seen in 10% of patients receiving a dose of 50 mg per day. From a general point of view, a postmenopausal woman with osteoporosis, hypertension and elevated blood glucose would be a candidate for combination therapy. In young women, pregnant women or patients with hematological abnormalities, prednisone monotherapy may be the treatment of choice.

**Table 2. Treatment regimen and follow-up examinations of autoimmune hepatitis regardless of autoantibody type.**

	Monotherapy		Combination therapy			
Prednis(ol)one	60 mg reduction by 10 mg/week to maintenance of 20 mg/wk reduction by 5 mg to 10 mg find lowest dose in 2.5 mg decrements		30-60 mg reduction as in monotherapy			
Azathioprine	n.a. (maintenance with azathioprine: monotherapy: 2 mg/kg body weight)		1 mg/kg of body weight (Europe) 50 mg (US)			

Examination	Before therapy	During therapy before remission q 4 weeks	Remission on therapy q 3-6 months	Cessation of therapy q 3 weeks (x 4)	Remission post-therapy relapse q 3-6 months	Evaluation of
Physical	+		+	+	+	+
Liver biopsy	+		(+/-)			+
Blood count	+	+	+	+	+	
Aminotransferases	+	+	+	+	+	+
Gamma glutamyltransferase	+	+	+			
Gammaglobulin	+	+	+	+	+	+
Bilirubin	+	+	+	+	+	+
Coagulation studies	+	+	+	+	+	
Autoantibodies	+	+/-				+
Thyroid function tests	+	+/-				+

**Table 3. Side effects.**

Prednis(ol)one	acne moon-shaped face striae rubra dorsal hump obesity weight gain diabetes mellitus cataracts hypertension
Azathioprine	nausea vomiting abdominal discomforts hepatotoxicity rash leukocytopenia teratogenicity (?) oncogenicity (?)

One of the most important variables for treatment success is adherence. The administration of treatment is essential since most cases of relapse are the result of erratic changes of medication and/or dose. Dose reduction is aimed at finding the individually appropriate maintenance dose. Since histology lags 3 to 6 months behind the normalization of serum parameters, therapy has to be continued beyond the normalization of aminotransferase levels. Usually, maintenance doses of predniso(lo)ne range between 10 and 2.5 mg. After 12-24 months of therapy predniso(lo)ne can be tapered over the course of 4-6 weeks to test whether a sustained remission has been achieved. Tapering regimens aiming at withdrawal should be attempted with great caution and only after obtaining a liver biopsy that demonstrates a complete resolution of inflammatory activity. Relapse of AIH and risk of progression to fibrosis is almost universal when immunosuppression is tapered in the presence of residual histological inflammation. Withdrawal should be attempted with caution to prevent recurrence and subsequent fibrosis progression and should be discussed with the patient and closely monitored.

Outcomes of standard therapy can be classified into four categories: remission, relapse, treatment failure and stabilization.

**Remission** is a complete normalization of all inflammatory parameters including histology. This is ideally the goal of all treatment regimens and ensures the best prognosis. Remission can be achieved in 65-75% of patients after 24 months of treatment. Remission can be sustained with azathioprine monotherapy of 2 mg/kg bodyweight (Johnson 1995). This prevents cushingoid side effects. However, side effects such as arthralgia (53%), myalgia (14%), lymphopenia (57%) and myelosuppression (6%) have been observed. Complete remission is not achieved in about 20% of patients and these patients continue to carry a risk of progressive liver injury.

**Relapse** is characterized by an increase in aminotransferase levels and the recurrence of clinical symptoms either while on treatment, following tapering of steroid doses to determine the minimally required dose, or, after a complete withdrawal of therapy. Relapse can be found in 50% of patients within 6 months of treatment withdrawal and in 80% after 3 years. Relapse is associated with progression to cirrhosis in 38% and liver failure in 14%. Relapse requires reinitiation of standard therapy, consideration of dosing as well as diagnosis, and perhaps a long-term maintenance dose with predniso(lo)ne or azathioprine monotherapy.

**Treatment failure** characterizes a progression of clinical, serological and histological parameters during standard therapy. This is seen in about 10% of patients. In these cases the diagnosis of AIH has to be carefully reconsidered to exclude other etiologies of chronic hepatitis. In these patients experimental regimens can be administered or ultimately liver transplantation becomes necessary.

**Stabilization** is the achievement of a partial remission. Since 90% of patients reach remission within 3 years, the benefit of standard therapy has to be reevaluated in this subgroup of patients. Ultimately, liver transplantation provides a definitive treatment option.

## Treatment of elderly patients

The presentation of acute hepatitis, clinical symptoms of jaundice, abdominal pain and malaise have a high likelihood of attracting medical attention and subsequently leading to the diagnosis of AIH (Nikias 1994). More subtle courses of AIH may not lead to clinically relevant signs and may develop unnoticed other than via routine work-up for other problems or via screening programs. The question of disease onset in terms of initiation of immune-mediated liver disease versus the clinical consequences that become noticeable after an unknown period of disease progression is not easily resolved. Thus, "late onset" AIH may just simply reflect a less severe course of the disease with a slower progression to cirrhosis. While LKM-positive patients display a tendency towards an earlier presentation, both acute and subtle (earlier and late presentation) variants appear to exist in ANA-positive AIH. In practice, the diagnostic dilemma is that AIH is still perceived by many as a disease of younger individuals and that therefore this differential diagnosis is less frequently considered in elderly patients with "cryptogenic" hepatitis or cirrhosis. Another relevant question resulting from these considerations is the issue of treatment. Standard therapy in AIH consists of steroids alone or a combination with azathioprine. In maintenance therapy azathioprine monotherapy can also be administered but induction with azathioprine alone is not effective. From a general standpoint most internists will use caution when administering steroids to elderly patients, especially in women in whom osteopenia or diabetes may be present.

Recommendations for the treatment of AIH suggest that the steroid side effects be weighed against the potential benefit of therapy, and that not all patients with AIH are good candidates for steroid treatment (Manns 2001). Controversy exists surrounding the benefit of therapy in this group of elderly patients. One cohort reported on 12 patients over 65 out of a total of 54 AIH patients. Cirrhosis developed after follow-up in 26% irrespective of age although the histological grade of AIH activity was more severe in the elderly group. 42% of the patients over 65 did not receive therapy and yet deaths were reported only in the younger group (Newton 1997). In another cohort of 20 patients aged >65 years, a longer time to establishment of the diagnosis (8.5 vs. 3.5 months) was reported, patients presented mainly with jaundice and acute onset AIH and showed a response rate to immunosuppression comparable to that of younger patients (Schramm 2001). The authors also noted that the prevalence of the HLA-A1-B8 allotype was less frequent in older patients suggesting a role for immunogenetics.

This point was further elaborated by a recent report analyzing 47 patients with ANA-positive AIH 60 years and older, as well as 31 patients 30 years and younger in whom DR4+/DR3- prevalence was 47% (older) versus 13% (younger) patients (Czaja 2006). In the older patients steroid responsiveness was better, which is in line with previous findings in the same collective (Czaja 1993). Cirrhosis and extrahepatic immune-mediated syndromes including thyroid and rheumatologic disease (47% vs. 26%) were more prevalent in older AIH patients. However, although more treatment failures were observed in the younger patients (24% vs 5%) the rates of remission, sustained remission and relapse were similar. Interestingly, an assessment of age-stratified prevalence showed an increase after the age of 40 from 15% to over 20%.

From all this data, AIH in elderly patients appears to be characterized by a distinct clinical feature, a distinct immunogenetic profile, favourable response rates and higher rates of cirrhosis present at diagnosis, all of which contribute to the heterogeneity of AIH. In a cohort of 164 patients from the UK including 43 individuals 60 years and older AIH was looked at (Al-Chalabi 2006). The age groups showed no significant differences regarding serum biochemistry, autoantibody titers, time to establishment of diagnosis, and mode of presentation. The authors provided a substratification of patients below and above 40 years of age and reported that older patients had a higher median histological stage and a comparable median grade but younger patients had more median relapse episodes and a higher median stage at follow-up biopsy. The most distinguishing clinical sign was a higher prevalence of ascites in the older group. However, rates of complete, partial and failed response were similar, and the median number of relapses was higher in younger patients, which nevertheless did not lead to differences in liver-related deaths in either group (12% vs. 15%). In comparison to the study of ANA-positive AIH patients from the US (Czaja 2006) the differing findings regarding HLA association are noteworthy. In the UK study there was no differential distribution of HLA-DR3 and -DR4 and this questions the suggested hypothesis of a primary influence of immunogenetics on the observed clinical distinctions. The reasons for the clinical differences of AIH in older and younger patients are unclear. They may include differences in hepatic blood flow and alterations involving the regulation of cellular immunity during aging (Talor 1991, Prelog 2006). In summary, these data suggest that AIH in elderly patients should be considered and treated (Strassburg 2006).

## Alternative Treatments

When standard treatment fails or drug intolerance occurs, alternative therapies such as cyclosporin, tacrolimus, cyclophosphamide, mycophenolate mofetil, rapamycin, UDCA, and budesonide can be considered (Table 4). The efficacy of most of these options has not yet been definitively decided and is only reported in small case studies.

**Table 4. Alternative drugs in autoimmune hepatitis.**

Compound	Advantage	Disadvantage
Budesonide	High first pass effect Immunosuppressive action Inactive metabolites	Cirrhosis (portosystemic shunts) and side effects
Cyclosporine	Satisfactory experience Potent immunosuppressant Transplant immunosuppressant	Renal toxicity
Tacrolimus	Potent immunosuppressant Transplant immunosuppressant	Renal toxicity
Mycophenolic acid	Favourable toxicity profile Transplant immunosuppressant	Disappointing effectiveness
Cyclophosphamide	Effective	Continuous therapy Hematological side effects

## Budesonide

Budesonide is a synthetic steroid with high first-pass metabolism in the liver, in principle with limited systemic side effects compared to conventional steroids. In comparison to prednisone the absolute bioavailability of budesonide is less than 6-fold lower (Thalen 1979) but it has an almost 90% first-pass metabolism in the liver, a higher affinity to the glucocorticoid receptor, acts as an anti-inflammatory and immunosuppressive drug and leads to inactive metabolites (6-OH-budesonide, 16-OH-prednisolone). In a pilot study treating 13 AIH patients with budesonide over a period of 9 months the drug was well tolerated and aminotransferase levels were normalized (Danielson 1994). However, in a second study budesonide therapy was associated with a low frequency of remission and high occurrence of side effects (Czaja 2000). In that study, 10 patients were treated who had previously been treated with azathioprine and steroids and had not reached a satisfactory remission. The conclusion of the authors was that budesonide was not a good treatment option in those patients. A third study with 12 previously untreated patients was published (Wiegand 2005). In this study remission was induced with budesonide combination therapy. The authors performed kinetic analyses and reported that in those with high inflammatory activity and cirrhosis the area under the curve (AUC) of budesonide was increased. This finding plausibly demonstrates that in patients with portosystemic shunts in portal hypertension the effect of high hepatic first-pass metabolism that would limit typical steroid side effects is reduced.

The main advantage of budesonide for the future treatment of autoimmune hepatitis would therefore be to replace prednisone in long-term maintenance therapy and induction therapy to reduce steroid side effects. To this end the first multicenter placebo-controlled randomised AIH treatment trial in 3 decades was performed with a total of 207 non-cirrhotic patients from 30 centres in 9 European countries and Israel (Manns 2010b). In this trial 40 mg prednisone (reduction regimen) and azathioprine was compared to 3 mg budesonide (TID initially, reduced to BID) in combination with azathioprine. The data was recently published and shows that budesonide in combination with azathioprine is efficient in inducing stable remission, is superior in comparison to a standard prednisone tapering regimen beginning with 40 mg per day (Manns 2010b) and leads to a substantially superior profile of steroid-specific side effects. From these data budesonide is emerging as an alternative first-line treatment strategy for non-cirrhotic patients with AIH (Manns 2010b).

## Deflazacort

This alternative corticosteroid has also been studied for immunosuppression in AIH because of its feature of fewer side effects than conventional glucocorticoids. In a pilot study 15 patients with AIH type I were treated with deflazacort, who had been previously treated with prednisone with or without azathioprine until they reached a biochemical remission. Remission was sustained for 2 years of follow-up. However, the long-term role of second-generation corticosteroids to sustain remission in AIH patients with reduced treatment related side effects requires further controlled studies (Rebollo Bernardez 1999).

## Cyclosporine A

Cyclosporine A (CyA) is a lipophilic cyclic peptide of 11 residues produced by *Tolypocladium inflatum* that acts on calcium-dependent signaling and inhibits T cell function via the interleukin 2 gene (Strassburg 2008). Out of the alternative AIH drugs considerable experience has been reported with CyA. In these studies CyA was successfully used for AIH treatment and was well tolerated (Alvarez 1999b, Debray 1999). The principal difficulty in advocating widespread use of CyA as first-line therapy relates to its toxicity profile, particularly with long-term use (increased risk of hypertension, renal insufficiency, hyperlipidemia, hirsutism, infection, and malignancy) (Alvarez 1999b, Debray 1999, Fernandez 1999, Heneghan 2002).

## Tacrolimus

Tacrolimus is a macrolide lactone compound with immunosuppressive qualities exceeding those of CyA. The mechanism of action is similar to that of CyA but it binds to a different immunophilin (Strassburg 2008). The application of tacrolimus in 21 patients treated for 1 year led to an improvement of aminotransferase and bilirubin levels with a minor increase in serum BUN and creatinine levels (Van Thiel 1995). In a second study with 11 steroid refractory patients improvement of inflammation was also observed (Aqel 2004). Although tacrolimus represents a promising immunosuppressive candidate drug, larger randomized trials are required to assess its role in the therapy of AIH.

## Mycophenolic acid

Mycophenolate has attracted attention as a transplant immunosuppressant with an important role in the steroid-free immunosuppressive therapy of patients transplanted for chronic hepatitis C infection. Mycophenolate is a noncompetitive inhibitor of inosine monophosphate dehydrogenase, which blocks the rate-limiting enzymatic step in *de novo* purine synthesis. Mycophenolate has a selective action on lymphocyte activation, with marked reduction of both T and B lymphocyte proliferation. In a pilot study 7 patients with AIH type 1 who either did not tolerate azathioprine or did not respond to standard therapy with a complete normalization of aminotransferase levels were treated with mycophenolate in addition to steroids. In 5 out of 7 patients normalization of aminotransferase levels was achieved within 3 months. These preliminary data suggested that mycophenolate may represent a promising treatment strategy of AIH (Richardson 2000). In a recent retrospective study 37 patients with AIH and azathioprine failure or intolerance were treated with mycophenolate (Hennes 2008a). There was no statistically significant benefit for mycophenolate treatment. Less than 50% reached remission and in the azathioprine non-responders failure was 75%. Although the toxicity profile of mycophenolate would suggest its use, the retrospective study data does not indicate an effective second line therapeutic option.

## Cyclophosphamide

The induction of remission with 1-1.5 mg per kg per day of cyclophosphamide in combination with steroids has been reported. However the dependency of continued application of cyclophosphamide with its potentially severe hematological side effects renders it a highly experimental treatment option (Kanzler 1996).



## Anti-TNF $\alpha$ antibodies

There is some emerging evidence that anti-TNF antibodies are capable of inducing remission in AIH patients in whom standard or alternative therapeutic options have been exhausted (Efe 2010, Umekita 2011). However, the development of AIH has also been observed under treatment with anti-TNF antibodies (Ramos-Casals 2008). Future studies will have to define the role of this therapeutic option in difficult-to-treat cases of AIH.

## Ursodeoxycholic acid

Ursodeoxycholic acid is a hydrophilic bile acid with putative immunomodulatory capabilities. It is presumed to alter HLA class I antigen expression on cellular surfaces and to suppress immunoglobulin production. Uncontrolled trials have shown a reduction in histological abnormalities, clinical and biochemical improvement but not a reduction of fibrosis in 4 patients with AIH type 1 (Calmus 1990, Nakamura 1998, Czaja 1999). However, its role in AIH therapy or in combination with immunosuppressive therapy is still unclear.

Other alternative treatment strategies include methotrexate, anti-TNF  $\alpha$  antibodies, and rituximab, but there is currently insufficient data on any of these.

## Overlap syndromes and treatment

The term overlap syndrome describes a disease condition that is only incompletely defined (Strassburg 2006). A valid definition is difficult (Boberg 2011). It is characterized by the coexistence of clinical, biochemical or serological features of autoimmune hepatitis (AIH), primary biliary cirrhosis (PBC), primary sclerosing cholangitis (PSC), and depending on the definition, also viral hepatitis C (Ben-Ari 1993, Colombato 1994, Duclos-Vallee 1995, Chazouilleres 1998, Angulo 2001, Rust 2008). In adult patients an overlap of PBC and AIH is most frequently encountered although it is unclear whether this is true co-existence of both diseases or an immunoserological overlap characterized by the presence of antinuclear (ANA) as well as antimitochondrial (AMA) antibodies (Poupon 2006, Gossard 2007, Silveira 2007, Al-Chalabi 2008). In many AMA-negative patients with a cholestatic liver enzyme profile ANA are present. This has been termed autoimmune cholangiopathy or AMA-negative PBC (Mchieletti 1994).

Apart from coexisting, autoimmune liver diseases can also develop into each other, i.e., the sequential manifestation of PBC and autoimmune hepatitis. The true coexistence of AIH and PSC has only been conclusively shown in pediatric patients (Gregorio 2001). It can be hypothesized whether a general predisposition toward liver autoimmunity exists which has a cholestatic, a hepatic and a bile duct facet, which may be variable depending upon unknown host factors. The diagnosis of an overlap syndrome relies on the biochemical profile (either cholestatic with elevated alkaline phosphatase, gamma glutamyltransferase and bilirubin, or hepatic with elevated aspartate aminotransferase and alanine aminotransferase levels in addition to elevated gamma globulins), the histology showing portal inflammation with or without the involvement of bile ducts, and the autoantibody profile showing AMA or autoantibodies associated primarily with AIH such as liver-kidney microsomal

antibodies (LKM), soluble liver antigen antibodies (SLA) or ANA. In cholestatic cases cholangiography detects sclerosing cholangitis. In an overlap syndrome the classical appearance of the individual disease component is mixed with features of another autoimmune liver disease. Immunoglobulins are usually elevated in all autoimmune liver diseases.

Regarding a therapeutic strategy the leading disease component is treated. In an overlap syndrome presenting as hepatitis, immunosuppression with prednisone (or combination therapy with azathioprine) is initiated. In cholestatic disease ursodeoxycholic acid is administered. Both treatments can be combined when biochemistry and histology suggest a relevant additional disease component (Chazouilleres 1998). Validated therapeutic guidelines for overlap syndromes are not available. It is important to realize that treatment failure in AIH may be related to an incorrect diagnosis or an overlap syndrome of autoimmune liver diseases (Potthoff 2007). Several studies show that treatment of the AIH component of overlapping syndromes is important to avoid progression to cirrhosis (Chazouilleres 2006, Gossard 2007, Silveira 2007, Al-Chalabi 2008).

## Liver transplantation

In approximately 10% of AIH patients liver transplantation remains the only life-saving option (Strassburg 2004). The indication for liver transplantation in AIH is similar to that in other chronic liver diseases and includes clinical deterioration, development of cirrhosis, bleeding esophageal varices and coagulation abnormalities despite adequate immunosuppressive therapy (Neuberger 1984, Sanchez-Urdazpal 1991, Ahmed 1997, Prados 1998, Tillmann 1999, Vogel 2004). There is no single indicator or predictor for the necessity of liver transplantation. Candidates for liver transplant are usually patients who do not reach remission within 4 years of continuous therapy. Indicators of a high mortality associated with liver failure are histological evidence of multilobular necrosis and progressive hyperbilirubinemia. In Europe, 4% of liver transplants are for AIH (Strassburg 2009). The long-term results of liver transplantation for AIH are excellent. The 5-year survival is up to 92% (Sanchez-Urdazpal 1991, Prados 1998, Ratziu 1999) and well within the range of other indications for liver transplantation. The European liver transplant database indicates 76% survival in 5 years and 66% survival after 10 years (1647 liver transplantations between 1988 and 2007). When these numbers are considered it is necessary to realize that patients undergoing liver transplantation usually fail standard therapy and may therefore have a reduced life expectancy after liver transplant compared to those who achieve stable complete remission on drug therapy.

## Recurrence and *de novo* AIH after liver transplantation

The potential of AIH to recur after liver transplantation is beyond serious debate (Schreuder 2009). The first case of recurrent AIH after liver transplant was reported in 1984 (Neuberger 1984), and was based upon serum biochemistry, biopsy findings and steroid reduction. Studies published over the years indicate that the rate of recurrence of AIH ranges between 10-35%, and that the risk of AIH recurrence is perhaps as high as 68% after 5 years of follow-up (Wright 1992, Devlin 1995, Götz 1999, Milkiewicz 1999, Manns 2000, Vogel 2004). It is important to consider the criteria upon which the diagnosis of recurrent AIH is based. When transaminitis is

chosen as a practical selection parameter many patients with mild histological evidence of recurrent AIH may be missed. It is therefore suggested that all patients with suspected recurrence of autoimmune hepatitis receive a liver biopsy, biochemical analyses of aminotransferases as well as a determination of immunoglobulins and autoantibody titers (Vogel 2004). Significant risk factors for the recurrence of AIH have not yet been identified although it appears that the presence of fulminant hepatic failure before transplantation protects against the development of recurrent disease. Risk factors under discussion include steroid withdrawal, tacrolimus versus cyclosporine, HLA mismatch, HLA type, and LKM-1 autoantibodies. An attractive risk factor for the development of recurrent AIH is the presence of specific HLA antigens that may predispose toward a more severe immunoreactivity. In two studies recurrence of AIH appeared to occur more frequently in HLA-DR3-positive patients receiving HLA-DR3-negative grafts. However, this association was not confirmed in all studies. There have not been conclusive data to support the hypothesis that a specific immunosuppressive regimen represents a risk factor for the development of recurrent AIH (Gautam 2006). However, data indicate that patients transplanted for AIH require continued steroids in 64% versus 17% of patients receiving liver transplants for other conditions (Milkiewicz 1999).

Based on these results and other studies it would appear that maintenance of steroid medication in AIH patients is indicated to prevent not only cellular rejection but also graft-threatening recurrence of AIH (Vogel 2004). Steroid withdrawal should therefore be performed only with great caution. The recurrence of AIH is an important factor for the probability of graft loss. Apart from hepatitis C and primary sclerosing cholangitis a recent report found AIH recurrence to represent the third most common reason for graft loss (Rowe 2008). Transplanted patients therefore require a close follow-up and possibly an immunosuppressive regimen including steroids, although this is controversial and not backed by prospective studies (Campsen 2008).

In addition to AIH recurrence the development of *de novo* autoimmune hepatitis after liver transplantation has been reported (Kerker 1998, Jones 1999a, Salcedo 2002). The pathophysiology of this is also elusive. From a treatment point of view *de novo* autoimmune hepatitis, which appears to occur mostly in patients transplanted with PBC but may just be the serendipitous occurrence of AIH, is responsive to steroid treatment (Salcedo 2002).

## Primary biliary cirrhosis

### Introduction

Primary biliary cirrhosis (PBC) is a chronic inflammatory, cholestatic disease of the liver with an unknown cause. The clinical observation of a broad array of immune-mediated symptoms and phenomena suggests the disease to be of autoimmune etiology, in the course of which progressive and irreversible destruction of small interlobular and septal bile ducts progressively and irreversibly ensues (Table 5). As in other autoimmune diseases PBC affects women in over 80% of cases and is associated with varying extrahepatic autoimmune syndromes in up to 84%. These extrahepatic manifestations of immune-mediated disease include the dry gland syndrome (sicca syndrome with xerophthalmia and xerostomia) but also collagen

diseases, autoimmune thyroid disease, glomerulonephritis and ulcerative colitis (Table 6).

**Table 5. Clinical profile of primary biliary cirrhosis (PBC).**

Sex	90% female
Age	40-59 years
	pruritus
	jaundice
	skin pigmentation
Elevation	alkaline phosphatase (AP), aspartate aminotransferase (AST), bilirubin, IgM antimitochondrial antibodies (AMA) associated immune-mediated syndromes
Liver biopsy	- cellular bile duct infiltration - granulomas possible - copper deposits

**Table 6. Extrahepatic immune-mediated syndromes in PBC and overlap with rheumatic diseases.**

dry gland "sicca" syndrome
Sjögren's syndrome
rheumatoid arthritis
autoimmune thyroid disease
renal tubular acidosis
mixed connective tissue disease (MCTD)
polymyositis
polymyalgia rheumatica
pulmonary fibrosis
CREST syndrome
systemic lupus erythematosus (SLE)
pernicious anemia
ulcerative colitis
exogenous pancreatic insufficiency
myasthenia gravis

The striking female predominance (Donaldson 1996, Mackay 1997, Uibo 1999) and familiar clustering of PBC (Kato 1981, Jones 1999b, Tsuji 1999) suggest that inheritable genetic factors play a role in this disease. This has focussed attention on the immunogenetics of PBC in order to further define host risk factors (Manns 1994). Studies have suggested an instability of lymphocytic DNA in PBC patients (Notghi 1990). Immunogenetic analyses, however, have only come up with relatively weak associations with specific human leukocyte antigen haplotypes. An additional hypothesis is an alteration of bile acid composition and bile fluid composition, which would indicate a role for transporter proteins in the development of PBC. Bicarbonate rich bile is believed to be protective for biliary epithelium.

## Definition and prevalence of PBC

Primary biliary cirrhosis is an inflammatory, primarily T cell-mediated chronic destruction of intrahepatic microscopic bile ducts of unknown etiology (Strassburg 2000). It affects women in 80% of cases who exhibit elevated immunoglobulin M, antimitochondrial antibodies directed against the E2 subunit of pyruvate

dehydrogenase (PDH-E2), a cholestatic liver enzyme profile with elevated alkaline phosphatase, gamma glutamyltransferase as well as serum bilirubin levels, and a variable course of disease leading to cirrhosis over the course of years or decades. A prominent feature is the presence of extrahepatic immune-mediated disease associations. In later stages pronounced fatigue, pruritus, marked hyperbilirubinemia and the consequences of portal hypertension such as ascites, bleeding esophageal varices, and encephalopathy develop (Strassburg 2004).

The prevalence is estimated at 65 per 100,000 in women and 12 per 100,000 in men with an incidence of 5 per 100,000 in women and 1 per 100,000 in men. The prevalence and incidence appear to vary regionally. An increase of PBC incidence in recent years may be the result of more specific testing of antimitochondrial antibody reactivity (Strassburg 2004).

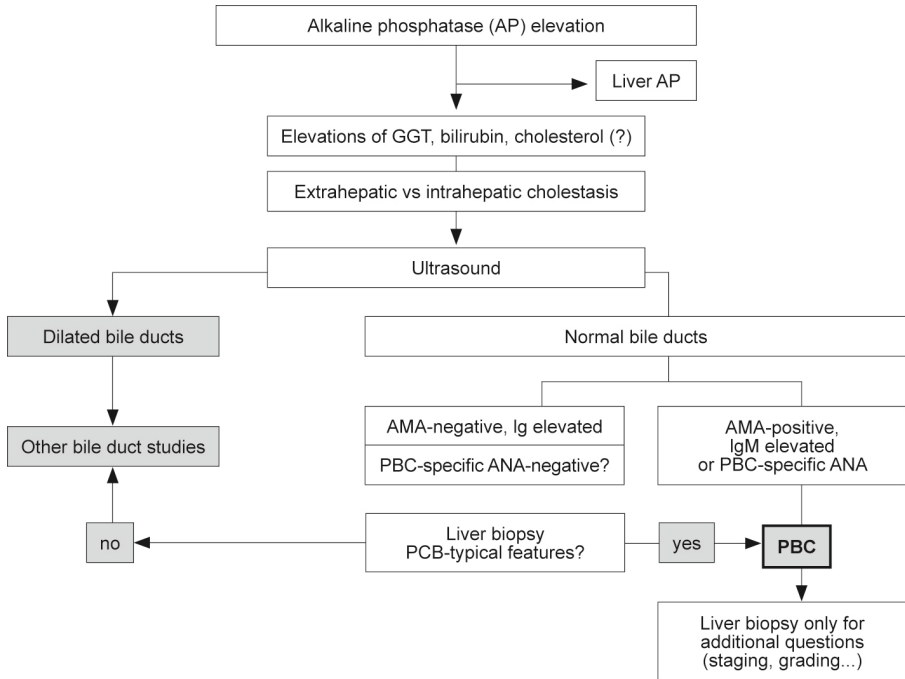
### **Diagnostic principles of PBC**

Suspicion of PBC arises when cholestasis and cirrhosis are present in middle-aged women (Figure 2). Ultrasound is employed to rule out mechanical cholestasis. The presence of antimitochondrial antibodies (AMA) against PDH-E2 is diagnostic of PBC. AMA against E2 subunits of members of the inner mitochondrial membrane-expressed oxoacid dehydrogenase complex (PDH, branched chain ketoacid dehydrogenase [BCKD], and ketoglutarate dehydrogenase [OADC]) are present in 95% of PBC patients. AMA-negative PBC can exhibit antinuclear autoantibodies with specificity against nuclear dot antigen (SP100), a 210 kDa nuclear membrane protein (gp210), or nucleoporin p62. In AMA-negative PBC a biopsy is indicated to contribute to the establishment of the diagnosis; in the presence of AMA against PDH-E2, histology is used primarily for the staging of cirrhosis and is not necessary (Strassburg 2004).

### **Diagnostic role of AMA in PBC**

The main aim of AMA determinations is the detection of PBC-specific AMA and the exclusion of AMA of low diagnostic relevance for the disease. As a screening test the determination of AMA using indirect immunofluorescence testing on rat kidney cryostat sections or immobilized Hep-2 cells (Strassburg 1999). The indirect immunofluorescence on rat kidney sections leads to the staining of the distal and proximal tubuli (note: proximal staining only is indicative of liver/kidney microsomal antibodies, LKM). When positive AMA immunofluorescence is detected, further analysis should include subclassification using molecularly defined antigen preparations. The detection of PDH-E2, BCKD-E2 can be achieved by ELISA using recombinant antigen or reference sera. If both are negative, testing should include OGD-E2. The final step is performed using Western Blot Analyses to confirm the findings. By Western Blot the indicative 74 kDa (PDH-E2), 52 kDa (BCKD-E2) and 48 kDa (OGD-E2) bands can be visualized. This multi-step regimen secures a rational and reliable diagnosis of PBC-specific AMA excluding those found in drug-induced and infectious diseases.

In the majority of cases the determination of anti-PDH-E2 is sufficient to secure the diagnosis. Studies will have to evaluate whether the future application of a single PDH-E2 ELISA as highly specific screening test in suspected PBC represents an efficient and economic diagnostic approach.



**Figure 2. Diagnostic algorithm of PBC including clinical presentation, ultrasound and serology.**

## Therapeutic principles in PBC

Treatment leading to a cure of PBC is not available (Strassburg 2004). Ursodeoxycholic acid (UDCA) (15 mg/kg body weight per day) has been shown to improve serum biochemistry, histology and survival but has no effect on fatigue and osteoporosis. It has immunomodulatory properties, alters cell signal transduction and modifies hydrophilicity of the bile. UDCA should not be given in severe cholestasis and during the first trimester of pregnancy. Immunosuppression in PBC has shown disappointing results. Symptomatic therapy of the complications of PBC includes management of pruritus (cholestyramine, induction with rifampicin, opioid antagonists, serotonin antagonists), ascites (diuretics, beta blockers to control portal hypertension), osteoporosis (vitamin D and calcium supplementation, bisphosphonates in some), as well as endoscopic intervention for bleeding esophageal varices. Fat-soluble vitamin replacement is suggested. When liver cirrhosis-induced liver failure is progressive liver transplantation remains a definitive therapeutic option. Ten-year survival rates are 75-80% and recurrence of PBC after transplant occurs in 10-40%. Recurrence can be expected in 25-30% (Rowe 2008, Strassburg 2009)

## Immunosuppression in PBC

**Corticosteroids:** Treatment with prednisolone can improve serum aminotransferase activities, alkaline phosphatase and elevated immunoglobulins. It does not lead to significant improvement of bilirubin, pruritus, or histology. In a

placebo-controlled study with 36 asymptomatic patients for over 1 year osteopenia and cushingoid side effects were noted (Mitchison 1992).

**Azathioprin:** The classical immunosuppressant azathioprin, which has a pronounced effect in AIH, did not show significant effects in two different studies and is not used in PBC (Christensen 1985).

**Cyclosporin A:** In a large study of 346 patients with a median observation time of 2.5 years this classical transplant immunosuppressant did not show significant effects on histological progression (Lombard 1993). Contrasting these findings, in a small study with 20 patients who were treated for 2 years, histology improved, which should however be viewed with caution (Wiesner 1990). Because of the possibility of severe side effects cyclosporin A is not a recommended therapeutic option.

**D-penicillamine:** Because PBC is characterized by copper accumulation in the bile ducts the chelator d-penicillamine was studied. D-penicillamine also has immunosuppressive and antifibrotic properties. It was tested on a total of 748 patients in 6 studies, without leading to a positive therapeutic effect. However, 30% of patients had severe side effects (Bodenheimer 1985). D-penicillamine in PBC is not recommended.

**Colchicine:** Because of its antifibrotic and anti-inflammatory properties colchicine was studied in 3 studies in the 1980s. Despite improvement of albumin, bilirubin, aminotransferases and alkaline phosphatase, an improvement of clinical symptoms and histology was not observed (Kaplan 1986, Warnes 1987, Bodenheimer 1988). Severe side effects were not reported but an effect on long-term prognosis was not seen.

**Methotrexate:** Despite its known hepatotoxicity, methotrexate was used as an immunosuppressant in PBC. In a placebo-controlled study with 60 patients, low-dose methotrexate (7.5 mg/week) led to an improvement of biochemical parameters except for bilirubin but no effects were reported regarding necessity of liver transplantation or survival (Hendrickse 1999). Hepatotoxicity was not observed. Interstitial pneumonitis, which affects 3-5% of rheumatoid arthritis patients, was observed in 14% of PBC patients. Methotrexate cannot be recommend outside of scientific evaluations or studies.

In principle other immunosuppressants (Table 7) such as mycophenolic acid (mycophenolate mofetil), tacrolimus (FK506) or even monoclonal antibodies against the interleukin 2 receptor may represent interesting candidate strategies. However, study data is currently lacking.

**Table 7. Effects of immunosuppressants in PBC.**

	Biochemical improvement	Histological improvement	Survival	Side effects/toxicity
Corticosteroids	++	++	-	++
Azathioprine	-	-	+	+
Cyclosporin A	++	-	++	++
D-penicillamine	-	-	-	++
Colchicine	++	-	+	-
Methotrexate	++	+	-	+

### Ursodeoxycholic acid in PBC (UDCA)

In 1981, a positive effect of UDCA was first observed on elevated liver parameters, the exact mechanism of which was unclear (Leuschner 1996). On one hand UDCA leads to a modification of the bile acid pool to a more hydrophilic environment with lower detergent-like properties, and it leads to increased bile flow. On the other hand an immunomodulatory activity is suggested regarding HLA antigens expressed on biliary epithelial cells and altered signal transduction (Paumgartner 2002). The optimal dose in PBC patients appears to be 13-15 mg/kg. In a meta-analysis of 3 studies that looked at 548 patients with this dose, biochemical improvement and a slower histological progression to fibrosis was observed (Poupon 1997). These effects were only evident when follow up extended to 4 years. These data rely heavily on the positive effects of a single study and it is not surprising that a subsequent meta-analysis of 8 studies with 1114 patients failed to find positive associations with UDCA therapy (Goulis 1999).

There are a number of problems with this. Doses varied and protocols included patients with insufficient dosing, and follow up was under 2 years in some cases. In a recently published analysis of 367 patients from 4 clinical cohorts an initiation of UDCA therapy in early stages of PBC (stage I-II) and a treatment duration of 2 years led to a retardation of histological progression, which argues for an early initiation of UDCA therapy after diagnosis even in the absence of fibrosis or cirrhosis. UDCA was also shown to improve biochemistry, delay portal hypertension and varices, and currently has no therapeutic alternative (Poupon 2003). No convincing effect was demonstrable on osteopenia and extrahepatic manifestations of PBC. An interesting side effect appears to be the significant reduction of colonic epithelial proliferation. UDCA therapy is not associated with a higher prevalence of colonic polyps and appears to delay their reappearance after polypectomy (Serfaty 2003).

### Therapy in non-responders and combination strategies

Non-response is usually defined as a failure to lower cholestatic enzyme activities or to reach normalisation of these parameters. In patients in whom alkaline phosphatase and gamma glutamyltransferase activities are not lowered by UDCA therapy, increased morbidity and progression is likely. Alternative therapeutic strategies can be considered.

**Steroids and UDCA:** The combination of immunosuppressants and UDCA was looked at in smaller studies and included the use of prednisolone (Leuschner 1996), azathioprine (Wolfhagen 1998) and budesonide (Leuschner 1999, Angulo 2000) (Table 7). In a randomised, controlled study with 30 patients, who received 10 mg prednisolone/day an improvement of inflammatory activity was reported (Leuschner 1996). A study with 9 mg budesonide/day showed in 39 patients not only biochemical but also histological improvement (Leuschner 1999). In an open study with 22 patients a deterioration of osteopenia was noted (Angulo 2000). The combination of budesonide and UDCA may have additional beneficial effects related to the activation of the anion exchanger AE2, which may serve to alter biliary composition and produce a more protective bicarbonate rich bile.

**Sulindac and UDCA:** In an open study with 23 patients and incomplete response to UDCA over 12 months treated with UDCA or UDCA and sulindac a trend



towards histological improvement and biochemical improvement were reported in the combination group (Leuschner 2002).

**Colchicine and UDCA:** In 3 studies the combination of colchicine and UDCA were studied for 24 months in a total of 118 patients (Raedsch 1992, Ikeda 1996, Poupon 1996). Although mild biochemical improvement was noted, the effect of longer treatment remains unclear. Because of the biliary elimination of colchicine combinations with bile acids, there may be potentially toxic effect.

**Methotrexate and UDCA:** Several pilot studies and 3 randomized studies have looked at methotrexate in combination with UDCA. In a recent randomized placebo-controlled protocol with 60 patients a high rate of side effects without therapeutic benefit was reported (Van Steenberg 1996, Bach 2003).

## Primary sclerosing cholangitis

### Diagnosis of primary sclerosing cholangitis (PSC)

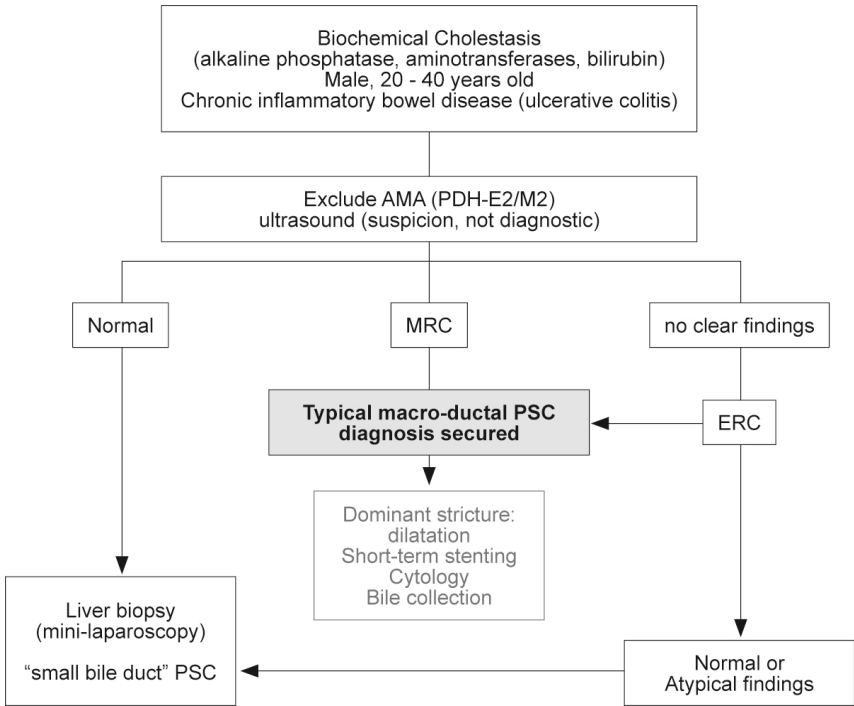
PSC is classically characterized by the progressive destruction of large intra- as well as extrahepatic bile ducts and – contrasting with AIH and PBC – preferentially affects male patients with a maximum age of around 25-45 (Strassburg 1996). About 50-75% of the time, PSC is associated with ulcerative colitis. PSC is clinically characterized by upper quadrant pain, pruritus, anorexia and fever, but up to 50% of patients lack any symptoms (Weismüller 2008). The diagnosis is established by a typical biochemical profile of cholestasis with elevations of bilirubin, alkaline phosphatase and gamma glutamyl transferase, the characteristic findings upon cholangiography and a typical biopsy showing ring fibrosis around the bile ducts, which is not present in all patients. Serology regularly identifies atypical anti-neutrophil cytoplasmic autoantibodies (xANCA) in up to 80% of patients (Terjung 2000), although these are not disease specific and can also occur in patients with ulcerative colitis without PSC. There is a significant association of PSC with cholangiocarcinoma (10-20%) and colorectal cancer (9% in 10 years). In a subgroup of patients, small bile duct PSC may be present (Broome 2002), which lacks typical strictures and pruning of the biliary tree upon cholangiography. In these cases the diagnosis can be established in the presence of the typical association with ulcerative colitis in male patients by performing a liver biopsy (Figure 3).

### Differential diagnosis: sclerosing cholangitis

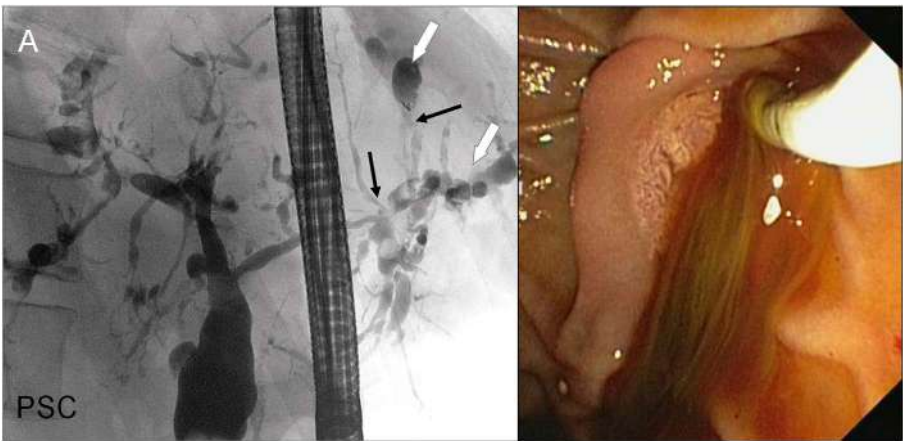
The finding of macroductal sclerosing cholangitis can be brought about by a number of conditions, which include ischemia, liver transplantation complications, and drugs. Of note are two additional differential diagnoses that require attention (Figure 4): secondary sclerosing cholangitis (Gelbmann 2007, Esposito 2008, von Figura 2009, Al-Benna 2011) and IgG4-associated cholangitis (Webster 2009, Clendenon 2011, Takuma 2011, Zhang 2011).

Secondary sclerosing cholangitis is an entity with severe infection of the biliary tree that develops in some patients following systemic infections and sepsis who are treated with aggressive intensive care unit management. IgG4-associated cholangitis is an immune-mediated entity often with high plasma levels of IgG4 and IgG4 expression in biliary cells obtained upon brush biopsy. The latter can be treated with

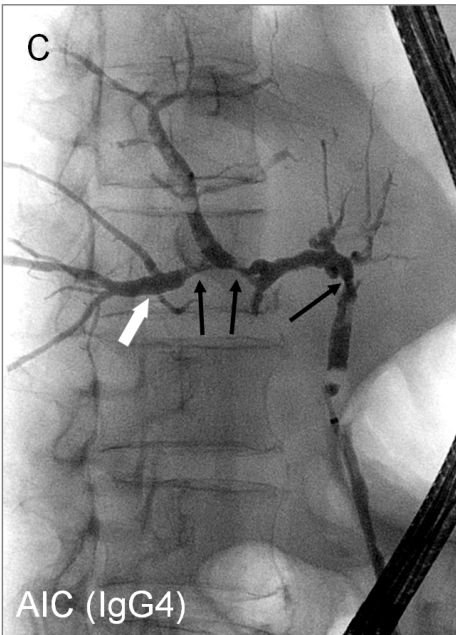
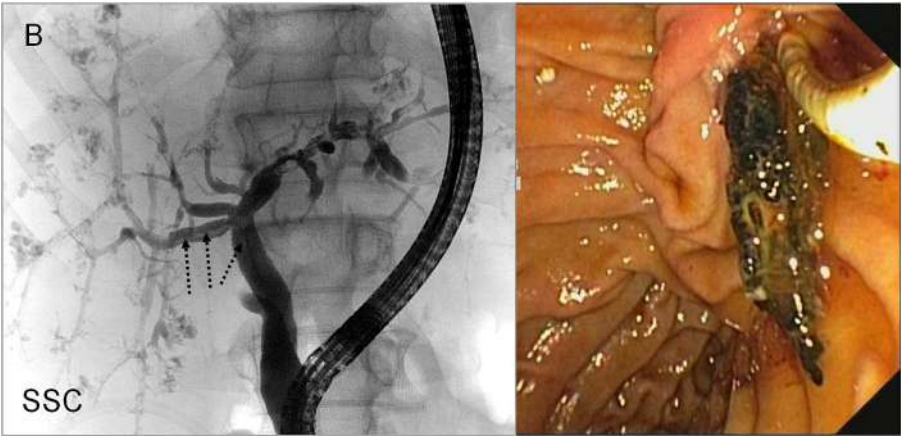
immunosuppression and should be diagnosed because of an available medical therapy.



**Figure 3. Diagnostic algorithm of PSC including clinical presentation.**



**Figure 4a. Examples of different entities of sclerosing cholangitis. A.** PSC showing multiple strictures with narrowing (black arrows) and prestenotic dilatation (white arrows) and an endoscopic aspect of purulent biliary infection at the biliary papilla.



**Figures 4b, 4c. Examples of different entities of sclerosing cholangitis.** B. Secondary sclerosing cholangitis (SSC) with a similar intrahepatic picture but also biliary casts (dotted arrows) that can be extracted endoscopically (right panel). C. Cholangiogram of autoimmune (AIC) IgG4-associated cholangitis mimicking PSC. Black arrows show narrowing, white arrows show dilations.

### Association of PSC with inflammatory bowel disease

A clinical hallmark of PSC is the high number of patients suffering from inflammatory bowel disease (IBD). In several studies with 605 PSC patients in the US (Mayo Clinic), UK (King's College) and in Sweden, IBD was found in 71%, 73% and 81% of PSC cases (Boberg 1998, Bergquist 2002). In our own experience

this is found in 52% of cases (Tischendorf 2007). Ulcerative colitis is more often associated (UK 71%, Sweden 72%) than Crohn's disease. IBD is usually diagnosed before PSC but owing to the symptomatic latency of both IBD and PSC it can also be diagnosed at the same time or later than PSC. Most commonly ulcerative colitis is diagnosed more than a year before PSC (67%). In 22% the diagnoses occurred within 1 year of each other, and only in 11% the was diagnosis of ulcerative colitis reached more than 1 year after PSC was established. IBD patients with elevated liver biochemistry are a risk group and require careful hepatological workup for PSC. About 5% of all patients with ulcerative colitis have PSC.

## PSC as a risk factor for cancer

Apart from the risk of developing portal hypertension and cirrhosis, PSC is a severe risk factor for cancer, which distinguishes this disease from AIH and PBC (Table 8). The increased risk of cholangiocarcinoma is well described (Bergquist 2001, Boberg 2002). The numbers reported vary because explanted livers during liver transplantation, autopsies and *in vivo* diagnosed cases are taken into account in different analyses. The diagnosis of cholangiocarcinoma (CC) in PSC patients continues to represent a difficult task because stenoses upon cholangiography may be caused by inflammatory activity as well as tumour, and because biochemical tests and biopsy procedures have a low sensitivity and specificity. Imaging studies are equally complicated by a lack of sensitivity since tumours frequently grow intramurally and are diagnosed in late stages precluding curative therapeutic approaches. Studies from Sweden show that 54% of CC occur within 1 year of the diagnosis of PSC and 27% are diagnosed at liver transplantation. Overall 12.2% of Northern European PSC patients develop CC, which is corroborated by our data from Hannover (Boberg 2002, Tischendorf 2006). These patients suffer from jaundice, pruritus and abdominal pains and had a longer IBD history. Male gender and smoking is also a risk factor (Tischendorf 2006, Weismüller 2008). In a Dutch study there were similar findings of 18 CC out of 174 patients (10%) (Ponsioen 2002). The CC risk of a PSC patient amounts to 1.5% per year and is 161-fold higher than in healthy controls. It is also important to realize that the risk for colorectal cancer (CRC) is elevated 10-fold, in addition to a 14-fold risk of pancreatic cancer (Bergquist 2002). These data point to the need of yearly colonoscopies and ultrasound studies after diagnosis of PSC to monitor the high potential for cancer development.

**Table 8. Cancer association of PSC.**

<b>Cholangiocarcinoma</b>	10-20% of PSC patients Yearly risk 1.5% Frequent within 1 year of diagnosis Bilirubin, male gender, long-standing ulcerative colitis, abdominal symptoms, smoking
<b>Colorectal cancer</b>	10-fold risk (PSC and ulcerative colitis) Yearly colonoscopies in ulcerative colitis In ulcerative colitis and AP elevation: consider ERC
<b>Pancreatic cancer</b>	14-fold risk in PSC patients Abdominal ultrasound

## Medical therapy of PSC

Present day data and clinical experience does not suggest that PSC represents a disease curable by medical therapy (Zein 2010, Wiencke 2011). A cure would include the improvement or normalization of abnormal cholestatic biochemical features but more importantly the improvement of sclerosing changes to the intra- and extrahepatic biliary tree, which ultimately lead to biliary cirrhosis, to episodes of cholangitis, and, which carry the risk of cholangiocellular carcinoma. The only available drug that combines a favourable toxicity profile and can lead to a reduction of cholestatic serum parameters currently is ursodeoxycholic acid (UDCA). However, controversy surrounds the use of UDCA (Chapman 2010), which has recently led to guidelines that do not specifically recommend UDCA treatment in all adult patients (Guidelines 2009, Chapman 2010). In two studies an improvement was documented using 20 mg/kg body weight, and 25-30 mg/kg body weight, respectively (Harnois 2001, Mitchell 2001). Both use UDCA doses, which are considerably higher than those common in the therapy of PBC (15 mg/kg body weight). From these data a higher dose appeared to be more beneficial in PSC. However, a study analysing UDCA in bile as a function of oral UDCA dose found that doses exceeding 25 mg/kg body weight are not likely to be useful since the maximum transport of UDCA into the bile leveled off at 25 mg/kg with no further increase (Rost 2004). After these and other initial reports, a meta-analysis was published in 2002 (Chen 2003), which concluded that UDCA therapy improved biochemical parameters but that overall beneficial effect in patients with PSC, in particular survival benefit, was uncertain. A large study appeared to confirm this view; 219 PSC patients in a placebo-controlled trial (Olsson 2005) received 17-23 mg/kg body weight of UDCA and a trend towards better survival and less need for transplantation was seen, but did not reach statistical significance. A difference in the incidence of cholangiocarcinoma was not observed. However, statistical analyses reported in this study concluded that 346 patients would have been required to reach statistical significance. Based on the body of literature available, a positive effect of UDCA at present cannot be excluded, and clearly larger placebo-controlled studies are required. This will only be possible in multicentre trials.

An additional effect of UDCA was reported showing a decrease of the dysplasia in colon polyps associated with UDCA doses as low as 10-15 mg/kg bodyweight (Tung 2001, Pardi 2003). Although this requires confirmation in larger studies the association of PSC with ulcerative colitis in 75% of affected individuals would make this an interesting ancillary effect of UDCA therapy.

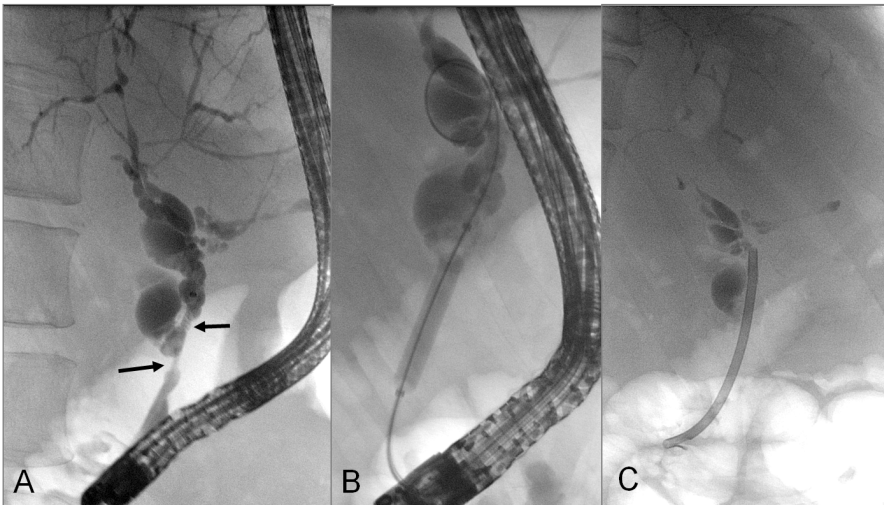
The issue of immunosuppression in PSC is controversial and the majority of centres and publications do not recommend the routine administration of corticosteroids and other immunosuppressants (van Hoogstraten 2000, LaRusso 2006). In PSC one of the most feared and unpredictable complicating factors is bacterial cholangitis and cholangiosepsis (Negm 2011). Immunosuppression would be expected to aggravate this complication. In rare instances such as overlapping features of PSC and autoimmune hepatitis (AIH) (Boberg 2011), immunosuppression may be of benefit but this requires rigorous documentation of AIH, which includes biopsies, autoimmune serology and suggestive biochemistry (Boberg 1996, Beuers 2005).

## Therapy of IBD in PSC

Many PSC patients suffer from a milder course of IBD. Ulcerative colitis is frequently characterized by pancolitis without severe symptoms, rectal sparing or backwash ileitis. Nevertheless the risk of dysplasia and CRC remains significantly higher in PSC patients with ulcerative colitis. Therapeutic intervention is no different than that for IBD without PSC. In this context UDCA appears to provide a beneficial effect for dysplasia development. In a study with 59 PSC patients with ulcerative colitis, UDCA reduced the risk of colonic dysplasia (Tung 2001, Serfaty 2003). UDCA may therefore contribute to the positive modulation of CRC risk in PSC.

### Endoscopic therapy

The most important factor determining the course of PSC is the development of biliary strictures, which carry and increase the risk of septic cholangitis driving biliary fibrosis (Figures 4 and 5). Endoscopic dilatation can improve cholestasis, in some cases biliary stenting (Weismüller 2008), which is not recommended by all gastroenterologists. The combination of endoscopic intervention and UDCA therapy appears to lead to a significant prolongation of transplant-free survival. UDCA alone does not lead to this effect.



**Figure 5. Management of PSC by dilatation of a dominant stricture of the common bile duct (arrows) and subsequent short-term stenting with a plastic stent. In this particular case it turned out that the biliary biopsy revealed cholangiocarcinoma.**

### Liver transplantation in PSC (OLT)

In PSC patients survival has been shown to be reduced both in symptomatic and in asymptomatic patients (Kim 2000, LaRusso 2006), which is in part attributable to the inherent risk of cholangiocarcinoma affecting 10-20% of these patients, and renders decision-making for liver transplantation a formidable challenge. In addition, PSC patients with advanced destructive cholangiopathy frequently exhibit only mild signs of liver failure based upon coagulation abnormalities,

hypoalbuminemia, or complications of portal hypertension (Tischendorf 2007, Strassburg 2009). The course of deterioration to liver failure is often observed after long periods of clinical stability, and frequently proceeds rapidly following septic biliary complications. This is not well predicted by the aforementioned PSC scores, which is also true for the model of end stage liver disease (MELD), the measure for organ allocation in the US and the Eurotransplant member countries.

Two major problems define the challenges involved in the indication for liver transplantation in PSC. First, timing is difficult (Wiesner 1992). PSC patients are young and preemptive liver transplantation carries a higher short-term risk of OLT itself than the most likely short-term natural course of the disease. On the other hand, patients that urgently require OLT because of advanced biliary destruction frequently do not meet priority criteria calculated by the MELD system. Second, the 161-fold increase of cholangiocarcinoma risk (Bergquist 2002) is a risk that may eliminate the option of liver transplantation altogether when evidence of cholangiocarcinoma is detected by diagnostic imaging procedures. The diagnosis of early cholangiocarcinoma is difficult and presently no single diagnostic procedure with high sensitivity and specificity is available (Tischendorf 2006). Moreover, the patients at risk cannot be reliably identified.

In terms of practical management the first point can only be addressed by careful clinical monitoring of PSC patients in experienced hepatological transplant centers, where the likelihood of early complication diagnosis and management, as well as the individualized timing of wait-listing for OLT is higher (Tischendorf 2007). The second point has been addressed in two centres by establishing specific protocols for the management of hilar cholangiocarcinoma and OLT (Sudan 2002, Rea 2005). A rigorous algorithm for non-resectable hilar cholangiocarcinoma patients, that were carefully selected and capable of surviving chemotherapy, radiation therapy and surgery was reported. A multimodal approach including neoadjuvant chemo-/radiation therapy, brachytherapy, chemotherapy, laparotomy and OLT was employed resulting in a 5-year survival of 82%, which did not differ from results in PSC patients without cholangiocarcinoma (Rea 2005). However, although attractive, these interdisciplinary strategies are best limited to studies and experienced hepatological transplant centers.

Overall the results of liver transplantation in PSC are good, leading to 10-year survival rates of around 70% (Graziadei 1999). In our centre the median survival of PSC patients with cholangiocarcinoma was 12.7 months, and all PSC patients, irrespective of OLT, had a mean survival of 112 months (Tischendorf 2006). Recurrence after OLT is difficult to diagnose but appears to occur in up to 25% of patients (Graziadei 1999, Rowe 2008). Liver transplantation continues to represent the only curative option in PSC. Future developments will have to address the lacking sensitivity and specificity of early cholangiocarcinoma detection, the clinical prediction of the disease course and consequently, specific allocation criteria for patients with PSC.

## References

- Ahmed M, Mutimer D, Hathaway M, Hubscher S, McMaster P, Elias E. Liver transplantation for autoimmune hepatitis: a 12-year experience. *Transplant Proc* 1997;29:496. ([Abstract](#))
- Al-Benna S, Willert J, Steinau HU, Steintraesser L. Secondary sclerosing cholangitis, following major burn injury. *Burns* 2011;36(6):e106-10. ([Abstract](#))

- Al-Chalabi T, Boccato S, Portmann BC, McFarlane IG, Heneghan MA. Autoimmune hepatitis (AIH) in the elderly: a systematic retrospective analysis of a large group of consecutive patients with definite AIH followed at a tertiary referral centre. *J Hepatol* 2006;45(4):575-83. ([Abstract](#))
- Al-Chalabi T, Portmann BC, Bernal W, McFarlane IG, Heneghan MA. Autoimmune hepatitis overlap syndromes: an evaluation of treatment response, long-term outcome and survival. *Aliment Pharmacol Ther* 2008;28(2):209-20. ([Abstract](#))
- Alvarez F, Berg PA, Bianchi FB, et al. International Autoimmune Hepatitis Group Report: review of criteria for diagnosis of autoimmune hepatitis. *J Hepatology* 1999;31:929-38. ([Abstract](#))
- Alvarez F, Ciocca M, Canero-Velasco C, et al. Short-term cyclosporine induces a remission of autoimmune hepatitis in children. *J Hepatol* 1999;30:222-7. ([Abstract](#))
- Angulo P, El-Amin O, Carpenter HA, Lindor KD. Development of autoimmune hepatitis in the setting of long-standing primary biliary cirrhosis. *Am J Gastroenterol* 2001;96(10):3021-7. ([Abstract](#))
- Angulo P, Smith C, Jorgensen RA. Budesonide in the treatment of patients with primary biliary cirrhosis with suboptimal response to ursodeoxycholic acid. *Hepatology* 2000;20:471-90. ([Abstract](#))
- Aqel BA, Machicao V, Rosser B, Satyanarayana R, Harnois DM, Dickson RC. Efficacy of tacrolimus in the treatment of steroid refractory autoimmune hepatitis. *J Clin Gastroenterol* 2004;38(9):805-9. ([Abstract](#))
- Bach N, Bodian C, Bodenheimer H, et al. Methotrexate therapy for primary biliary cirrhosis. *Am J Gastroenterol* 2003;98(1):187-93. ([Abstract](#))
- Ben-Ari Z, Dhillon AP, Sherlock S. Autoimmune cholangiopathy: part of the spectrum of autoimmune chronic active hepatitis. *Hepatology* 1993;18(1):10-5. ([Abstract](#))
- Bergquist A, Broome U. Hepatobiliary and extra-hepatic malignancies in primary sclerosing cholangitis. *Best Pract Res Clin Gastroenterol* 2001;15(4):643-56. ([Abstract](#))
- Bergquist A, Ekbohm A, Olsson R, et al. Hepatic and extrahepatic malignancies in primary sclerosing cholangitis. *J Hepatol* 2002;36(3):321-7. ([Abstract](#))
- Beuers U, Rust C. Overlap syndromes. *Semin Liver Dis* 2005;25(3):311-20. ([Abstract](#))
- Boberg KM, Aadland E, Jahnsen J, Raknerud N, Stiris M, Bell H. Incidence and prevalence of primary biliary cirrhosis, primary sclerosing cholangitis, and autoimmune hepatitis in a Norwegian population. *Scand J Gastroenterol* 1998;33:99-103. ([Abstract](#))
- Boberg KM, Bergquist A, Mitchell S, et al. Cholangiocarcinoma in primary sclerosing cholangitis: risk factors and clinical presentation. *Scand J Gastroenterol* 2002;37(10):1205-11. ([Abstract](#))
- Boberg KM, Chapman RW, Hirschfield GM, Lohse AW, Manns MP, Schrupf E. Overlap syndromes: the International Autoimmune Hepatitis Group (IAIHG) position statement on a controversial issue. *J Hepatol* 2011;54(2):374-85. ([Abstract](#))
- Boberg KM, Fausa O, Haaland T, et al. Features of autoimmune hepatitis in primary sclerosing cholangitis: an evaluation of 114 primary sclerosing cholangitis patients according to a scoring system for the diagnosis of autoimmune hepatitis. *Hepatology* 1996;23(6):1369-76. ([Abstract](#))
- Bodenheimer H, Jr., Schaffner F, Pezzullo J. Evaluation of colchicine therapy in primary biliary cirrhosis. *Gastroenterology* 1988;95(1):124-9. ([Abstract](#))
- Bodenheimer HC Jr, Schaffner F, Sternlieb I, et al. A prospective clinical trial of D-penicillamine in the treatment of primary biliary cirrhosis. *Hepatology* 1985;5(6):1139-42. ([Abstract](#))
- Broome U, Glaumann H, Lindstom E, et al. Natural history and outcome in 32 Swedish patients with small duct primary sclerosing cholangitis (PSC). *J Hepatol* 2002;36(5):586-9. ([Abstract](#))
- Calmus Y, Gane P, Rouger P, Poupon R. Hepatic expression of class I and class II major histocompatibility complex molecules in primary biliary cirrhosis: effect of ursodeoxycholic acid. *Hepatology* 1990;11(1):12-5. ([Abstract](#))
- Campsen J, Zimmerman MA, Trotter JF, et al. Liver transplantation for autoimmune hepatitis and the success of aggressive corticosteroid withdrawal. *Liver Transpl* 2008;14(9):1281-6. ([Abstract](#))
- Cancado ELR, Porta G. Autoimmune hepatitis in South America. Dordrecht, Boston, London, Kluwer Academic Publishers, 2000.
- Chapman R, Fevery J, Kallou A, et al. Diagnosis and management of primary sclerosing cholangitis. *Hepatology* 2010;51(2):660-78. ([Abstract](#))



- Chapman RW. Primary sclerosing cholangitis: what is the role of ursodeoxycholic acid in therapy for PSC? *Nat Rev Gastroenterol Hepatol* 2010;7(2):74-5. ([Abstract](#))
- Chazouilleres O, Wendum D, Serfaty L, Montembault S, Rosmorduc O, Poupon R. Primary biliary cirrhosis-autoimmune hepatitis overlap syndrome: clinical features and response to therapy. *Hepatology* 1998;28(2):296-301. ([Abstract](#))
- Chazouilleres O, Wendum D, Serfaty L, Rosmorduc O, Poupon R. Long term outcome and response to therapy of primary biliary cirrhosis-autoimmune hepatitis overlap syndrome. *J Hepatol* 2006;44(2):400-6. ([Abstract](#))
- Chen W, Gluud C. Bile acids for primary sclerosing cholangitis. *Cochrane Database Syst Rev* 2003(2):CD003626. ([Abstract](#))
- Christensen E, Neuberger J, Crowe J, et al. Beneficial effect of azathioprine and prediction of prognosis in primary biliary cirrhosis. Final results of an international trial. *Gastroenterology* 1985;89(5):1084-91. ([Abstract](#))
- Clendenon JN, Aranda-Michel J, Krishna M, Taner CB, Willingham DL. Recurrent liver failure caused by IgG4 associated cholangitis. *Ann Hepatol* 2011;10(4):562-4. ([Abstract](#))
- Colombato LA, Alvarez F, Cote J, Huet PM. Autoimmune cholangiopathy: the result of consecutive primary biliary cirrhosis and autoimmune hepatitis? *Gastroenterology* 1994;107(6):1839-43. ([Abstract](#))
- Czaja AJ, Carpenter HA, Lindor KD. Ursodeoxycholic acid as adjunctive therapy for problematic type 1 autoimmune hepatitis: a randomized placebo-controlled treatment trial. *Hepatology* 1999;30(6):1381-6. ([Abstract](#))
- Czaja AJ, Carpenter HA, Santrach PJ, Moore SB. Significance of HLA DR4 in type 1 autoimmune hepatitis. *Gastroenterology* 1993;105:1502-7. ([Abstract](#))
- Czaja AJ, Carpenter HA. Distinctive clinical phenotype and treatment outcome of type 1 autoimmune hepatitis in the elderly. *Hepatology* 2006;43(3):532-8. ([Abstract](#))
- Czaja AJ, Lindor KD. Failure of budesonide in a pilot study of treatment-dependent autoimmune hepatitis. *Gastroenterology* 2000;119(5):1312-6. ([Abstract](#))
- Czaja AJ, Manns MP. Advances in the diagnosis, pathogenesis, and management of autoimmune hepatitis. *Gastroenterology* 2010;139(1):58-72 e4. ([Abstract](#))
- Danielson A, Prytz H. Oral budesonide for treatment of autoimmune chronic hepatitis. *Aliment Pharmacol Ther* 1994;8:585-90. ([Abstract](#))
- Debray D, Maggiore G, Giradet JP, Mallet E, Bernard O. Efficacy of cyclosporin A in children with type 2 autoimmune hepatitis. *J Pediatr* 1999;135:111-4. ([Abstract](#))
- Devlin J, Donaldson P, Portman B, et al. Recurrence of autoimmune hepatitis following liver transplantation. *Liver Transpl Surg* 1995;1:162-5. ([Abstract](#))
- Dienes HP, Popper H, Manns M, Baumann W, Thoenes W, Meyer zum Büschenfelde K-H. Histologic features in autoimmune hepatitis. *Z Gastroenterol* 1989;27:327-30. ([Abstract](#))
- Donaldson PT. Immunogenetics in liver disease. *Baillieres Clin Gastroenterol* 1996;10(3):533-49. ([Abstract](#))
- Duclos-Vallee JC, Hadengue A, Ganne-Carrie N, et al. Primary biliary cirrhosis-autoimmune hepatitis overlap syndrome. Corticoid resistance and effective treatment by cyclosporine A. *Dig Dis Sci* 1995;40(5):1069-73. ([Abstract](#))
- EASL Clinical Practice Guidelines: management of cholestatic liver diseases. *J Hepatol* 2009;51(2):237-67. ([Abstract](#))
- Efe C, Purnak T, Ozaslan E. Anti TNF-alpha therapy can be a novel treatment option in patients with autoimmune hepatitis. *Aliment Pharmacol Ther* 2010;32(1):115; author reply 6-7. ([Abstract](#))
- Esposito I, Kubisova A, Stiehl A, Kulaksiz H, Schirmacher P. Secondary sclerosing cholangitis after intensive care unit treatment: clues to the histopathological differential diagnosis. *Virchows Arch* 2008;453(4):339-45. ([Abstract](#))
- Fernandez NF, Redeker AG, Vierling JM, Villamil FG, Fong T-L. Cyclosporine therapy in patients with steroid resistant autoimmune hepatitis. *Am J Gastroenterol* 1999;94:241-8. ([Abstract](#))
- Gautam M, Cheruvattath R, Balan V. Recurrence of autoimmune liver disease after liver transplantation: a systematic review. *Liver Transpl* 2006;12(12):1813-24. ([Abstract](#))
- Geall MG, Schoenfield LJ, Summerskill WHJ. Classification and treatment of chronic active liver disease. *Gastroenterology* 1968;55:724-9. ([Abstract](#))
- Gelbmann CM, Rummele P, Wimmer M, et al. Ischemic-like cholangiopathy with secondary sclerosing cholangitis in critically ill patients. *Am J Gastroenterol* 2007;102(6):1221-9. ([Abstract](#))

- Gelpi C SE, Rodriguez-Sanchez JL. Autoantibodies against a serine tRNA-protein complex implicated in cotranslational selenocysteine insertion. *Proc Natl Acad Sci U S A* 1992;89(20):9739-43. ([Abstract](#))
- Gossard AA, Lindor KD. Development of autoimmune hepatitis in primary biliary cirrhosis. *Liver Int* 2007;27(8):1086-90. ([Abstract](#))
- Götz G, Neuhaus R, Bechstein WO, et al. Recurrence of autoimmune hepatitis after liver transplantation. *Transplant Proc* 1999;31:430-1. ([Abstract](#))
- Goulis J, Leandro G, Burroughs AK. Randomised controlled trials of ursodeoxycholic acid therapy for primary biliary cirrhosis: a meta analysis. *Lancet* 1999;354:1053-60. ([Abstract](#))
- Graziadei IW, Wiesner RH, Batts KP, et al. Recurrence of primary sclerosing cholangitis following liver transplantation. *Hepatology* 1999;29(4):1050-6. ([Abstract](#))
- Gregorio GV, Portman B, Reid F, et al. Autoimmune hepatitis in childhood: a 20-year experience. *Hepatology* 1997;25:541-7. ([Abstract](#))
- Gregorio GV, Portmann B, Karani J, et al. Autoimmune hepatitis/sclerosing cholangitis overlap syndrome in childhood: a 16-year prospective study. *Hepatology* 2001;33(3):544-53. ([Abstract](#))
- Harnois DM, Angulo P, Jorgensen RA, Larusso NF, Lindor KD. High-dose ursodeoxycholic acid as a therapy for patients with primary sclerosing cholangitis. *Am J Gastroenterol* 2001;96(5):1558-62. ([Abstract](#))
- Hendrickse MT, Rigney E, Giaffer MH, et al. Low-dose methotrexate is ineffective in primary biliary cirrhosis: long-term results of a placebo-controlled trial. *Gastroenterology* 1999;117(2):400-7. ([Abstract](#))
- Heneghan MA, McFarlane IG. Current and novel immunosuppressive therapy for autoimmune hepatitis. *Hepatology* 2002;35(1):7-13. ([Abstract](#))
- Hennes EM, Oo YH, Schramm C, et al. Mycophenolate mofetil as second line therapy in autoimmune hepatitis? *Am J Gastroenterol* 2008;103(12):3063-70. ([Abstract](#))
- Hennes EM, Zeniya M, Czaja AJ, et al. Simplified criteria for the diagnosis of autoimmune hepatitis. *Hepatology* 2008;48(1):169-76. ([Abstract](#))
- Homborg JC, Abuaf N, Bernard O, et al. Chronic active hepatitis associated with anti liver/kidney microsome type 1: a second type of "autoimmune" hepatitis. *Hepatology* 1987;7:1333-9. ([Abstract](#))
- Ikeda T, Tozuka S, Noguchi O. Effects of additional administration of colchicine in ursodeoxycholic acid-treated patients with primary biliary cirrhosis: a prospective randomized study. *J Hepatol* 1996;24:88-94. ([Abstract](#))
- Johnson PJ, McFarlane IG, Williams R. Azathioprine for long-term maintenance of remission in autoimmune hepatitis. *N Engl J Med* 1995;333:958-63. ([Abstract](#))
- Johnson PJ, McFarlane IG. Meeting report: International autoimmune hepatitis group. *Hepatology* 1993;18:998-1005. ([Abstract](#))
- Jones DE, James OF, Portmann B, Burt AD, Williams R, Hudson M. Development of autoimmune hepatitis following liver transplantation for primary biliary cirrhosis. *Hepatology* 1999;30(1):53-7. ([Abstract](#))
- Jones DE, Watt FE, Metcalf JV, Bassendine MF, James OF. Familial primary biliary cirrhosis reassessed: a geographically-based population study. *J Hepatol* 1999;30(3):402-7. ([Abstract](#))
- Kanzler S, Gerken G, Dienes HP, Meyer zum Büschenfelde K-H, Lohse AW. Cyclophosphamide as alternative immunosuppressive therapy for autoimmune hepatitis - report of three cases. *Z Gastroenterol* 1996;35:571-8. ([Abstract](#))
- Kaplan MM, Alling DW, Zimmerman HJ, et al. A prospective trial of colchicine for primary biliary cirrhosis. *N Engl J Med* 1986;315(23):1448-54. ([Abstract](#))
- Kato Y, Suzuki K, Kumagai M, et al. Familial primary biliary cirrhosis. Immunological and genetic study. *Am J Gastroenterol* 1981;75(3):188-91. ([Abstract](#))
- Kerker N, Hadzic N, Davies ET, et al. De-novo autoimmune hepatitis after liver transplantation. *Lancet* 1998;351(9100):409-13. ([Abstract](#))
- Kim WR, Therneau TM, Wiesner RH, et al. A revised natural history model for primary sclerosing cholangitis. *Mayo Clin Proc* 2000;75(7):688-94. ([Abstract](#))
- Kirk AP, Jain S, Pocock S, Thomas HC, Sherlock S. Late results of the Royal Free Hospital prospective controlled trial of prednisolone therapy in hepatitis B surface antigen negative chronic active hepatitis. *Gut* 1980;21:7893. ([Abstract](#))
- LaRusso NF, Shneider BL, Black D, et al. Primary sclerosing cholangitis: summary of a workshop. *Hepatology* 2006;44(3):746-64. ([Abstract](#))

- Leuschner M, Guldutuna S, You T, Hubner K, Bhatti S, Leuschner U. Ursodeoxycholic acid and prednisolone versus ursodeoxycholic acid and placebo in the treatment of early stages of primary biliary cirrhosis. *J Hepatol* 1996;25(1):49-57. ([Abstract](#))
- Leuschner M, Holtmeier J, Ackermann H, et al. The influence of sulindac on patients with primary biliary cirrhosis that responds incompletely to ursodeoxycholic acid: a pilot study. *Eur J Gastroenterol Hepatol* 2002;14(12):1369-76. ([Abstract](#))
- Leuschner M, Maier KP, Schlichting J, et al. Oral budesonide and ursodeoxycholic acid for treatment of primary biliary cirrhosis: results of a prospective double-blind trial. *Gastroenterology* 1999;117(4):918-25. ([Abstract](#))
- Lombard M, Portmann B, Neuberger J, et al. Cyclosporin A treatment in primary biliary cirrhosis: results of a long-term placebo controlled trial. *Gastroenterology* 1993;104(2):519-26. ([Abstract](#))
- Mackay I, R, Taft LI, Cowling DC. Lupoid hepatitis. *Lancet* 1956;2:1323-6. ([Abstract](#))
- Mackay IR, Gershwin ME. The nature of autoimmune disease. *Semin Liver Dis* 1997;17(1):3-11. ([Abstract](#))
- Manns M, Gerken G, Kyriatsoulis A, Staritz M, Meyer zum Buschenfelde KH. Characterisation of a new subgroup of autoimmune chronic active hepatitis by autoantibodies against a soluble liver antigen. *Lancet* 1987;1(8528):292-4. ([Abstract](#))
- Manns MP, Bahr MJ. Recurrent autoimmune hepatitis after liver transplantation - when non-self becomes self. *Hepatology* 2000;32(4):868-70. ([Abstract](#))
- Manns MP, Czaja AJ, Gorham JD, et al. Diagnosis and management of autoimmune hepatitis. *Hepatology* 2010;51(6):2193-213. ([Abstract](#))
- Manns MP, Griffin KJ, Sullivan KF, Johnson EF. LKM-1 autoantibodies recognize a short linear sequence in P450IID6, a cytochrome P-450 monooxygenase. *J Clin Invest* 1991;88:1370-8. ([Abstract](#))
- Manns MP, Johnson EF, Griffin KJ, Tan EM, Sullivan KF. Major antigen of liver kidney microsomal antibodies in idiopathic autoimmune hepatitis is cytochrome P450db1. *J Clin Invest* 1989;83:1066-72. ([Abstract](#))
- Manns MP, Kruger M. Immunogenetics of chronic liver diseases. *Gastroenterology* 1994;106(6):1676-97. ([Abstract](#))
- Manns MP, Strassburg CP. Autoimmune hepatitis: clinical challenges. *Gastroenterology* 2001;120(6):1502-17. ([Abstract](#))
- Manns MP, Woynarowski M, Kreisel W, et al. Budesonide induces remission more effectively than prednisone in a controlled trial of patients with autoimmune hepatitis. *Gastroenterology* 2010;139(4):1198-206. ([Abstract](#))
- Michieletti P, Wanless IR, Katz A, et al. Antimitochondrial antibody negative primary biliary cirrhosis: a distinct syndrome of autoimmune cholangitis. *Gut* 1994;35(2):260-5. ([Abstract](#))
- Milkiewicz P, Hubscher SG, Skiba G, Hathaway M, Elias E. Recurrence of autoimmune hepatitis after liver transplantation. *Transplantation* 1999;68(2):253-6. ([Abstract](#))
- Mitchell SA, Bansi DS, Hunt N, Von Bergmann K, Fleming KA, Chapman RW. A preliminary trial of high-dose ursodeoxycholic acid in primary sclerosing cholangitis. *Gastroenterology* 2001;121(4):900-7. ([Abstract](#))
- Mitchison HC, Palmer JM, Bassendine MF, Watson AJ, Record CO, James OF. A controlled trial of prednisolone treatment in primary biliary cirrhosis. Three-year results. *J Hepatol* 1992;15(3):336-44.
- Nakamura K, Yoneda M, Yokohama S, et al. Efficacy of ursodeoxycholic acid in Japanese patients with type 1 autoimmune hepatitis [see comments]. *J Gastroenterol Hepatol* 1998;13(5):490-5. ([Abstract](#))
- Negm AA, Schott A, Vonberg RP, et al. Routine bile collection for microbiological analysis during cholangiography and its impact on the management of cholangitis. *Gastrointest Endosc* 2011;72(2):284-91. ([Abstract](#))
- Neuberger J, Portmann B, Calne R, Williams R. Recurrence of autoimmune chronic active hepatitis following orthotopic liver grafting. *Transplantation* 1984;37(4):363-5. ([Abstract](#))
- Newton JL, Burt AD, Park JB, Mathew J, Bassendine MF, James OF. Autoimmune hepatitis in older patients. *Age Ageing* 1997;26(6):441-4. ([Abstract](#))
- Nikias GA, Batts KP, Czaja AJ. The nature and prognostic implications of autoimmune hepatitis with acute presentation. *J Hepatol* 1994;21:866-71. ([Abstract](#))

- Nishioka M, Morshed SA, Kono K, et al. Frequency and significance of antibodies to P450IID6 protein in Japanese patients with chronic hepatitis C. *J Hepatol* 1997;26:992-1000. ([Abstract](#))
- Nishioka M, Morshed SA, McFarlane IG. Geographical variation in the frequency and characteristics of autoimmune liver diseases. Amsterdam: Elsevier; 1998.
- Notghi A, Nestle U, Rittner G, et al. Chromosomal aberrations in patients with primary biliary cirrhosis. *Hum Genet* 1990;85(5):546-50. ([Abstract](#))
- Olsson R, Boberg KM, de Muckadell OS, et al. High-dose ursodeoxycholic acid in primary sclerosing cholangitis: a 5-year multicenter, randomized, controlled study. *Gastroenterology* 2005;129(5):1464-72. ([Abstract](#))
- Pardi DS, Loftus EV, Jr., Kremers WK, Keach J, Lindor KD. Ursodeoxycholic acid as a chemopreventive agent in patients with ulcerative colitis and primary sclerosing cholangitis. *Gastroenterology* 2003;124(4):889-93. ([Abstract](#))
- Paumgartner G, Beuers U. Ursodeoxycholic acid in cholestatic liver disease: mechanisms of action and therapeutic use revisited. *Hepatology* 2002;36(3):525-31. ([Abstract](#))
- Ponsioen CY, Vrouenraets SM, Prawirodirdjo W, et al. Natural history of primary sclerosing cholangitis and prognostic value of cholangiography in a Dutch population. *Gut* 2002;51(4):562-6. ([Abstract](#))
- Pothoff A, Deterding K, Trautwein C, et al. Steroid treatment for severe acute cryptogenic hepatitis. *Z Gastroenterol* 2007;45(1):15-9. ([Abstract](#))
- Poupon R, Chazouilleres O, Corpechot C, Chretien Y. Development of autoimmune hepatitis in patients with typical primary biliary cirrhosis. *Hepatology* 2006;44(1):85-90. ([Abstract](#))
- Poupon RE, Huet PM, Poupon R, Bonnand AM, Nhieu JT, Zafrani ES. A randomized trial comparing colchicine and ursodeoxycholic acid combination to ursodeoxycholic acid in primary biliary cirrhosis. UDCA-PBC Study Group. *Hepatology* 1996;24(5):1098-103. ([Abstract](#))
- Poupon RE, Lindor KD, Cauch-Dudek K. Combined analysis of randomized controlled trials of ursodeoxycholic acid in primary biliary cirrhosis. *Gastroenterology* 1997;113:884-90. ([Abstract](#))
- Poupon RE, Lindor KD, Pares A, Chazouilleres O, Poupon R, Heathcote EJ. Combined analysis of the effect of treatment with ursodeoxycholic acid on histologic progression in primary biliary cirrhosis. *J Hepatol* 2003;39(1):12-6. ([Abstract](#))
- Prados E, Cuervas-Mons V, De La Mata M, et al. Outcome of autoimmune hepatitis after liver transplantation. *Transplantation* 1998;66:1645-50. ([Abstract](#))
- Prelog M. Aging of the immune system: a risk factor for autoimmunity? *Autoimmun Rev* 2006;5(2):136-9. ([Abstract](#))
- Raedsch R, Stiehl A, Walker S, Scherrmann JM, Kommerell B. [Combined ursodeoxycholic acid plus colchicine-treatment of primary biliary cirrhosis: results of a placebo-controlled double-blind study]. *Z Gastroenterol* 1992;30 Suppl 1:55-7. ([Abstract](#))
- Ramos-Casals M, Brito-Zeron P, Soto MJ, Cuadrado MJ, Khamashta MA. Autoimmune diseases induced by TNF-targeted therapies. *Best Pract Res Clin Rheumatol* 2008;22(5):847-61. ([Abstract](#))
- Ratziu V, Samuel D, Sebah M, et al. Long-term follow-up after liver transplantation for autoimmune hepatitis: evidence of recurrence of primary disease. *J Hepatol* 1999;30(1):131-41. ([Abstract](#))
- Rea DJ, Heimbach JK, Rosen CB, et al. Liver transplantation with neoadjuvant chemoradiation is more effective than resection for hilar cholangiocarcinoma. *Ann Surg* 2005;242(3):451-8; discussion 8-61. ([Abstract](#))
- Rebollo Bernardez J, Cifuentes Mimoso C, Pinar Moreno A, et al. Deflazacort for long-term maintenance of remission in type I autoimmune hepatitis. *Rev Esp Enferm Dig* 1999;91(9):630-8. ([Abstract](#))
- Richardson PD, James PD, Ryder SD. Mycophenolate mofetil for maintenance of remission in autoimmune hepatitis in patients resistant to or intolerant of azathioprine. *J Hepatol* 2000;33(3):371-5. ([Abstract](#))
- Rost D, Rudolph G, Kloeters-Plachky P, Stiehl A. Effect of high-dose ursodeoxycholic acid on its biliary enrichment in primary sclerosing cholangitis. *Hepatology* 2004;40(3):693-8. ([Abstract](#))
- Rowe IA, Webb K, Gunson BK, Mehta N, Haque S, Neuberger J. The impact of disease recurrence on graft survival following liver transplantation: a single centre experience. *Transpl Int* 2008;21(5):459-65. ([Abstract](#))

- Rust C, Beuers U. Overlap syndromes among autoimmune liver diseases. *World J Gastroenterol* 2008;14(21):3368-73. ([Abstract](#))
- Salcedo M, Vaquero J, Banares R, et al. Response to steroids in de novo autoimmune hepatitis after liver transplantation. *Hepatology* 2002;35(2):349-56. ([Abstract](#))
- Sanchez-Urdazpal L, Czaja AJ, Van Holk B. Prognostic features and role of liver transplantation in severe corticoid-treated autoimmune chronic active hepatitis. *Hepatology* 1991;15:215-21. ([Abstract](#))
- Schramm C, Kanzler S, zum Buschenfelde KH, Galle PR, Lohse AW. Autoimmune hepatitis in the elderly. *Am J Gastroenterol* 2001;96(5):1587-91. ([Abstract](#))
- Schreuder TC, Hubscher SG, Neuberger J. Autoimmune liver diseases and recurrence after orthotopic liver transplantation: what have we learned so far? *Transpl Int* 2009;22(2):144-52. ([Abstract](#))
- Serfaty L, De Leusse A, Rosmorduc O, et al. Ursodeoxycholic acid therapy and the risk of colorectal adenoma in patients with primary biliary cirrhosis: an observational study. *Hepatology* 2003;38(1):203-9. ([Abstract](#))
- Silveira MG, Talwalkar JA, Angulo P, Lindor KD. Overlap of autoimmune hepatitis and primary biliary cirrhosis: long-term outcomes. *Am J Gastroenterol* 2007;102(6):1244-50. ([Abstract](#))
- Soloway RD, Summerskill WH, Baggenstoss AH, et al. Clinical, biochemical, and histological remission of severe chronic active liver disease: a controlled study of treatments and early prognosis. *Gastroenterology* 1972;63(5):820-33. ([Abstract](#))
- Stechemesser E, Klein R, Berg PA. Characterization and clinical relevance of liver-pancreas antibodies in autoimmune hepatitis. *Hepatology* 1993;18:1-9. ([Abstract](#))
- Strassburg CP, Bahr MJ, Becker T, Klempnauer J, Manns MP. [Progress in immunosuppression]. *Chirurg* 2008;79(2):149-56. ([Abstract](#))
- Strassburg CP, Becker T, Klempnauer J, Manns MP. Liver transplantation: deciding between need and donor allocation. *Internist (Berl)* 2004;45(11):1233-45. ([Abstract](#))
- Strassburg CP, Jaeckel E, Manns MP. Anti-mitochondrial antibodies and other immunological tests in primary biliary cirrhosis. *Eur J Gastroenterol Hepatol* 1999;11(6):595-601. ([Abstract](#))
- Strassburg CP, Manns MP. Liver transplantation: indications and results. *Internist (Berl)* 2009. ([Abstract](#))
- Strassburg CP, Manns MP. Primary biliary liver cirrhosis and overlap syndrome. Diagnosis and therapy. *Internist (Berl)* 2004;45(1):16-26. ([Abstract](#))
- Strassburg CP, Manns MP. Autoantibodies and autoantigens in autoimmune hepatitis. *Semin Liver Dis* 2002;22(4):339-52. ([Abstract](#))
- Strassburg CP, Manns MP. Autoimmune hepatitis in the elderly: what is the difference? *J Hepatol* 2006;45(4):480-2. ([Abstract](#))
- Strassburg CP, Manns MP. Autoimmune hepatitis versus viral hepatitis C. *Liver* 1995;15:225-32. ([Abstract](#))
- Strassburg CP, Manns MP. Primär biliäre Zirrhose und primär sklerosierende Cholangitis. *Internistische Praxis* 1996;36:57-74.
- Strassburg CP, Obermayer-Straub P, Alex B, et al. Autoantibodies against glucuronosyltransferases differ between viral hepatitis and autoimmune hepatitis. *Gastroenterology* 1996;111(6):1576-86. ([Abstract](#))
- Strassburg CP, Obermayer-Straub P, Manns MP. Autoimmunity in liver diseases. *Clin Rev Allergy Immunol* 2000;18(2):127-39. ([Abstract](#))
- Strassburg CP. [Autoimmune liver diseases and their overlap syndromes]. *Praxis (Bern)* 1994;2006;95(36):1363-81. ([Abstract](#))
- Stravitz RT, Lefkowitz JH, Fontana RJ, et al. Autoimmune acute liver failure: proposed clinical and histological criteria. *Hepatology* 2011;53(2):517-26. ([Abstract](#))
- Sudan D, DeRoover A, Chinnakotla S, et al. Radiochemotherapy and transplantation allow long-term survival for nonresectable hilar cholangiocarcinoma. *Am J Transplant* 2002;2(8):774-9. ([Abstract](#))
- Takuma K, Kamisawa T, Igarashi Y. Autoimmune pancreatitis and IgG4-related sclerosing cholangitis. *Curr Opin Rheumatol* 2011;23(1):80-7. ([Abstract](#))
- Talor E, Rose NR. Hypothesis: the aging paradox and autoimmune disease. *Autoimmunity* 1991;8(3):245-9. ([Abstract](#))
- Terjung B, Spengler U, Sauerbruch T, Worman HJ. "Atypical p-ANCA" in IBD and hepatobiliary disorders react with a 50-kilodalton nuclear envelope protein of neutrophils and myeloid cell lines. *Gastroenterology* 2000;119(2):310-22. ([Abstract](#))

- Thalen A, Brattsand R. Synthesis and anti-inflammatory properties of budesonide, a new non-halogenated glucocorticoid with high local activity. *Arzneimittelforschung* 1979;29(11):1687-90. ([Abstract](#))
- Tillmann HL, Jackel E, Manns MP. Liver transplantation in autoimmune liver disease--selection of patients. *Hepatogastroenterology* 1999;46(30):3053-9. ([Abstract](#))
- Tischendorf JJ, Hecker H, Kruger M, Manns MP, Meier PN. Characterization, outcome, and prognosis in 273 patients with primary sclerosing cholangitis: A single center study. *Am J Gastroenterol* 2007;102(1):107-14. ([Abstract](#))
- Tischendorf JJ, Meier PN, Strassburg CP, et al. Characterization and clinical course of hepatobiliary carcinoma in patients with primary sclerosing cholangitis. *Scand J Gastroenterol* 2006;41(10):1227-34. ([Abstract](#))
- Tsuji K, Watanabe Y, Van De Water J, et al. Familial primary biliary cirrhosis in Hiroshima. *J Autoimmun* 1999;13(1):171-8. ([Abstract](#))
- Tung BY, Emond MJ, Haggitt RC, et al. Ursodiol use is associated with lower prevalence of colonic neoplasia in patients with ulcerative colitis and primary sclerosing cholangitis. *Ann Intern Med* 2001;134(2):89-95. ([Abstract](#))
- Uibo R, Salupere V. The epidemiology of primary biliary cirrhosis: immunological problems. *Hepatogastroenterology* 1999;46(30):3048-52. ([Abstract](#))
- Umekita K, Miyauchi S, Ueno S, et al. Improvement of rheumatoid arthritis and autoimmune hepatitis in a patient treated with the tumor necrosis factor inhibitor, etanercept. *Intern Med* 2011;50(11):1245-9. ([Abstract](#))
- van Hoogstraten HJ, Vleggaar FP, Boland GJ, et al. Budesonide or prednisone in combination with ursodeoxycholic acid in primary sclerosing cholangitis: a randomized double-blind pilot study. Belgian-Dutch PSC Study Group [see comments]. *Am J Gastroenterol* 2000;95(8):2015-22. ([Abstract](#))
- Van Steenberghe W, Sciot R, Van Eyken P, Desmet V, Fevery J. Combined treatment with methotrexate and ursodeoxycholic acid in non-cirrhotic primary biliary cirrhosis. *Acta Clin Belg* 1996;51(1):8-18. ([Abstract](#))
- Van Thiel DH, Wright H, Carroll P, et al. Tacrolimus: A potential new treatment for autoimmune chronic active hepatitis: results of an open-label preliminary trial. *Am J Gastroenterol* 1995;90:771-6. ([Abstract](#))
- Vogel A, Heinrich E, Bahr MJ, et al. Long-term outcome of liver transplantation for autoimmune hepatitis. *Clin Transplant* 2004;18(1):62-9. ([Abstract](#))
- Volkman M, Luthle D, Zentgraf H, et al. SLA/LP/tRNP((Ser)Sec) antigen in autoimmune hepatitis: identification of the native protein in human hepatic cell extract. *J Autoimmun* 2010;34(1):59-65. ([Abstract](#))
- Volkman M, Martin L, Baurle A, et al. Soluble liver antigen: isolation of a 35-kd recombinant protein (SLA-p35) specifically recognizing sera from patients with autoimmune hepatitis. *Hepatology* 2001;33(3):591-6. ([Abstract](#))
- von Figura G, Stephani J, Wagner M, et al. Secondary sclerosing cholangitis after chemotherapy with bevacizumab and paclitaxel. *Endoscopy* 2009;41 Suppl 2:E153-4. ([Abstract](#))
- Waldenström J. Leber, Blutproteine und Nahrungseiweisse. *Dtsch Gesellsch Verd Stoffw* 1950;15:113-9. ([Abstract](#))
- Warnes TW, Smith A, Lee FI, Haboubi NY, Johnson PJ, Hunt L. A controlled trial of colchicine in primary biliary cirrhosis. Trial design and preliminary report. *J Hepatol* 1987;5(1):1-7. ([Abstract](#))
- Webster GJ, Pereira SP, Chapman RW. Autoimmune pancreatitis/IgG4-associated cholangitis and primary sclerosing cholangitis--overlapping or separate diseases? *J Hepatol* 2009;51(2):398-402. ([Abstract](#))
- Weismüller TJ, Wedemeyer J, Kubicka S, Strassburg CP, Manns MP. The challenges in primary sclerosing cholangitis - Aetiopathogenesis, autoimmunity, management and malignancy. *J Hepatol* 2008;48(S1):S38-S57. ([Abstract](#))
- Wiegand J, Schuler A, Kanzler S, et al. Budesonide in previously untreated autoimmune hepatitis. *Liver Int* 2005;25(5):927-34. ([Abstract](#))
- Wiencke K, Boberg KM. Current consensus on the management of primary sclerosing cholangitis. *Clin Res Hepatol Gastroenterol* 2011. ([Abstract](#))
- Wies I, Brunner S, Henninger J, et al. Identification of target antigen for SLA/LP autoantibodies in autoimmune hepatitis [see comments]. *Lancet* 2000;355(9214):1510-5. ([Abstract](#))
- Wiesner RH, Ludwig J, Lindor KD, et al. A controlled trial of cyclosporine in the treatment of primary biliary cirrhosis. *N Engl J Med* 1990;322(20):1419-24. ([Abstract](#))

- Wiesner RH, Porayko MK, Dickson ER, et al. Selection and timing of liver transplantation in primary biliary cirrhosis and primary sclerosing cholangitis. *Hepatology* 1992;16(5):1290-9. ([Abstract](#))
- Wolfhagen FHJ, van Hoogstraaten HJF, van Buuren, H.R. Triple therapy with ursodeoxycholic acid, prednisone, and azathioprine in primary biliary cirrhosis: a 1 year randomized, placebo controlled study. *J Hepatol* 1998;29:736-42. ([Abstract](#))
- Wright HL, Bou-Abboud CF, Hassanenstien T, et al. Disease recurrence and rejection following liver transplantation for autoimmune chronic active liver disease. *Transplantation* 1992;53:136-9. ([Abstract](#))
- Zein CO, Lindor KD. Latest and emerging therapies for primary biliary cirrhosis and primary sclerosing cholangitis. *Curr Gastroenterol Rep* 2010;12(1):13-22. ([Abstract](#))
- Zhang L, Lewis JT, Abraham SC, et al. IgG4+ plasma cell infiltrates in liver explants with primary sclerosing cholangitis. *Am J Surg Pathol* 2011;34(1):88-94. ([Abstract](#))

## 28. Alcoholic Hepatitis

*Claus Niederau*

### **Health and social problems due to alcohol overconsumption**

Mortality due to alcohol overconsumption is high, in particular among young men (Mokdad 2000). Alcohol overconsumption not only increases the risk for liver disease but is also responsible for malignancies, accidents, violence, and social problems (Bellentani 1997, Vaillant 1995). Alcohol consumption in excess of 20-30 g for women and 40-60 g for men per day markedly increases the risk for liver disease (Becker 1996, Lucey 2008). However, liver cirrhosis is seen only in a minority of subjects with high alcohol consumption; less than 10% of subjects who drink more than 120 g of alcohol daily have cirrhosis (Bellentani 1997). In addition to the level of alcohol consumption, various other factors such as sex, other genetic characteristics and comorbidities contribute to the risk for liver disease (Nishigushi 1991, Becker 1996, Bellentani 1997, McCollough 1998, de Alwis 2007, Lucey 2009).

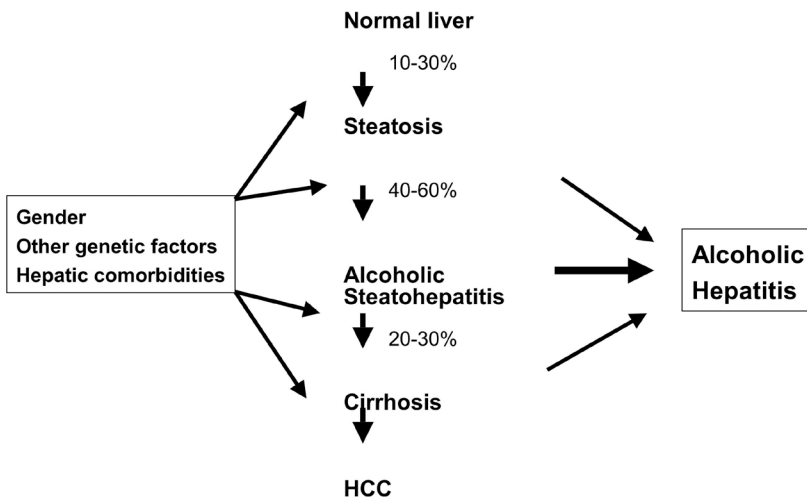
### **Classification and natural history of alcoholic liver disease**

Alcohol overconsumption most often causes fat accumulation of hepatocytes, called hepatic steatosis (Figure 1). Alcohol-induced steatosis is in general reversible after alcohol abstinence. Continued alcohol overconsumption in the presence of steatosis markedly increases the risk for development of hepatitis, fibrosis and cirrhosis (Teli 1995, Cubero 2009). Patients with alcohol-induced cirrhosis have a significantly increased risk for hepatocellular carcinoma (McCollough 1998). Patients with only fatty liver in the absence of inflammation and fibrosis have a much lower risk for development of cirrhosis than those with fatty liver plus presence of inflammation and fibrosis. The latter group of patients with alcoholic fatty liver, inflammation and fibrosis is defined as alcoholic steatohepatitis (ASH). The liver histology of patients with ASH is similar when compared to patients with non-alcoholic steatohepatitis (NASH) that is often associated with obesity and diabetes (Ludwig 1980, Brunt 1999).



The diagnosis of ASH by liver biopsy thus helps to define the risk for development of cirrhosis. The histological diagnosis of ASH however should not be confused with the term “alcoholic hepatitis” that is also called “acute alcoholic hepatitis” although its course can be a rather chronic one (Lucey 2009). This overview article concentrates on “alcoholic hepatitis” which is a clinical diagnosis of a rather acute development of jaundice and liver failure associated with a high short-term mortality.

It is not exactly known which factor(s) set off the development of severe alcohol hepatitis. In general, pathogenesis and individual predisposition are governed by gene-environment interactions in all types of alcoholic liver disease (Figure 1). Based on the “second hit” or “multiple hits” hypothesis, patients are predisposed to progressive alcoholic liver disease when a specific combination of gene and environmental interaction exists (Tsukamoto 2009). A loss or gain of function genetic model has become a popular experimental approach to test the role of a gene as a second hit. Significant interactions for progressive development of alcoholic liver disease have been proven in particular for female gender, obesity, various drugs, iron overload, and hepatitis B and C viral infections (Mueller 2009, Machado 2009, Cubero 2009). These factors may also interact in the development of hepatocellular carcinoma (HCC).



**Figure 1. Effects of alcohol overconsumption on the liver.**

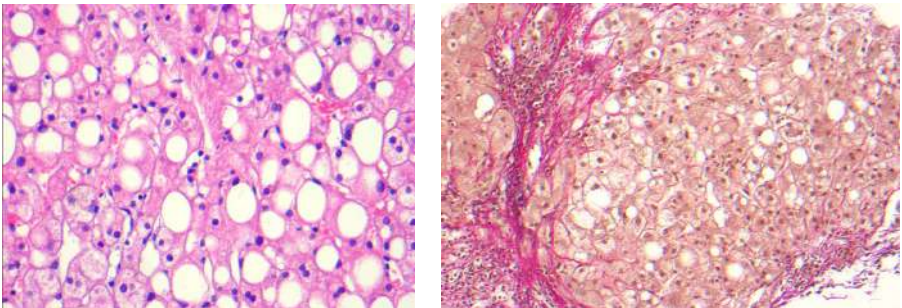
A liver biopsy in someone with “alcoholic hepatitis” is often similar to a histological feature of ASH. Most patients with histological features of ASH however will not develop “alcoholic hepatitis”. Alcohol overconsumption leads to a severe form of hepatitis and liver failure associated with a high short-term mortality only in some subjects. Such alcoholic hepatitis may be seen with or without preexisting cirrhosis.

## Clinical features and diagnosis of alcoholic hepatitis

Alcoholic hepatitis is a clinical diagnosis characterized by the rapid development of jaundice and liver failure most often due to long-term alcohol overconsumption (Naveau 1997, McCollough 1998, Lucey 2009). Further characteristics include fever, ascites, and in some patients hepatic encephalopathy as well. Usually the liver is enlarged and tender. Women have a higher risk for alcoholic hepatitis than men assuming that both genders drink the same amount of alcohol. The type of alcohol is not associated with the risk. Prevalence was 20% in a cohort of 1604 patients who had a history of heavy alcohol consumption and underwent a liver biopsy (Naveau 1997).

Laboratory tests show increases in serum aspartate aminotransferase (AST) to approximately twice the upper limit of normal (ULN), while the increase in alanine aminotransferase (ALT) is less pronounced. The ratio of AST to ALT is typically  $>2$  (Cohen 1979, Matloff 1980). Other laboratory abnormalities include increases in peripheral leukocytes, serum bilirubin, and international normalized ratio (INR) (Mathurin 2002, Orrego 1979). In the presence of an increase in serum creatinine there is a high risk for development of an often lethal hepatorenal syndrome (Multimer 1993).

A liver biopsy usually shows big fat droplets and ballooning of hepatocytes that may also include alcoholic hyaline (also called Mallory bodies); these changes are accompanied by neutrophil infiltration and intrasinusoidal fibrosis (Figures 2 & 3) (MacSween 1986).



**Figures 2 & 3. Liver biopsies of alcoholic hepatitis.**

The diagnosis of alcoholic steatohepatitis (ASH) requires the presence of fibrosis. The role of liver biopsy in defining prognosis and treatment of alcoholic hepatitis in the clinical setting remains unclear. Today, prognosis is usually not based on liver biopsy but on clinical scoring systems (Lucey 2009).

Ultrasound is routinely done to look for hepatocellular carcinoma, biliary obstruction, ascites, splenomegaly, portal vein thrombosis, and signs of portal hypertension. Ascites should be checked for spontaneous bacterial peritonitis routinely.

Differential diagnosis of alcoholic hepatitis includes severe non-alcoholic steatohepatitis (NASH), acute or chronic viral hepatitis, drug-induced injury,

autoimmune hepatitis, and Wilson's disease. NASH shares the histological features of ASH except for the rapid development of jaundice and liver failure.

After discontinuation of alcohol consumption the majority of patients will recover from alcoholic hepatitis although jaundice, ascites and encephalopathy may persist for weeks or months (Alexander 1971). Even so, a considerable percentage of patients with alcoholic hepatitis still die today despite adequate treatment and abstinence (Mathurin 2002, Orrego 1979).

## Course and severity

Severe alcoholic hepatitis occurs in a small fraction of patients who overconsume alcohol. The 28-day mortality is high and ranges from 30% to 50% in most cohorts (Cohen 2009). Various scores have been used to predict the prognosis of alcoholic hepatitis. Maddrey's discriminant function (Maddrey 1978) and the Model for End-Stage Liver Disease (MELD; <http://goo.gl/ksgu4>) score may help to identify patients who can benefit with corticosteroids. Most scores share some important characteristics such as serum bilirubin and prothrombin time (Srikureja 2005). Maddrey's discriminant function is calculated as  $[4.6 \times (\text{prothrombin time} - \text{control prothrombin time, in seconds})] + \text{serum bilirubin (mg/dL)}$ . A value of  $>32$  indicates severe alcoholic hepatitis and consequently calls for the use of corticosteroids (Maddrey 1978). In two retrospective studies, the MELD score predicted short-term mortality in alcoholic hepatitis as well as or even better than Maddrey's discriminant function (Dunn 2005, Srikureja 2005). A MELD score  $>21$  was associated with a 90-day mortality of 20%. The Lille score is based on pretreatment data and on the response of serum bilirubin to a 7-day treatment with corticosteroids and has been used to determine whether corticosteroids should be discontinued after 7 days because of treatment failure (Forrest 2005, Dunn 2005, Louvet 2007). Patients with Maddrey's discriminant function of  $<32$  usually have mild disease with a short-term survival of more than 90% and will not benefit from corticosteroid treatment.

Investigators reported the results of a stepwise logistic-regression identifying variables related to survival 1-4 months after hospital admission in patients with alcoholic hepatitis (Forrest 2005); by using this data the Glasgow alcoholic hepatitis score was developed (not to be confused with the Glasgow coma score). The score, which includes age, peripheral leukocytes, urea nitrogen, bilirubin, and prothrombin time, may help to identify high-risk patients who should receive corticosteroids. Patients with a Maddrey's discriminant function  $>32$  and a Glasgow alcoholic hepatitis score of  $>9$  who were treated with corticosteroids had an 84-day survival of 59%, while untreated patients had a 38% survival (Forrest 2007). In one study the Glasgow score indicated which subgroup of patients with a high score of Maddrey's discriminant function would benefit from corticosteroid therapy (Forrest 2007).

Child-Pugh (CP) and MELD scores have been widely used to predict survival in cirrhotic patients. Recent studies have suggested that the addition of serum sodium to MELD (MELD-Na score) may improve its prognostic accuracy. Another recent study compared the performance of CP, MELD, and MELD-Na scores in predicting 6-month mortality in patients with alcoholic cirrhosis, and developed a new prognostic score. In this study two French centres (Boursier 2009) enrolled 520 patients (mean age  $56.4 \pm 10.2$  years) with alcoholic cirrhosis randomly allocated

into two groups. MELD, MELD-Na1, and MELD-Na2 were calculated according to UNOS recommendations. Frequencies of CP classes were: A - 29.6%, B - 25.8%, C - 44.6%. Of the 520 patients 93 died during the 6-month follow-up. In the whole population, the values of CP, MELD, MELD-Na1, and MELD-Na2 for prediction of 6-month mortality were similar. Multivariate analysis identified age, bilirubin, urea, prothrombin time, sodium, and alkaline phosphatase as independent predictors of 6-month mortality. The score combining these 6 variables was named the Prognostic Score for Alcoholic Cirrhosis (PSAC) and compared to the 4 other scores. The predictive value of PSAC was better than all other scores except for MELD-Na2. By stepwise multivariate analysis, PSAC was identified as independently associated with 6-month mortality at the first step, and CP at the second. The new PSAC score may improve the prognostic accuracy to predict the 6-month outcome (Boursier 2009).

Another recent study analyzed the outcome of 79 patients who were admitted to an Intensive Care Unit (ICU) because of alcoholic liver disease (Rye 2009). The value of various scores was analyzed for predicting mortality including the Acute Physiology, Age and Chronic Health Evaluation (APACHE II), Sequential Organ Failure Assessment (SOFA), CP, and MELD scores. The major reason for admission was sepsis (44%). The observed mortality in the ICU was 49% and hospital mortality 68%. Compared to survivors, non-survivors had a significantly higher serum bilirubin, creatinine and prothrombin time, and lower GCS and length of ICU stay. Survival was affected by cardiac arrest pre-admission (mortality 75%) and number of organs supported (mortality 8% with no organ support, 79%  $\geq 2$  organs, 100%  $\geq 3$  organs). Renal replacement therapy was associated with 100% mortality. Mortality due to GI bleeding was only 33%. Thus, cirrhotics admitted to the ICU with cardiac arrest pre-admission, need for renal replacement therapy, or multiple organ support have a poor prognosis. The predictive accuracy of SOFA and MELD scores were superior to APACHE II and Child-Pugh scores in cirrhotic patients (Rye 2009).

A further study analyzed the mortality of 105 patients presenting with alcoholic hepatitis (Hussain 2009). Patients were evaluated by the modified discriminant function (mDF) for alcoholic liver disease, CP score, and Glasgow alcoholic hepatitis score (GAHS). Mean survival for those alive at the end of the study ( $n=36$ ) was  $34.6 \pm 17.8$  months. Mean survival for those who died ( $n=50$ ) was  $13.2 \pm 14.4$  months. The mDF, CP and GAHS scores were significant predictors of mortality in this population. Prothrombin time was also a significant predictor of mortality (Hussain 2009).

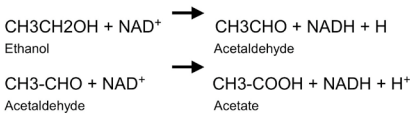
## Mechanisms of alcohol-related liver injury

Alcoholic liver disease is initiated by different cell types in the liver and a number of different factors including products derived from alcohol-induced inflammation, ethanol metabolites, and indirect reactions from those metabolites, as well as genetic predisposition (Colmenero 2007). Ethanol oxidation results in the production of metabolites that have been shown to bind and form protein adducts, and to increase inflammatory, fibrotic and cirrhotic responses. Lipopolysaccharide (LPS) has many deleterious effects and plays a significant role in a number of disease processes by increasing inflammatory cytokine release. In alcoholic liver disease, LPS is thought

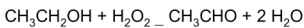
to be derived from a breakdown in the intestinal wall enabling LPS from resident gut bacterial cell walls to leak into the blood stream. The ability of adducts and LPS to independently stimulate various cells of the liver provides for a two-hit mechanism by which various biological responses are induced and result in liver injury.

Alcohol (ethanol) can be oxidized by various enzymatic and non-enzymatic pathways (Figures 2 and 3). In hepatocytes the most important pathway is oxidation of ethanol via alcohol dehydrogenase (ADH) to acetaldehyde (Figure 4). In mitochondria, acetaldehyde is converted to acetate and in turn acetate is converted to acetyl CoA, which leads the two-carbon molecule into the TCA (tricarboxylic acid cycle).

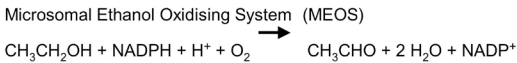
#### Alcohol dehydrogenase (ADH)



#### Catalase



#### Cytochrome P450



**Figure 4. Oxidation of ethanol to acetaldehyde by enzymatic pathways.**

This oxidation generates reducing equivalents, primarily reduced nicotinamide adenine dinucleotide (NAD), i.e., NADH. The changes in the NADH–NAD<sup>+</sup> potential in the liver inhibit both fatty acid oxidation and the TAC and may thereby increase lipogenesis (You 2004a). Ethanol has also been shown to increase lipid metabolism by inhibiting peroxisome-proliferator-activated receptor  $\alpha$  (PPAR $\alpha$ ) and AMP kinase as well as by stimulation of sterol regulatory element-binding protein (Fischer 2003, You 2004b, Ji 2006). All these mechanisms lead to hepatic steatosis. Further enzymatic pathways of ethanol oxidation include catalase and the “Microsomal Ethanol Oxidizing System” (MEOS), a cytochrome P450 component. Oxidation of ethanol to acetaldehyde may also be due to non-enzymatic free radical pathways (Figure 5). These include strong oxidizing intermediates such as the hydroxyl radical which can abstract a hydrogen atom from ethanol, preferentially producing the 1-hydroxyethyl radical; hypervalent iron complexes may also catalyse this reaction without involvement of  $\bullet\text{OH}$  (Reinke 1994, Welch 2002, Qian 1999). Hydroxyethyl radicals may then react with oxygen to form a peroxy radical intermediate which can rearrange to release acetaldehyde and superoxide. Hydroxyethyl radicals can also react with proteins to produce antigenic adducts or induce mitochondrial permeability transition (Clot 1995, Sakurai 2000).

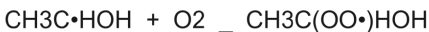
There are probably various other mechanisms by which ethanol may cause or contribute to liver disease. Ethanol increases the translocation of lipopolysaccharide

(LPS) from the small and large intestines to the portal vein and on to the liver. In Kupffer cells LPS can bind to CD14, which combines with toll-like receptor 4 (TLR4) thereby activating multiple cytokine genes (Schaffert 2009). In addition, NADPH oxidase may release reactive oxygen species (ROS) that activate cytokine genes within Kupffer cells, hepatocytes, and hepatic stellate cells. These cytokines including TNF- $\alpha$  may cause fever, anorexia, and weight loss. Interleukin-8 and monocyte chemoattractant protein 1 (MCP-1) have been shown to attract neutrophils and macrophages. Platelet-derived growth factor (PDGF) and transforming growth factor b (TGF-b) contribute to the activation, migration, and multiplication of hepatic stellate cells, thereby promoting liver fibrosis.

Hydroxyl radicals abstract a hydrogen atom from ethanol,  
preferentially producing the 1-hydroxyethyl radical;  
hypervalent iron complexes catalyze this reaction



Hydroxyethyl radicals react with oxygen to form peroxy radical intermediates  
which then rearrange to release acetaldehyde and superoxide



Hydroxyethyl radicals react with proteins to produce antigenic adduct  
or induce mitochondrial permeability transition

**Figure 5. Oxidation of ethanol to acetaldehyde by non-enzymatic free radical pathways.**

In the hepatocyte, ethanol is converted to acetaldehyde by the cytosolic enzyme alcohol dehydrogenase (ADH) and the microsomal enzyme cytochrome P450 2E1 (CYP2E1). Acetaldehyde is converted to acetate. These reactions produce NADH and inhibit the oxidation of triglycerides and fatty acids. ROS released by CYP2E1 and mitochondria cause lipid peroxidation. Inhibition of proteasomes due to ethanol disturbs protein catabolism and may be partly responsible for the formation of Mallory bodies. Reduction in enzymes that convert homocysteine to methionine may increase homocysteine, thereby injuring the endoplasmic reticulum. Decrease in binding of peroxisome proliferator-activated receptor  $\alpha$  (PPAR- $\alpha$ ) to DNA reduces the expression of genes involved in fatty acid oxidation.

Glutathione transport from the cytosol into the mitochondria is reduced by ethanol. Ethanol may also activate Fas and TNF receptor 1 (TNF-R1) thereby activating caspase 8, causing mitochondrial injury and opening the mitochondrial transition pore (MTP), releasing cytochrome c, and activating caspases; all these processes contribute to apoptosis. Activation of TNF-R1 leads to nuclear factor kappa B (NFkB) activation (Schaffert 2009).

Gut permeability and the circulating LPS endotoxin levels of the outer wall of gram-negative bacteria are increased in patients with alcoholic liver injury (Uesugi 2002, Bjarnson 1984, Urbaschel 2001). In various animal studies alcohol exposure promoted the transfer of LPS endotoxins from the intestine into portal blood (West 2005). Oral treatment with antibiotics reduced such increases in LPS endotoxins and ameliorated alcoholic liver injury in animals (Uesugi 2001, Nanji 1994, Adachi

1995). Activation of Kupffer cells by LPS endotoxins involves CD14, toll-like receptor 4 (TLR4), and MD2 (Uesugi 2001, Akira 2001, Yin 2001). The downstream pathways of TLR4 signalling include activation of early growth response 1 (EGR1), NF $\kappa$ B, and the TLR4 adapter also called toll-interleukin-1 receptor domain-containing adapter inducing interferon- $\beta$  (TRIF) (McCuillen 2005, Zhao 2008). TRIF-dependent signalling may contribute to alcohol-induced liver damage mediated by TLR4 (Hritz 2008).

Many animal studies have shown that alcohol ingestion increases various markers of oxidative stress (Meagher 1999, Wu2009). Studies in rats and mice suggest that activated macrophages (Kupffer cells) and hepatocytes are the main sources of alcohol-induced free radicals (Bailey 1998, Kamimura 1992). Oxidative stress may mediate alcohol-induced liver injury, e.g., via cytochrome P450 2E1 (Mansuri 1999, Lu 2008), leading to mitochondrial damage, activation of endoplasmic reticulum-dependent apoptosis, and up-regulation of lipid synthesis (Ji 2003, Yin 2001). Activated Kupffer cells will also release TNF- $\alpha$ ; this cytokine plays an important role in the pathogenesis of alcoholic hepatitis. Circulating TNF- $\alpha$  concentrations are higher in patients with alcoholic hepatitis than in heavy drinkers with inactive cirrhosis, heavy drinkers who do not have liver disease and persons who do not drink alcohol and who do not have liver disease (Adachi 1994, Bird 1990). Circulating TNF- $\alpha$  concentrations are associated with high mortality (Bird 1990). In animal studies, knockouts of the TNF receptor 1 and administration of the anti-TNF agent thalidomide both ameliorated alcohol-induced liver injury (Yin 1999, Imuro 1997, Enomoto 2002). Ethanol was also shown to release mitochondrial cytochrome c and to induce expression of the Fas ligand which may then cause apoptosis via the caspase-3 activation pathway (Zhou 2001). Both TNF- and Fas-mediated signals may increase the vulnerability of hepatocytes (Minagawa 2004).

## Treatment

### Abstinence from alcohol

After recovery from liver failure all patients with alcoholic hepatitis patients need to have psychological and social support in order to assure continued abstinence (Saitz 2007).

### Supportive therapy

There is still a lack of specific therapy for patients with alcoholic hepatitis although prednisolone and pentoxifylline may have beneficial effects in severe disease. It is, however, generally accepted that all complications and risks such as ascites, encephalopathy, hepatorenal syndrome, and infections should be treated like other decompensated liver diseases (Kosten 2003, Sanyal 2008, Lim 2008). The daily protein intake should be at least 1.5 g/kg. Vitamin B1 and other vitamins should be administered according to recommended references (Barr 2006).

### Corticosteroids

Various studies and meta-analyses show controversial results for the use of corticosteroids in alcoholic hepatitis (Imperiale 1990, Christensen 1999, Imperiale 1999, Rambaldi 2008). In general, corticosteroids have not been shown to increase survival, in particular during longer follow-up (Rambaldi 2008). However, there is

evidence that corticosteroids do reduce mortality in a subgroup of patients with a Maddrey's discriminant function  $>32$  or in those presenting with hepatic encephalopathy (Rambaldi 2008). A meta-analysis of three studies corroborated that corticosteroids given for 28 days increase 1-month survival by 20% in severe alcoholic hepatitis (Maddrey's discriminant function  $>32$ ) (Mathurin 2002). In these studies Maddrey's discriminant function  $>32$  resembled a MELD score of  $>21$ . In most studies prednisolone was given at 40 mg a day for 28 days. In some studies prednisolone was stopped completely at 28 days (Mathurin 2003), while the dose was gradually reduced in other studies (Imperiale 1990). Corticoids should not be given in the presence of sepsis, severe infection, hepatorenal syndrome, chronic hepatitis B, or gastrointestinal bleeding (O'Shea 2006).

The mechanisms by which corticosteroids improve short-term survival in severe alcoholic hepatitis are not fully understood. In general, corticosteroids inhibit various inflammatory processes by acting on activator protein 1 and NF $\kappa$ B (Barnes 1997). In some studies in patients with alcoholic hepatitis, the administration of corticosteroids was associated with a decrease in circulating levels of proinflammatory cytokines such as interleukin-8, TNF- $\alpha$  and others (Taieb 2000, Spahr 2001).

Recent reviews and recommendations conclude that corticosteroids should not be given to patients with a Maddrey's discriminant function  $<32$  or a MELD score  $<21$  until further data can identify patients with a high short-term risk (Lucey 2009). Corticosteroids are thus ineffective in a large group of patients with alcoholic hepatitis and probably do not affect long-term outcome. There is also evidence that corticosteroids can be discontinued after 7 days if there is no obvious improvement in clinical signs and symptoms and in serum bilirubin (Maddrey 1978, Dunn 2005, Forrest 2005, Louvet 2007).

## Pentoxifylline

Pentoxifylline (400 mg TID for 28 days) reduced short-term mortality in severe alcoholic hepatitis (Maddrey's discriminant function  $>32$ ) in a randomized, controlled trial; mortality was 24% in the pentoxifylline group and 46% in the placebo group ( $p<0.01$ ) (Akrivadis 2000). This trial did not include a group on corticosteroid treatment. Although the phosphodiesterase inhibitor pentoxifylline has been suggested to act as an anti-TNF agent, TNF- $\alpha$  concentrations did not differ significantly between the two groups. Thus, the mechanisms by which pentoxifylline may improve the prognosis in alcoholic hepatitis remains unknown. Interestingly, almost all deaths (22 of 24; 92%) in the placebo group were associated with hepatorenal syndrome while hepatorenal syndrome was considered the cause of death in only 6 of 12 patients (50%) in the pentoxifylline group. Thus, one might speculate that pentoxifylline may exert its beneficial effects by preventing the development of hepatorenal syndrome. A recent study (De BK 2009) compared the efficacy of pentoxifylline and prednisolone in the treatment of severe alcoholic hepatitis. 68 patients with severe alcoholic hepatitis (Maddrey score  $>32$ ) received pentoxifylline (400 mg TID for 28 days) ( $n=34$ ) or prednisolone (40 mg QD for 28 days) ( $n=34$ ) for 28 days in a randomized double-blind controlled study, and subsequently in an open-label study (with a tapering dose of prednisolone) for a total of 3 months, and were followed over a period of 12 months. Twelve patients in the corticosteroid group died by the end of month 3 in contrast to five patients in the



pentoxifylline group (mortality 35.3% vs 14.7%,  $p=0.04$ ). Six patients in the corticosteroid group but none in the pentoxifylline group developed hepatorenal syndrome. Pentoxifylline was associated with a significantly lower MELD score at the end of 28 days of therapy when compared to corticosteroids ( $15.5 \pm 3.6$  vs  $17.8 \pm 4.6$ ,  $p=0.04$ ). Reduced mortality, improved risk:benefit profile and renoprotective effects of pentoxifylline compared with prednisolone suggest that pentoxifylline is superior to prednisolone for treatment of severe alcoholic hepatitis. Interestingly, another recent study showed that long-term pentoxifylline therapy effectively achieved sustained biochemical improvement and even histological improvement in non-alcoholic steatohepatitis (Satapathy 2007).

## **N-acetyl cysteine**

A multicentre, randomised, controlled trial (Nguyen-Khac 2009) analysed treatment of severe acute alcoholic hepatitis via corticoids plus N-acetyl cysteine (C+NAC) versus corticoids (C) alone. The background to this approach was the hypothesis that the glutathione precursor NAC may rebuild antioxidant stocks in the hepatocyte. Deaths were significantly lower in the C+NAC group than in the C group at month 1 ( $n=7/85$  (8.2%) vs.  $21/89$  (23.6%),  $p=0.005$ ) and at month 2 ( $13/85$  (15.3%) vs.  $29/89$  (32.6%),  $p=0.007$ ) but not at month 3 ( $19/85$  (22.4%) vs.  $30/89$  (33.7%),  $p=0.095$ ) or at month 6 ( $23/85$  (27.1%) vs.  $34/89$  (38.2%). NAC may improve short-term survival. This improvement, however, is lost by month 3.

## **Anti-TNF- $\alpha$ therapy**

Some smaller studies have shown beneficial results using the TNF- $\alpha$  receptor antagonists infliximab and etanercept in patients with acute alcoholic hepatitis (Spahr 2007, Mookerjee 2003, Tilg 2003, Menin 2004). A larger randomized, controlled clinical trial compared the effects of infliximab plus prednisolone vs placebo plus prednisolone in patients with severe alcoholic hepatitis (Maddrey's discriminant function  $>32$ ) (Naveau 2004). The trial was stopped early by the safety monitoring board because of a significant increase in severe infections and a (nonsignificant) increase in deaths in the infliximab group. Similarly, etanercept reduced 6-month survival when compared with placebo in a randomized, placebo-controlled trial (Boetticher 2008). Thus, TNF- $\alpha$  receptor antagonists should not be used for clinical therapy of alcoholic hepatitis (Lucey 2009).

## **Nutritional support**

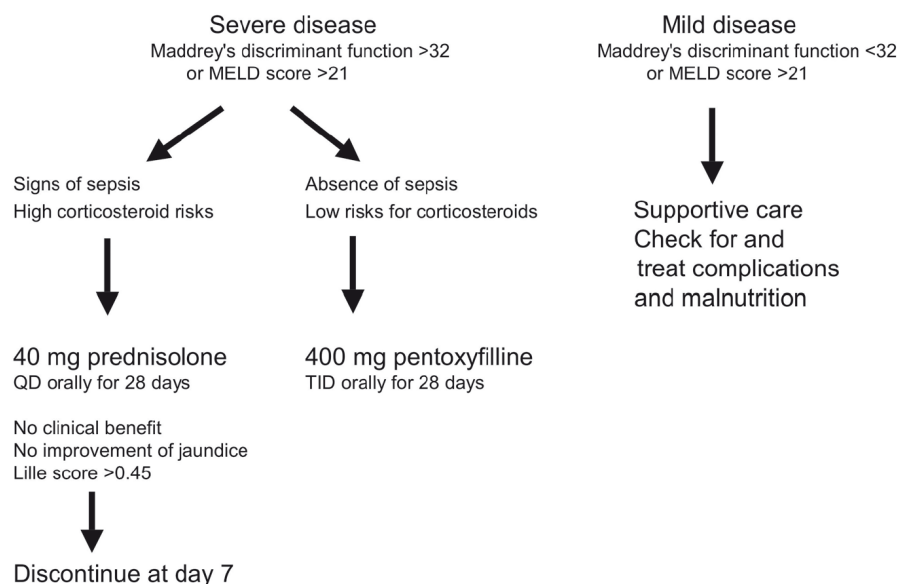
Many patients with alcoholic hepatitis have signs of malnutrition associated with high mortality (Mendenhall 1984, Mendenhall 1986, Stickel 2003). Parenteral and enteral nutrition have been shown to improve malnutrition in alcoholic hepatitis but has not improved survival (Mendenhall 1984). A randomised, controlled clinical trial looked at the effects of enteral nutrition of 2000 kcal/day via tube feeding versus treatment with 40 mg/day prednisolone for 28 days in severe alcoholic hepatitis. Survival in both groups was similar after one month and one year. It may be concluded that nutritional support is as effective as corticosteroids in some patients (Cabre 2000). However, corticoids in many studies failed to improve long-term survival.

## Other pharmacologic treatments

The anabolic steroid oxandrolone failed to improve survival in patients with alcoholic hepatitis (Mendenhall 1984). Numerous studies have shown that alcoholic hepatitis is accompanied by oxidative stress. So far, all studies with antioxidants such as vitamin E, silymarin (milk thistle) and others have failed to improve survival in alcoholic hepatitis (Pares 1998, Mezey 2004). Older studies did show that colchicine, propylthiouracil, insulin and glucagon failed to improve survival in alcoholic hepatitis (Lucey 2009).

## Liver transplantation

In current guidelines for liver transplantation, the patient needs to have at least a 6-month period of alcohol abstinence before they can be evaluated for transplantation, thus alcoholic hepatitis is usually a contraindication for liver transplantation (Lucey 1997, Everhardt 1997, Lucey 2007).



**Figure 6.** Treatment algorithm in alcoholic hepatitis.

## Summary

Alcoholic hepatitis is a clinical diagnosis based on a history of heavy alcohol consumption, jaundice, other signs of liver failure, and the absence of other causes of hepatitis. A liver biopsy may be helpful but is not required either to determine the diagnosis or prognosis. Abstinence from alcohol is the prerequisite for recovery. Patients with signs of malnutrition should have adequate nutritional support. Subjects with severe alcoholic hepatitis (Maddrey's discriminant function  $>32$  or MELD score  $>21$ ) who do not have sepsis or other corticosteroid contraindications

may receive 40 mg prednisolone daily for 28 days (McCullough 1998, Lucey 2009). A treatment algorithm is shown in Figure 6. After 7 days of corticosteroid treatment, patients without obvious clinical benefit, without significant improvement of jaundice and with a Lille score  $>0.45$  may have disease that will not respond to continued treatment with corticosteroids or an early switch to pentoxifylline (Louvet 2008). In situations where administration of corticosteroids appears to be risky, pentoxifylline may be tried (Lucey 2009); this drug may decrease the risk of hepatorenal syndrome that is often lethal in alcoholic hepatitis. Patients with less severe alcoholic hepatitis have a good short-term survival of  $>90\%$  and should not be treated with corticosteroids or pentoxifylline (Mathurin 2002).

## References

- Agarwal K, Czaja AJ, Jones De, et al. Cytotoxic T lymphocyte antigen-4 (CTLA-4) gene polymorphisms and susceptibility to type 1 autoimmune hepatitis. *Hepatology* 2000;31:49-53. (Abstract)
- Ahmed M, Mutimer D, Hathaway M, et al. Liver transplantation for autoimmune hepatitis: a 12-year experience. *Transplant. Proc.* 1997;29:496. (Abstract)
- Alvarez F, Berg PA, Bianchi FB, et al. International Autoimmune Hepatitis Group Report: review of criteria for diagnosis of autoimmune hepatitis. *J. Hepatology* 1999;31:929-38. (Abstract)
- Alvarez F, Ciocca M, Canero-Velasco C, et al. Short-term cyclosporine induces a remission of autoimmune hepatitis in children. *J. Hepatol.* 1999;30:222-7. (Abstract)
- Angulo P, Smith C, Jorgensen RA. Budesonide in the treatment of patients with primary biliary cirrhosis with suboptimal response to ursodeoxycholic acid. *Hepatology* 2000;20:471-90.
- Bach N, Bodian C, Bodenheimer H, et al. Methotrexate therapy for primary biliary cirrhosis. *Am J Gastroenterol* 2003;98:187-93. (Abstract)
- Bandin O, Courvalin Jc, Poupon R, et al. Specificity and sensitivity of gp210 autoantibodies detected using an enzyme-linked immunosorbent assay and a synthetic polypeptide in the diagnosis of primary biliary cirrhosis. *Hepatology* 1996;23:1020-4. (Abstract)
- Beaune Ph, Lecoeur S, Bourdi M, et al. Anti-cytochrome P450 autoantibodies in drug-induced disease. *Eur J Haematol Suppl* 1996;60:89-92. (Abstract)
- Berg PA, Doniach D, Roitt IM. Mitochondrial antibodies in primary biliary cirrhosis. I. Localization of the antigen to mitochondrial membranes. *J Exp Med* 1967;126:277-90. (Abstract)
- Berg PA, Klein R. Mitochondrial antigen/antibody systems in primary biliary cirrhosis: revisited. *Liver* 1995;15:281-92. (Abstract)
- Berg PA, Klein R. Mitochondrial antigens and autoantibodies: from anti-M1 to anti-M9. *Klin Wochenschr* 1986;64:897-909. (Abstract)
- Bergquist A, Broome U. Hepatobiliary and extra-hepatic malignancies in primary sclerosing cholangitis. *Best Pract Res Clin Gastroenterol* 2001;15:643-56. (Abstract)
- Bergquist A, Ekbohm A, Olsson R, et al. Hepatic and extrahepatic malignancies in primary sclerosing cholangitis. *J Hepatol* 2002;36:321-7. (Abstract)
- Beuers U, Rust C. Overlap syndromes. *Semin Liver Dis* 2005;25:311-20. (Abstract)
- Bloch DB, Chiche JD, Orth D, et al. Structural and functional heterogeneity of nuclear bodies. *Mol Cell Biol* 1999;19:4423-30. (Abstract)
- Bluthner M, Schafer C, Schneider C, et al. Identification of major linear epitopes on the sp100 nuclear PBC autoantigen by the gene-fragment phage-display technology. *Autoimmunity* 1999;29:33-42. (Abstract)
- Boberg KM, Aadland E, Jahnsen J, et al. Incidence and prevalence of primary biliary cirrhosis, primary sclerosing cholangitis, and autoimmune hepatitis in a Norwegian population. *Scand. J. Gastroenterol.* 1998;33:99-103. (Abstract)
- Boberg KM, Bergquist A, Mitchell S, et al. Cholangiocarcinoma in primary sclerosing cholangitis: risk factors and clinical presentation. *Scand J Gastroenterol* 2002;37:1205-11. (Abstract)

## 500 Hepatology 2012

- Boberg KM, Fausa O, Haaland T, et al. Features of autoimmune hepatitis in primary sclerosing cholangitis: an evaluation of 114 primary sclerosing cholangitis patients according to a scoring system for the diagnosis of autoimmune hepatitis. *Hepatology* 1996;23:1369-76. ([Abstract](#))
- Bodenheimer Jr H, Schaffner F, Pezzullo J. Evaluation of colchicine therapy in primary biliary cirrhosis. *Gastroenterology* 1998;95:124-9. ([Abstract](#))
- Bodenheimer Jr HC, Schaffner F, Sternlieb I, et al. A prospective clinical trial of D-penicillamine in the treatment of primary biliary cirrhosis. *Hepatology* 1985;5:1139-42. ([Abstract](#))
- Broome U, Glaumann H, Lindstom E, et al. Natural history and outcome in 32 Swedish patients with small duct primary sclerosing cholangitis (PSC). *J Hepatol* 2002;36:586-9. ([Abstract](#))
- Broome UO, Loof R, Bodemar L, Hultcrantz G, Danielsson R, Prytz A, et al. Natural history and prognostic factors in 305 Swedish patients with primary sclerosing cholangitis. *Gut* 1996;38:610-5. ([Abstract](#))
- Calmus Y, Gane P, Rouger P, et al. Hepatic expression of class I and class II major histocompatibility complex molecules in primary biliary cirrhosis: effect of ursodeoxycholic acid. *Hepatology* 1990;11:12-5. ([Abstract](#))
- Cancado Elr, Porta G. *Autoimmune hepatitis in South America*. 2000; Kluwer Academic Publishers, Dordrecht, Boston, London.
- Chen W, Gluud C. Bile acids for primary sclerosing cholangitis. *Cochrane Database Syst Rev* 2003;CD003626. ([Abstract](#))
- Christensen E, Neuberger J, Crowe J, et al. Beneficial effect of azathioprine and prediction of prognosis in primary biliary cirrhosis. Final results of an international trial. *Gastroenterology* 1985;89:1084-91. ([Abstract](#))
- Crivelli O, Lavarini C, Chiaberge E, et al. Microsomal autoantibodies in chronic infection with HBsAg associated delta (delta) agent. *Clin. Exp. Immunol.* 1983;54:232-8. ([Abstract](#))
- Czaja AJ. Frequency and nature of the variant syndromes of autoimmune liver disease. *Hepatology* 1998;28:360-5. ([Abstract](#))
- Czaja AJ, Carpenter HA, Santrach PJ, et al. Evidence against hepatitis viruses as important causes of severe autoimmune hepatitis in the United States. *J. Hepatol.* 1993;18:342-52. ([Abstract](#))
- Czaja AJ, Carpenter HA, Lindor KD. Ursodeoxycholic acid as adjunctive therapy for problematic type 1 autoimmune hepatitis: a randomized placebo-controlled treatment trial. *Hepatology* 1999;30:1381-6. ([Abstract](#))
- Czaja AJ, Lindor KD. Failure of budesonide in a pilot study of treatment-dependent autoimmune hepatitis. *Gastroenterology* 2000;119:1312-6. ([Abstract](#))
- Dalekos GN, Wedemeyer H, Obermayer-Straub P, et al. Epitope mapping of cytochrome P450D6 autoantigen in patients with chronic hepatitis C during alpha-interferon treatment. *J Hepatol* 1999;30:366-75. ([Abstract](#))
- Danielson A, Prytz H. Oral budesonide for treatment of autoimmune chronic hepatitis. *Aliment. Pharmacol. Ther.* 1994;8:585-90. ([Abstract](#))
- Davis Pa, Leung P, Manns M, et al. M4 and M9 antibodies in the overlap syndrome of primary biliary cirrhosis and chronic active hepatitis: epitopes or epiphenomena? *Hepatology* 1992;16:1128-36. ([Abstract](#))
- De BK, Gangopadhyay S, Dutta D, Baksi SD, Pani A, Ghosh P. *World J Gastroenterol* 2009;15:1613-9. ([Abstract](#))
- Debray D, Maggiore G, Giradet JP, et al. Efficacy of cyclosporin A in children with type 2 autoimmune hepatitis. *J. Pediatr* 1999;135:111-4. ([Abstract](#))
- Devlin J, Donaldson P, Portman B, et al. Recurrence of autoimmune hepatitis following liver transplantation. *Liver Transpl Surg* 1995;1:162-5. ([Abstract](#))
- Dickson ER, Murtaugh PA, Wiesner RH, et al. Primary sclerosing cholangitis: refinement and validation of survival models. *Gastroenterology* 1992;103:1893-1901. ([Abstract](#))
- Dienes HP, Popper H, Manns M, et al. Histologic features in autoimmune hepatitis. *Z Gastroenterol* 1989;27:327-30. ([Abstract](#))
- Dighiero G, Lymberi P, Monot C, et al. Sera with high levels of anti-smooth muscle and anti-mitochondrial antibodies frequently bind to cytoskeleton proteins. *Clin Exp Immunol* 1990;82:52-6. ([Abstract](#))
- Doherty DG, Donaldson PT, Underhill JA, et al. Allelic sequence variation in the HLA class II genes and proteins on patients with autoimmune hepatitis. *Hepatology* 1994;19:609-15. ([Abstract](#))

- Donaldson PT. Immunogenetics in liver disease. *Baillieres Clin Gastroenterol* 1996;10:533-49 (Abstract)
- Donaldson PT. TNF gene polymorphisms in primary biliary cirrhosis: a critical appraisal [editorial; comment]. *J Hepatol* 1999;31:366-8. (Abstract)
- Donaldson PT, Czaja AJ. Genetic effects on susceptibility, clinical expression, and treatment outcome of type 1 autoimmune hepatitis. *Clin Liver Dis* 2002;6:419-37. (Abstract)
- Donaldson PT, Doherty DG, Hayllar KM, et al. Susceptibility to autoimmune chronic active hepatitis: human leukocyte antigens DR 4 and A1-B8-DR-3 are independent risk factors. *Hepatology* 1991;13:701-6. (Abstract)
- Dubel L, Farges O, Courvalin JC, et al. Persistence of gp210 and multiple nuclear dots antibodies does not correlate with recurrence of primary biliary cirrhosis 6 years after liver transplantation. *J Hepatol* 1998;28:169-70. (Abstract)
- Durazzo M, Philipp T, Van Pelt FN, et al. Heterogeneity of liver-kidney microsomal autoantibodies in chronic hepatitis C and D virus infection. *Gastroenterology* 1995;108:455-62. (Abstract)
- Farrant JM, Hayllar KM, Wilkinson MI, et al. Natural history and prognostic variables in primary sclerosing cholangitis. *Gastroenterology* 1991;100:1710-7. (Abstract)
- Fernandez NF, Redeker AG, Vierling JM, et al. Cyclosporine therapy in patients with steroid resistant autoimmune hepatitis. *Am. J. Gastroenterol.* 1999;94:241-8. (Abstract)
- Frazer IH, Mackay IR, Jordan TW, et al. Reactivity of anti-mitochondrial autoantibodies in primary biliary cirrhosis: definition of two novel mitochondrial polypeptide autoantigens. *J Immunol* 1985;135:1739-45. (Abstract)
- Fujimoto M, Sato S, Ihn H, et al. Autoantibodies to pyruvate dehydrogenase complex in patients with systemic sclerosis. Possible role of anti-E1 alpha antibody as a serologic indicator for development of primary biliary cirrhosis. *Arthritis Rheum* 1995;38:985-9. (Abstract)
- Geall MG, Schoenfield LJ, Summerskill WHJ. Classification and treatment of chronic active liver disease. *Gastroenterology* 1968;55:724-9. (Abstract)
- Gelpi CSE, Rodriguez-Sanchez JL. Autoantibodies against a serine tRNA-protein complex implicated in cotranslational selenocysteine insertion. *Proc Natl Acad Sci US* 1992;89:9739-43. (Abstract)
- Gershwin ME, Mackay IR. Primary biliary cirrhosis: paradigm or paradox for autoimmunity. *Gastroenterology* 1991;100:822-33. (Abstract)
- Gershwin ME, Mackay IR, Sturgess A, et al. Identification and specificity of a cDNA encoding the 70 kd mitochondrial antigen recognized in primary biliary cirrhosis. *J Immunol* 1987;138:3525-31. (Abstract)
- Gordon MA, Oppenheim E, Camp NJ, et al. Primary biliary cirrhosis shows association with genetic polymorphism of tumour necrosis factor alpha promoter region [see comments]. *J Hepatol* 1999;31:242-. (Abstract)
- Götz G, Neuhaus R, Bechstein WO, et al. Recurrence of autoimmune hepatitis after liver transplantation. *Transplant. Proc.* 1999;31:430-1. (Abstract)
- Goulis J, Leandro G, Burroughs AK. Randomised controlled trials of ursodeoxycholic acid therapy for primary biliary cirrhosis: a meta analysis. *Lancet* 1999;354:1053-60. (Abstract)
- Gouw AS, Haagsma EB, Manns M, et al. Is there recurrence of primary biliary cirrhosis after liver transplantation? A clinicopathologic study in long-term survivors. *J Hepatol* 1994;20:500-7. (Abstract)
- Graziadei IW, Wiesner RH, Batts KP, et al. Recurrence of primary sclerosing cholangitis following liver transplantation. *Hepatology* 1999;29:1050-6. (Abstract)
- Gregorio Gv, Portman B, Reid F, et al. Autoimmune hepatitis in childhood: a 20-year experience. *Hepatology* 1997;25:541-7. (Abstract)
- Guenguen M, Boniface O, Bernard O, et al. Identification of the main epitope on human cytochrome P450IID6 recognized by anti-liver kidney microsome antibody. *J. Autoimmun.* 1991;4:607-15. (Abstract)
- Guenguen M, Meunier-Rotival M, Bernard O, et al. Anti-liver-kidney microsome antibody recognizes a cytochrome P450 from the IID subfamily. *J. Exp. Med.* 1988;168:801 (Abstract)
- Haagsma EB. Clinical relevance of recurrence of primary biliary cirrhosis after liver transplantation. *Eur J Gastroenterol Hepatol* 1999;11:639-42. (Abstract)

## 502 Hepatology 2012

- Haagsma EB, Manns M, Klein R, et al. Subtypes of antimitochondrial antibodies in primary biliary cirrhosis before and after orthotopic liver transplantation. *Hepatology* 1987;7:129-33. ([Abstract](#))
- Harnois DM, Angulo P, Jorgensen RA, et al. High-dose ursodeoxycholic acid as a therapy for patients with primary sclerosing cholangitis. *Am J Gastroenterol* 2001;96:1558-62. ([Abstract](#))
- Hendrickse MT, Rigney E, Gjaffer MH, et al. Low-dose methotrexate is ineffective in primary biliary cirrhosis: long-term results of a placebo-controlled trial. *Gastroenterology* 1999;117:400-7. ([Abstract](#))
- Heneghan MA, Mcfarlane IG. Current and novel immunosuppressive therapy for autoimmune hepatitis. *Hepatology* 2002;35:7-13. ([Abstract](#))
- Homborg JC, Abuaf N, Bernard O, et al. Chronic active hepatitis associated with anti liver/kidney microsome type 1: a second type of "autoimmune" hepatitis. *Hepatology* 1987;7:1333-9. ([Abstract](#))
- Ikeda T, Tozuka S, Noguchi O. Effects of additional administration of colchicine in ursodeoxycholic acid-treated patients with primary biliary cirrhosis: a prospective randomized study. *J Hepatol* 1996;24:88-94. ([Abstract](#))
- Ishii H, Saifuku K, Namihisa T. Multiplicity of mitochondrial inner membrane antigens from beef heart reacting with antimitochondrial antibodies in sera of patients with primary biliary cirrhosis. *Immunol Lett* 1985;9:325-30. ([Abstract](#))
- Johnson PJ, Mcfarlane IG. Meeting report: International autoimmune hepatitis group. *Hepatology* 1993;18:998-1005. ([Abstract](#))
- Johnson PJ, Mcfarlane IG, Williams R. Azathioprine for long-term maintenance of remission in autoimmune hepatitis. *N. Engl. J. Med.* 1995;333:958-63. ([Abstract](#))
- Jones DE, Watt FE, Metcalf JV, et al. Familial primary biliary cirrhosis reassessed: a geographically-based population study. *J Hepatol* 1999;30:402-7. ([Abstract](#))
- Joplin R, Wallace LJ, Johnson GD, et al. Subcellular localization of pyruvate dehydrogenase dihydrolipoamide acetyltransferase in human intrahepatic biliary epithelial cells. *J Pathol* 1995;176:381-90. ([Abstract](#))
- Joplin RE, Neuberger JM. Immunopathology of primary biliary cirrhosis. *Eur J Gastroenterol Hepatol* 1999;11:587-93. ([Abstract](#))
- Kanzler S, Gerken G, Dienes HP, et al. Cyclophosphamide as alternative immunosuppressive therapy for autoimmune hepatitis - report of three cases. *Z. Gastroenterol.* 1996;35:571-8. ([Abstract](#))
- Kaplan MM, Alling DW, Zimmerman HJ, et al. A prospective trial of colchicine for primary biliary cirrhosis. *N Engl J Med* 1986;315:1448-54. ([Abstract](#))
- Kato Y, Suzuki K, Kumagai M, et al. Familial primary biliary cirrhosis. Immunological and genetic study. *Am J Gastroenterol* 1981;75:188-91. ([Abstract](#))
- Kerkar N, Hadzic N, Davies ET, et al. De-novo autoimmune hepatitis after liver transplantation. *Lancet* 1998;351:409-413. ([Abstract](#))
- Kim WR, Therneau TM, Wiesner RH, et al. A revised natural history model for primary sclerosing cholangitis. *Mayo Clin Proc* 2000;75:688-94. ([Abstract](#))
- Kirk AP, Jain S, Pocock S, et al. Late results of the Royal Free Hospital prospective controlled trial of prednisolone therapy in hepatitis B surface antigen negative chronic active hepatitis. *Gut* 1980;21:789-93. ([Abstract](#))
- Klein R, Berg, PA. Anti-M4 antibodies in primary biliary cirrhosis react with sulphite oxidase, an enzyme of the mitochondrial inter-membrane space. *Clin Exp Immunol* 1991;84:445-8. ([Abstract](#))
- Klein R, Kloppel G, Garbe W, et al. Antimitochondrial antibody profiles determined at early stages of primary biliary cirrhosis differentiate between a benign and a progressive course of the disease. A retrospective analysis of 76 patients over 6-18 years. *J Hepatol* 1991;12:21-7.
- Klein R, Pointner H, Zilly W, et al. Antimitochondrial antibody profiles in primary biliary cirrhosis distinguish at early stages between a benign and a progressive course: a prospective study on 200 patients followed for 10 years. *Liver* 1997;17:119-28. ([Abstract](#))
- Kurki P, Miettinen A, Linder E, et al. Different types of smooth muscle antibodies in chronic active hepatitis and primary biliary cirrhosis: their diagnostic and prognostic significance. *Gut* 1980;21:878-84. ([Abstract](#))
- Lankisch TO, Strassburg CP, Debray D, et al. Detection of autoimmune regulator gene mutations in children with type 2 autoimmune hepatitis and extrahepatic immune-mediated diseases. *J Pediatr* 2005;146:839-42. ([Abstract](#))

- Larusso NF, Shneider BL, Black D, et al. Primary sclerosing cholangitis: summary of a workshop. *Hepatology* 2006;44:746-64. ([Abstract](#))
- Lassoued K, Brenard R, Degos F, et al. Antinuclear antibodies directed to a 200-kilodalton polypeptide of the nuclear envelope in primary biliary cirrhosis. A clinical and immunological study of a series of 150 patients with primary biliary cirrhosis. *Gastroenterology* 1990;99:181-6 ([Abstract](#))
- Lenzi M, Manotti P, Muratori L, et al. Liver cytosolic 1 antigen-antibody system in type 2 autoimmune hepatitis and hepatitis C virus infection. *Gut* 1995;36:749-54. ([Abstract](#))
- Leung PS, Chuang DT, Wynn RM, et al. Autoantibodies to BCOADC-E2 in patients with primary biliary cirrhosis recognize a conformational epitope. *Hepatology* 1995;22:505-13. ([Abstract](#))
- Leung PS, Van De Water J, Coppel RI, et al. Molecular aspects and the pathological basis of primary biliary cirrhosis. *J Autoimmun* 1996;9:119-28. ([Abstract](#))
- Leuschner M, Guldutuna S, You T, et al. Ursodeoxycholic acid and prednisolone versus ursodeoxycholic acid and placebo in the treatment of early stages of primary biliary cirrhosis. *J Hepatol* 1996;25:49-57. ([Abstract](#))
- Leuschner M, Holtmeier J, Ackermann H, et al. The influence of sulindac on patients with primary biliary cirrhosis that responds incompletely to ursodeoxycholic acid: a pilot study. *Eur J Gastroenterol Hepatol* 2002;14:1369-76. ([Abstract](#))
- Leuschner M, Maier KP, Schlichting J, et al. Oral budesonide and ursodeoxycholic acid for treatment of primary biliary cirrhosis: results of a prospective double-blind trial. *Gastroenterology* 1999;117:918-25. ([Abstract](#))
- Lidman K, Biberfeld G, Fagraeus A, et al. Anti-actin specificity of human smooth muscle antibodies in chronic active hepatitis. *Clin Exp Immunol* 1976;24:266-72. ([Abstract](#))
- Lin F, Noyer Cm, Ye Q, et al. Autoantibodies from patients with primary biliary cirrhosis recognize a region within the nucleoplasmic domain of inner nuclear membrane protein LBR. *Hepatology* 1996;23:57-61. ([Abstract](#))
- Lindenborn-Fotinos J, Baum H, Berg PA. Mitochondrial antibodies in primary biliary cirrhosis: species and nonspecies specific determinants of M2 antigen. *Hepatology* 1985;5:763-9. ([Abstract](#))
- Lohr H, Fleischer B, Gerken G, et al. Autoreactive liver-infiltrating T cells in primary biliary cirrhosis recognize inner mitochondrial epitopes and the pyruvate dehydrogenase complex. *J Hepatol* 1993;18:322-7. ([Abstract](#))
- Lombard M, Portmann B, Neuberger J, et al. Cyclosporin A treatment in primary biliary cirrhosis: results of a long-term placebo controlled trial. *Gastroenterology* 1993;104:519-26. ([Abstract](#))
- Luettig B, Boeker KH, Schoessler W, et al. The antinuclear autoantibodies Sp100 and gp210 persist after orthotopic liver transplantation in patients with primary biliary cirrhosis. *J Hepatol* 1998;28:824-8. ([Abstract](#))
- Mackay I, R, Taft LI, Cowling DC. Lupoid hepatitis. *Lancet* 1956;2:1323-6. ([Abstract](#))
- Mackay IR. Primary biliary cirrhosis showing a high titer of autoantibody. *N. Engl. J. Med.* 1958;258:707-13. ([Abstract](#))
- Mackay IR, Gershwin ME. The nature of autoimmune disease. *Semin Liver Dis* 1997;17:3-11. ([Abstract](#))
- Mackay IR, Morris PJ. Association of autoimmune chronic hepatitis with HLA-A1-B8. *Lancet* 1972;2:793-5. ([Abstract](#))
- Mackay IR, Tait BD. HLA association with autoimmune type chronic active hepatitis: identification of B8-DRw3 haplotype by family studies. *Gastroenterology* 1980;79:95-8. ([Abstract](#))
- Manns M, Gerken G, Kyriatsoulis A, et al. Characterisation of a new subgroup of autoimmune chronic active hepatitis by autoantibodies against a soluble liver antigen. *Lancet* 1987;1:292-4. ([Abstract](#))
- Manns M, Gerken G, Trautwein C, et al. Characterization of primary biliary cirrhosis (PBC) specific mitochondrial determinants by immunoblotting. *Dtsch Z Verdau Stoffwechselkr* 1987;47:59-66. ([Abstract](#))
- Manns M, Meyer Zum Buschenfelde KH. A mitochondrial antigen-antibody system in cholestatic liver disease detected by radioimmunoassay. *Hepatology* 1982;2:1-7. ([Abstract](#))
- Manns M, Meyer Zum BÜschenfelde KH, Slusarczyk J, et al. Detection of liver-kidney microsomal autoantibodies by radioimmunoassay and their relation to

- antimitochondrial antibodies in inflammatory liver disease. *Clin. Exp. Immunol.* 1984;54:600-8. (Abstract)
- Manns MP, Bahr MJ. Recurrent autoimmune hepatitis after liver transplantation - when non-self becomes self. *Hepatology* 2000;32:868-70. (Abstract)
- Manns MP, Bremm A, Schneider PM, et al. HLA DRw8 and complement C4 deficiency as risk factors in primary biliary cirrhosis. *Gastroenterology* 1991;101:1367-73. (Abstract)
- Manns MP, Griffin KJ, Sullivan KF, et al. LKM-1 autoantibodies recognize a short linear sequence in P450IID6, a cytochrome P-450 monooxygenase. *J. Clin. Invest.* 1991;88:1370-8. (Abstract)
- Manns MP, Jentzsch M, Mergener K, et al. Discordant manifestation of LKM-1 antibody positive autoimmune hepatitis in identical twins. *Hepatology* 1990;12:840.
- Manns MP, Johnson EF, Griffin KJ, et al. Major antigen of liver kidney microsomal antibodies in idiopathic autoimmune hepatitis is cytochrome P450db1. *J. Clin. Invest.* 1998;83:1066-72. (Abstract)
- Manns MP, Kruger M. Immunogenetics of chronic liver diseases. *Gastroenterology* 1994;106:1676-97. (Abstract)
- Manns MP, Strassburg CP. Autoimmune hepatitis: clinical challenges. *Gastroenterology* 2001;120:1502-17. (Abstract)
- Mattalia A, Luttig B, Rosina F, et al. Persistence of autoantibodies against recombinant mitochondrial and nuclear pore proteins after orthotopic liver transplantation for primary biliary cirrhosis. *J Autoimmun* 1997;10:491-7. (Abstract)
- Mehal Wz, Gregory WI, Lo YM, et al. Defining the immunogenetic susceptibility to primary biliary cirrhosis. *Hepatology* 1994;20:1213-9. (Abstract)
- Milkiewicz P, Hubscher Sg, Skiba G et al. Recurrence of autoimmune hepatitis after liver transplantation. *Transplantation* 1999;68:253-6. (Abstract)
- Mitchell SA, Bansi DS, Hunt N, et al. A preliminary trial of high-dose ursodeoxycholic acid in primary sclerosing cholangitis. *Gastroenterology* 2001;121:900-7. (Abstract)
- Mitchison HC, Palmer JM, Bassendine MF, et al. A controlled trial of prednisolone treatment in primary biliary cirrhosis. Three-year results. *J Hepatol* 1992;15:336-44. (Abstract)
- Moteki S, Leung PS, Dickson ER, et al. Epitope mapping and reactivity of autoantibodies to the E2 component of 2-oxoglutarate dehydrogenase complex in primary biliary cirrhosis using recombinant 2-oxoglutarate dehydrogenase complex. *Hepatology* 1996;23:436-44. (Abstract)
- Muratori L, Cataleta M, Muratori P, et al. Detection of anti-liver cytosol antibody type 1 (anti-LC1) by immunodiffusion, counterimmunoelectrophoresis and immunoblotting: comparison of different techniques. *J. Immunol. Meth.* 1995;187:259-64. (Abstract)
- Muratori L, Sztul E, Muratori P, et al. Distinct epitopes on formiminotransferase cyclodeaminase induce autoimmune liver cytosol antibody type 1. *Hepatology* 2001;34:494-501. (Abstract)
- Nakamura K, Yoneda M, Yokohama S, et al. Efficacy of ursodeoxycholic acid in Japanese patients with type 1 autoimmune hepatitis [see comments]. *J Gastroenterol Hepatol* 1998;13:490-5. (Abstract)
- Neuberger J, Portmann B, Calne R, et al. Recurrence of autoimmune chronic active hepatitis following orthotopic liver grafting. *Transplantation* 1984;37:363-365. (Abstract)
- Newton JL, Burt AD, Park JB, et al. Autoimmune hepatitis in older patients. *Age Ageing* 1997;26:441-4. (Abstract)
- Nickowitz RE, Worman HJ. Autoantibodies from patients with primary biliary cirrhosis recognize a restricted region within the cytoplasmic tail of nuclear pore membrane glycoprotein Gp210. *J Exp Med* 1993;178:2237-42. (Abstract)
- Nickowitz RE, Wozniak RW, Schaffner F, et al. Autoantibodies against integral membrane proteins of the nuclear envelope in patients with primary biliary cirrhosis. *Gastroenterology* 1994;106:193-9. (Abstract)
- Nishio A, Van De Water J, Leung PS, et al. Comparative studies of antimitochondrial autoantibodies in sera and bile in primary biliary cirrhosis. *Hepatology* 1997;25:1085-9. (Abstract)
- Nishioka M, Morshed SA, Kono K, et al. Frequency and significance of antibodies to P450IID6 protein in Japanese patients with chronic hepatitis C. *J. Hepatol.* 1997;26:992-1000. (Abstract)
- Nishioka M, Morshed SA, Mcfarlane IG. Geographical variation in the frequency and characteristics of autoimmune liver diseases. Elsevier, Amsterdam. 1998.



- Notghi A, Nestle U, Rittner G, et al. Chromosomal aberrations in patients with primary biliary cirrhosis. *Hum Genet* 1990;85:546-50. ([Abstract](#))
- Obermayer-Straub P, Perheentupa J, Braun S, et al. Hepatic autoantigens in patients with autoimmune polyendocrinopathy-candidiasis-ectodermal dystrophy. *Gastroenterology* 2001;121:668-77. ([Abstract](#))
- Okolicsanyi L, Fabris L, Viaggi S, et al. Primary sclerosing cholangitis: clinical presentation, natural history and prognostic variables: an Italian multicentre study. The Italian PSC Study Group. *Eur J Gastroenterol Hepatol* 1996;8:685-91. ([Abstract](#))
- Olsson R, Boberg KM, De Muckadell OS, et al. High-dose ursodeoxycholic acid in primary sclerosing cholangitis: a 5-year multicenter, randomized, controlled study. *Gastroenterology* 2005;129:1464-72. ([Abstract](#))
- Onishi S, Sakamaki T, Maeda T, et al. DNA typing of HLA class II genes; DRB1\*0803 increases the susceptibility of Japanese to primary biliary cirrhosis. *J Hepatol* 1994;21:1053-60. ([Abstract](#))
- Ota M, Seki T, Kiyohawa K, et al. A possible association between basic amino acids of position 13 of DRB1 chains and autoimmune hepatitis. *Immunogenetics* 1992;36:40-55. ([Abstract](#))
- Palmer JM, Jones DE, Quinn J, et al. Characterization of the autoantibody responses to recombinant E3 binding protein (protein X) of pyruvate dehydrogenase in primary biliary cirrhosis. *Hepatology* 1999;30:21-6. ([Abstract](#))
- Palmer JM, Yeaman SJ, Bassendine MF, et al. M4 and M9 autoantigens in primary biliary cirrhosis--a negative study. *J Hepatol* 1993;18:251-4. ([Abstract](#))
- Pando M, Larriba J, Fernandez GC, et al. Pediatric and adult forms of type I autoimmune hepatitis in Argentina: evidence for differential genetic predisposition. *Hepatology* 1999;30:1374-80. ([Abstract](#))
- Pardi DS, Loftus Jr EV, Kremers WK, et al. Ursodeoxycholic acid as a chemopreventive agent in patients with ulcerative colitis and primary sclerosing cholangitis. *Gastroenterology* 2003;124:889-93. ([Abstract](#))
- Paumgartner G, Beuers U. Ursodeoxycholic acid in cholestatic liver disease: mechanisms of action and therapeutic use revisited. *Hepatology* 2002;36:525-31. ([Abstract](#))
- Philipp T, Durazzo M, Trautwein C, et al. Recognition of uridine diphosphate glucuronosyl transferases by LKM-3 antibodies in chronic hepatitis D. *Lancet* 1994;344:578-81. ([Abstract](#))
- Pitkanen J, Vahamurto P, Krohn K, et al. Subcellular localization of the autoimmune regulator protein. characterization of nuclear targeting and transcriptional activation domain. *J Biol Chem* 2001;276:19597-602. ([Abstract](#))
- Ponsioen CY, Vrouenraets SM, Prawirodirdjo W, et al. Natural history of primary sclerosing cholangitis and prognostic value of cholangiography in a Dutch population. *Gut* 2002;51:562-6. ([Abstract](#))
- Poupon RE, Huet PM, Poupon R, et al. A randomized trial comparing colchicine and ursodeoxycholic acid combination to ursodeoxycholic acid in primary biliary cirrhosis. UDCA-PBC Study Group. *Hepatology* 1996;24:1098-1103. ([Abstract](#))
- Poupon RE, Lindor KD, Cauch-Dudek K. Combined analysis of randomized controlled trials of ursodeoxycholic acid in primary biliary cirrhosis. *Gastroenterology* 1997;113:884-90 ([Abstract](#))
- Poupon RE, Lindor KD, Pares A, et al. Combined analysis of the effect of treatment with ursodeoxycholic acid on histologic progression in primary biliary cirrhosis. *J Hepatol* 2003;39:12-6. ([Abstract](#))
- Prados E, Cuervas-Mons V, De La Mata M, et al. Outcome of autoimmune hepatitis after liver transplantation. *Transplantation* 1998;66:1645-50. ([Abstract](#))
- Raedsch R, Stiehl A, Walker S, et al. Combined ursodeoxycholic acid plus colchicine--treatment of primary biliary cirrhosis: results of a placebo-controlled double-blind study. *Z Gastroenterol* 1992;30 Suppl 1:55-7. ([Abstract](#))
- Ramsey C, Winqvist O, Puhakka L, et al. Aire deficient mice develop multiple features of APECED phenotype and show altered immune response. *Hum Mol Genet* 2002;11:397-409. ([Abstract](#))
- Ratzl V, Samuel D, Sebagh M, et al. Long-term follow-up after liver transplantation for autoimmune hepatitis: evidence of recurrence of primary disease. *J Hepatol* 1999;30:131-41. ([Abstract](#))

- Rea DJ, Heimbach JK, Rosen CB, et al. Liver transplantation with neoadjuvant chemoradiation is more effective than resection for hilar cholangiocarcinoma. *Ann Surg* 2005;242:451-458; discussion 458-61. ([Abstract](#))
- Rebollo Bernardez J, Cifuentes Mimoso C, Pinar Moreno A, et al. Deflazacort for long-term maintenance of remission in type I autoimmune hepatitis. *Rev Esp Enferm Dig* 1999;91:630-8. ([Abstract](#))
- Reynoso-Paz S, Leung PS, Van De Water J, et al. Evidence for a locally driven mucosal response and the presence of mitochondrial antigens in saliva in primary biliary cirrhosis. *Hepatology* 2000;31:24-9. ([Abstract](#))
- Richardson PD, James PD, Ryder SD. Mycophenolate mofetil for maintenance of remission in autoimmune hepatitis in patients resistant to or intolerant of azathioprine. *J Hepatol* 2000;33:371-5. ([Abstract](#))
- Rizzetto M, Swana G, Doniach D. Microsomal antibodies in active chronic hepatitis and other disorders. *Clin. Exp. Immunol.* 1973;15:331-44. ([Abstract](#))
- Rost D, Rudolph G, Kloeters-Plachky P, et al. Effect of high-dose ursodeoxycholic acid on its biliary enrichment in primary sclerosing cholangitis. *Hepatology* 2004;40:693-8. ([Abstract](#))
- Sanchez-Urdazpal L, Czaja AJ, Van Holk B. Prognostic features and role of liver transplantation in severe corticoid-treated autoimmune chronic active hepatitis. *Hepatology* 1991;15:215-21. ([Abstract](#))
- Schüler A, Manns MP. Treatment of autoimmune hepatitis. In: Arroyo V, Bosch J, Rodés J (eds) *Treatment in Hepatology*. Masson, S.A., Paris, p 375-83. 1995.
- Serfaty L, De Lussse A, Rosmorduc O, et al. Ursodeoxycholic acid therapy and the risk of colorectal adenoma in patients with primary biliary cirrhosis: an observational study. *Hepatology* 2003;38:203-9. ([Abstract](#))
- Soloway RD, Summerskill WH, Baggenstoss AH, et al. Clinical, biochemical, and histological remission of severe chronic active liver disease: a controlled study of treatments and early prognosis. *Gastroenterology* 1972;63:820-33. ([Abstract](#))
- Stechemesser E, Klein R, Berg PA. Characterization and clinical relevance of liver-pancreas antibodies in autoimmune hepatitis. *Hepatology* 1993;18:1-9. ([Abstract](#))
- Sternsdorf T, Guldner HH, Szostecki C, et al. Two nuclear dot-associated proteins, PML and Sp100, are often coautoimmunogenic in patients with primary biliary cirrhosis. *Scand J Immunol* 1995;42:257-68. ([Abstract](#))
- Strassburg CP, Alex B, Zindy F, et al. Identification of cyclin A as a molecular target of antinuclear antibodies (ANA) in hepatic and non-hepatic autoimmune diseases. *J Hepatol* 1996;25:859-66. ([Abstract](#))
- Strassburg CP, Jaeckel E, Manns MP. Anti-mitochondrial antibodies and other immunological tests in primary biliary cirrhosis. *Eur J Gastroenterol Hepatol* 1999;11:595-601. ([Abstract](#))
- Strassburg CP, Manns MP. Autoantibodies and autoantigens in autoimmune hepatitis. *Semin Liver Dis* 2002;22:339-352. ([Abstract](#))
- Strassburg CP, Manns MP. Autoimmune hepatitis versus viral hepatitis C. *Liver* 1995;15:225-32. ([Abstract](#))
- Strassburg CP, Manns MP. Autoimmune tests in primary biliary cirrhosis. *Baillieres Best Pract Res Clin Gastroenterol* 2000;14:585-99. ([Abstract](#))
- Strassburg CP, Manns MP. Primär biliäre Zirrhose und primär sklerosierende Cholangitis. *Internistische Praxis* 1996;36:57-74.
- Strassburg CP, Manns MP. Primary biliary liver cirrhosis and overlap syndrome. *Diagnosis and therapy. Internist (Berl)* 2004;45:16-26. ([Abstract](#))
- Strassburg CP, Obermayer-Straub P, Alex B, et al. Autoantibodies against glucuronosyltransferases differ between viral hepatitis and autoimmune hepatitis. *Gastroenterology* 1996;111:1576-86. ([Abstract](#))
- Strassburg CP, Obermayer-Straub P, Manns MP. Autoimmunity in hepatitis C and D virus infection. *J. Viral. Hepat.* 1996;3:49-59. ([Abstract](#))
- Strassburg CP, Obermayer-Straub P, Manns MP. Autoimmunity in liver diseases. *Clin Rev Allergy Immunol* 2000;18:127-39. ([Abstract](#))
- Strettell MD, Thomson LJ, Donaldson PT, et al. HLA-C genes and susceptibility to type 1 autoimmune hepatitis. *Hepatology* 1997;26:1023-6. ([Abstract](#))
- Sudan D, Deroover A, Chinnakotla S, et al. Radiochemotherapy and transplantation allow long-term survival for nonresectable hilar cholangiocarcinoma. *Am J Transplant* 2002;2:774-9. ([Abstract](#))

- Sugimura T, Obermayer-Straub P, Kayser A, et al. A major CYP2D6 autoepitope in autoimmune hepatitis type 2 and chronic hepatitis C is a three-dimensional structure homologous to other cytochrome P450 autoantigens. *Autoimmunity* 2002;35:501-13. (Abstract)
- Szostecki C, Krippner H, Penner E, et al. Autoimmune sera recognize a 100 kD nuclear protein antigen (sp-100). *Clin Exp Immunol* 1987;68:108-16. (Abstract)
- Szostecki C, Will H, Netter HJ, et al. Autoantibodies to the nuclear Sp100 protein in primary biliary cirrhosis and associated diseases: epitope specificity and immunoglobulin class distribution. *Scand J Immunol* 1992;36:555-64. (Abstract)
- Tan EM, Chan EKL, Sullivan KF, et al. Antinuclear antibodies (ANAs): diagnostically specific immune markers and clues toward the understanding of systemic autoimmunity. *Clin Immunol Immunopathol*. 1998;47:121-41. (Abstract)
- Terjung B, Spengler U, Sauerbruch T, et al. "Atypical p-ANCA" in IBD and hepatobiliary disorders react with a 50-kilodalton nuclear envelope protein of neutrophils and myeloid cell lines. *Gastroenterology* 2000;119:310-22. (Abstract)
- Tillmann HJ, Jackel E, Manns MP. Liver transplantation in autoimmune liver disease--selection of patients. *Hepatogastroenterology* 1999;46:3053-9. (Abstract)
- Tischendorf JJ, Hecker H, Kruger M, et al. Characterization, outcome, and prognosis in 273 patients with primary sclerosing cholangitis: A single center study. *Am J Gastroenterol* 2007;102:107-14. (Abstract)
- Tischendorf JJ, Meier PN, Strassburg CP, et al. Characterization and clinical course of hepatobiliary carcinoma in patients with primary sclerosing cholangitis. *Scand J Gastroenterol* 2006;41:1227-34. (Abstract)
- Treichel U, Poralla T, Hess G, et al. Autoantibodies to human asialoglycoprotein receptor in autoimmune-type chronic hepatitis. *Hepatology* 1990;11:606-12. (Abstract)
- Tsuji K, Watanabe Y, Van De Water J, et al. Familial primary biliary cirrhosis in Hiroshima. *J Autoimmun* 1999;13:171-8. (Abstract)
- Tukey RH, Strassburg CP. Genetic multiplicity of the human UDP-glucuronosyltransferases and regulation in the gastrointestinal tract. *Mol Pharmacol* 2001;59:405-14. (Abstract)
- Tung BY, Emond MJ, Haggitt RC, et al. Ursodiol use is associated with lower prevalence of colonic neoplasia in patients with ulcerative colitis and primary sclerosing cholangitis. *Ann Intern Med* 2001;134:89-95. (Abstract)
- Uibo R, Salupere V. The epidemiology of primary biliary cirrhosis: immunological problems. *Hepatogastroenterology* 1999;46:3048-52. (Abstract)
- Van De Water J, Gershwin Me, Leung P, et al. The autoepitope of the 74-kD mitochondrial autoantigen of primary biliary cirrhosis corresponds to the functional site of dihydrolipoamide acetyltransferase. *J Exp Med* 1988;167:1791-9. (Abstract)
- Van De Water J, Shimoda S, Niho Y, et al. The role of T cells in primary biliary cirrhosis. *Semin Liver Dis* 1997;17:105-13. (Abstract)
- Van Hoogstraten HJ, Vleggaar FP, Boland GJ, et al. Budesonide or prednisone in combination with ursodeoxycholic acid in primary sclerosing cholangitis: a randomized double-blind pilot study. Belgian-Dutch PSC Study Group [see comments]. *Am J Gastroenterol* 2000;95:2015-22. (Abstract)
- Van Norstrand MD, Malinchoc M, Lindor KD, et al. Quantitative measurement of autoantibodies to recombinant mitochondrial antigens in patients with primary biliary cirrhosis: relationship of levels of autoantibodies to disease progression. *Hepatology* 1997;25:6-11. (Abstract)
- Van Steenberghe W, Scirot R, Van Eyken P, et al. Combined treatment with methotrexate and ursodeoxycholic acid in non-cirrhotic primary biliary cirrhosis. *Acta Clin Belg* 1996;51:8-18. (Abstract)
- Van Thiel DH, Wright H, Carroll P, et al. Tacrolimus: A potential new treatment for autoimmune chronic active hepatitis: results of an open-label preliminary trial. *Am J Gastroenterol*. 1995;90:771-6. (Abstract)
- Vento S, Cainelli F, Ferraro T, et al. Autoimmune hepatitis type 1 after measles. *Am J Gastroenterol*. 1996;91:2618-20. (Abstract)
- Vento S, Cainelli F, Renzini C, et al. Autoimmune hepatitis type 2 induced by HCV and persisting after viral clearance. *Lancet* 1997;350:1298-9. (Abstract)
- Vento S, Garofano T, Di Perri G, et al. Identification of hepatitis A virus as a trigger for autoimmune chronic hepatitis type 1 in susceptible individuals. *Lancet* 1991;337:1183-7. (Abstract)

## 508 Hepatology 2012

- Vento S, Guella L, Mirandola F, et al. Epstein-Barr virus as a trigger for autoimmune hepatitis in susceptible individuals. *Lancet* 1995;346:608-9. ([Abstract](#))
- Vogel A, Heinrich E, Bahr MJ, et al. Long-term outcome of liver transplantation for autoimmune hepatitis. *Clin Transplant* 2004;18:62-69. ([Abstract](#))
- Vogel A, Liermann H, Harms A, et al. Autoimmune regulator AIRE: Evidence for genetic differences between autoimmune hepatitis and hepatitis as part of the autoimmune polyglandular syndrome type 1. *Hepatology* 2001;33:1047-52. ([Abstract](#))
- Vogel A, Manns MP, Strassburg CP. Autoimmunity and viruses. *Clin Liver Dis* 2002;6:451-5 ([Abstract](#))
- Vogel A, Strassburg CP, Manns MP. 77 C/G Mutation in the Tyrosine Phosphatase CD45 and Autoimmune Hepatitis: Evidence for a Genetic Link. *Genes and Immunity* 2003;4:79-81. ([Abstract](#))
- Vogel A, Strassburg CP, Manns MP. Genetic association of vitamin D receptor polymorphisms with primary biliary cirrhosis and autoimmune hepatitis. *Hepatology* 2002;35:126-31. ([Abstract](#))
- Volkman M, Martin L, Baurle A, et al. Soluble liver antigen: isolation of a 35-kd recombinant protein (SLA-p35) specifically recognizing sera from patients with autoimmune hepatitis. *Hepatology* 2001;33:591-6. ([Abstract](#))
- Waldenström J. Leber, Blutproteine und Nahrungseiweisse. *Dtsch Gesellsch Verd Stoffw* 1950; 15:113-9. ([Abstract](#))
- Warnes TW, Smith A, Lee FI, et al. A controlled trial of colchicine in primary biliary cirrhosis. Trial design and preliminary report. *J Hepatol* 1987;5:1-7. ([Abstract](#))
- Weismüller TJ, Wedemeyer J, Kubicka S, et al. The challenges in primary sclerosing cholangitis - Aetiopathogenesis, autoimmunity, management and malignancy. *J Hepatol* 2008;48:S38-S57. ([Abstract](#))
- Wesierska-Gadek J, Hohenauer H, Hitchman E, et al. Autoantibodies against nucleoporin p62 constitute a novel marker of primary biliary cirrhosis. *Gastroenterology* 1996;110:840-7. ([Abstract](#))
- Wies I, Brunner S, Henninger J, et al. Identification of target antigen for SLA/LP autoantibodies in autoimmune hepatitis [see comments]. *Lancet* 2000;355:1510-5. ([Abstract](#))
- Wiesner RH, Grambsch PM, Dickson ER, et al. Primary sclerosing cholangitis: natural history, prognostic factors and survival analysis. *Hepatology* 1989;10:430-6. ([Abstract](#))
- Wiesner RH, Ludwig J, Lindor KD, et al. A controlled trial of cyclosporine in the treatment of primary biliary cirrhosis. *N Engl J Med* 1990;322:1419-24. ([Abstract](#))
- Wiesner RH, Porayko MK, Dickson ER, et al. Selection and timing of liver transplantation in primary biliary cirrhosis and primary sclerosing cholangitis. *Hepatology* 1992;16:1290-9. ([Abstract](#))
- Wolfhagen FHJ, Van Hoogstraaten HJF, Van Buuren HR. Triple therapy with ursodeoxycholic acid, prednisone, and azathioprine in primary biliary cirrhosis: a 1 year randomized, placebo controlled study. *J Hepatol* 1998;29:736-42. ([Abstract](#))
- Worman HJ. Primary biliary cirrhosis and the molecular cell biology of the nuclear envelope. *Mt Sinai J Med* 1994;61:461-75. ([Abstract](#))
- Wright HI, Bou-Abboud CF, Hassanenstein T, et al. Disease recurrence and rejection following liver transplantation for autoimmune chronic active liver disease. *Transplantation* 1992;53:136-9. ([Abstract](#))
- Zanger UM, Hauri HP, Loeper J, et al. Antibodies against human cytochrome P-450db1 in autoimmune hepatitis type 2. *Proc. Natl. Acad. Sci. USA* 1988;85:8256-60. ([Abstract](#))
- Zuchner D, Sternsdorf T, Szosteck C, et al. Prevalence, kinetics, and therapeutic modulation of autoantibodies against Sp100 and promyelocytic leukemia protein in a large cohort of patients with primary biliary cirrhosis. *Hepatology* 1997;26:1123-30. ([Abstract](#))

## 29. Vascular Liver Disease

*Matthias J. Bahr*

*“It is impossible to explain or to understand the morbid appearances of the liver, without referring to its intimate structure, and as some points relating to this have been only lately made out, I shall commence with a short account of it.”*

*Georg Budd, Diseases of the Liver, 1853*

Vascular liver diseases comprise a heterogeneous group of mostly rare hepatic disorders – some of them exceedingly rare. This is why most of the evidence regarding diagnosis and management results from retrospective and prospective cohort studies rather than from randomized controlled trials.

Every single part of the hepatic vasculature may be affected, i.e., hepatic sinusoids, portal vein, hepatic artery and liver veins. The clinical presentation varies widely depending on the type of disease but also within the individual disease entities. Vascular liver diseases may present as acute disorders or chronic liver disease, as hepatocellular necrosis or cholestasis, as tumour-like lesions or portal hypertension.

The spectrum of underlying causes is wide, and in many cases multiple risk factors will result in the development of clinically significant disease (Table 1).

### **Disorders of the hepatic sinusoid**

Hepatic sinusoidal disease may present as luminal obstruction (i.e., sinusoidal obstruction syndrome), as luminal enlargement (i.e., peliosis hepatis) or as perisinusoidal fibrosis. Whether the latter should be regarded as a separate disease entity is debatable, as perisinusoidal fibrosis may also be observed as a histological feature of common diseases such as steatohepatitis. Both sinusoidal obstruction syndrome as well as peliosis hepatis are not strictly confined to the hepatic sinusoids but may extend to the hepatic venous system.

### **Sinusoidal obstruction syndrome**

Sinusoidal obstruction syndrome (SOS), previously referred to as hepatic venoocclusive disease (VOD), is a circulatory disorder primarily affecting the hepatic sinusoids. Involvement of the hepatic central veins may occur, but studies after conditioning for hematopoietic cell transplantation have demonstrated that in more

than 40% of patients with SOS the hepatic venous system is not involved. The proportion of sole sinusoidal affection falls to 25% in patients with severe SOS (DeLeve 2009).

**Table 1. Classification of predisposing factors for vascular liver disease.**

Hereditary disorders	<ul style="list-style-type: none"> <li>• Inherited thrombophilia, e.g., factor V Leiden mutation, mutations of prothrombin, protein C, protein S, antithrombin III</li> <li>• Hereditary hemorrhagic teleangiectasia</li> </ul>
Congenital malformations	<ul style="list-style-type: none"> <li>• Webs, shunts, aneurysms</li> </ul>
Acquired cellular defects	<ul style="list-style-type: none"> <li>• Myeloproliferative disease</li> <li>• Paroxysmal nocturnal hemoglobinuria</li> <li>• Malignancy</li> </ul>
Inflammatory disease & immune mediated disorders	<ul style="list-style-type: none"> <li>• Focal inflammatory lesions causing thrombosis, e.g., pancreatitis, diverticulitis, appendicitis, cholecystitis, abscesses, inflammatory bowel disease</li> <li>• Vasculitis, e.g., polyarteritis nodosa, Behçet syndrome</li> <li>• Rheumatic disease</li> </ul>
Infectious diseases	<ul style="list-style-type: none"> <li>• Schistosomiasis</li> <li>• Bacillary angiomatosis (<i>Bartonella h.</i>)</li> </ul>
Miscellaneous	<ul style="list-style-type: none"> <li>• Drugs, e.g., oral contraceptives, azathioprine, chemotherapy</li> <li>• Pregnancy</li> <li>• Cirrhosis</li> <li>• Radiation</li> </ul>

## Pathophysiology

Although many risk factors may be complicated by sinusoidal obstruction syndrome, the by far most common cause in the Western world are myeloablative regimens in the preparation for hematopoietic stem cell transplantation (HSCTx), particularly when the transplant is for a malignancy. The proportion of patients with SOS after HSCTx varies from the single-digit percentage range up to 50% if highly toxic regimens are chosen. Apart from conditioning regimens for HSCTx (high-dose chemotherapy plus total body irradiation), other drugs have been implicated in the development of SOS (Table 2). Originally, the syndrome was described in conjunction with the ingestion of herbal teas or foods containing pyrrolizidine alkaloids.

Both the histopathological changes and the clinical picture of SOS were experimentally studied in a rat model using monocrotaline, a pyrrolizidine alkaloid that is directly toxic to sinusoidal endothelial cells. These experiments have confirmed the primary sinusoidal damage infrequently followed by central venous involvement (DeLeeve 1996).

## Clinical presentation and diagnosis

The characteristic clinical presentation of patients with SOS is weight gain-associated or not with ascites, hepatomegaly with right upper quadrant pain, and jaundice. The onset of symptoms usually occurs between day 10 and day 20 after cyclophosphamide-containing regimens but can be delayed up to 1 month after conditioning therapy if other therapies are used.

Severity of SOS varies from mild forms that just meet the diagnostic criteria to rapidly progressing and eventually life-threatening disease (McDonald 1993). In

patients not requiring treatment of fluid excess or hepatic pain, SOS is considered mild and is associated with a self-limiting course. Treatment associated with a complete remission within 100 days is considered moderate disease. If SOS does not resolve by day 100, it is categorized as severe. This classification, however, is retrospective and does not support clinical decision-making.

**Table 2. Drugs associated with sinusoidal obstruction syndrome**

- 
- 6-mercaptopurine
  - 6-thioguanine
  - Actinomycin D
  - Azathioprine
  - Busulfan\*
  - Cytosine arabinoside
  - Cyclophosphamide\*
  - Dacarbazine
  - Gemtuzumab-ozogamicin
  - Melphalan\*
  - Oxaliplatin
  - Urethane
- 

\* Exclusively reported with conditioning regimens for HSCTx (modified according to DeLeve 2009)

Primarily, SOS is a clinical diagnosis with the following characteristics: (1) hepatotoxic conditioning regimen for HSCTx with an appropriate temporal relation to the development of clinical signs and symptoms, (2) weight gain & hepatic pain & jaundice and, (3) negative work-up for other causes. In patients meeting these criteria, diagnosis can be made with reasonable certainty and solely based on clinical judgement. Differential diagnoses comprise cholestatic jaundice due to sepsis, drug-induced cholestasis, fluid overload due to renal failure or congestive heart failure, liver involvement by viral or fungal infections, and acute graft-versus-host disease. However, in up to 20% of patients the diagnosis of SOS cannot be reliably made on clinical grounds (McDonald 1993 & 2004). This has promoted the development of scoring systems such as the Seattle or the Baltimore Criteria (Jones 1987; McDonald 1993) (Table 3). However, up to 50% of patients not meeting the Baltimore criteria may exhibit histological features of SOS (Shulman 1994).

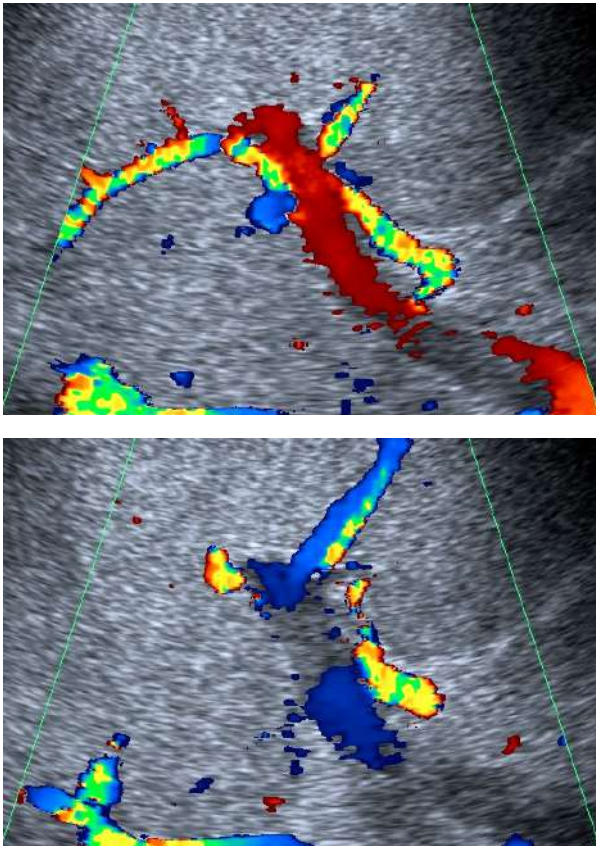
**Table 3. Clinical diagnosis of sinusoidal obstruction syndrome after HSCTx.**

<b>Seattle criteria</b> (McDonald 1993)	<b>Baltimore criteria</b> (Jones 1987)
At least two of the following findings within 20 days of transplantation:*	Hyperbilirubinemia >34.2 $\mu\text{mol/L}$ (2 mg/dL) plus $\geq 2$ additional criteria
<ul style="list-style-type: none"> <li>• Bilirubin &gt;34.2 <math>\mu\text{mol/L}</math> (2 mg/dL)</li> <li>• Hepatomegaly or right upper quadrant pain of liver origin</li> <li>• <math>\geq 2\%</math> weight gain due to fluid accumulation</li> </ul>	<ul style="list-style-type: none"> <li>• Usually painful hepatomegaly</li> <li>• <math>\geq 5\%</math> weight gain</li> <li>• Ascites</li> </ul>

\* The 20-days rule applies to cyclophosphamide containing regimens, should be adjusted according to the regimen actually used.

The gold standard to confirm SOS is based on the combination of hepatic histology plus measurement of the wedged hepatic venous pressure gradient (HVPG)

>10 mmHg, specificity >90%, PPV >85%). Both can be achieved during a single procedure via the transvenous route, especially as increased bleeding risk often precludes percutaneous liver biopsy. However, histology may be negative due to the sometimes patchy character of the disease. Imaging techniques are used to confirm hepatomegaly or ascites and will help to rule out differential diagnoses such as biliary obstruction. A more specific sign is the finding of hepatic inflow blockage with reduced or reversed portal flow in colour Doppler ultrasound (Figure 1). In addition, attenuation of hepatic venous flow or gallbladder wall edema may be detected. Some authors suggest the use of composite imaging scores (Lassau 2002).



**Figure 1. Doppler ultrasound in sinusoidal obstruction syndrome.** Exemplary case showing undulating portal venous flow in a jaundiced patient after HSCTx.

### **Management and prognosis**

Taking into account that SOS is probably underdiagnosed solely employing clinical criteria, case fatality rates of detected SOS vary between 15 and 20% (DeLeve 2009). Apart from deep jaundice additional signs of liver failure such as coagulopathy or hepatic encephalopathy may be missing. In contrast, systemic



complications leading to multiple organ failure (renal, pulmonary) are the main reasons for death in these patients. This points to the necessity of a closely supervised management concept. Highly toxic conditioning regimens should possibly be avoided. Though commonly used, currently published data are too scarce to endorse prophylactic therapy (e.g., ursodeoxycholic acid, heparin, liposomal PGE<sub>2</sub>).

Several treatments have been suggested for established SOS, e.g., thrombolysis using tPA or defibrotide. In addition, invasive strategies such as TIPS or liver transplantation were evaluated. However, current knowledge is mainly based on case reports or cohorts. Although current guidelines do not advise for or against specific medical treatments, some recommendations can be made (DeLeve 2009). First of all, fluid management should aim to control fluid overload (using diuretics, paracentesis, hemofiltration/hemodialysis). Thrombolysis has not proved successful and was associated with severe complications like bleeding. Several non-controlled cohort studies suggested positive effects using defibrotide, a mixture of single-stranded oligodeoxyribonucleotides derived from porcine intestinal mucosa. Phase II studies are completed (Richardson 2010) and Phase III studies are under way. This compound can also be used in multiple organ failure without substantially increasing the bleeding risk.

Unlike Budd-Chiari syndrome, decompression of portal hypertension using TIPS does not improve SOS. For patients with favourable prognosis of the underlying hematopoietic disorder after HSCTx, liver transplant might be considered.

## **Peliosis hepatis**

Peliosis hepatis is a rare disorder characterized by single or multiple blood-filled cystic cavities within the hepatic tissue. Prevalence may vary between 0.03% in HIV infection, 0.2% in pulmonary tuberculosis and up to 20% after renal transplantation. There is no favored localisation of the peliotic lesions and appearance at all ages, including a fetal form, has been described. The size ranges from submillimetres to centimetres but rarely exceeds 3 cm. The histopathological appearance may show a missing endothelial cell lining with hepatocytes directly serving as boundary (parenchymal type). In other cases the endothelium may be preserved but the hepatic sinusoids appear dilated. The aneurysmal dilation may extend to the central vein (phlebotatic type) (Yanoff 1964, Tsokos 2005).

## **Pathophysiology**

Several risk factors have been accused to promote the development of peliosis hepatis, e.g., infections, drugs or malignant disorders (Table 4). However, the exact pathogenesis of peliosis hepatis is largely speculative. The histological appearance suggests that endothelial damage leads to the destruction of the endothelial lining. Other hypotheses favour an increased sinusoidal pressure resulting in the widening of the sinusoidal lumen with consecutive destruction of the sinusoidal endothelium or primary hepatocellular necrosis replaced by blood-filled cystic lesions. Fibrotic changes and even liver cirrhosis as well as regenerative nodules may be found, but it is unclear whether these features are directly linked to peliosis hepatis or whether they are just coincidental.

## **Clinical presentation and diagnosis**

In the majority of cases, peliosis hepatis is asymptomatic and incidentally detected during hepatic imaging. On rare occasions, the peliotic cysts may rupture leading to

intrahepatic or intraabdominal hemorrhage. Individual cases with overt liver disease were reported, characterised by hepatomegaly, jaundice, ascites, portal hypertension and liver failure. Extrahepatic manifestations may be found in organs of the mononuclear phagocytic system (e.g., spleen, lymph nodes, bone marrow) but also in lungs, kidneys, parathyroid or adrenal glands, or other parts of the gastrointestinal tract.

Usually, peliosis hepatis is easily detected by imaging techniques. However, discrimination between peliosis and other benign or malignant lesions may turn difficult. Peliotic lesions miss a mass effect on the adjacent hepatic vasculature. Blood flow within the lesion is slow, resulting in a hypodense appearance after contrast application in CT. However, in some patients a ring-like accumulation of contrast media may be present. Using MRI, low intensity is seen in T1-weighted images while T2-weighted images show a high signal. Though imaging techniques may assist the diagnosis of peliosis hepatis, a liver biopsy is often needed for final confirmation. Wedged hepatic venography may also be diagnostic, but its use needs a strong suspicion.

**Table 4. Risk factors reported with peliosis hepatis.**

Infections	<ul style="list-style-type: none"> <li>• Human immunodeficiency virus</li> <li>• <i>Bartonella</i> spp. (bacillary angiomatosis)</li> <li>• Tuberculosis</li> </ul>
Drugs, toxins	<ul style="list-style-type: none"> <li>• Azathioprine, cyclosporine</li> <li>• Anabolic steroids, glucocorticoids, oral contraceptives, tamoxifen</li> <li>• Vinyl chloride, arsenic, thorium oxide</li> </ul>
Malignant and benign tumours	<ul style="list-style-type: none"> <li>• Multiple myeloma, Waldenström disease</li> <li>• Hodgkin disease</li> <li>• Hepatocellular adenoma</li> </ul>
Miscellaneous	<ul style="list-style-type: none"> <li>• Renal transplantation</li> <li>• Celiac disease, diabetes mellitus</li> <li>• No underlying disorder in up to 50%</li> </ul>

### Management and prognosis

In most cases, peliosis hepatis will not progress to symptomatic disease. Thus, in these patients management has to concentrate on the identification and, if required, treatment of the underlying disease. Causal treatment is the therapeutic mainstay and leads to regression of the peliotic lesions in the majority of cases. However, in individual cases surgery may be indicated if the risk of cyst rupture and consecutive bleeding is estimated to be high. If liver failure and portal hypertension dominate the clinical picture liver transplantation might be considered provided etiology does not pose a contraindication.

### Disorders of the hepatic artery

Pathologies involving the hepatic artery may lead to different clinical pictures (Table 5, Figure 2).

Occlusion of the arterial lumen results in ischemia of the supplied tissue. Though gross hepatocellular necrosis may follow, such as in ischemic hepatitis, preserved portal venous oxygen supply often prevents the most devastating damage. In

contrast to the hepatic parenchyma, the biliary system is exclusively supplied arterially and, therefore, more susceptible to ischemic damage. Clinically, this may present as an elevation of cholestasis-associated liver enzymes (e.g., gamma GT, alkaline phosphatase). In more severe cases, structural damage to bile ducts may be irreversible (i.e., ischemic cholangiopathy). Especially after orthotopic liver transplantation ischemia type biliary lesions (ITBL) still pose a major challenge for clinical management.

**Table 5. Etiology of hepatic artery disease.**

Obstruction or destruction of the hepatic artery	<ul style="list-style-type: none"> <li>• Hepatic artery embolism or thrombosis</li> <li>• Vasculitis</li> <li>• Sickle cell anemia</li> <li>• Hemolytic uremic syndrome</li> <li>• Chronic transplant rejection</li> </ul>
Aneurysms	<ul style="list-style-type: none"> <li>• Congenital malformations</li> <li>• <i>Polyarteritis nodosa</i> (PAN)</li> <li>• Focal inflammation, trauma</li> </ul>
Shunts	<ul style="list-style-type: none"> <li>• Congenital malformations</li> <li>• Hereditary hemorrhagic teleangiectasia</li> </ul>



**Figure 2. Spontaneous arterioportal shunt.** Angiography in a patient with non-cirrhotic portal hypertension. A small arterioportal shunt is detected by superselective catheterisation.

Apart from sequelae due to hepatic ischemia, hepatic artery disease may present either as an aneurysm or as a shunt. Aneurysms of the hepatic artery are often detected incidentally on imaging procedures. The majority are asymptomatic but abdominal pain or – in rare cases – obstructive jaundice may develop. In a minority of patients (about 20%) multiple aneurysms are present. Males are more often

affected than women. The risk of rupture and subsequent hemorrhage is high and may reach up to 80% – depending on the size of the aneurysm. Therefore, either radiological intervention or surgery needs to be evaluated (Hulsberg 2011, Christie 2011).

In contrast to aneurysms, shunts involving the hepatic artery are predominantly symptomatic. The spectrum of symptoms is wide including abdominal pain, portal hypertension or signs of high-output heart failure. The therapeutic approach has to be individualized including radiological interventions or surgical procedures.

## **Hereditary hemorrhagic teleangiectasia (Osler-Weber-Rendu syndrome)**

Hereditary hemorrhagic teleangiectasia (HHT) is a highly penetrant, autosomal dominant disease showing a heterozygous prevalence between 1:5000 and 1:8000. It is characterized by progressive and multivisceral development of arteriovenous malformations (Govani 2009).

Mutations in several genes interacting with transforming growth factor (TGF)- $\beta$  receptor have been identified in HHT. According to the genes involved, different subtypes can be discriminated:

- HHT 1 (ENG coding for endoglin, chromosome 9q33-q34.1),
- HHT 2 (*ACVRL1* coding for activin A receptor type II-like kinase ALK-1, chromosome 12q11-q14),
- HHT 3 (gene not yet identified, chromosome 5q31.3-q32),
- HHT 4 (gene not yet identified, chromosome 7p14),
- Juvenile polyposis/HHT (*SMAD4*, chromosome 18q21.1).

Liver involvement may be found in all subtypes but appears to be more frequent in HHT 2. Though hereditary, HHT is characterized by marked intrafamilial variation.

### **Clinical presentation and diagnosis**

HHT is a multivisceral disease. Apart from the nasopharynx and the gastrointestinal tract, central nervous (~10%), pulmonary (~50%) and hepatic involvement occur at high frequency. Accordingly, the spectrum of clinical disease is wide, e.g., anemia, seizures, subarachnoid hemorrhage, paraplegia, transient ischemic attacks/stroke, dyspnea, cyanosis, polycythemia, abdominal pain and hepatic abscesses. Symptoms develop progressively throughout life. Telangiectasias appear before the age of 20 in half, before 40 in two-thirds of the patients. Thereafter it takes one or two decades for the development of significant bleeding or symptomatic visceral involvement (Plauchu 1989, Govani 2009).

The proportion of hepatic involvement in HHT is reported between 30 and 75%. With the improvement of imaging technology over time, the reported incidence of hepatic malformations increased. The clinical picture of liver involvement in HHT depends on the predominant type of malformation (i.e., arterioportal vs. arteriovenous shunts). Arteriovenous malformations increase cardiac output. In individual cases up to 20 L/min may be reached. These patients suffer from high output cardiac failure. In addition, symptoms of a mesenteric steal syndrome (e.g., postprandial abdominal pain) and signs of biliary ischemia (e.g., biliary abscesses) may occur. As a consequence of ischemia, nodular regeneration of the liver

develops (HHT-associated pseudocirrhosis). Arterioportal malformations will cause portal hypertension with all its complications (Buscarini 2006, Garcia-Tsao 2000).

Diagnosis of HHT is made using the Curaçao criteria, 3 of 4 of which need to be fulfilled (Shovlin 2000, Faughnan 2011):

- recurrent spontaneous epistaxis,
- telangiectasias, multiple and in typical localisation,
- positive family history,
- visceral arteriovenous malformations (lung, liver, brain, spine).

Every patient with HHT should be screened for hepatic vascular malformations. Using Doppler ultrasound, screening is performed with high sensitivity and specificity (Table 6) (Caselitz 2003). If hepatic involvement is confirmed, cardiac output should be estimated (e.g., via echocardiography). Furthermore, patients must be screened at regular intervals to detect complications such as development of portal hypertension or biliary lesions.

**Table 6. Ultrasound criteria for hepatic involvement in HHT\*.**

Major criteria	<ul style="list-style-type: none"> <li>• Dilated common hepatic artery &gt;7 mm (inner diameter)</li> <li>• Intrahepatic arterial hypervascularization</li> </ul>
Minor criteria	<ul style="list-style-type: none"> <li>• Vmax of the proper hepatic artery &gt;110 cm/s</li> <li>• RI of the proper hepatic artery &lt;0.60</li> <li>• Vmax of the portal vein &gt;25 cm/s</li> <li>• Tortuous course of the extrahepatic hepatic artery</li> </ul>
Facultative findings	<ul style="list-style-type: none"> <li>• Dilated portal vein &gt;13 mm</li> <li>• Dilated liver veins &gt;11 mm</li> <li>• Hepatomegaly &gt;15 cm in midclavicular line</li> <li>• Nodular liver margin</li> </ul>

\* Two major criteria: definitive hepatic involvement in HHT, one major criterium plus minor criteria: probable hepatic involvement (modified according to Caselitz 2003)

### Management of hepatic involvement in HHT

Currently, no established medical therapy for HHT exists. In chronic GI bleeding the use of hormonal therapy (estrogen-progesterone preparations, danacrine), anti-fibrinolytics (aminocaproic acid, tranexamic acid) and other experimental drugs (tamoxifen, interferon, thalidomide, sirolimus) were suggested (Faughnan 2011). However, no data supports the use of these drugs to treat hepatic vascular malformations.

Limited data exist for the use of hepatic artery embolisation and liver transplantation (Buscarini 2006, Chavan 2004). Due to the invasiveness and complication rates of these approaches only patients with moderate to severe symptoms should be regarded as candidates for therapeutic interventions. Hepatic artery embolisation can be used to reduce shunt flow in patients with arteriovenous hepatic shunts. Thus, a significant reduction of cardiac output with improvement of associated symptoms can be achieved. However, complications such as hepatic and biliary necrosis or acute cholecystitis have been described. Success of hepatic artery embolisation very much depends on adequate patient selection. Current guidelines do not endorse general use of embolisation outside of experienced centres but do favour liver transplantation in advanced hepatic involvement of HHT.

## Disorders of the portal vein

In contrast to other disease entities affecting the hepatic vasculature, portal vein thrombosis is a common disease. While portal vein thrombosis is located within the main portal vein and its larger branches, rare forms of portal vein disease affecting the medium-sized and preterminal portal venous branches have been identified. The nomenclature for these diseases is inconsistent (e.g., obliterative portal venopathy, hepatoportal sclerosis, idiopathic portal hypertension, nodular regenerative hyperplasia).

### Portal vein thrombosis

Portal vein thrombosis (PVT) is of heterogeneous aetiology. It is promoted by both local and general risk factors (Tables 7 & 8). In about 20 to 30% of patients a local risk factor can be identified. General risk factors are found in 50-70% (DeLeve 2009, Plessier 2010).

**Table 7. Local risk factors for portal vein thrombosis.**

Malignancy	<ul style="list-style-type: none"> <li>• Primary hepatic or abdominal cancer</li> <li>• Metastatic disease</li> </ul>
Focal inflammation	<ul style="list-style-type: none"> <li>• Neonatal omphalitis, umbilical vein catheterisation</li> <li>• Pancreatitis, duodenal ulcer, cholecystitis</li> <li>• Diverticulitis, appendicitis, inflammatory bowel disease</li> <li>• Tuberculosis, CMV hepatitis</li> </ul>
Portal venous injury	<ul style="list-style-type: none"> <li>• Cholecystectomy, splenectomy, colectomy, gastrectomy</li> <li>• Surgical portosystemic shunting, TIPS</li> <li>• Liver transplantation, hepatobiliary surgery</li> <li>• Abdominal trauma</li> </ul>
Cirrhosis	<ul style="list-style-type: none"> <li>• Impaired hepatic inflow</li> </ul>

### Clinical presentation and diagnosis

Portal vein thrombosis may present as acute or chronic disease, representing successive stages of the same disease. Special variants of PVT are malignant thrombi resulting from tumours invading the portal venous circulation, septic thrombi also known as acute pylephlebitis, and thrombi resulting from slowed portal venous flow in liver cirrhosis (DeLeve 2009, Plessier 2010).

The typical clinical presentation of acute PVT includes abdominal or lumbar pain of sudden onset or progressing over a few days. Depending on the extent of the thrombosis the pain may be severe and colicky. The diminished mesenteric outflow leads to intestinal congestion. Ileus may develop but without features of intestinal obstruction. Moderate distension of the abdomen is common. However, peritoneal signs are usually absent unless intestinal infarction develops. Fever and a marked systemic inflammatory response may develop even without systemic infection. This is accompanied by elevated laboratory markers of inflammation. In contrast, liver function – apart from intermittent elevation of aminotransferases – is usually not substantially affected by acute PVT unless significant liver damage pre-exists. Clinical features should improve within 5-7 days. Otherwise transmural intestinal ischemia has to be suspected.

Pylephlebitis is characterized by high, spiking fever with chills, a painful liver, and sometimes shock. Blood cultures should be taken (usually *Bacteroides* spp. ± other enteric species). Infected thrombi give rise to the development of hepatic microabscesses (Kanellopoulou 2010).

Cases in whom acute portal vein thrombosis does not resolve, progress to chronic portal vein thrombosis. The obstructed portal vein is replaced by collateral veins bridging the thrombotic part, known as portal cavernoma. There is wide variation in the clinical picture of portal cavernoma. It may rarely lead to obstruction of the extrahepatic bile ducts – so-called portal biliopathy which may be associated with marked jaundice. However, the leading symptom of chronic PVT are the facets of portal hypertension (e.g., portosystemic collaterals such as gastric or esophageal varices). As liver function is usually not impaired, complications such as hepatic encephalopathy or ascites are substantially less frequent than in liver cirrhosis. Hepatopulmonary syndrome may be found in up to 10% of patients.

PVT is a common complication of liver cirrhosis with an increasing prevalence in more severe disease stages. It needs to be discriminated from portal venous obstruction caused by hepatocellular carcinoma. Pathophysiologically, PVT in cirrhosis arises as a consequence of the reduction in hepatic inflow leading to flow reduction and eventually stasis within the portal vein. Therefore, thrombi are often partial and development of portal cavernoma is rather unusual. In patients with cirrhosis, a newly developed ascites or significant worsening of existing ascites should trigger the search for PVT.

Both acute PVT and portal cavernoma are easily detected using sonography, CT or MR imaging. Acute PVT presents as intraluminal hyperechoic material in ultrasound, while Doppler imaging demonstrates a lack of blood flow (Figure 3). Using contrast-enhanced ultrasound (CEUS), vascularisation of the thrombus may be used to identify malignant thrombi. As PVT may extend to the mesenteric or splenic veins, thorough assessment of the splanchnic tributaries is mandatory. For detailed assessment of thrombus extension, CT or MR angiography are more sensitive than Doppler sonography. Portal cavernoma presents as serpiginous vessel structures, while the main portal vein or its branches are not visible. As a compensatory mechanism hepatic arteries are usually enlarged. Depending on the individual location and appearance of portal cavernoma it may be mistaken as part of the surrounding organs or as tumour.

### **Management and prognosis**

In acute PVT, recanalisation of the obstructed veins should be aspired. Causal factors require correction where possible. If pylephlebitis is suspected antibiotic therapy should be commenced immediately.

Spontaneous recanalisation without anticoagulation occurs infrequently (<20%). Therefore, anticoagulation is the most commonly used therapeutic strategy to reopen the obstructed portal vein. Though no controlled studies exist, prospective data suggest this approach to be successful in about 40% of patients. The success rate increases to about 60% if neither the splenic vein is involved nor ascites is detectable. Anticoagulation should be initiated as early as possible - delay might be associated with treatment failure. Major complications are reported in less than 5% of treated patients. (DeLeve 2009, Plessier 2010, Hall 2011).

Experience with other treatment modalities is limited (e.g., systemic/local thrombolysis, surgical thrombectomy, transjugular intrahepatic portosystemic stent

[TIPS]). Systemic thrombolysis appears largely ineffective. Although performed successfully in some centres, major procedure-related complications and even death have been reported for local thrombolysis, which has to be regarded as experimental. Emergency surgical intervention is indicated in suspected intestinal infarction. In these cases, surgical thrombectomy can be performed.

(A)



(B)



**Figure 3. Acute portal vein thrombosis.** Ultrasound of patient with acute PVT. (A) Hyperechoic material is located within the main portal vein. (B) Using the power mode for flow detection, blood flow is limited to those parts of the portal vein without hyperechoic material.

The therapeutic approach is different in patients with PVT associated with liver cirrhosis. Interventional therapy using TIPS appears to be highly effective (Luca



2011). Preliminary data even support the use of systemic thrombolysis in these patients (De Santis 2010).

If treatment is initiated early in acute PVT the outcome is favourable. Symptoms may sometimes disappear within hours after start of therapy and portal hypertension rarely develops. Overall mortality is well below 10% (DeLeve 2009, Plessier 2010).

In patients with portal cavernoma prevention of gastrointestinal bleeding due to portal hypertension is a main focus of therapy. The use of non-selective beta-blockers is incompletely evaluated in portal cavernoma. However, an approach similar to portal hypertension in liver cirrhosis is supported by current guidelines and appears to improve prognosis (DeLeve 2009). Due to the variable genesis of PVT, individual assessment for risk of recurrence of thrombosis and risk of bleeding should be performed. Although data is scarce, anticoagulation seems to be favourable for most patients.

### **Nodular regenerative hyperplasia**

Occlusion of the medium-sized and preterminal portal venous branches induces hypertrophy of the supplied tissue. As a compensatory reaction, regeneration of appropriately perfused tissue gives rise to the development of regenerative nodules. This combination of hypotrophic and hypertrophic liver tissue without signs of fibrosis is the equivalent of nodular regenerative hyperplasia (Wanless 1990).

Nodular regenerative hyperplasia causes 14-27% of cases with non-cirrhotic portal hypertension (Naber 1991, Nakanuma 1996). In autopsy studies the prevalence is 3.1/100,000, one third of which are associated with portal hypertension (Colina 1989). Nodular regenerative hyperplasia is associated with autoimmune and hematologic disorders, e.g., rheumatoid arthritis, Felty's syndrome, other connective tissue disorders and myeloproliferative disease. It has also been described in infective endocarditis, in conjunction with chemotherapy and after kidney transplantation (Matsumoto 2000).

Clinically, nodular regenerative hyperplasia presents with complications of portal hypertension. Liver function is usually not significantly impaired although individual cases with liver failure have been described (Naber 1990, Blendis 1978, Dumortier 2001). The prognosis depends on the underlying disorder and on the control of portal hypertension.

### **Hepatoportal sclerosis**

Similar to nodular regenerative hyperplasia, hepatoportal sclerosis affects the smaller portal venous branches. In contrast to the former, portal veins are not just destroyed but replaced by filiform fibrotic strands penetrating the hepatic tissue. These fibrotic strands are strictly confined to the portal tracts and do not form fibrotic septae (Nakanuma 2001). Several synonyms are used for hepatoportal sclerosis, e.g., obliterative portal venopathy or idiopathic portal hypertension. However, nomenclature is not well-defined and sometimes overlaps with nodular regenerative hyperplasia.

Hepatoportal sclerosis is rarely found in the Western world but is more common in Asia (e.g., India, Japan). Several risk factors are in discussion: (a) chronic infections, (b) exposure to medication / toxins (e.g., arsenic, vinyl chloride, azathioprine), (c) thrombophilia, (d) immune disease and (e) hereditary factors. Infections and toxins appear to be more common in Asia, while Western patients

suffer more often from thrombophilia (Schouten 2011). Also, HIV infection is regarded as a risk factor for hepatoportal sclerosis.

Liver function as well as liver enzymes are usually unaffected by hepatoportal sclerosis. Complications of portal hypertension pose the main clinical challenge. Typically, the long-term clinical course of the disease is rather stable. Similarly to nodular regenerative hyperplasia, prognosis depends on the underlying disorder and on the control of portal hypertension (Schouten 2011).

## Disorders of the hepatic veins

Budd-Chiari syndrome is the only defined entity of hepatic venous disease. However, other disorders such as the sinusoidal obstruction syndrome or peliosis hepatis may also affect the hepatic venous system. Furthermore, hepatic congestion due to cardiac or pericardial disease shares clinical similarities with Budd-Chiari syndrome.

### Budd-Chiari syndrome

Budd-Chiari syndrome (BCS) is defined as hepatic venous outflow obstruction at any level from the small hepatic veins to the junction of the inferior vena cava (IVC) and the right atrium, regardless of the cause of obstruction (Janssen 2003). Excluded from this definition are obstructions caused by sinusoidal obstruction syndrome and cardiac or pericardial disorders.

#### Pathophysiology

Obstruction of the hepatic outflow may arise from endoluminal lesions, e.g., thrombosis, webs, endophlebitis (primary BCS) or from outside the venous system by luminal invasion or by extrinsic compression, e.g., tumour, abscess, cysts (secondary BCS) (Janssen 2003).

On rare occasions, BCS originates from congenital malformations, e.g., webs or stenotic vessels (Ciesek 2010, Darwish Murad 2009). However, outflow obstruction is usually caused by thrombosis. Prevalence of thrombophilic risk factors are given in Table 8. Thrombi are exclusively located within the hepatic veins in 49% of patients, exclusively within IVC in 2%, and as combined thrombosis of hepatic veins and IVC in 49%. In about 18% a concomitant portal vein thrombosis is identified (Darwish Murad 2009).

Obstruction of hepatic outflow leads to congestion of the drained tissue. Over time this will induce hypertrophy of affected and consecutive regeneration of non-affected parts of the liver. A typical area of hypertrophy is liver segment I (caudate lobe), because it possesses its own separate venous drainage into the IVC. Regenerative nodules may occasionally progress to hepatocellular carcinoma. In addition, intrahepatic collaterals may develop.

#### Clinical presentation and diagnosis

Depending on the location of outflow obstruction, the number of vessels involved and the temporal dynamics of BCS, the clinical presentation varies between light symptoms, even sometimes subclinical disease and dramatic acute complaints which may progress to acute liver failure. The disease might present with a progressively relapsing course successively involving different hepatic veins.

Symptoms of hepatic congestion are ascites (>80% of patients), abdominal pain (>60%) and esophageal varices (>50%). Disturbance of liver function is rather rare,

e.g., hepatic encephalopathy (<10%), as is involvement of extrahepatic organs, e.g., hepatorenal syndrome (<10%) (Darwish Murad 2009).

In the majority of cases, diagnosis of BCS can be obtained using Doppler ultrasound. If technical difficulties obviate diagnosis by ultrasound, MRI is the imaging method of choice. Only in rare cases, liver biopsy or hepatic venography are required to confirm the diagnosis (Janssen 2003). Ultrasound characteristics of BCS are clearly defined (Boozari 2008). They comprise specific signs such as direct visualisation of thrombi, stenoses, webs, replacement of hepatic veins by fibrotic strands or reversed flow in hepatic veins or IVC. Suggestive signs are hepatic collaterals that may be interposed between hepatic veins or may be located on the hepatic capsula. Widening of the caudate vein (>3 mm) is also regarded as suggestive for BCS. These signs serve in the diagnosis of BCS and may be accompanied by a myriad of non-specific changes (e.g., ascites, regenerative nodules, splenomegaly).

**Table 8. Prevalence of thrombophilic risk factors in acute and chronic portal vein thrombosis and in primary Budd-Chiari syndrome\*.**

Risk factor	Portal vein thrombosis	Budd-Chiari syndrome
Myeloproliferative disorders	21% - 40%	40% - 50%
Atypical	14%	25% - 35%
Classical	17%	10% - 25%
Paroxysmal nocturnal hemoglobinuria	0% - 2%	0% - 19%
Antiphospholipid syndrome	6% - 19%	4% - 25%
Factor V Leiden mutation	3% - 32%	6% - 32%
Factor II (prothrombin) mutation	14% - 40%	3% - 7%
Protein C deficiency	0% - 26%	4% - 30%
Protein S deficiency	2% - 30%	3% - 20%
Antithrombin deficiency	0% - 26%	0% - 23%
Plasminogen deficiency	0% - 6%	0% - 4%
Hyperhomocysteinemia	11% - 22%	22% - 37%
TT677 MTHFR genotype	11% - 50%	12% - 22%
Recent pregnancy	6% - 40%	6% - 12%
Recent oral contraceptive use	12% - 44%	6% - 60%
Behçet's disease	0% - 31%	0% - 33%
Connective tissue disease	4%	10%

\* Adult patients without malignancy or cirrhosis (according to DeLeve 2009, Darwish Murad 2009, Plessier 2010).

## Management and prognosis

Treatment strategy in BCS has to be adjusted to the etiology of BCS and the severity of the clinical picture. If BCS is caused by congenital malformations such as webs, radiological interventions using balloon catheter-assisted dilation may be sufficient to solve the problem.

In case of a primary thrombotic event, anticoagulation is the mainstay of therapy (Janssen 2003, DeLeve 2009, Darwish Murad 2009). However, in medium-term follow-up less than one third of patients will be solely treated with anticoagulation

and remain free of further interventions (Darwish Murad 2009). Therefore, interventional techniques (e.g., TIPS, recanalisation) should be evaluated early, especially in patients with moderate to severe symptoms. With the advent of TIPS, the necessity for liver transplantation in BCS has declined sharply. Success rates of TIPS – both in the short-term and in the long-term – are high. Thus, surgical procedures (e.g., surgical shunt, liver transplantation) are only rarely performed. With this approach, actual data show that survival in BCS is above 80% after 2 years (Darwish Murad 2009).

## References

- Blendis LM, Lovell D, Barnes CG, Ritland S, Cattan D, Vesin P. Oesophageal variceal bleeding in Felty's syndrome associated with nodular regenerative hyperplasia. *Ann Rheum Dis* 1978;37:183-6. ([Abstract](#))
- Budd G. On diseases of the liver. Blanchard and Lea. Philadelphia 1853.
- Buscarini E, Plauchu H, Garcia Tsao G, et al. Liver involvement in hereditary hemorrhagic telangiectasia: consensus recommendations. *Liver Int* 2006;26:1040-6. ([Abstract](#))
- Boozari B, Bahr MJ, Kubicka S, Klemphauer J, Manns MP, Gebel M. Ultrasonography in patients with Budd-Chiari syndrome - diagnostic signs and prognostic implications. *J Hepatol* 2008;49:572-80. ([Abstract](#))
- Caselitiz M, Bahr MJ, Bleck JS, et al. Sonographic criteria for the diagnosis of hepatic involvement in hereditary hemorrhagic telangiectasia (HHT). *Hepatology* 2003;37:1139-46. ([Abstract](#))
- Chavan A, Caselitiz M, Gratz KF, et al. Hepatic artery embolization for treatment of patients with hereditary hemorrhagic telangiectasia and symptomatic hepatic vascular malformations. *Eur Radiol* 2004;14:2079-85. ([Abstract](#))
- Christie AB, Christie DB, Nakayama DK, Solis MM. Hepatic artery aneurysms: evolution from open to endovascular repair techniques. *Am Surgeon* 2011;77:608-11. ([Abstract](#))
- Ciesek S, Rifai K, Bahr MJ, et al. Membranous Budd-Chiari syndrome in caucasians. *Scand J Gastroenterol* 2010;45:226-34. ([Abstract](#))
- Colina F, Alberti N, Solis JA, Martinez-Tello FJ. Diffuse nodular regenerative hyperplasia of the liver (DNRH). A clinicopathologic study of 24 cases. *Liver* 1989; 9:253-65. ([Abstract](#))
- Darwish Murad S, Plessier A, Hernandez-Guerra M, et al. Etiology, management, and outcome of the Budd-Chiari syndrome. *Ann Intern Med* 2009;151:167-75. ([Abstract](#))
- DeLeve LD, Valla DC, Garcia-Tsao G. AASLD practice guidelines. Vascular disorders of the liver. *Hepatology* 2009;49:1729-64. ([Abstract](#))
- DeLeve LD, Wang X, Kuhlenkamp JF, Kaplowitz N. Toxicity of azathioprine and monocrotaline in murine sinusoidal endothelial cells and hepatocytes: the role of glutathione and relevance to hepatic venoocclusive disease. *Hepatology* 1996;23:589-99. ([Abstract](#))
- De Santis A, Moscattelli R, Catalano C, et al. Systemic thrombolysis of portal vein thrombosis in cirrhotic patients: a pilot study. *Digest Liver Dis* 2010;42:451-5. ([Abstract](#))
- Dumortier J, Bizollon T, Scoazec JY, et al. Orthotopic liver transplantation for idiopathic portal hypertension: indications and outcome. *Scand J Gastroenterol* 2001;36:417-22. ([Abstract](#))
- Faughnan ME, Palda VA, Garcia-Tsao G, et al. International guidelines for the diagnosis and management of hereditary hemorrhagic telangiectasia. *J Med Genet* 2011;48:73-87. ([Abstract](#))
- Garcia-Tsao G, Korzenik JR, Young L, et al. Liver disease in patients with hereditary hemorrhagic telangiectasia. *N Engl J Med* 2000;343:931-6. ([Abstract](#))
- Govani FS, Shovlin CL. Hereditary haemorrhagic telangiectasia: a clinical and scientific review. *Eur J Hum Genet* 2009;17:860-71. ([Abstract](#))
- Hall TC, Garcea G, Metcalfe M, Bilku D, Dennison AR. Management of acute non-cirrhotic and non-malignant portal vein thrombosis: a systematic review. *World J Surg* 2011;35:2510-20. ([Abstract](#))
- Hulsberg P, de la Garza-Jordan J, Jordan R, Matusz P, Tubbs RS, Loukas M. Hepatic aneurysm: a review. *Am Surg* 2011;77:586-91. ([Abstract](#))
- Janssen HLA, Garcia-Pagan JC, Elias E, et al. Budd-Chiari syndrome: a review by an expert panel. *J Hepatol* 2003;38:364-71. ([Abstract](#))

- Jones RJ, Lee KS, Beschoner WE, et al. Venocclusive disease of the liver following bone marrow transplantation. *Transplantation* 1987;44:778-83. ([Abstract](#))
- Kanellopoulou T, Alexopoulou A, Theodossiades G, Koskinas J, Archimandritis AJ. Pylephlebitis: an overview of non-cirrhotic cases and factors related to outcome. *Scand J Infect Dis* 2010;42:804-11. ([Abstract](#))
- Lassau N, Auperin A, Leclere J, Bennaceur A, Valteau-Couanet D, Hartmann O. Prognostic value of doppler-ultrasonography in hepatic venocclusive disease. *Transplantation* 2002;74:60-6. ([Abstract](#))
- Luca A, Miraglia R, Caruso S, et al. Short- and long-term effects of the transjugular intrahepatic portosystemic shunt on portal vein thrombosis in patients with cirrhosis. *Gut* 2011;60:846-52. ([Abstract](#))
- Matsumoto T, Kobayashi S, Shimizu H, et al. The liver in collagen diseases: pathologic study of 160 cases with particular reference to hepatic arteritis, primary biliary cirrhosis, autoimmune hepatitis and nodular regenerative hyperplasia of the liver. *Liver* 2000;20:366-73. ([Abstract](#))
- McDonald GB, Hinds MS, Fisher LD, et al. Veno-occlusive disease of the liver and multiorgan failure after bone marrow transplantation - a cohort study of 355 patients. *Ann Intern Med* 1993;118:255-67. ([Abstract](#))
- McDonald GB. Liver disease of uncertain cause. *Bone Marrow Transplant* 2004;33:977-8. ([Abstract](#))
- Naber AH, Van Haelst U, Yap SH. Nodular regenerative hyperplasia of the liver: an important cause of portal hypertension in non-cirrhotic patients. *J Hepatol* 1991;12:94-9. ([Abstract](#))
- Nakanuma Y, Hosono M, Sasaki M, et al. Histopathology of the liver in non-cirrhotic portal hypertension of unknown aetiology. *Histopathology* 1996; 28:195-204. ([Abstract](#))
- Nakanuma Y., Tsuneyama K., Ohbu M., Katayanagi K. Pathology and pathogenesis of idiopathic portal hypertension with an emphasis on the liver. *Pathol Res Pract* 2001;197:65-76. ([Abstract](#))
- Plauchu H, de Chadarevian JP, Bideau A, Robert JM. Age-related clinical profile of hereditary hemorrhagic telangiectasia in an epidemiologically recruited population. *Am J Med Genet* 1989;32:291-7. ([Abstract](#))
- Plessier A, Darwish-Murad S, Hernandez-Guerra M, et al. Acute portal vein thrombosis unrelated to cirrhosis: A prospective multicenter follow-up study. *Hepatology* 2010;51:210-8. ([Abstract](#))
- Richardson PG, Soiffer RJ, Antin JH, et al. Defibrotide for the treatment of severe hepatic veno-occlusive disease and multiorgan failure after stem cell transplantation: a multicenter, randomized, dose-finding trial. *Biol Blood Marrow Transplant* 2010;16:1005-17. ([Abstract](#))
- Schouten JNL, Garcia-Pagan JC, Valla DC, Janssen HLA. Idiopathic noncirrhotic portal hypertension. *Hepatology* 2011;54:1071-81. ([Abstract](#))
- Shovlin CL, Guttmacher AE, Buscarini E, et al. Diagnostic criteria for hereditary hemorrhagic telangiectasia (Rendu-Osler-Weber syndrome). *Am J Med Genet* 2000;91:66-7. ([Abstract](#))
- Shulman HM, Fisher LB, Schoch HG, Henne KW, McDonald GB. Venocclusive disease of the liver after marrow transplantation: histological correlates of clinical signs and symptoms. *Hepatology* 1994;19:1171-80. ([Abstract](#))
- Tsokos M, Erbersdopler A. Pathology of peliosis. *Forensic Sci Int* 2005;149:25-33. ([Abstract](#))
- Wanless IR. Micronodular transformation (nodular regenerative hyperplasia) of the liver: a report of 64 cases among 2,500 autopsies and a new classification of benign hepatocellular nodules. *Hepatology* 1990;11:787-97. ([Abstract](#))
- Yanoff M, Rawson AJ. Peliosis hepatis. An anatomic study with demonstration of two varieties. *Arch Pathol* 1964;77:159-65. ([Abstract](#))

## 30. Acute Liver Failure

*Akif Altinbas, Lars P. Bechmann, Hikmet Akkiz, Guido Gerken, Ali Canbay*

### Introduction and definition

Acute liver failure (ALF) is a devastating clinical syndrome, occurring in previously healthy individuals, which is characterized by hepatocellular death and dysfunction (O'Grady 2005). ALF is characterized by onset of coagulopathy (International Normalized Ratio, INR  $\geq 1.5$ ) and hepatic encephalopathy within 26 weeks of symptom appearance in a previously healthy subject (Larson 2010). Exclusion of an underlying liver disease (alcoholic hepatitis, chronic HBV and HCV, autoimmune hepatitis) is mandatory, as management of acute-on-chronic liver failure differs from ALF treatment. The most common causes of ALF in Europe and the US are acetaminophen intoxication, acute hepatitis B (HBV) infection and non-acetaminophen drug-induced liver injury (Bernal 2010). With progressive loss of hepatic function, ALF leads to hepatic encephalopathy, coagulopathy, and multiorgan failure within a short period of time. Established specific therapy regimens and the introduction of liver transplantation (LTx) improves the prognosis for some etiologies. However, the overall mortality rate remains high (Bernal 2010). ALF accounts for approximately six to eight percent of LTx procedures in the US and Europe (Lee 2008). The accurate and timely diagnosis of ALF, rapid identification of the underlying cause, transfer of the patient to a specialised transplant center and, if applicable, initiation of a specific therapy and evaluation for LTx are crucial for modern ALF management. Therefore, we focus here on epidemiology, pathophysiology, diagnosis and treatment of ALF, including a brief overview of different etiologies and specific treatment options as well as novel tools to predict prognosis.

### Epidemiology and etiologies

ALF is a rare disease based on multiple causes and varying clinical courses, and exact epidemiologic data is scarce. The overall incidence of ALF is assumed as one to six cases per million people each year (Bernal 2010). Recent data from the US (Ostapowicz 2002), the UK (Bernal 2004), Sweden (Wei 2007), and Germany (Canbay 2009) reveal drug toxicity as the main cause of ALF, followed by viral hepatitis followed by unknown etiology. In contrast, in the Mediterranean, Asia, and

Africa, viral hepatitis is the main cause of ALF (Escorsell 2007, Koskinas 2008, Mudawi 2007, Oketani 2011).

**Table 1. Etiologies of ALF.**

Intoxication	Direct, idiosyncratic, paracetamol, ecstasy, amanita, phenprocoumon, tetracycline, halothane, isoniazid, anabolic drugs
Viral hepatitis	HBV, HAV, HEV, HBV+HDV, CMV, EBV, HSV
Immunological	Autoimmune, GVHD
Metabolic	Wilson's disease, alpha 1 antitrypsin deficiency, hemacromatosis
Vascular	Budd-Chiari syndrome, ischemic, venoocclusive disease
Pregnancy-induced	HELLP syndrome

## Intoxication

### Drug-induced liver injury

Drug toxicity is the main cause of ALF in Western societies. Although the incidence of drug-induced liver injury (DILI) in the general population was estimated at 1-2 cases per 100,000 person years (de Abajo 2004), in Germany DILI accounts for approximately 40% of patients with ALF (Canbay 2009). As a structured medical history may be difficult in some cases, a standardised clinical management to identify the cause of DILI and optimize specific treatment has been proposed (Fontana 2010). This includes assessment of clinical and laboratory features, determining the type of liver injury (hepatocellular vs. cholestatic), the clinical course after cessation of the suspected drug, assessment of risk factors (age, sex, alcohol consumption, obesity), exclusion of underlying liver diseases, previous episodes of DILI, liver biopsy and in some cases rechallenge to identify the drug. Furthermore, to identify a cause, one must distinguish between a direct (intrinsic; dose-dependent) and an idiosyncratic (immune-mediated hypersensitivity or metabolic injury) type of liver injury (Larson 2010). Acetaminophen intoxication, as discussed in detail below, is the prototype of a direct, dose-dependant intoxication with acute hepatocellular necrosis. However, most cases of DILI are due to idiosyncratic reactions with a latency period of up to one year after initiation of treatment. Drugs that induce idiosyncratic DILI include narcotics (halothane), antibiotics (amoxicilline/clavulanate; macrolides, nitrofurantoin, isoniazid), antihypertensive drugs (methyldopa) and anticonvulsants and antipsychotic drugs (valproic acid, chlorpromazine) and many others, including herbal medicine. Demonstrating the need for new algorithms and biomarkers of liver injury, the observation by Hy Zimmerman, that elevation of transaminase levels above three times the upper limit of normal indicates early DILI, is still in use to assess the risk of DILI in drugs in development since the 1970s (Reuben 2004).

### Acetaminophen intoxication

In a recent study, more than seventy percent of the patients with acetaminophen-induced ALF were reported as suicidal intents, the rest as accidents (Canbay 2009). The presence of any ALF risk in the recommended dose range of acetaminophen is controversial. However, the presence of risk factors, particularly obesity and alcohol abuse seem to increase the risk of ALF in patients that use acetaminophen (Canbay 2005, Krahenbuhl 2007). Acetaminophen serum concentrations above 300 µg/mL four hours after the ingestion is a predictor for severe hepatic necrosis. With high

doses of acetaminophen its metabolite *N*-acetyl-*p*-benzoquinone imine (NAPQI) accumulates in hepatocytes and induces hepatocellular necrosis. In the presence of glutathione, NAPQI is rapidly metabolized to non-toxic products and excreted via the bile (Bessems 2001). In acetaminophen intoxication, the glutathione pool is rapidly diminished, but could easily be restored by *N*-acetylcysteine therapy (see below).

**Table 2. Clinical determination of the cause of ALF.**

Etiology	Subtype	Investigation
Intoxication	Drug	Drug concentrations in serum
	Amanita	History
	Idiosyncratic drug toxicity	Drug concentrations in serum/ eosinophil count
Viral hepatitis	HAV	IgM HAV
	HBV	HBsAg, IgM anti-core, HBV DNA
	HBV/HDV	IHBsAg, gM HDV, HDV RNA
	HCV	Anti-HCV, HCV RNA
	HEV	Anti-HEV
Immunological	Autoimmune	ANA, LKM, SLA, ASMA, IgG
	GVHD	Biopsy
Metabolic	Wilson's disease	Urinary copper, ceruloplasmin in serum, slit-lamp examination
	AT deficiency	AT level in serum, AT genotyping
	Hemacromatosis	Ferritin in serum, transferrin saturation
Vascular	Budd-Chiari syndrome	Ultrasound (Doppler)
	Ischemic	Ultrasound (Doppler), echocardiography (ECO)
	Veno-occlusive disease	Ultrasound (Doppler)
Pregnancy-induced	HELLP syndrome	Hematocrit test, peripheral blood smear, platelet count

N/A, not available; ANA, anti-nuclear antibody; ASMA, anti-smooth muscle antibody; IgM, immunoglobulin M; IgG, immunoglobulin G; HBsAg, hepatitis B surface antigen.

## Amanita intoxication

The spectrum of mushroom poisoning varies from acute gastroenteritis to ALF. Even though the mortality rate of all mushroom poisoning cases is low, the mortality rate of those patients who develop ALF is extremely high, despite the improvement in intensive care management (Broussard 2001). *Amanita phalloides*, the wild mushroom, is attributed to the deadly mushroom poisoning, which occurs mostly in spring and early summer. Amanita toxin has a dose-dependant, direct hepatotoxic effect and disrupts hepatocyte mRNA synthesis (Kaufmann 2007).



## **Viral hepatitis**

Historically the most common cause of ALF in Europe and nowadays still the most prevalent etiologies in developing countries is fulminant viral hepatitis (Larson 2010). Hepatitis A and E (HAV and HEV), both transmitted via the fecal-oral route are endemic in countries with poor sanitation, tropical and subtropical countries. HEV was determined as the main cause of ALF in some Asian countries. The clinical presentation of HAV is more severe in adults than in children, and HEV is more common in pregnant women, especially in the third trimester (Dalton 2008). Fulminant HBV, transmitted vertically or by infected blood and body fluids is the most predominant viral cause of ALF in Western countries (Bernal 2010, Canbay 2009). The incidence of fulminant HBV is decreasing with the implementation of routine vaccination. Super-infection with hepatitis D virus in HBV infection is associated with higher risk to develop ALF. HBV infection and treatment is discussed in detail elsewhere. Acute cytomegalovirus, Epstein-Barr virus, parvovirus B19, and herpes simplex virus type 1 and 2 are less frequently associated with ALF.

## **Immunologic etiologies**

### **Autoimmune hepatitis**

In rare cases autoimmune hepatitis (AIH) may induce ALF. The acute onset of ALF and its potentially rapid progression causes a diagnostic dilemma since exclusion of other liver diseases might be too time-consuming in patients with ALF secondary to AIH. Thus, IgG elevation and positive ANA titer, combined with typical histological features might be sufficient to induce specific therapy in this cohort (Suzuki 2011). However, as DILI might perfectly mimic AIH, detailed history taking is the key to adequate therapy in all ALF patients with features of AIH (Bjornsson 2010).

### **Graft versus host disease**

With the development of new options of donor leukocyte infusion, non-myeloablative methods and umbilical cord blood transplantation, the indications of allogenic hematopoietic stem cell transplantation have been expanding in recent years (Ferrara 2009). Therefore, any hepatopathy in patients who have undergone bone marrow transplant is suspicious for Graft versus Host Disease (GVHD). On the other hand, chemotherapy and myeloablation themselves are hepatotoxic and might induce reactivation of HBV infection, leading to fulminant liver failure.

## **Wilson's Disease**

Wilson's Disease (WD), the autosomal recessive disorder of copper metabolism, is a rare cause of ALF. The prognosis of WD patients presenting with ALF is devastating, and almost all die without LTx (Lee 2008). Very high serum bilirubin and low alkaline phosphatase are typical laboratory constellations, and renal failure is a common clinical feature in WD.

## **Vascular disorders**

Acute systemic hypotension secondary to heart failure or systemic shock syndromes may induce acute liver injury (Canbay 2009). Occlusion of at least two liver veins in Budd-Chiari syndrome or venoocclusive disease is a rare cause of ALF. Anticoagulatory or lysis therapy is the management of choice; in severe cases,

emergency TIPSS or surgical shunt placement may be indicated, as well as a thorough workup to identify any underlying prothrombotic conditions (Fox 2011).

## **Pregnancy-induced liver injury**

Besides acute fatty liver of pregnancy (AFLP), which usually occurs in the third trimester of pregnancy, HELLP syndrome (hemolysis, elevated liver enzymes, low platelet level) is a rare complication of pregnancy and presents with ALF. HELLP syndrome typically presents with LDH, ALT and bilirubin elevation and thrombocytopenia. Hepatopathy usually completely reverses after termination of pregnancy. Patients are at increased risk for complications in future pregnancies (Hay 2008, Westbrook 2010).

## **Undetermined**

Despite dramatic improvements in diagnostic tests in approximately twenty percent of patients with ALF, the etiology remains undetermined (Canbay 2009, Hadem 2008).

## **Molecular mechanisms and clinical presentation**

As mentioned above, ALF occurs on the basis of acute hepatocellular injury caused by toxic, viral or metabolic stress or hypotension. However, regardless of the initial type of liver injury, ALF propels a series of events inducing hepatocellular necrosis and apoptosis and reducing the regeneration capacity of the liver. Massive loss of hepatocytes reduces the functional capacity of the liver for glucose, lipid and protein metabolism, biotransformation, synthesis of coagulation factors, leading to encephalopathy, coagulopathy, hypoglycemia, infections, renal and multi-organ failure. In fact, even the pattern of hepatic cell death might be of clinical importance, as necrosis or apoptosis seem to be specific for different causes and are associated with clinical outcome (Bechmann 2008, Volkmann 2008).

Apoptosis, programmed cell death, is a process in which ATP-dependant processes lead to activation of caspases that induce a cascade of events, which ends in the breakdown of the nucleus into chromatin bodies, interruption of membrane integrity and finally total breakdown of the cell into small vesicles, called apoptotic bodies. Upon massive cell injury, ATP depletion leads to necrosis with typical swelling of the cytoplasm, disruption of the cell membrane, imbalance of electrolyte homeostasis and karyolysis. Necrosis typically leads to local inflammation, induction of cytokine expression and migration of inflammatory cells. However, apoptosis itself might induce mechanisms that lead to necrosis and the ratio of apoptosis *vs.* necrosis seems to play an important role in liver injury rather than the individual events (Canbay 2004). This hypothesis is supported by observations that a death receptor agonist triggers massive necrosis secondary to the induction of apoptosis (Rodriguez 1996).

The rates of apoptosis or necrosis in ongoing ALF processes seem to be different according to the underlying etiologies (Bechmann 2010). The degree of apoptosis and necrosis, assessed by specific ELISA assays were significantly increased in amanita intoxication compared to other causes. Apoptosis is the predominant type of cell death in HBV and amanita-related ALF, *vs.* necrosis in acetaminophen and congestive heart failure. Furthermore, entecavir treatment of fulminant HBV

significantly reduces serum cell death markers and improves clinical outcome (Jochum 2009).

The regenerative capacity of the liver depends on the patient's gender, age, weight and previous history of liver diseases. Important mediators of liver regeneration include cytokines, growth factors and metabolic pathways for energy supply. In the adult liver, most hepatocytes are in the G<sub>0</sub>-phase of the cell cycle and non-proliferating. Upon stimulation with the proinflammatory cytokines tumour necrosis factor  $\alpha$  (TNF $\alpha$ ) and interleukin- (IL-) 6, growth factors like transforming-growth factor  $\alpha$  (TGF $\alpha$ ), epidermal growth factor (EGF) and hepatocyte growth factor (HGF) are able to induce hepatocyte proliferation. TNF and IL-6 also induce downstream pathways related to NF $\kappa$ B and STAT3 signaling. Both transcription factors are mandatory for coordination of the inflammatory response to liver injury and hepatocyte proliferation (Dierssen 2008). Emerging data supports an important role for hepatic progenitor and oval cells as well as vascular endothelial growth factor (VEGF) mediated angiogenesis in liver regeneration (Ding 2010, Dolle 2010).

TNF $\alpha$ , IL-1 and IL-6 are also important mediators of hyperdynamic circulation by alterations of nitric oxide synthesis in ALF (Larson 2010). Renal failure, hepatic encephalopathy, and brain edema are the results of these pathophysiologic changes. Hyperammonemia correlates with brain edema and survival (Clemmesen 1999). Decreased hepatic urea synthesis, renal insufficiency, the catabolic state of the musculoskeletal system and impaired blood-brain barrier leads to ammonia accumulation and alterations in local perfusion, which induces brain edema in ALF. Interestingly, brain edema is a presentation of ALF rather than cirrhosis, and the risk of brain edema increases with the grade of hepatic encephalopathy. After acute and massive hepatic cell death, the release of proinflammatory cytokines and intracellular material result in low systemic blood pressure leading to impairment of splanchnic circulation. Indeed, renal failure in ALF patients is common, up to 70% (Larsen 2011). Reduced qualitative and quantitative functions of platelets and inadequate synthesis of prothrombotic factors are the causes of coagulopathy. Leukopenia and impaired synthesis of complement factors in ALF patients increases the risk for infections, which might result in sepsis. Infections increase the duration of ICU stays and the mortality rate in ALF dramatically. With the impairment of hepatic gluconeogenesis, hypoglycemia is a frequent feature of patients with ALF (Canbay 2011).

**Table 3. Grade of hepatic encephalopathy (West Haven criteria).**

Grade	Clinical findings	Asterixes	EEG
I	Changes in behavior, euphoria, depression, mild confusion	+/-	Triphasic waves
II	Inappropriate behavior, lethargy, moderate confusion	+	Triphasic waves
III	Marked confusion, somnolence	+	Triphasic waves
IV	Coma	-	Delta waves

## Prognosis

With persistently high, although variable, mortality rates from ten to ninety percent, accurate prediction of the clinical course is crucial for accurate management and decision-making. Most importantly, identification of the underlying etiology improves prognosis and opens the door for specific treatment. The degree of hepatic encephalopathy is traditionally considered an important indicator of prognosis (O'Grady 1989). Cerebral edema and renal failure worsen the prognosis dramatically. In some studies, the INR was determined as a strongest single parameter to predict the prognosis of ALF. Another interesting point is that the presence of hepatic encephalopathy means a poor prognosis for acetaminophen induced ALF, which in contrast has little meaning for mushroom poisoning. LTx is the ultimate treatment option in patients with ALF, in which conservative treatment options fail and a lethal outcome is imminent. Therefore, assessment of likelihood of the individual patient to undergo a fatal course is important for timely listing of the patient. Standardised prognosis scores, based on reproducible criteria are important in times of donor organ shortage and to avoid LTx in patients that might fully recover without LTx (Canbay 2011).

King's college criteria (KCC) was established in the 1990s based on findings from a cohort of 588 patients with ALF (O'Grady 1989). The authors also introduced a classification based on the onset of encephalopathy after an initial rise in bilirubin levels into hyperacute (<7 days), acute (8-28 days) and sub-acute (5-12 weeks) liver failure (O'Grady 1993). KCC includes assessment of encephalopathy, coagulopathy (INR), acid homeostasis (pH), bilirubin and age. For patients with acetaminophen-induced ALF, another KCC formula was implied from that in patients with non-acetaminophen-induced liver injury. Clichy criteria were introduced for patients with fulminant HBV infection and include the degree of encephalopathy and factor V fraction as a measure for hepatic synthesis (Bernuau 1986). The model for end stage liver disease (MELD) was designed to predict the likelihood of survival after transjugular portacaval shunt (TIPS) in cirrhotic patients. However, it has recently been established as an allocation tool for LTx in patients with cirrhosis in the US and Europe. It has been tested as a model for prediction of ALF and was found to be superior to KCC and Clichy criteria in independent studies (Schmidt 2007, Yantorno 2007). Novel approaches that include mechanistic characteristics of ALF like the CK-18 modified MELD, which includes novel markers for hepatocellular death or lactate are promising, but need validation in prospective cohorts (Bechmann 2010, Hadem 2008).

**Table 4. Scoring systems in patients with ALF for emergent LTx.**

Scoring System		Prognostic factors
King's College Criteria	Paracetamol intoxication	Arterial pH <7.3 or INR >6.5 and creatinine >300 µmol/L and hepatic encephalopathy grade 3-4
	Non-paracetamol	INR >6.5 and hepatic encephalopathy or any of these three: INR >3.5 and bilirubin >300 µmol/L and age >40 years and unfavorable etiology (undetermined or drug-induced)
Clichy Criteria	HBV	Hepatic encephalopathy grade 3-4 and factor V <20% (for <30 years old); <30% (for >30 years old)
MELD		$10 \times (0.957^{\ln \text{serum creatinine}} + 0.378 \times \ln \text{total bilirubin} + 1.12 \times \ln \text{INR} + 0.643)$
CK-18 modified MELD		$10 \times (0.957^{\ln \text{serum creatinine}} + 0.378 \times \ln \text{CK18/M65} + 1.12 \times \ln \text{INR} + 0.643)$
Bilirubin-Lactate-Etiology Score (BILE score)		Bilirubin (µmol/l)/ 100+ Lactate (mmol/L) +4 (for cryptogenic ALF, Budd-Chiari or Phenprocoumon induced) -2 (for acetaminophen-induced) +0 (for other causes)

Adapted from Canbay 2011; INR, International Normalized Ratio; MELD, model of end stage liver disease.

## Treatment

### General management

Given the high risk of deterioration and development of hepatic coma, immediate transfer of the patient presenting with ALF to the ICU is mandatory. Early referral or at least consultation of an experienced transplant center is indicated in any ALF patient, since LTx is the ultimate treatment for ALF in case conservative therapy fails. The cause of ALF should be determined as soon as possible. Besides specific detailed history taking, laboratory and radiologic tests need to be done in order to establish the diagnosis of ALF and identify the underlying cause. Diagnostic studies include, but are not limited to, arterial blood gas analysis, glucose, electrolytes, bilirubin, ammoniac, lactate, protein, albumin, C-reactive protein (CRP), procalcitonin (PCT), urine electrolytes, urinalysis, and chest X-ray, cranial computed tomography (CT) in patients with advanced hepatic encephalopathy as well as assessment of intracranial pressure (ICP) in some cases. Additional to specific diagnostic studies (HBV serology, ceruloplasmin, urine copper concentration, etc.) transjugular or laparoscopic liver biopsy might be indicated to identify the underlying disease (Canbay 2011).

### Hepatic encephalopathy

In general in patients with hepatic encephalopathy, sedative agents should be avoided and if necessary restricted to short-acting benzodiazepines or propofol, as it might decrease intracranial pressure (Wijdicks 2002). Some studies favor utilization of ICP monitoring, especially in patients with hepatic encephalopathy grade III/IV,

and clinical signs of brain edema. Mannitol therapy (0.5-1 g/kg) might be beneficial in some patients. Head elevation, induction of hypothermia and hyperventilation are recommended by some experts in patients with increased ICP. With worsening of brain edema, the patients present with systemic hypertension and bradycardia (Cushing reflex), dilated and fixed pupils, and in the end respiratory arrest. The target ICP should remain below 20 mmHg, with cerebral perfusion pressure above 70 mmHg and jugular venous saturation of 55-80%. Phenytoin is the drug of choice for treatment of seizures and hypertonic sodium chloride might be beneficial on ICP (Larsen 2011). Symptomatic treatment of encephalopathy includes bowel decontamination with neomycin or rifaximin, induction of diarrhea and reduction of colonic pH and thus reduction of ammonia absorption by lactulose as well as treatment with branched-chain aminoacids to improve peripheral ammonia metabolism, although large, randomized clinical trials have failed to show clinical improvement (Larson 2010, Nguyen 2011).

## **Coagulopathy**

In general, without clinical signs of bleeding, fresh frozen plasma (FFP) or individual coagulation factor treatment is not indicated. To exclude vitamin K deficiency, vitamin K challenge should be performed. Platelets and recombinant activated factor VII are indicated in case of bleeding or before invasive procedures.

## **Liver Transplantation**

LTx, is the therapy of choice for ALF in those individuals with insufficient regeneration capacity and an otherwise fatal prognosis. In patients without contraindications to LTx, the one-year survival rate is as high as 80-90% with a five-year survival of 55%. As mentioned above, with LTx available as the most favorable therapy, the accurate assessment of the patient's prognosis is crucial to initiate evaluation of the patient for LTx and decision making in this clinical setting. The underlying disease, the clinical condition and the status of the graft influence the patient's prognosis after the transplant. In times of general organ shortage, the graft pool might be extended by utilisation of living-donor transplants, split liver surgery or transplantation of livers in reduced conditions (Canbay 2011).

## **Extracorporeal liver support systems**

Extracorporeal systems include support devices or bioreactors, which provide individual or a combination of functions that are insufficiently performed by the diseased liver. The scientific and clinical aim of the introduction of these novel techniques is to stabilize the patient until a donor organ is available or ideally until the liver completely recovers. However, adequately powered, randomized studies to establish these techniques in the treatment of ALF are either lacking or have failed to show any benefit over conventional therapy. Thus, treatment with these devices most likely remains a part of a bridging to transplantation strategy within an academic setting. The same accounts for novel stem cell and adult hepatocyte transplant approaches (Canbay 2011).

## Specific treatment options

**Table 5. Specific treatments for the causes of ALF.**

Causes	Medication	Doses
Acetaminophen	Activated oral charcoal	1 g/kg
	N-acetyl cysteine (oral/IV)	150 mg/kg loading dose, 50 mg/kg for 4h, 100 mg/kg for 20h
Mushroom	Silibin	20-50 mg/kg/day
Acute HBV	Lamivudine	100-300 mg/day
	Entecavir	0.5-1 mg/day
	Tenofovir	245 mg/day
Pregnancy	Delivery	
Autoimmune	Prednisolone	1-2 mg/kg/day
Budd-Chiari syndrome	TIPS/surgical shunt	
HSV	Acyclovir	3x10 mg/kg/day

### Acetaminophen Poisoning

Activated oral charcoal (1 g/kg) might be indicated if administered up to four hours after acetaminophen ingestion. N-acetyl cysteine infusion to restore glutathione should be administered until as late as 24-36 hours after ingestion, and continued for 20 hours or longer. Monitoring of blood acetaminophen levels might help in decision-making regarding the duration or initiation of treatment. N-acetyl cysteine should be started as soon as possible, even in patients with a low probability of acetaminophen overdose or even in patients with non-paracetamol drug-induced ALF (Lee 2009). Moreover, steroid and ursodeoxycholic acid combination seems to be effective in drug-induced severe liver injury (Wree 2011).

### Mushroom poisoning

Silibin, with its cytoprotective effects against amatoxin is used despite a lack of the controlled trials (Broussard 2001).

### Acute HBV infection

Antiviral therapy with lamivudine or entecavir has proven as efficient and safe in fulminant HBV infection (Tillmann 2006). Moreover, with initiation of entecavir within the first days of admission, HBsAg concentrations and cell death were significantly reduced (Jochum 2009).

### Pregnancy related

Immediate delivery and abortion are the available causal treatments. With early delivery, the rates of fetal death remain high, however the mortality rate of the mother decreases significantly (Westbrook 2010).

### Autoimmune hepatitis

Steroid treatment should be initiated and if started in time might help to avoid the need for LTx. With improvement of liver function, prednisone might be tapered and azathioprine treatment added to the regimens. Recent studies identified the topical

steroid budesonide as a potential substitute for systemic prednisone therapy (Schramm 2010).

## References

- Bechmann LP, Jochum C, Kocabayoglu P, et al. Cytokeratin 18-based modification of the MELD score improves prediction of spontaneous survival after acute liver injury. *J Hepatol* 2010;53:639-47. ([Abstract](#))
- Bechmann LP, Marquitan G, Jochum C, Saner F, Gerken G, Canbay A. Apoptosis versus necrosis rate as a predictor in acute liver failure following acetaminophen intoxication compared with acute-on-chronic liver failure. *Liver Int* 2008;28:713-6. ([Abstract](#))
- Bernal W, Auzinger G, Dhawan A, Wendon J. Acute liver failure. *Lancet* 2010;376:190-201. ([Abstract](#))
- Bernal W, Wendon J. Liver transplantation in adults with acute liver failure. *J Hepatol* 2004;40:192-7. ([Abstract](#))
- Bernuau J, Goudeau A, Poinard T, et al. Multivariate analysis of prognostic factors in fulminant hepatitis B. *Hepatology* 1986;6:648-51. ([Abstract](#))
- Bessems JG, Vermeulen NP. Paracetamol (acetaminophen)-induced toxicity: molecular and biochemical mechanisms, analogues and protective approaches. *Crit Rev Toxicol* 2001;31:55-138. ([Abstract](#))
- Bjornsson E, Talwalkar J, Treeprasertsuk S, et al. Drug-induced autoimmune hepatitis: clinical characteristics and prognosis. *Hepatology* 2010;51:2040-8. ([Abstract](#))
- Broussard CN, Aggarwal A, Lacey SR, et al. Mushroom poisoning--from diarrhea to liver transplantation. *Am J Gastroenterol* 2001;96:3195-8. ([Abstract](#))
- Canbay A, Tacke F, Hadem J, Trautwein C, Gerken G, Manns MP. Acute Liver Failure - a Life-Threatening Disease. *Dtsch Arztebl International* 2011;108:714-20. ([Abstract](#))
- Canbay A, Jochum C, Bechmann LP, et al. Acute liver failure in a metropolitan area in Germany: a retrospective study (2002 - 2008). *Z Gastroenterol* 2009;47:807-13. ([Abstract](#))
- Canbay A, Chen S-Y, Gieseler RK, et al. Overweight patients are more susceptible for acute liver failure. *Hepatogastroenterology* 2005; 52:1516-20. ([Abstract](#))
- Canbay A, Friedman S, Gores GJ. Apoptosis: the nexus of liver injury and fibrosis. *Hepatology* 2004;39:273-8. ([Abstract](#))
- Clemmesen JO, Larsen FS, Kondrup J, Hansen BA, Ott P. Cerebral herniation in patients with acute liver failure is correlated with arterial ammonia concentration. *Hepatology* 1999;29:648-53. ([Abstract](#))
- Dalton HR, Bendall R, Ijaz S, Banks M. Hepatitis E: an emerging infection in developed countries. *Lancet Infect Dis* 2008;8:698-709. ([Abstract](#))
- de Abajo FJ, Montero D, Madurga M, Garcia Rodriguez LA. Acute and clinically relevant drug-induced liver injury: a population based case-control study. *Br J Clin Pharmacol* 2004;58:71-80. ([Abstract](#))
- Dierssen U, Beraza N, Lutz HH, et al. Molecular dissection of gp130-dependent pathways in hepatocytes during liver regeneration. *J Biol Chem* 2008;283:9886-95. ([Abstract](#))
- Ding BS, Nolan DJ, Butler JM, et al. Inductive angiocrine signals from sinusoidal endothelium are required for liver regeneration. *Nature* 2010;468:310-5. ([Abstract](#))
- Dolle L, Best J, Mei J, et al. The quest for liver progenitor cells: a practical point of view. *J Hepatol* 2010;52:117-29. ([Abstract](#))
- Escorsell A, Mas A, de la Mata M. Acute liver failure in Spain: analysis of 267 cases. *Liver Transpl* 2007;13:1389-95. ([Abstract](#))
- Ferrara JL, Levine JE, Reddy P, Holler E. Graft-versus-host disease. *Lancet* 2009;373:1550-61. ([Abstract](#))
- Fontana RJ, Seeff LB, Andrade RJ, et al. Standardization of nomenclature and causality assessment in drug-induced liver injury: summary of a clinical research workshop. *Hepatology* 2010;52:730-42. ([Abstract](#))
- Fox MA, Fox JA, Davies MH. Budd-Chiari syndrome--a review of the diagnosis and management. *Acute Med* 2011;10:5-9. ([Abstract](#))
- Hadem J, Stiefel P, Bahr MJ, et al. Prognostic implications of lactate, bilirubin, and etiology in German patients with acute liver failure. *Clin Gastroenterol Hepatol* 2008;6:339-45. ([Abstract](#))



- Hay JE. Liver disease in pregnancy. *Hepatology* 2008;47:1067-76. ([Abstract](#))
- Jochum C, Gieseler RK, Gawlista I, et al. Hepatitis B-associated acute liver failure: immediate treatment with entecavir inhibits hepatitis B virus replication and potentially its sequelae. *Digestion* 2009;80:235-40. ([Abstract](#))
- Kaufmann P. [Mushroom poisonings: syndromic diagnosis and treatment]. *Wien Med Wochenschr* 2007;157:493-502. ([Abstract](#))
- Koskinas J, Deutsch M, Kountouras D, et al. Aetiology and outcome of acute hepatic failure in Greece: experience of two academic hospital centres. *Liver Int* 2008; 28:821-7. ([Abstract](#))
- Krahenbuhl S, Brauchli Y, Kummer O, et al. Acute liver failure in two patients with regular alcohol consumption ingesting paracetamol at therapeutic dosage. *Digestion* 2007;75:232-7. ([Abstract](#))
- Larsen FS, Bjerring PN. Acute liver failure. *Curr Opin Crit Care* 2011;17:160-4. ([Abstract](#))
- Larson AM. Diagnosis and management of acute liver failure. *Curr Opin Gastroenterol* 2010;26:214-21. ([Abstract](#))
- Lee WM, Hynan LS, Rossaro L, et al. Intravenous N-acetylcysteine improves transplant-free survival in early stage non-acetaminophen acute liver failure. *Gastroenterology* 2009;137:856-64, 64 e1. ([Abstract](#))
- Lee WM. Etiologies of acute liver failure. *Semin Liver Dis* 2008;28:142-52. ([Abstract](#))
- Lee WM, Squires RH, Jr., Nyberg SL, Doo E, Hoofnagle JH. Acute liver failure: Summary of a workshop. *Hepatology* 2008;47:1401-15. ([Abstract](#))
- Mudawi HM, Yousif BA. Fulminant hepatic failure in an African setting: etiology, clinical course, and predictors of mortality. *Dig Dis Sci* 2007;52:3266-9. ([Abstract](#))
- Nguyen NT, Vierling JM. Acute liver failure. *Curr Opin Organ Transplant* 2011;16:289-96. ([Abstract](#))
- O'Grady JG. Acute liver failure. *Postgrad Med J* 2005;81:148-54. ([Abstract](#))
- O'Grady JG, Schalm SW, Williams R. Acute liver failure: redefining the syndromes. *Lancet* 1993;342:273-5. ([Abstract](#))
- O'Grady JG, Alexander GJ, Hayllar KM, Williams R. Early indicators of prognosis in fulminant hepatic failure. *Gastroenterology* 1989;97:439-45. ([Abstract](#))
- Oketani M, Ido A, Tsubouchi H. Changing etiologies and outcomes of acute liver failure: A perspective from Japan. *J Gastroenterol Hepatol* 2011;26 Suppl 1:65-71. ([Abstract](#))
- Ostapowicz G, Fontana RJ, Schiodt FV, et al. Results of a prospective study of acute liver failure at 17 tertiary care centers in the United States. *Ann Intern Med* 2002;137:947-54. ([Abstract](#))
- Reuben A. Hy's law. *Hepatology* 2004;39:574-8. ([Abstract](#))
- Rodriguez I, Matsuura K, Khatib K, Reed JC, Nagata S, Vassalli P. A bcl-2 transgene expressed in hepatocytes protects mice from fulminant liver destruction but not from rapid death induced by anti-Fas antibody injection. *J Exp Med* 1996;183:1031-6. ([Abstract](#))
- Schmidt LE, Larsen FS. MELD score as a predictor of liver failure and death in patients with acetaminophen-induced liver injury. *Hepatology* 2007;45:789-96. ([Abstract](#))
- Schramm C, Weiler-Normann C, Wiegand C, Hellweg S, Muller S, Lohse AW. Treatment response in patients with autoimmune hepatitis. *Hepatology* 2010;52:2247-8. ([Abstract](#))
- Suzuki A, Brunt EM, Kleiner DE, et al. The use of liver biopsy evaluation in discrimination of idiopathic autoimmune hepatitis versus drug-induced liver injury. *Hepatology* 2011. ([Abstract](#))
- Tillmann HL, Hadem J, Leifeld L, et al. Safety and efficacy of lamivudine in patients with severe acute or fulminant hepatitis B, a multicenter experience. *J Viral Hepat* 2006;13:256-63. ([Abstract](#))
- Volkman X, Anstaett M, Hadem J, et al. Caspase activation is associated with spontaneous recovery from acute liver failure. *Hepatology* 2008;47:1624-33. ([Abstract](#))
- Wei G, Bergquist A, Broome U, et al. Acute liver failure in Sweden: etiology and outcome. *J Intern Med* 2007;262:393-401. ([Abstract](#))
- Westbrook RH, Yeoman AD, Joshi D, et al. Outcomes of severe pregnancy-related liver disease: refining the role of transplantation. *Am J Transplant* 2010;10:2520-6. ([Abstract](#))
- Wijdicks EF, Nyberg SL. Propofol to control intracranial pressure in fulminant hepatic failure. *Transplant Proc* 2002;34:1220-2. ([Abstract](#))

## 538 Hepatology 2012

- Wree A, Dechene A, Herzer K, et al. Steroid and ursodesoxycholic Acid combination therapy in severe drug-induced liver injury. *Digestion* 2011;84:54-9. ([Abstract](#))
- Yantorno SE, Kremers WK, Ruf AE, Trentadue JJ, Podesta LG, Villamil FG. MELD is superior to King's college and Clichy's criteria to assess prognosis in fulminant hepatic failure. *Liver Transpl* 2007;13:822-8. ([Abstract](#))





## Index

**A**

Abacavir 308  
 Abbott RealTime 192  
 Abstinence 495  
 ABT-072 240  
 ABT-333 240  
 ABT-450 240  
 Acetaminophen 535  
 Acetaminophen intoxication 527  
 ACH-1625 240  
 Acute hepatitis  
   hepatitis B 36  
   hepatitis C 47  
   hepatitis C treatment 226  
   hepatitis E 59  
 Acute Liver Failure 526  
 Adefovir 137, 138, 142, 164, 295, 297,  
   323  
 Adherence 220, 269  
 ADV 138  
 Adverse drug reactions *see* Side effects  
 Albinterferon 256  
 Alcoholic Hepatitis 488  
 Alisporivir 240  
 Amanita intoxication 528  
 Aminotransferase levels 227  
 Amplicor 192  
 ANA598 240  
 Antidepressants 266  
 Anti-TNF  $\alpha$  antibodies 465  
 Anti-TNF- $\alpha$  therapy 497  
 Antiviral resistance 206  
 ARFP 92  
 Arterial chemoembolisation 343  
 Arthralgia 262  
 Arthropathy 417  
 Asthenia 263  
 Asunaprevir 239  
 Autoimmune hemolytic anemia 273, 281  
 Autoimmune hepatitis 453, 529  
 Autoimmune thyroidopathies 273  
 Azathioprin 471  
 Azathioprine 458

**B**

Baraclude 137  
 BI201335 239  
 BI207127 240  
 BILB 1941 240  
 Biochemical response 136  
 Blood transfusion 45  
   hepatitis B virus 34  
 BMS-650032 239  
 BMS-790052 240, 251  
 BMS-824393 240, 251  
 Boceprevir 205, 208, 239, 244, 253, 308  
   adverse effects 268  
 Breakthrough 204  
 Budd-Chiari syndrome 522  
 Budesonide 462

**C**

Cardiac arrhythmias 416  
 Cardiomyopathy 273, 416  
 Celgosivir 240  
 Ceruloplasmin 440  
 cEVR 204  
 Cholestyramine 470  
 Chronic hepatitis  
   hepatitis B 37  
   hepatitis C 48  
   Hepatitis D 174  
 Ciluprevir 239, 243  
 Cirrhosis  
   HBV/HCV coinfection 322  
   hepatitis C 49  
 Cirrhosis complications  
   end-stage liver disease 389  
 Clevudine 181  
 Cobas Amplicor HCV 193  
 Cobas Ampliprep 192  
 Cognitive disturbances 262  
 Coinfection  
   HBV/HCV 318  
 Coinfections 230  
 Colchicine 471  
 Competitive PCR 193  
 Complete Early Virological Response 204  
 Consensus Interferon 205

Copegus 205  
 Copper 441  
 Corticosteroids 495  
 Cryoglobulinemic vasculitis 273  
 Cyclophilin B inhibitors 252  
 Cyclophosphamide 462, 464  
 Cyclosporin 462, 471  
 Cyclosporine 464

**D**

Daclatasvir 240  
 Danoprevir 239  
 Debio-025 240  
 Deferasirox 418  
 Deflazacort 463  
 Delirium 262  
 Delta hepatitis *see* Hepatitis D  
 Depressive episodes 262  
 Diabetes mellitus 273, 416  
 Dimercaprol 443  
 Direct sequence analysis 197  
 Disease progression  
   hepatitis C 50  
 Disorders of the hepatic artery 514  
 Disorders of the hepatic veins 522  
 Disorders of the portal vein 518  
 D-penicillamine 471  
 Drug abuse 230  
 Drug interactions 225  
 Drug-induced liver injury 527  
 Dyspnea 264

**E**

Early Virological Response 204  
 Efavirenz 308  
 Emtricitabine 164, 296, 308  
 End-stage liver disease  
   HIV infection 386  
 Entecavir 137, 138, 143, 161, 297, 323  
 Epidemiology  
   hepatitis A 27  
   hepatitis C 44  
   hepatitis D 176  
 eRVR 204  
 ESLD *see* End-stage liver disease  
 ETV 138  
 EVR 204  
 Extended Rapid Virological Response  
   204

Extracorporeal liver support systems 534  
 Extrahepatic manifestations  
   hepatitis A 29  
   hepatitis B 41  
   hepatitis C 49, 230  
   hepatitis E 61

**F**

Famcyclovir 181  
 Fatigue 262  
 Ferroportin Disease 420  
 Filibuvir 240  
 Flu-like symptoms 262

**G**

Gastrointestinal disorders 263  
 Genotypes  
   hepatitis C virus 86  
 GH-insufficiency 273  
 Glomerulonephritis 41, 282  
 Graft versus host disease 529  
 GS-5885 240, 251  
 GS-9190 240  
 GS-9451 240

**H**

HAART  
   liver transplantation 391  
 Haemochromatosis 405  
   juvenile hereditary 419  
   secondary 421  
   TFR2-related 419  
 Hair loss 267  
 Hashimoto thyroiditis 273  
 HBcAg 120  
 HBeAg 121  
 HBeAg loss 149  
 HBeAg seroconversion 133  
 HBsAg 120  
   treatment response 150  
 HBsAg loss 134  
 HBV 65  
   animal models 75  
   serological tests 119  
 HBV DNA  
   treatment response 147  
 HBV genotypes 122

- treatment response 147
  - HBV Virology 65
  - HBV/HCV Coinfection 318
  - HBV/HIV coinfection 291
  - HCC *see* Hepatocellular carcinoma
  - HCV *See also* Hepatitis C virus
  - HCV genotype 1 207
  - HCV genotypes 2 and 3 215
  - HCV genotypes 4, 5, and 6 218
  - HCV genotyping 196
  - HCV life cycle 240
  - HCV replicon systems 97
  - HCV SuperQuant 192
  - HCV/HBV Coinfection 318
  - HCV/HBV management
    - liver transplantation 390
  - HCV/HIV Coinfection 302
  - HCV-796 240
  - HCV-associated thrombocytopenia 281
  - HCVcc 98
  - HCVpp 98
  - HDV *see* Hepatitis D
  - Hemodialysis 230
    - transmission of HCV 47
  - Hemophilia 230
  - Hepadnaviridae 65
  - Hepatic fibrosis 326
  - Hepatitis A 27
    - prophylaxis 108
    - vaccination 110
  - Hepatitis B 32
    - chronic infection 124
    - coinfection with HCV 318
    - diagnostic tests 119
    - drug resistance 160
    - hepatitis C coinfection 40
    - hepatitis D coinfection 40
    - immunosuppression 154
    - liver biopsy 125
    - occult infection 125, 320
    - past infection 123
    - post-exposure prophylaxis 113
    - pregnancy 153
    - prognostic factors 147
    - prophylaxis 109
    - serum transaminases 124
    - superinfection 320
    - treatment 128
    - treatment guidelines 130
    - vaccination 111
  - Hepatitis C 44
    - coinfection with HBV 318
    - diagnostic Tests 189
    - endocrine manifestations 283
    - extrahepatic manifestations 272
    - lifecycle 93
    - prophylaxis 109
    - serologic assays 190
    - superinfection 319
    - treatment 202
    - vaccination 114
    - virology 85
  - Hepatitis D
    - diagnostic procedures 174
    - prophylaxis 109
    - treatment 174
    - virology 175
  - Hepatitis E 55
    - virology 55
  - Hepatocellular carcinoma 338, 398
    - curative therapy 341
    - HBV/HCV coinfection 322
    - palliative therapy 343
  - Hepatoportal sclerosis 521
  - Hepsera 137
  - Hereditary hemorrhagic teleangiectasia 516
  - HEV *See* Hepatitis E virus
  - Histologic response 136
  - HIV
    - hepatitis E 60
  - HIV/HCV Coinfection 302
  - HIV/HVB coinfection
    - end-stage liver disease 397
  - Horizontal transmission
    - hepatitis B virus 34
- I**
- Idiopathic pulmonary fibrosis 273
  - IDX184 240
  - IDX320 240
  - IDX375 240
  - IL28B 160
  - Immune thrombocytopenic purpura 273
  - Incivek 244
  - Incivo 244
  - Infergen 205
  - Injection drug use 45
  - Insulin resistance 273
  - Interferon lambda 1 256
  - Interferon  $\alpha$  182

Interferon  $\alpha$ -2a 137, 205  
 Interferon  $\alpha$ -2b 137, 205  
 Interferons 139  
 Intron 137, 205  
 Iron overload 405  
 Irritability 262

**L**

LAM 138  
 Lamivudine 137, 138, 142, 161, 296, 308  
 LdT 138  
 Lead-In 204  
 Lichen planus 273  
 Liver biopsy 327  
 Liver cancer  
   prophylaxis 345  
 Liver cirrhosis  
   compensated 228  
 Liver fibrosis  
   surrogate markers 329  
 Liver retransplantation  
   HIV infection 398  
 Liver transplantation 349  
   AIH 466  
   hepatitis delta 183  
   HIV infection 386  
   NASH 433  
   PSC 478

**M**

Malignant lymphoproliferative disorders  
   276  
 Membrano-proliferative  
   glomerulonephritis 273  
 Mercitabine 240, 248, 250  
 Methotrexate 471  
 Miravirsen 240  
 Mixed cryoglobulinemia 272  
   treatment 277  
 MK-3281 240  
 MK-5172 239  
 MK-7009 239  
 Molecular-targeted therapeutic  
   strategies 344  
 Monoclonal gammopathies 273  
 Mushroom poisoning 535  
 Myalgia 262  
 Mycophenolate mofetil 462  
 Mycophenolic acid 464

Myopathy 273

**N**

N-acetyl cysteine 497  
 NAFLD 427  
 Narlaprevir 239  
 NASH 427  
 Natural history  
   hepatitis B 36  
   hepatitis C 49  
 Needlestick injury  
   transmission of HCV 47  
 Nephropathy 41  
 Nexavar 344  
 NIM811 240  
 Nitazoxanide 240, 253  
 NM283 240  
 Nodular regenerative hyperplasia 521  
 Non-Hodgkin lymphomas 273  
 Nonresponse 204  
 Nosocomial infection  
   hepatitis B 35  
 NS2 91  
 NS3 91  
 NS3-4A protease inhibitors 241  
 NS4A 91  
 NS4B 91  
 NS5A 92  
 NS5A inhibitors 251  
 NS5B 92  
 NS5B polymerase inhibitors 248  
 Nucleic acid testing for HCV 191  
 Nucleos(t)ide analogs 138, 141  
 Nucleoside analogs  
   delta hepatitis 181  
 Null response 204

**O**

Opioid antagonists 470  
 Organ transplantation  
   HCV transmission 46  
   hepatitis B virus 36  
   hepatitis E virus 60  
 Orthotopic liver transplant 392  
   outcome 394  
 Osler-Weber-Rendu syndrome 516



**P**

p7 protein 91  
 Partial Response 204  
 Pathogenesis  
   hepatitis D 178  
 Pegasys 137, 205  
 PEG-IFN lambda 1 256  
 PEG-IFN maintenance therapy 215  
 PEG-Intron 205  
 Pegylated interferon alpha 182  
 Peliosis hepatis 513  
 Penicillamine 443, 444  
 Pentoxifylline 496  
 Perinatal transmission  
   hepatitis B virus 34  
   hepatitis C virus 46  
 Peripheral neuropathy 273, 275  
   treatment 278  
 PF-00868554 240  
 Phlebotomy 418  
 PHX1766 239  
 Polyarteritis nodosa 41  
 Porphyria cutanea tarda 273  
 Portal vein thrombosis 518  
 Postexposure prophylaxis  
   hepatitis B infection 36  
 PPI-461 240, 251  
 Prednisone 458  
 Pregnancy-induced liver injury 530  
 Primary biliary cirrhosis 467  
 Primary sclerosing cholangitis 473  
 Prognosis  
   hepatitis B 39  
 Prophylaxis  
   viral hepatitis 108  
 PSI-7977 250  
 PSI-938 240, 250  
 Psychosis 262

**Q**

Quadruple therapy 254  
 Qualitative assays for HCV RNA detection  
   192  
 Qualitative RT-PCR 192  
 Quantitative HCV RNA detection 193

**R**

R1626 240

R7128 240  
 R7227 239  
 Radiotherapy 344  
 Raltegravir 308  
 Rapamycin 462  
 Rapid Virological Response 204  
 RealTime HCV test 196  
 Real-time PCR technology 197  
 Real-time PCR-based HCV RNA detection  
   assays 194  
 Rebetalol 205  
 Recombinant interferon alpha  
   delta hepatitis 182  
 Relapse 204  
 Renal impairment 275  
 Reverse hybridising assay 197  
 Rheumatoid arthralgias 273  
 Rheumatoid factor positivity 273  
 ribavirin 306  
 Ribavirin 181, 205, 223, 322  
 Rifampicin 470  
 Roferon 137, 205  
 RVR 204

**S**

SCH503034 239  
 SCH900518 239  
 Sebivo 137  
 Serotonin antagonists 470  
 Serum HBV DNA assays 121  
 Sexual impotence 417  
 Sexual transmission  
   hepatitis B virus 33  
   hepatitis C virus 46  
 Sicca syndrome 273  
 Side effects 262  
   management 221  
 Simeprevir 239  
 Sinusoidal obstruction syndrome 509  
 Skin disorders 267  
 Sleep disturbances 262, 266  
 Sorafenib 344  
 Suicidal syndrome 262  
 Sulindac 472  
 Sustained Virological Response 204  
 SVR 204  
 SVR-12 204  
 Systemic vasculitis 275  
   treatment 278

**T**

Tacrolimus 462, 464  
 Taxonomy  
   hepatitis C virus 86  
 TDF 138  
 Telaprevir 205, 210, 239, 244, 253, 308  
   adverse effects 268  
 Telbivudine 137, 138, 143, 161, 297, 323  
 Tenofovir 137, 138, 144, 161, 296, 323  
 Tetrathiomolybdate 443, 444, 446  
 TMC435350 239  
 TMC647055 240  
 Transcription-mediated 192  
 Transferrin receptor 2 419  
 Transient elastography 330  
 Transmission  
   hepatitis A virus 27  
   hepatitis B virus 33  
   hepatitis C virus 45  
   hepatitis E virus 58  
 Transplantation 349  
 Treatment failure 212  
 Treatment response 206  
 Trientine 443, 445

**U**

Ulcerative colitis 478  
 Ursodeoxycholic acid 465, 470, 472, 477

**V**

Vaccination 108  
   hepatitis B 111  
   hepatitis C 114  
   hepatitis E 61, 115  
 Valopicitabine 240, 249  
 Vaniprevir 239  
 Vascular liver disease 509  
 VCH222 240  
 VCH759 240  
 VCH916 240  
 Versant 192, 194  
 Victrelis 244  
 Viread 137  
 Virologic response 136  
 Virology  
   HDV 175  
   hepatitis B 65  
   hepatitis C 85  
 Vitamin E 446

**W**

Weight loss 263  
 Wilson's Disease 437

**Z**

Zeffix 137  
 Zinc 445  
 Zinc acetate 444



goo.gl/m7lm8



FLYING PUBLISHER

# Hepatology *2012*

*A Clinical Textbook*

Mauss, Berg, Rockstroh, Sarrazin, Wedemeyer

Hepatology is a rapidly developing area of medicine. The exciting new oral treatments for HCV, breakthroughs in the treatment of chronic hepatitis B, and the identification of genes associated with metabolic liver diseases are just some highlights.

*Hepatology — A clinical textbook* is an up-to-date source of information for physicians, residents and advanced medical students seeking a broader understanding of liver disease.

[www.flyingpublisher.com](http://www.flyingpublisher.com)

ISBN 978-3-924774-73-8



9 783924 774738